



**HA12P**

*pluscom*<sup>+</sup>

## Operating instructions

Types:

HA12P/60-4

HA12P/75-4

HA12P/90-4

HA12P/110-4

D

GB

F

E

I

# Foreword

Dear Customer,

Bock compressors are top-quality, reliable, service-friendly quality products. Please comply with the following operating and maintenance instructions so that you can benefit from all advantages to the full and use your refrigerating system throughout its entire service life. If you have any questions about installation, operation and accessories, please contact our technical service or your refrigerating system wholesale dealer or our representative. The Bock service team is available by phone under +49 7022 9454-0, by e-mail under [mail@bock.de](mailto:mail@bock.de) or on the internet under [www.bock.de](http://www.bock.de). In addition, for German speaking countries we have set up a toll-free hotline under 00 800 / 800 000 88 from Monday to Saturday between 8 a.m. and 9 p.m. Any suggestions you may have regarding the on-going development of our compressor, equipment and parts programme are welcome at any time.

**Please read the information summarised for you in this manual before starting work.**

It contains important instructions for safety, installation, initial commissioning and handling. In addition you will find information on maintenance, spare parts and accessories.

Some instructions are identified by special symbols with the following meaning:



**WARNING!** This symbol is used to indicate that inaccurate compliance or total failure to comply with the instructions could cause injury to persons or damage to the compressor or refrigerating machine.



**DANGER!** This symbol refers to instructions for avoiding direct severe dangers to persons.



**DANGER!** This symbol refers to instruction for avoiding direct severe dangers to persons or plant by electrical current.



This symbol indicates important additional instructions which you should observe during your work.

The high quality standard of Bock compressors is guaranteed also by on-going further development of machine, features and accessories. This could possibly result in non-conformities between this present manual and your compressor. Please understand that it is not possible for any claims to be derived from the details, illustrations and descriptions.

Your team at  
Bock Kältemaschinen GmbH

**- Subject to modification -**

# Contents

	Page
<b>Safety instructions</b>	<b>4</b>
<b>Product description</b>	<b>5</b>
Use as intended	
Short description	
Main and functional parts	
Name plate	
Type code	
<b>Areas of Application</b>	<b>7</b>
Coolant	
Oil filling	
Limits of application diagrams	
<b>Installation</b>	<b>9</b>
Erection	
Pipe connections	
Pipes	
Shutoff valves	
<b>Electrical systems</b>	<b>12</b>
General instructions	
Connection of the driving motor	
Wiring diagram for direct start 230 V $\Delta$ / 400 V Y	
Electronic trigger MP 10	
Connection of the release unit MP 10	
Function test of the electronic trigger MP 10	
Information for contactor and motor contactor selection	
Fan motor	
<b>Start-up</b>	<b>16</b>
Preparations for start-up	
Pressure strength test	
Tightness test	
Evacuation	
Filling with coolant	
Start up	
Liquid sluggings	
Connection of the oil level controller	
<b>Maintenance</b>	<b>18</b>
Safety instructions	
Spare parts recommendation/Accessories	
Screwed unions	
Lubricants	
Decommissioning	
<b>Technical Specifications</b>	<b>20</b>
<b>Dimensions and connections</b>	<b>21</b>
<b>Conformity and manufacturer's declaration</b>	<b>22</b>

# Safety instructions



The Bock refrigerating compressors named in the title are intended for installation in machines (within the EU according to EU directive 98/37/EC Machinery Directive, 97/23/EC Pressure Equipment Directive and 73/23/EC Low Voltage Directive). Initial commissioning is only allowed when the compressor has been installed according to these instructions and the whole machine in which it is integrated has been tested and accepted according to the statutory regulations.

Bock refrigerating compressors have been designed to state-of-the-art engineering. Safety for the user is given particular priority during the design stage. However, it is always possible for the refrigerating machine and operation thereof to pose unavoidable residual risks. **This is why these instructions must be observed carefully by every person working at the compressor.**

Work on the compressor may only be carried out by persons whose technical training, skills and experience together with their knowledge of pertinent regulations and documentation means that they are capable of assessing the work to be carried out and detecting any possible dangers.



## Safety instructions

- Any handling of the compressor is permissible only by skilled personnel!
- Observe national safety regulations, accident prevention regulations, generally recognized technical rules as well as specific regulations (EN 378, EN 60204, EN 60335 etc.).
- Carry compressors only with hoists with sufficient lifting power.
- Operate compressors only in refrigeration plants with approved refrigerants.
- Do not exceed permissible operating pressure – even for testing purposes.
- Caution! Compressors are filled with protective gas ex works (approx. 3 bar nitrogen). Avoid possible injuries to skin and eyes! Wear goggles! Relieve pressure of compressors before connection to the refrigeration system!
- Before start-up check compressor for transport damage.
- Before start-up check that all components mounted by the user are installed correctly and connected pressure-tight with the compressor (pipes, plugs, union nuts, replaced components etc.).
- Before start-up evacuate the refrigeration plant with compressor carefully and then charge with refrigerant.
- Open discharge and suction shutoff valves before starting the compressor.
- Do not start the compressor in vacuum! Operate only with refrigerants charge.
- Corresponding to the conditions of use, surface temperatures of more than 100 °C on the discharge side and below 0 °C on the suction side can be reached.

# Product description

## Use as intended

This operating manual describes the compressor named in the title in the standard version. Bock refrigerant compressors are intended for use in refrigeration plants using the refrigerants stated below and under compliance with operating limits. Any other use of the compressor is not permitted!



Do not use in explosion-risk environments!

## Short description

- Half-hermetic two-cylinder reciprocating compressor with oil pump lubrication.
- Air cooled drive motor.
- Compact dimensions, quiet running, high efficiency.

## Main function parts

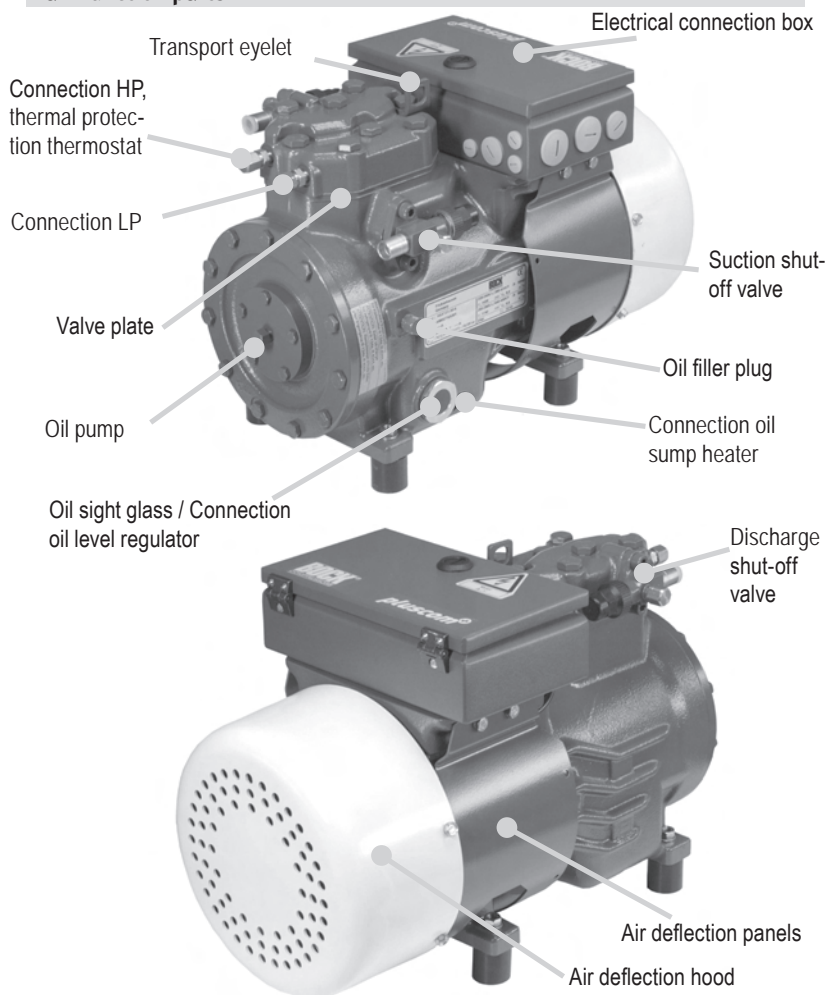

GB

# Product description

## Name plate (example)

D - 72636 Frickenhausen Made in Germany		<b>BOCK</b> ® COMPRESSORS		CE
1	Typ : HA12P/110-4	220-240VΔ/380-420VY -3-	50HZ	6
2	Nr. : AM35830A001	n : 1450 min <sup>-1</sup>	V <sub>th.</sub> : 9,4 m <sup>3</sup> /h	8
3	I <sub>max.</sub> : 6,9/4,0A	265-290VΔ/440-480VY -3-	60HZ	9
4	I <sub>block.</sub> Δ: 43A Y:25A	n : 1740 min <sup>-1</sup>	V <sub>th.</sub> : 11,3 m <sup>3</sup> /h	10
5	p <sub>max.</sub> : ND(LP) / HD(HP)=19/28 bar	IP65	Öl: SP46	12
				13

1	Type designation	6	Voltage, switching, frequency
2	Machine number	7	Rated speed
3	Maximum operating current	8	Swept volume
4	Start-up current (rotor blocked)	9	Voltage, switching, frequency
5	ND (LP): max. admissible stop period pressure intake side	10	Rated speed
	HD (HP): max. admissible working pressure high pressure side	11	Swept volume
ⓘ	Note limits of application diagrams!	12	Oil grade filled by the manufacturer
		13	Protection terminal box
		ⓘ	Electrical accessories can change the IP safety class system!

## Type code (example)

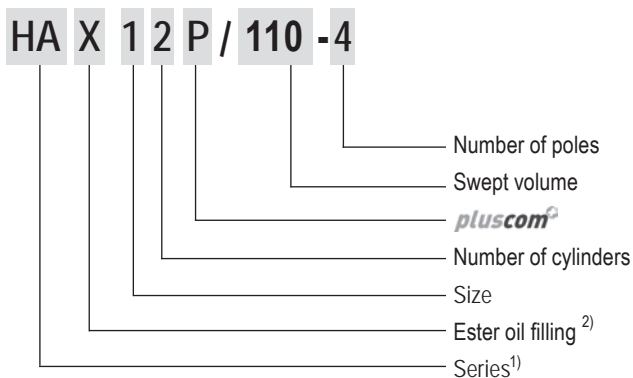

<sup>1)</sup> HA = Hermetic-Air-cooled for the freezing.

<sup>2)</sup> X = Ester oil filling (HFC refrigerant), e.g. R404A, R507.

# Areas of Application

## Coolant

- (H)FCKW / (H)CFC: R22
- HFKW / HFC: R404A/R507

## Oil filling

- The compressors are filled with the following oil grades in the factory:  
for R22: FUCHS Reniso SP 46;  
for R404A/R507: FUCHS Reniso Triton SE 55.  
Compressors with ester oil filling (FUCHS Reniso Triton SE 55) are marked with an X in the type designation (e.g. HAX12P / 110-4)



- **We recommended using the above oil grades for refilling. Alternatives: see excerpt the Bock lubricant table page 19.**

## Limits of application diagrams



- **It is possible to operate the compressor within the operating limits shown in the diagrams. Please note the significance of the shaded areas. Thresholds should not be selected as design or continuous operating points.**
  - **Max. permissible end temperature of the compressor: 140°C**
  - **Max. permissible switching frequency: 8x /h**
  - A minimum running time of 3 min. steady-state condition (continuous operation) must be achieved.
- **For operation with frequency converter:**
  - Achieving the max. permissible power consumption of the drive motor can restrict the operating limits.
- **During operation in the vacuum range, there is a danger of air entering on the suction side. This can cause chemical reactions, pressure rise in the condenser and an excessive compressed-gas temperature. Avoid absolutely any entry of air.**

# Areas of Application

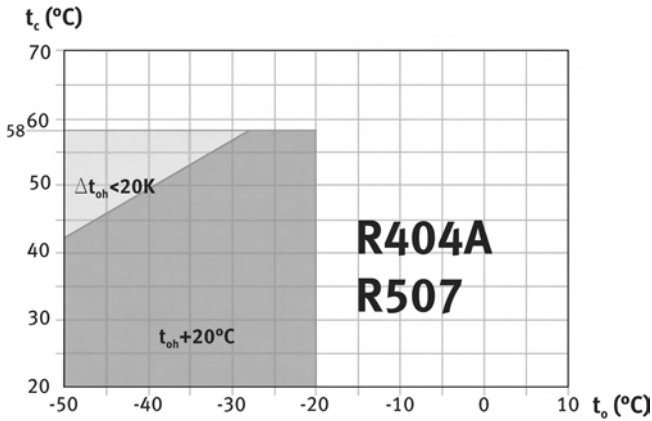
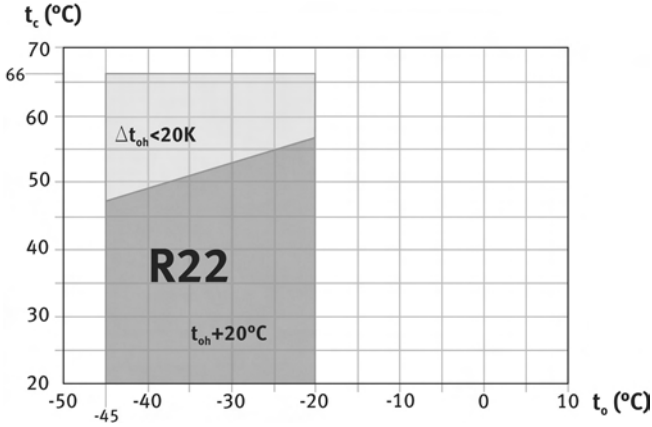

GB



Unlimited application range



Reduced suction gas temperature

$t_o$  evaporation temperature (°C)

$t_c$  condensing temperature (°C)

$\Delta t_{oh}$  suction gas overheating (K)

$t_{oh}$  suction gas temperature (°C)

**Max. allowed operating pressure (HD): 28 bar**

**Design for other areas on request**



# Installation



Compressors are filled with protective gas ex works (approx. 3 bar nitrogen)

- Leave protective gas filling in the compressor up to evacuation.
- Do not open shutoff valves up to evacuation.
- Absolutely avoid entry of air!

## Erection

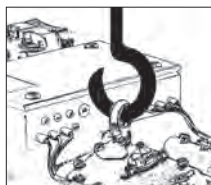

- Use transport eyelet.
- Do not lift manually!
- Use lifting gear!

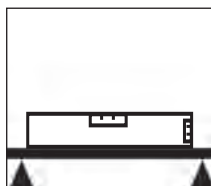

- Erect on a flat surface or frame with sufficient load-bearing ability. Only erect on a slant in consultation with the manufacturer.
- Single compressor preferably on vibration damper.
- Duplex and compound connection basically rigid.

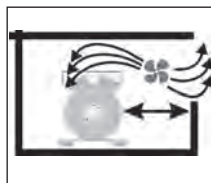

- Ensure there is sufficient space for maintenance work
- Ensure there is sufficient ventilation in the machine room.



- Do not operate in a corrosive atmosphere, dust, vapor or flammable environment.

## Pipe connections

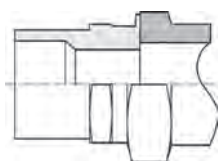

Fig.: schematic

- The **pressure and suction shutoff valves** have graduated inside diameters, so that pipes in the customary millimeter and inch dimensions can be used. The pipe will be immersed more or less deeply according to dimension.



The connection diameters of the shutoff valves are designed for the maximum compressor output. The actually required pipe cross-section must be adapted to the actually refrigeration capacity. The same applies for non-return valves.

# Installation

## Caution when soldering!

- Remove screw connections from the valve for soldering.
- Do not overheat the valve.
- Cool the valve body during and after soldering.

## Pipes

- Pipes and system components must be clean and dry inside and free of scales, metal chippings, and coats of rust and phosphate. Only use hermetically sealed parts.
- Lay pipes correctly. Avoid strong vibrations because of the risk of cracks and breaks. Provide suitable fixed points and/or vibration compensators as required.
- Guarantee a correct oil return.
- Keep pressure losses to an absolute minimum.



A proper run of the suction and discharge line immediately after the compressor is of great importance for the system's smooth running and freedom from vibration.



**Improperly installed pipes can cause cracks and tears, which results in refrigerant loss.**

**A rule of thumb:**

**Always lay the first pipe section starting from the compressor downward and parallel to the drive shaft.**

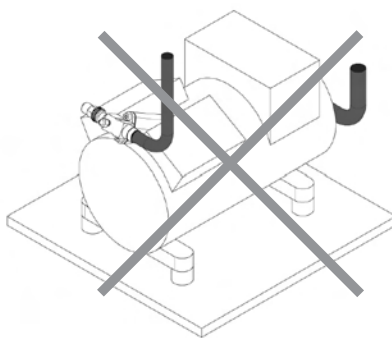
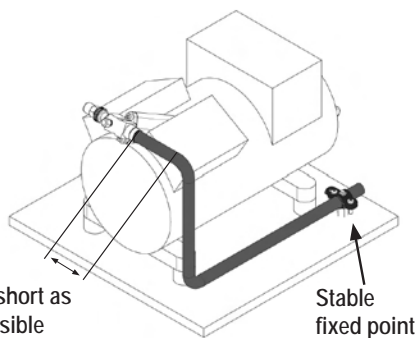

GB

# Montage

## Shut-off valves



Comply with the safety instructions on page 9!

Before opening or closing the shut-off valve, turn the valve spindle seal approx.  $\frac{1}{4}$  of a turn counter-clockwise. After activating the shut-off valve, tighten the valve spindle seal again clockwise.

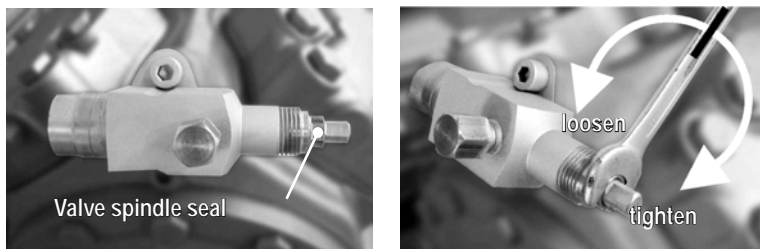
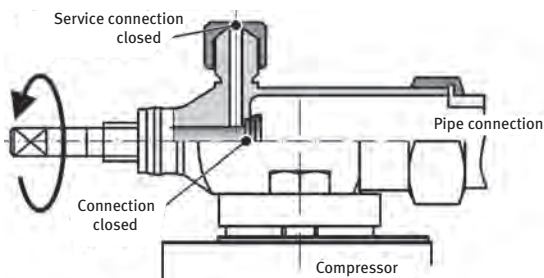

Fig. schematic

## Mode of operation of the screw-down service connections

### Opening the shutoff valve:

Turn the spindle to the left (counterclockwise) up to the stop. Shutoff valve fully opened, service connection closed.



### Opening the service connection:

Turn spindle  $\frac{1}{2}$  – 1 turn to the right. Service connection opened, shutoff valve opened.

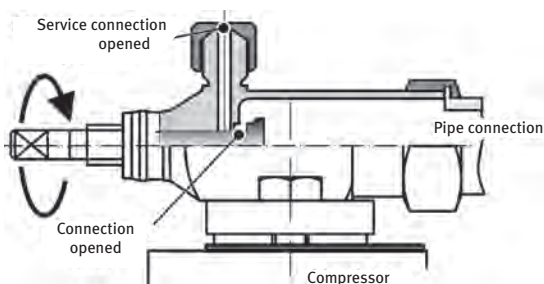

Fig.: schematic

GB

# Electrical system

## Electrical connection



**High voltage! Perform work only with the electrical installation disconnected from the power supply!**



- Make connection of the compressor motor according to the circuit diagram (see inside of terminal box). Comply with local safety regulations for electrical work and the safety standards EN 60204, EN 60335 when connecting.
- For cable lead-through at the terminal box use suitable cable screw connections in correct protective version (see name plate). Use strain relief. Avoid abrasion points on cables.
- **Motor contactors, feed lines and fuses are to be rated according to the maximum operating current (see compressor nameplate).**
- Compare the details for voltage and frequency on the nameplate with the details for the electricity mains supply. **The motor may only be connected up when these details correspond.**

## Connection of the drive motor



The compressor is implemented with an engine for star-delta connection.

Recognition characteristics:

Designation on the nameplate	Designation on the yellow label on the terminal box
$\Delta / Y$	

$\Delta / Y$  - starting is only possible in  $\Delta$  - voltage-range.

Example:

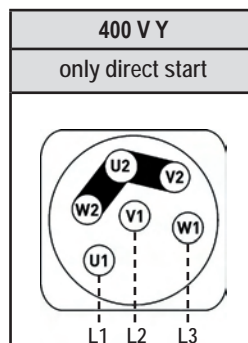
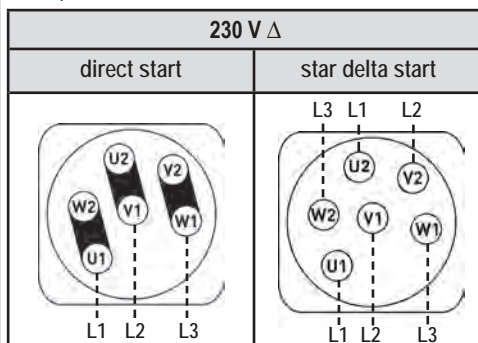

# Electrical system

Wiring diagram for direct start 230 V Δ / 400 VY

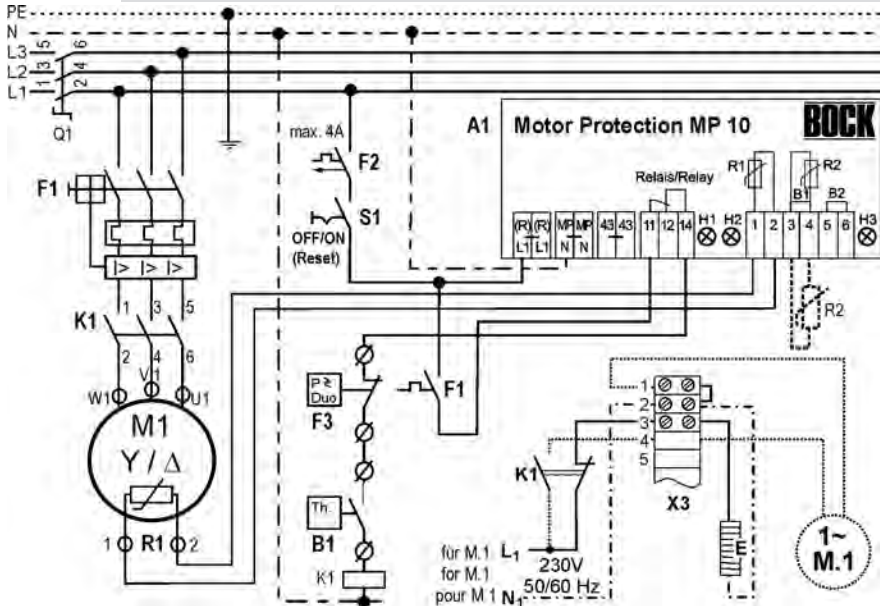

- 1-2 Connections for PTC sensor
- R1 PTC sensor motor winding
- R2 Heat protection thermostat (PTC sensor)
- F1 Safety device load stabilisation circuit
- F2 Fuse control power circuit
- F3 Safety chain (high/low pressure monitoring)
- B1 Enable switch (thermostat)
- Q1 Main switch
- S1 Switch control voltage
- M1 Compressor motor
- M.1 Fan HA
- K1 Mains contactor
- A1 Electronic trigger MP10
- E Oil sump heater
- X3 Terminal strip in the terminal box

# Electrical system

## Electronic trigger MP 10

The compressor motor is equipped with posistor temperature sensors (PTC) which are wired to the electronic trigger MP 10 in the terminal box. The stand-by mode is indicated by the light diode H3 (green) when mains voltage is applied. In the event of overtemperature in the motor winding, the device switches the compressor off and signal lamp H1 lights up red.

In addition, the hot gas side of the compressor can be protected from overheating by a heat protection thermostat (accessories). The signal lamp H2 (red) is intended for this function.



When the device has triggered, this indicates an overload or intolerable operating conditions. Ascertain and eliminate the cause.



The device has a reclosure preventing feature. After eliminating the fault, the device is quit by interrupting the mains power with the external alarm reset switch S1 (see main-line wiring diagram). The reclosure preventing feature is unlocked and LEDs H1 or H2 go off again.

## Connection of the electronic trigger MP 10

The electrical connection of MP 10 is to be completed according to the circuit diagram. The trigger is to be protected with a fuse (F) of max. 4 A, slow-acting. To guarantee the protection function, the electronic trigger is mounted as first element in the control power circuit.

Connections temperature monitoring:

- motor winding: terminals 1 - 2
- hot gas side: terminals 3 - 4



Terminals 1 - 6 on the electronic trigger MP 10 and terminals PTC 1 and PTC 2 on the compressor terminal board may not come into contact with mains voltage. This would destroy the electronic trigger and the PTC sensors.

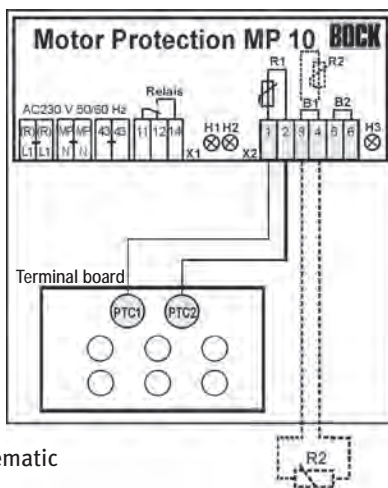

Fig.: schematic

# Electrical system

## Function test of the electronic trigger MP 10

Before starting up and after any faults or changes to the control power circuit of the machine, check the electronic trigger to ensure that it functions properly:

Pos	Procedure	LED H1 red	LED H2 red	LED H3 green
1	<ul style="list-style-type: none"><li>● Interrupt the power supply (L1 or S1)</li><li>● Disconnect the motor temperature sensor connection (terminal 1 or 2)</li><li>● Disconnect the hot gas temperature sensor (if installed) (terminal 3 or 4)</li></ul>	OFF	OFF	OFF
2	<ul style="list-style-type: none"><li>● Switch the power supply on again (L1 or S1).</li><li>● Function check motor temperature sensor: stand-by</li><li>● Function check hot gas temperature sensor: stand-by</li></ul>	ON	ON	ON
3	<ul style="list-style-type: none"><li>● Interrupt mains voltage again (L1 or S1)</li><li>● Connect terminals 1 or 2 respectively 3 or 4 again</li></ul>	OFF	OFF	OFF
4	<ul style="list-style-type: none"><li>● Switch the power supply on again (L1 or S1):</li><li>● MP 10 in stand-by mode</li></ul>	OFF	OFF	ON

The compressor and the motor protection unit MP10 are ready for use if the LED control lamps signal perfect operating functions.

## Information for contactor and motor contactor selection

All protection equipment switching and monitoring devices must comply with the local safety regulations and established specifications (e.g. VDE) and regulations as well as the manufacturer's specifications. Use **motor protector switch!** Motor contactors, feed lines and fuses are to be rated according to the maximum operating current (see name plate). A max. 7 times the permissible operating current according to the compressor name plate is set as short circuit triggering current.

## Fan motor

The ventilator motor for cooling the compressor is already wired in the terminal box. Please consult the main-line wiring diagram in the terminal box for the power supply and triggering via the compressor contactor. The ventilator motor is protected by a pressure controller.

Electrical data: 230 V / 1 / 50 ... 60 Hz, 40 W, 0,3 A

GB

# Start-up

## Preparations for start-up

The compressor has undergone trials in the factory and all functions have been tested. There are therefore no special running-in instructions.

Check the compressor for any signs of transport damage!



**To protect the compressor from intolerable operating conditions, high- and low-pressure pressostats.**

**Comply with the accident prevention regulations!**

## Pressure strength test

The compressor was tested in the factory for pressure strength. If the entire plant should be subjected in addition to a pressure strength test, then observe the following:

- Test the cold circuit according to EN 378-2 (or a corresponding safety standard).
- Perform the pressure strength test preferably with dry nitrogen (N<sub>2</sub>).
- Do not mix any refrigerant with the testing medium (N<sub>2</sub>), since otherwise shifting the ignition limit into the critical range is possible.



**By no means the compressor may be pressure tested with oxygen or other industrial gases!**

**The maximum permissible operating pressure of the compressor may not be exceeded during the entire testing process (see name plate information)!**

## Tightness test

- Perform the tightness test of the refrigeration plant according to EN 378-2 (or a corresponding safety standard) without inclusion of the compressor (preferably dried with N<sub>2</sub>).
- Do not add any refrigerant to the testing medium in case otherwise shifting the ignition limit into the critical range is possible.

## Evacuation

- Firstly evacuate the plant, then include the compressor in the evacuation process.
  - Pressure relieve the compressor.
  - Open suction and pressure shutoff valve.
- Evacuate with the vacuum pump on the suction and high pressure side.
- Vacuum < 1,5 mbar with shutoff pump.
- Repeat the process several times if necessary.



**Do not start the compressor in vacuum. Apply no voltage - also not for test purpose (may be operated only with refrigerant).**

**In the vacuum the spark-over and creepage current distances of the terminal board connection bolts shorten, this can lead to winding and terminal board damage.**



# Start up

## Filling with coolant



Wear personal safety gear!

- Check that the compressor suction and discharge shut-off valves are open.
- With the compressor switched off, fill the liquid coolant directly into the condenser or receiver, breaking the vacuum.
- If the coolant needs topping up after starting the compressor, it can be topped up in vapour from on the suction side, or, taking suitable precautions, also in liquid from at the inlet to the evaporator.



- **Avoid overfilling the machine with coolant.**
- **To avoid shifts in concentration, zeotropic coolant blends (e.g. R407C) must always only be filled into the refrigerating system in liquid form.**
- Do not fill liquid coolant in the suction shut-off valve on the compressor.
- Do not mix additives with the oil and coolant.

## Start-up



Both shut-off valves - the suction and the discharge shut-off valve - must be opened before starting the compressor!

- Check that the safety and protection devices (pressure switch, motor protection, electrical contact protection measures tec.) are all functioning.
- Switch the compressor on.
- Check the oil level in the compressor, It should be visible in the sight glass.



**If larger quantities of oil have to be topped up, there is a risk of oil liquid shocks. In this case, the oil return has to be checked.**

- On reaching equilibrium (constant operating conditions), check that the system maintains the permitted operating conditions.
- When the whole system is running perfectly, we recommend drawing up a final protocol stating all important data and measured values.

## Liquid sluggings



Liquid slugging can cause damage to the compressor and leakage of coolant.



**To avoid liquid slugging, the following points should be observed:**

- The whole plant must be properly designed.
  - All components must be rated to be compatible with each other with regard to output (particular evaporator and expansion valve).
  - Suction gas overheating at the compressor entrance should be **min. 7 - 10 K** (check setting of the expansion valve).
  - The machine must reach a state of equilibrium.
  - Particular in critical systems (e.g. several evaporator points), measures are recommended such as replacement of liquid traps, solenoid in the liquid line etc.
- Coolant should not move in the compressor when the machine is at a standstill.

# Startup

## Connection of oil level regulator

The connection "O" is provided for installing an oil level regulator. A corresponding adapter must be obtained from the trade.

# Maintenance

## Safety instructions



### Before starting any work on the compressor:

- Switch the machine off and secure it against being switched back on.
- Relieve machine from the system pressure.

### After maintenance has been performed:

- Connect safety switch.
- Evacuate compressor.
- **Cancel switch-on blockage.**



### Avoid entry of air into the plant!

Ester oil behaves very strongly hygroscopically. The humidity bonded in the oil cannot be removed sufficiently by the evacuation process. Therefore very careful handling is required!

The compressor is to be kept in a clean, orderly condition by suitable care. In order to guarantee optimum operating safety and service life of the compressor, we recommend that you carry out the following servicing and checks at regular intervals:

- **Oil change** including cleaning the oil intake filter:
  - not mandatory in series machines produced in the factory
  - for field installation or operation in the application limit range, first oil change after approx. 100 - 200 operating hours, then approx. every 3 years or 10,000 - 12,000 operating hours.
  - Dispose of used oil properly, comply with national regulations.
- **Regular checks:** Tightness, running noise, pressures, temperatures, function of the additional equipment such as oil sump heating, pressure switches: annually. Observe national regulations.

## Spare part recommendation

HA12P / ...	60-4, 75-4	90-4, 110-4
Designation	Art.-Nr.	Art.-Nr.
Valve plate kit	80352	80353
Seal kit	80339	
Oil pump kit	08324	
Oil sump heater kit, 110 - 240 V	08028	



Only use original Bock spare parts!

# Maintenance

## Accessories

Information to available accessories finds you in our product catalog as well as under [www.bock.de](http://www.bock.de).

## Screwed unions



Various installation, maintenance and servicing work entails intervention in the compressor. All work must therefore be performed with compliance with the given safety instructions. The screw starting torques are to be considered!  
Current table under [www.bock.de](http://www.bock.de).

## Lubricants

The oil grade filled as standard in the factory is noted on the name plate. This oil grade should be used preferably. Alternatives to this see following lubricant table.

Bock standard oil grade	Recommended alternatives	
For HFCKWs (e.g. R22)		
FUCHS Reniso SP 46	MOBIL SHC 425 SHELL Clavus SD 22-12	SUNOIL Suniso 4GS TEXACO Capella WF 46
For HFKWs (e.g. R404A, R507)		
FUCHS Reniso Triton SE 55	FUCHS SEZ 32 ICI Emkarate RL 46 S	MOBIL Arctic AL 46 SHELL Clavus R 46

Refer to the Bock lubricant tables for information about further suitable oils.

## Decommissioning



**For major repairs or during shutdown: Observe safety instructions, p. 18**

Close shut-off valves at the compressor. Suction off refrigerant (do not blow off!) and dispose of it according to regulations. Open screw connections or flanges on the compressor valves and remove compressor, if necessary with lifting gear. If the compressor oil dispose correctly. Environmental regulations and national regulations consider!

# Technical Specifications

Type	Cylinders	Swept volume 50 / 60 Hz (1450 / 1740 rpm)	Electrical Specifications ③				Weight	Connections ④		Oil filling	Sound pressure level
			Voltage ①	Operating current max. ② Δ / Y	Power consumption max. ②	Start Up current (rotor blocked) Δ / Y		Discharge line DV	Suction line SV		
HA12P/60-4		m <sup>3</sup> /h 5,40 / 6,40	A 5,5 / 3,2	kW 1,7	A 40 / 23	kg 52	mm (inch)	mm (inch)	Ltr.	59,5 / 59	
HA12P/75-4	2	6,70 / 8,10	5,9 / 3,4	1,8	40 / 23	53	12 (1/2)	12 (1/2)	0,9	60 / 59,5	
HA12P/90-4		8,00 / 9,60	6,6 / 3,8	2,0	43 / 25	53				60,5 / 59,5	
HA12P/110-4		9,40 / 11,30	6,9 / 4,0	2,2	43 / 25	53				61 / 60	

① Tolerance ( $\pm 10\%$ ) applied to the average of the tension range.

Other voltages and current types on request.

② Take account of the max. operating current / max. power consumption when designing contactors, leads and fuses. Switch: Service category AC3.

③ All data are based on the mean value of the voltage range.

④ For soldering joint

⑤ L = deep freezing range ( $-35 / 40^{\circ}\text{C}$ ), M = normal refrigerating range,

( $-10 / 45^{\circ}\text{C}$ ), measuring distance: 1m, Compressor operating at 50 Hz (1450 rpm), coolant R404A.

The data are mean values, tolerance  $\pm 2$  dB(A).

# Dimensions and connections

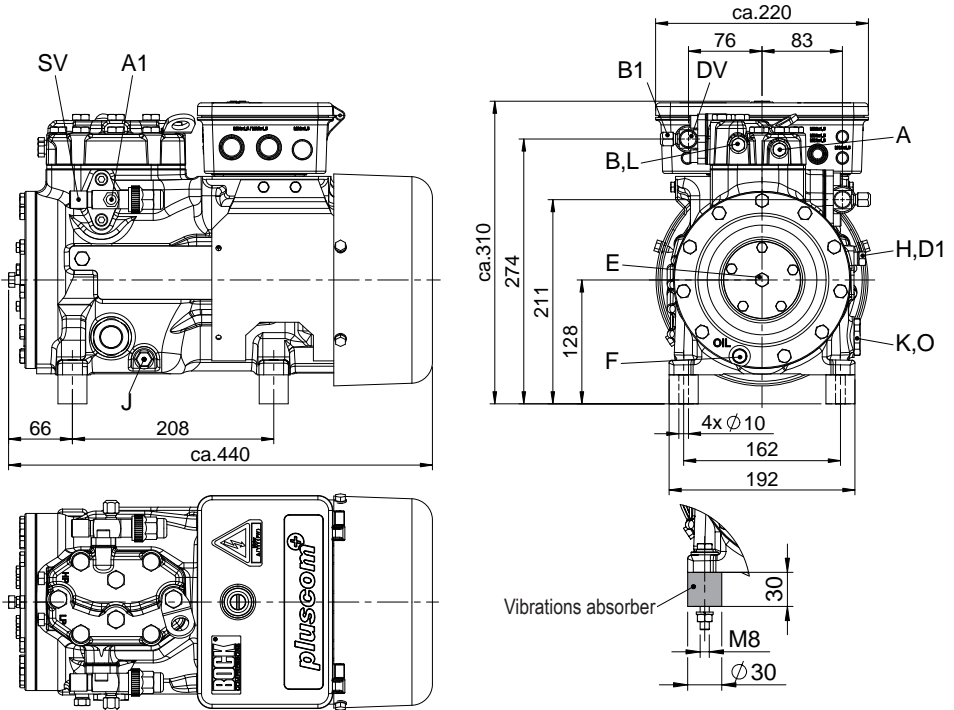

Dimensions in mm - Subject to change without notice

SV	Suction line	Technical specifications, p. 20	
DV	Discharge line		
A	Suction side connection, not lockable		1/8" NPTF
A1	Suction side connection, lockable		7/16" UNF
B	Discharge side, not lockable		1/8" NPTF
B1	Discharge side, lockable		7/16" UNF
D1	Oil return from oil separator		1/4" NPTF
E	Oil pressure gauge connection		1/8" NPTF
F	Oil drain		M8
H	Oil filling bung		1/4" NPTF
J	Oil sump heater		Ø 15 mm
K	Sight glass		1 1/8" - 18 UNEF
L	Heat protection thermostat		1/8" NPTF
O	Oil level controller		1 1/8" - 18 UNEF

**GB**

# Conformity and manufacturer's declaration

**DECLARATION OF CONFORMITY CE 96**  
**for use of the compressors within the European Union**  
(as per EU low voltage directive 73/23/EEC, in the version 93/68/EEC)

We herewith declare that the hermetic refrigerating compressors named in the title comply with the low voltage directive 73/23/EEC in the version 93/68/EEC.

**Applied harmonised standard**

EN 60335-2-34

When installing our products in a machine,  
the following manufacturer declaration must be taken into consideration.

---

**MANUFACTURER DECLARATION**  
**for use of the compressors within the European Union**  
(referring to the EU machinery directive 98/37/EEC, annex II B)

We herewith declare that the hermetic refrigerating compressors named in the title in the version supplied by us are intended for installation in a machine which complies with the machinery directive 98/37/EEC.

**Applied harmonised standards**

EN ISO 12100-1	EN 349	EN 60529
EN ISO 12100-2	EN 60204-1	

It is however not permitted to start up our products before the machine in which they are integrated has been tested according to the corresponding statutory regulations and declared to be conforming in all points.

---

**GB**

**PED CLASSIFICATION**  
(as per EU Pressure Equipment Directive 97/23/EEC)

The compressor is not subject to the EU Pressure Equipment Directive.

Frickenhausen, 07.05.2004

  
Dr. Harald Kaiser  
Technical director



[www.bock.de](http://www.bock.de)

Bock Kältemaschinen GmbH  
Benzstraße 7  
D-72636 Frickenhausen  
Telefon +49 7022 9454-0  
Telefax +49 7022 9454-137  
mail@bock.de

QUALITY SYSTEM



Art. Nr. 09651-11.08-DGbFEI  
Subject to change without notice.

certified by DQS according to  
DIN EN ISO 9001 Reg. No. 2177