

MiniMax[®] NT Series

POOL & SPA HEATERS SERVICE MANUAL

⚠ WARNING

FOR YOUR SAFETY - READ BEFORE OPERATING

Warning: If you do not follow these instructions exactly, a fire or explosion may result, causing property damage, personal injury or loss of life. For additional free copies of this manual; call (800) 831-7133.



⚠ WARNING

Warning: Improper installation, adjustment, alteration, service or maintenance can cause property damage, personal injury or death. Installation and service must be performed by a licensed qualified installer, service agency or the gas supplier.

For Your Safety

WHAT TO DO IF YOU SMELL GAS

- Do not try to light any appliance.
- Do not touch any electrical switch; do not use any phone in your building.
- Immediately call your gas supplier from a neighbor's phone. Follow the gas supplier's instructions.
- If you cannot reach your gas supplier, call the fire department.

Do not store or use gasoline or other flammable vapors and liquids in the vicinity of this or other appliances.

Pentair Pool Products, Inc.

1620 Hawkins Ave., Sanford, NC 27330 • (919) 774-4151
10951 W. Los Angeles Ave., Moorpark, CA 93021 • (805) 523-2400



Table of Contents

Introduction	3
Important Notice	3
Code Requirements	3
Safety Rules	4
Installation Tips	4
Dimensions	5
Installation Outdoors/Indoors	6
Installation on Floors Constructed of Combustible Materials	6
Gas Requirements	7-8
Gas Line Installations	7
Sediment Traps	7
Pipe Sizing for Gas Line Installations	8
Residential Propane 2 Stage Regulation	8
Residential natural Gas 2 Stage Regulation	8
Testing Gas Pressure	9
Gas Pressure Requirements	9
Water Connections	10-11
Plumbing Connections	10
Manual By-Pass	10
Valves	11
Below Pool Installation	11
Pressure Switch Adjustment	11
Reversing Headers	12-13
Air Requirements	14-17
Venting — Indoor Installations	14 - 16
Venting — Outdoor Installations	17
Electrical Wiring	18-21
Wiring Schematic for all Dual Voltage Blowers	19
Wiring Diagram	20
Schematic for Remote Controls (2 and 3 Wire)	21
Basic System Operation	22-24
Heater Operation — Firing Sequence — Ignition Failure — Hard Lock Out	22
Starting Operation — HSI Electronic Ignition Lighting/Operation	23
Chemical Balance	24
Maintenance	25-28
Pressure Relief Valve	25
Spring and Fall Operation — Winter Operation	25
Burner Tray Removal	26
Desooting	27
Reinstalling Heat Exchanger	28
Troubleshooting	29-46
Glossary	47
MiniMax NT (Standard) Parts List & Exploded View (Dual Voltage)	48-49
MiniMax NT Low NOx Parts List & Exploded View (Dual Voltage)	50-51
Warranty Information	Back Cover

Important Notice

MiniMax[®] NT Series

Pool and Spa Heaters

....For the installer and operator of the MiniMax NT Series pool and spa heaters. The manufacturer's warranty may be void if, for any reason, the heater is improperly installed and/or operated. Be sure to follow the instructions set forth in this manual. If you need any more information, or if you have any questions regarding to this pool heater, please contact Pentair Pool Products, Inc. at (800) 831-7133.

These heaters are designed for the heating of swimming pools and spas, and should never be employed for use as space heating boilers, general purpose water heaters, in non-stationary installations, or for the heating of salt water.

⚠ CAUTION

OPERATING THIS HEATER CONTINUOUSLY AT WATER TEMPERATURE BELOW 68° F. WILL CAUSE HARMFUL CONDENSATION AND WILL DAMAGE THE HEATER AND WILL VOID THE WARRANTY.

Do not use the heater to protect pools or spas from freezing if the final maintenance temperature desired is below 68° F. as this will cause condensation related problems.

CODE REQUIREMENTS

The installation must conform with local codes or, in the absence of local codes, with the *National Fuel Gas Code, ANSI Z223.1/NFPA 54* and/or *CSA B149.1, Natural Gas and Propane Installation Codes*. If an external electrical source is utilized, the heater, when installed, must be electrically grounded and bonded in accordance with local codes or, in the absence of local codes, in the USA, with the *National Electrical Code, ANSI/NFPA 7*; in Canada, with *Canadian Electric Code, CSA C22.1-98*.



Safety Rules

1. Spa or hot tub water temperatures should never exceed 104° F. A temperature of 100° F. is considered safe for a healthy adult. Special caution is suggested for young children.
2. Drinking of alcoholic beverages before or during spa or hot tub use can cause drowsiness which could lead to unconsciousness and subsequently result in drowning.
3. Pregnant women beware! Soaking in water above 100° F. can cause fetal damage during the first three months of pregnancy (resulting in the birth of a brain-damaged or deformed child). Pregnant women should stick to the 100° F. maximum rule.
4. Before entering the spa or hot tub, the user should check the water temperature with an accurate thermometer. Spa or hot tub thermostats may err in regulating water temperatures by as much as 4° F.
5. Persons with a medical history of heart disease, circulatory problems, diabetes or blood pressure problems should obtain their physician's advice before using spas or hot tubs.
6. Persons taking medication which induce drowsiness, such as tranquilizers, antihistamines or anticoagulants should not use spas or hot tubs.

⚠ WARNING

Should overheating occur or the gas supply fail to shut off, turn off the manual gas control valve to the heater. Do not use this heater if any part has been under water. Immediately call a qualified service technician to inspect the heater and to replace any part of control system and gas control which has been under water.

Installation Tips

CAUTION

DO NOT INSTALL HEATER UNDER ANY ROOF OVERHANG NOT HAVING A PROPER RAIN GUTTER.

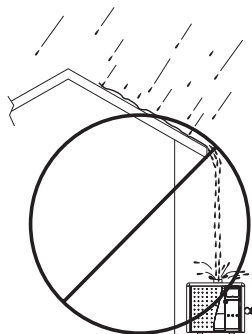

DO NOT PLACE GAS SUPPLY LINE UNION COUPLING INSIDE OF HEATER JACKET.

(Follow Recommendations of National Fuel Gas Code NFPA 54.)

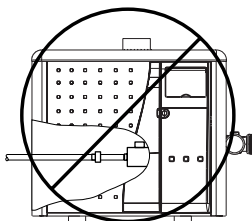

DO NOT RESTRICT ACCESS TO HEATER WITH PIPING.

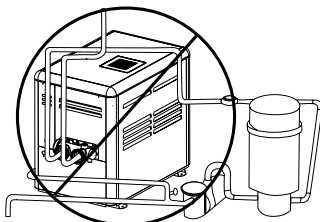

CAUTION

DO NOT INSTALL the heater under an overhang of less than three (3) feet from the top of the heater. The area under the overhang must be open on three sides. Overhangs must be such that flue products are not diverted into living spaces. Heaters installed under overhangs must be protected from direct roof water drainage by gutters and the like.

DO NOT INSTALL the heater in locations which will permit the accumulation of leaves or other combustible material on or around the base of the heater.

DO NOT INSTALL the heater in a location that will allow sprinklers to operate near the heater equipment since the water may cause damage to the controls and/or electronics.

Dimensions

OUTDOOR VENTILATION

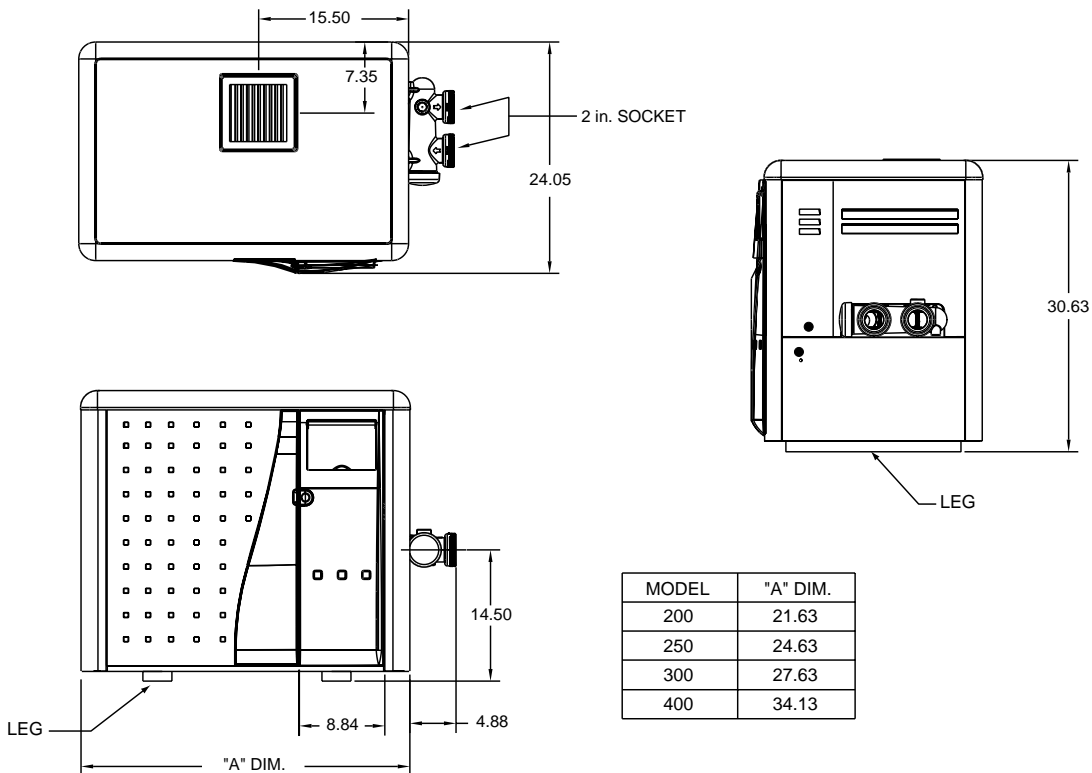

DIMENSIONS IN INCHES

INDOOR VENTILATION

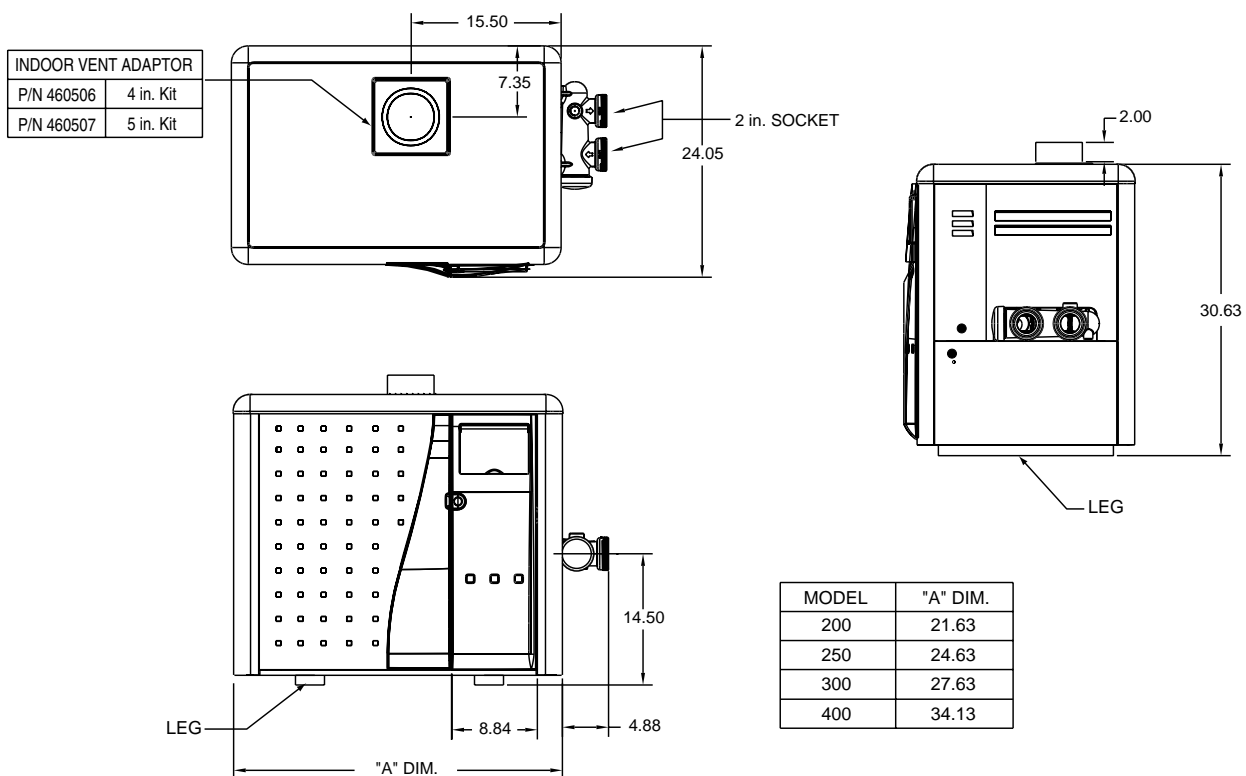

Installation - Outdoors/Indoors

The heater should not be installed closer than 6 inches to any fences, walls or shrubs at any side or back, nor closer than 18 inches at the plumbing side. A minimum clearance of 24 inches must be maintained at the front of the heater. **The heater should be installed at least 5 feet away from the pool or spa.**

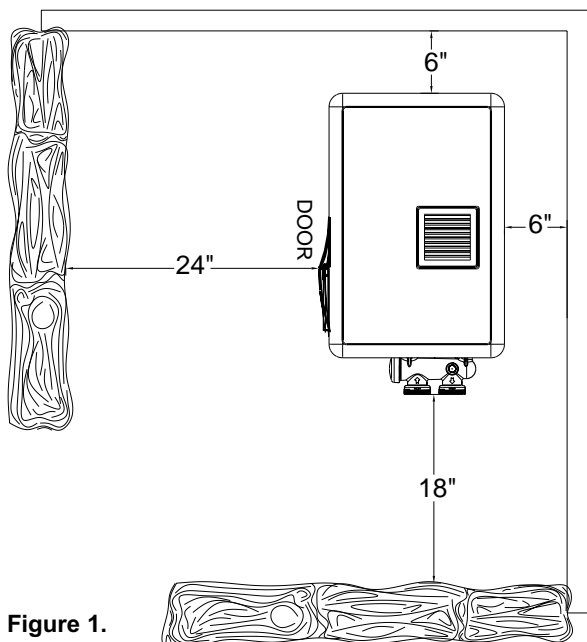

Figure 1.

INSTALLATION ON FLOORS CONSTRUCTED OF COMBUSTIBLE MATERIALS

The heater may be placed on a “combustible floor” using the method listed below:

- The heater must be installed on a non-combustible floor and at least six inches from any combustible material or wall. Construct a non-combustible base from masonry blocks as illustrated in Figure 2.

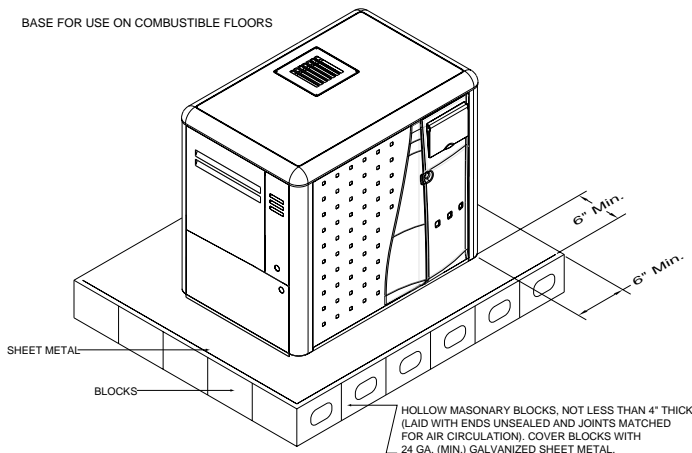

Figure 2.

IMPORTANT!

Under certain conditions, “heavy rains or unusually high winds”, it may be necessary to install an outdoors vent. In this situation, use vent adaptor P/N 460507 and outdoor vent P/N 471357.

NOTE

From the point where the flue products leave the heater, that point **MUST** be a minimum of (4) feet below, and (4) feet horizontally from or (1) foot above any door, window or gravity inlet to a building.

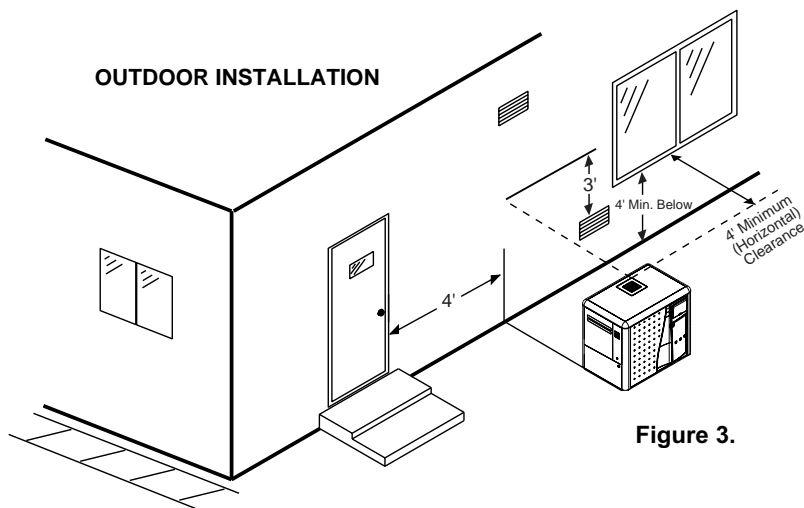

Figure 3.

INDOOR INSTALLATIONS

The heater must be placed in a suitable room on a non-combustible floor or on a non-combustible base and in an area where leakage from heat exchanger or water connections will not result in damage to the area adjacent to the heater or the structure. When such locations cannot be avoided, it is recommended that a suitable drain pan with adequate drainage, be installed under the heater. The pan must not restrict air flow.

Installations in basements, garages, or underground structures where flammable liquids may be stored must have the heater elevated 18 inches from the floor using a non-combustible base. The following minimum clearances from combustible materials must be provided.

	Side	Front	Back	Top
Water Connection	18 in.	24 in.	-	-
Remaining	6 in.	-	6 in.	-
Ceiling Clearance	-	-	-	18 in.*

*To ceiling or roof.

CAUTION

Chemicals should not be stored near the heater installation. Combustion air can be contaminated by corrosive chemical fumes which can void the warranty.

Gas Requirements

GAS LINE INSTALLATIONS

Before installing the gas line, be sure to check which gas the heater has been designed to burn. This is important because different types of gas require different gas pipe sizes. The rating plate on the heater will indicate which gas the heater is designed to burn. Tables 1-5, shown on [page 8](#), shows which size pipe is required for the distance from the gas meter to the heater. The table is for natural gas at a specific gravity of .65 and propane at a specific gravity of 1.5.

When sizing gas lines, calculate three (3) additional feet of straight pipe for every elbow used.

When installing the gas line, avoid getting dirt, grease or other foreign material in the pipe as this may cause damage to the gas valve, which may result in heater failure.

The gas meter should be checked to make sure that it will supply enough gas to the heater and any other appliances that may be used on the same meter.

The gas line from the meter will usually be of a larger size than the gas valve supplied with the heater. Therefore a reduction of the connecting gas pipe will be necessary. Make this reduction as close to the heater as possible.

⚠ CAUTION

The heater and any other gas appliances must be disconnected from the gas supply piping system during any pressure testing on that system, (greater than ½ PSIG).

The heater and its gas connection must be leak tested before placing the heater in operation. **Do not use flame to test the gas line.** Use soapy water or another nonflammable method.

A manual main shut-off valve must be installed externally to the heater. See Figure 4.

SEDIMENT TRAPS

Install a sediment in front of the gas controls. The sediment trap shall be either a tee fitting with a capped nipple in the bottom outlet which can be removed for cleaning, as illustrated below, or a other device recognized as an effective sediment trap. All gas piping should be tested after installation in accordance with local codes. See Figure 4.

⚠ WARNING

Do not install the gas line union inside the heater cabinet. This will void your warranty.

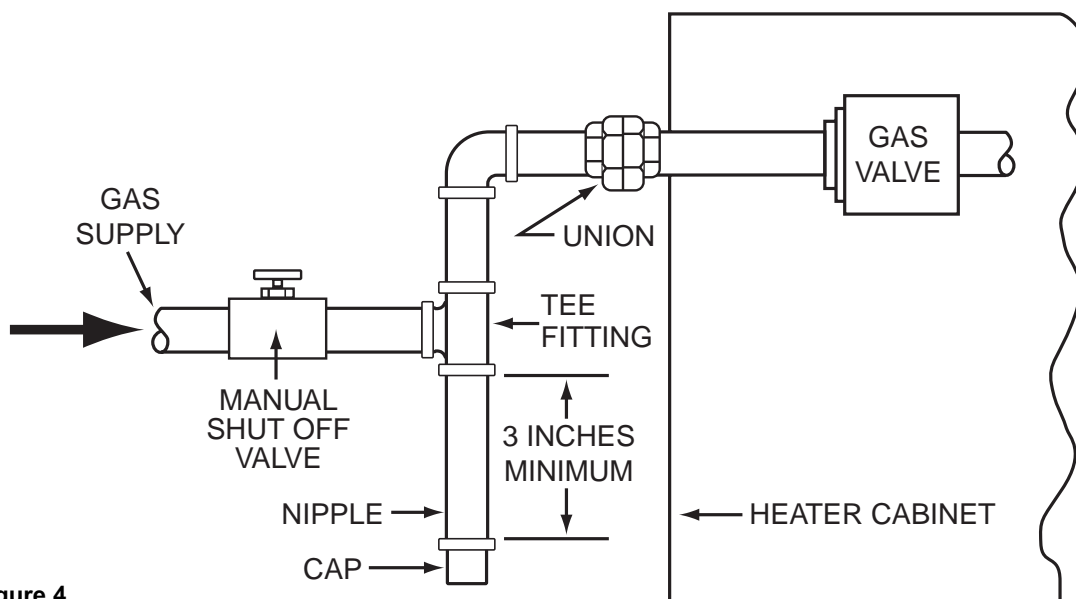

Figure 4.

Pipe Sized For Length Of Run In Equivalent Feet

Table 1.

PIPE SIZING FOR GAS LINE CONNECTIONS														
MAXIMUM EQUIVALENT PIPE LENGTH														
Natural gas at 1000 B.T.U. per Cubic Foot														
Propane Gas at 2500 B.T.U. per Cubic Foot														
MODEL	1/2"		3/4"		1"		1-1/4"		1-1/2"		2"		2-1/2"	
	NAT	PRO	NAT	PRO	NAT	PRO	NAT	PRO	NAT	PRO	NAT	PRO	NAT	PRO
200	-	20'	30'	80'	125'	250'	450'	600'	-	-	-	-	-	-
250	-	10'	20'	50'	70'	150'	250'	500'	600'	-	-	-	-	-
300	-	-	10'	30'	50'	100'	200'	350'	400'	600'	-	-	-	-
400	-	-	-	10'	20'	60'	100'	150'	200'	450'	400'	-	-	-

“RESIDENTIAL” PROPANE 2 STAGE REGULATION

In many Propane gas line installations, the gas supplier and/or installer will utilize a two stage regulation process where by at the supply tank they will install the first stage gas regulator, which would be at a higher pressure, usually 10 psi. This higher pressure allows for a much longer distance and in a much smaller pipe size. Then within a short distance of the pool heater, usually around 24 inches, they will install a second regulator, which is the second stage, and this would be set at the required inlet pressure of the heater.

See “Gas Pressure Requirement Charts”

Stage One "High Pressure" Gas Pipe Sizing			
10 PSI @ 2500 B.T.U. Per CU. FT.			
MAXIMUM EQUIVALENT PIPE LENGTH			
Model	0 to 50 Ft.	50 to 100 Ft.	100 to 150 Ft.
75 through 400	1/2 in.	1/2 in.	1/2 in.

Table 2.

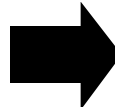

Stage Two "Low Pressure" Gas Pipe Sizing		
Stage 2 set at 14 in. W.C.		
MAXIMUM EQUIVALENT PIPE LENGTH		
Model	0 to 10 Ft.	10 to 20 Ft.
75 through 400	3/4 in.	3/4 in.

Table 3.

“RESIDENTIAL” NATURAL GAS 2 STAGE REGULATION

In many Natural gas line installations, the gas supplier and/or installer may utilize a two stage regulation process where by at the streets main gas supply they will install the first stage gas regulator, which would be at a higher pressure. This higher pressure is usually set at 2 psi or 5 psi and can be for long distances and in a much smaller pipe size. Then within a short distance of the pool heater, generally around 24 inches, they will install a second regulator, which is the second stage. This second stage regulator would be set at the minimum operating pressure for the heater. For “Natural Gas Pentair Pool Heaters” the minimum is 7 inches W.C.

See “Gas Pressure Requirement Charts”

Stage One "High Pressure" Gas Pipe Sizing			
2 PSI @ 1000 B.T.U. Per CU. FT.			
MAXIMUM EQUIVALENT PIPE LENGTH			
Model	0 to 50 Ft.	50 to 100 Ft.	100 to 150 Ft.
75 through 300	1/2 in.	1/2 in.	1/2 in.
350 & 400	3/4 in.	3/4 in.	3/4 in.
5 PSI @ 1000 B.T.U. Per CU. FT.			
75 through 400	1/2 in.	1/2 in.	1/2 in.

Table 4.

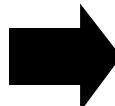

Stage Two "Low Pressure" Gas Pipe Sizing		
Stage 2 set at 7 in. W.C.		
MAXIMUM EQUIVALENT PIPE LENGTH		
Model	0 to 10 Ft.	10 to 20 Ft.
75 through 300	3/4 in.	3/4 in.
350 & 400	3/4 in.	1 in.
Stage 2 set at 7 in. W.C.		
75 through 400	3/4 in.	1 in.

Table 5.

Testing Gas Pressure

1. Push the power switch to “OFF”.
2. Turn the gas valve knob to “OFF”.
3. Remove 1/8 in. NPT plug on the outlet side of the valve and screw in the fitting from the Manometer kit.
4. Connect the Manometer hose to the fitting.
5. Turn the gas valve knob to “ON”.
6. Turn on the heater and read the Manometer.
7. The Manometer must read 4 in. W.C. for natural gas or 11 in. W.C. for propane, on manifold side of the gas valve, while operating.
8. If reading is below specified; check the inlet pressure while the heater is running to make sure of proper supply before attempting adjustments.
9. For adjustment, remove the Regulator Adjustment Cap and using a screwdriver turn the screw clockwise to increase - counterclockwise to decrease gas pressure.

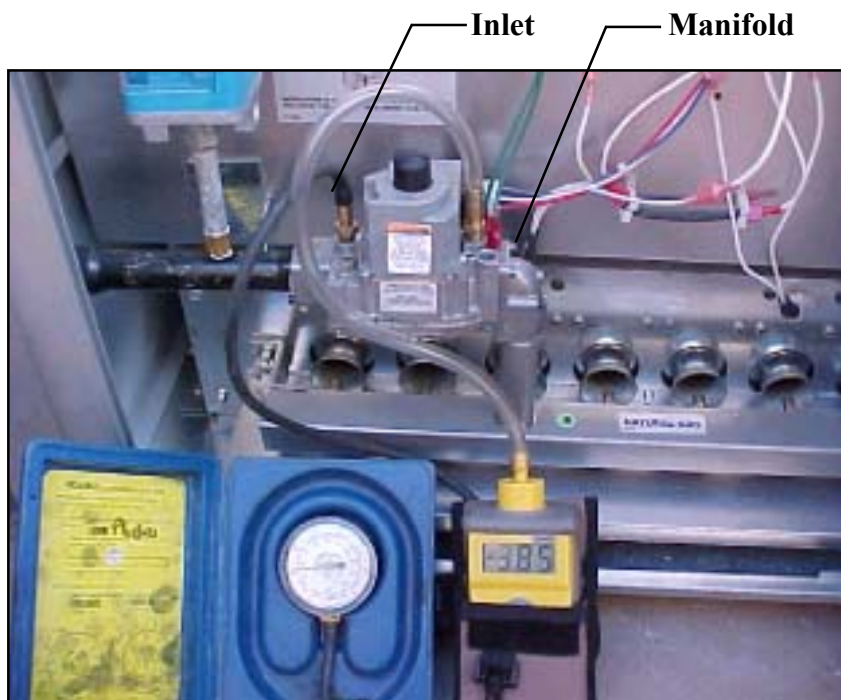

GAS PRESSURE REQUIREMENTS*

	Natural	Propane
Maximum inlet gas pressure	10 in. WC	14 in. WC
Minimum inlet gas pressure	**5 in. WC	12 in. WC
Normal manifold pressure	4 in. WC	11 in. WC

*All Readings are taken with the heater fired. Any adjustments or readings made with heater off will give incorrect readings.

** 6 in. WC for 400 model

CAUTION

The use of Flexible Connectors (FLEX) is **NOT** recommended as they cause excessive high gas pressure drops.

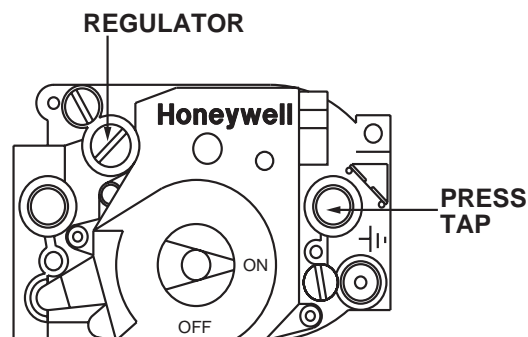

Figure 5.

GAS VALVE

Water Connections

PLUMBING CONNECTIONS

The MiniMax NT Series heater has the unique capability of direct schedule 40 PVC plumbing connections. A set of bulkhead fittings is included with the MiniMax NT Series to insure conformity with Pentair's recommended PVC plumbing procedure.

CAUTION

Before operating the heater on a new installation, turn on the circulation pump and bleed all the air from the filter using the air relief valve on top of the filter. If a Manual By-Pass is installed; temporarily close it to insure that all air is purged from the heater. Water should flow freely through the heater.

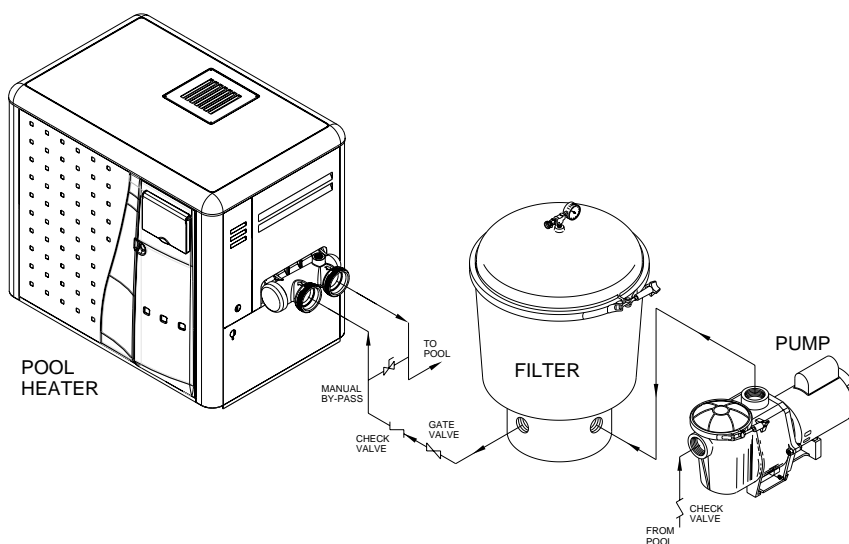

Figure 6.

Do not operate the heater unless water in the pool/spa is at the proper level.

MANUAL BY-PASS

Where the flow rate exceeds the maximum 120 GPM, a manual bypass should be installed and adjusted. After adjustments are made, the valve handle should be removed to avoid tampering.

Adjust By-Pass until a Delta T of 28° - 32° F. is reached.

Model	Min. (GPM)	Max. (GPM) *
200	20	120
250	30	120
300	30	120
400	40	120

* Do not exceed the maximum recommended flow rate for the connecting piping.

Table 6.

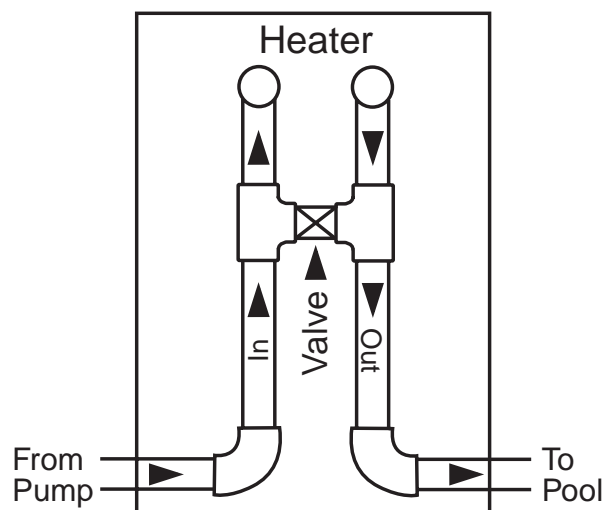

Figure 7.

Water Connections, cont'd.

VALVES

When any equipment is located below the surface of the pool or spa, valves should be placed in the circulation piping system to isolate the equipment from the pool or spa. Check valves are recommended to prevent back siphon.

Periodically check the operation of the valve to insure proper operation.

⚠ CAUTION

Exercise care when installing chemical feeders so as to not allow back siphoning of chemicals into the heater, filters or pump. When chemical feeders are installed in the circulation of the piping system, make sure the feeder outlet line is down stream of the heater, and is equipped with a positive seal noncorrosive "Check Valve", (P/N R172288), between the feeder and heater.

BELOW POOL INSTALLATION

If the heater is below water level, the pressure switch must be adjusted. This adjustment must be done by a qualified service technician.

See following CAUTION before installation.

⚠ CAUTION

BELOW OR ABOVE POOL INSTALLATION

The water pressure switch is set in the factory at 1½ PSI. This setting is for a heater installed at pool level or within 3' above or 3' below. If the heater is to be installed more that 3' above or 3' below, the water pressure switch must be adjusted by a qualified service technician.

FLOW SWITCH

If the heater is installed more the 10' above the pool or more than 10' below the pool level, you will be beyond the limits of the pressure switch and a flow switch must be installed. Locate and install the flow switch externally on the outlet piping from the heater, as close as possible to the heater. Connect the flow switch wires in place of the water pressure switch wires.

PRESSURE SWITCH ADJUSTMENT

1. Backwash filter and clean the pump hair and lint basket before making any adjustment to the pressure switch.
2. Switch the circulation pump on and make sure it is primed.
3. Push the heater power switch on and set the thermostats to their highest temperature settings.
4. Turn the adjustment knob clockwise or away from the micro-switch, until the heater shuts down.

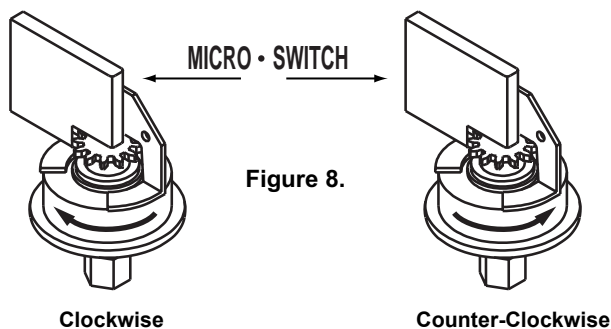

5. Turn the adjustment knob counter-clockwise 1/2 turn and the heater should re-fire.
6. Turn the pump off and the heater should shut down. If heater does not shut down, repeat procedure.
7. Switch pump off and on several times to assure proper adjustment.

Reversing Headers

Reversible Inlet/Outlet Connection

The MiniMax NT Series heater is factory assembled with right side inlet/outlet water connections. The inlet/outlet header can be reversed for left side water connections **without removing the heat exchanger**.

Reversing Water Connections

Tools required:

Phillips Screw Driver
9/16 in. Socket and Wrench
1/2 in. & 9/16 in. Open Wrench

1. Remove the right and left large inspection plates.

It is not necessary to remove the top of the heater to gain access to the headers.



2. Disconnect all wires from the high-limit switches except the short jumper wire.



NOTE

Do **NOT** remove the high-limit and pressure switches or the thermistor from the front header during the reversing procedure, as they will be in the proper location when installed on the left side.

3. Disconnect the pressure switch wiring.
4. Disconnect the temperature sensor wires from the circuit board and feed them back to the header.



5. Remove the 8 bolts holding the main inlet/outlet head.

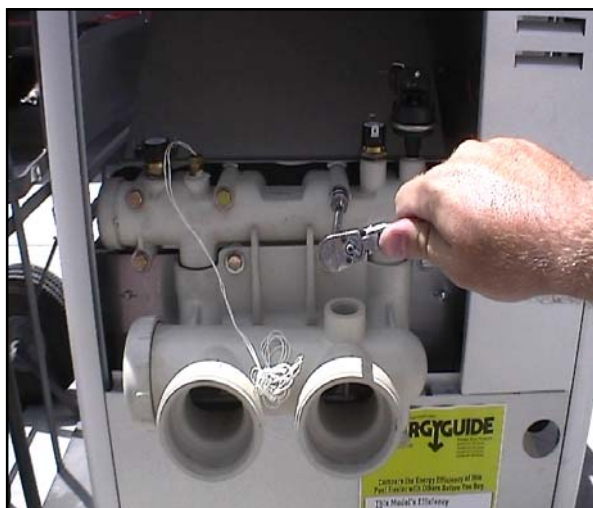

Reversible Inlet/Outlet Connection, cont'd.

On the MiniMax NT Series heater there is insulation installed by the factory on the return head side of the heaters. This insulation is there so that if the heads are reversed in the field, during initial installation of the heater, the high limits will be insulated from the heat radiating from the flue collector.

6. Return head in position before removal. This view shows the insulation installed by the factory. Remove the 8 bolts holding the return head in place.



7. When heads are removed, replace the heat exchanger tube seal gaskets.



8. Exchange the inlet/outlet header with the return header. Lift the insulation to allow the main head to be installed. Align header with the heat exchanger. When head is placed into position, release the insulation; it will now shield the high limits from the heat produced by the flue collector. Install header bolts, and tighten snugly by hand. (This will help avoid cross threading.) When tightening, use a cross pattern starting from the center of the header. **DO NOT over tighten.**



9. Install the temperature sensing probe by passing the wires through the hole provided on the left side of the brace panel. Route wires through the support bracket.



10. Reconnect all the high limit wires and the pressure switch wiring, routing the wires through the same hole as the thermostat sensor wires.



11. Pump and bleed system to check the head for leaks.
12. Reinstall the two large inspection plates on the appropriate side.

*Remember: The inlet and outlet markings on the header are still correct.
Do not plum the heater backwards.*

Air Requirements

INDOOR VENTING—General Requirements

The vent pipe must be the same size or larger than specified adaptor. The MiniMax NT Series heaters are capable of a 360-degree discharge rotation and operate with a positive vent static pressure and with a vent gas temperature less than 400° F.

Please note the allowable vent runs for each stack pipe diameter are different and can not be exceeded. The total length of the horizontal run must not exceed the length that is listed below in the tables.

Note that each 90-degree elbow reduces the maximum horizontal vent run by 8 feet and each 45-degree elbow in the vent run reduces the maximum vent run by 4 feet. See the tables below for the maximum vent lengths using a 90-degree and 45-degree elbows.

The MiniMax NT Series is a “Category III” Appliance and is an induced-draft pool and spa heater which uses positive pressure to push flue gases through the vent pipe to the outside. This requires a completely sealed vent system—single wall vent pipe with sealed-seams and joints. **Flue gases under positive pressure may escape into the dwelling with any cracks or loose joints in the vent pipe, or improper vent installation.** The vent pipe must be of a sealed-seam construction such as those listed for use with “Category III Appliances” and for operating temperatures above 350°. The use of listed thimbles, roof jacks and/or side vent terminals are required; and the proper clearances to combustible materials must be maintained in accordance with type of vent pipe employed—in the absence of a clearance recommendation by the vent pipe manufacturer, the requirements of the Uniform Mechanical Code should be met. **The ventilation air requirements for the MiniMax NT Series heater can be found on page 15.** It is recommended that vent runs over 18 feet be insulated to reduce condensation related problems and/or the use of a condensate trap in the vent run close to the heater may be necessary in certain installations such as cold climates. The MiniMax NT Series is suitable for through-the-wall venting, see table and dimensions below.

Recommended sources for Side-wall vent hood terminals include: The Field Controls Co. (2308 Airport Road, Kingston, NC 28501, (800)742-8368) and Tjernlund Products Inc. (1601 Ninth Street, White Bear Lake, MN 55110, (800) 255-4208)—consult manufacturer for model information and availability.

⚠ CAUTION

Do NOT combine exhaust vent pipes to a common exhaust vent in multiple unit installations. Run separate vent pipes.

Table 7.

45 ft. Maximum Vent Run, 5 in. O.D. vent (Equiv. ft.)			
Additional 90° elbows after first elbow		Additional 45° elbows after first elbow	
Quantity	Reduced Max.	Quantity	Reduced Max.
1 (2 total)	37	(2 total)	41
2 (3 total)	29	(3 total)	37
3 (4 total)	21	(4 total)	33

Table 8.

22 ft. Maximum Vent Run, 4 in. O.D. vent (Equiv. ft.)			
Additional 90° elbows after first elbow		Additional 45° elbows after first elbow	
Quantity	Reduced Max.	Quantity	Reduced Max.
1 (2 total)	14 ft.	(2 total)	18 ft.
2 (3 total)	—	(3 total)	14 ft.
3 (4 total)	—	(4 total)	—

Table 9.

THROUGH WALL VENT KITS FOR HEATERS						
Part Number	Dim. A	Dim. B	Dim. C	Dim. D	Dim. E	Dim. F
471532	4 in. Dia.	6 in. Dia.	8½ in.	6 5/16 in.	12 5/8 in.	10 5/8 in.
471543	5 in. Dia.	8 in. Dia.	8½ in.	8 in.	12 5/8 in.	10 5/8 in.

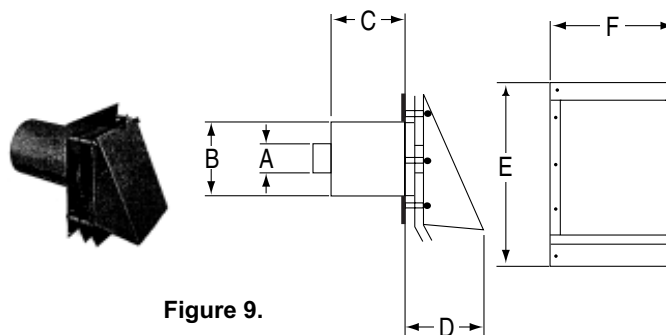

Figure 9.

INDOOR INSTALLATION (USA ONLY)
OUTDOOR SHELTER INSTALLATION (CANADA)

See below for Vent Adaptors

All products of combustion and vent gases must be completely removed to the outside atmosphere through a vent pipe which is connected to the stack adaptor. A vent pipe extension of the same size must be connected to the vent adaptor and extended at least 2 feet higher than highest point of the roof within a 10 foot horizontal radius, and at least 3 feet higher than the point at which it passes through the roof, or as permitted by local code; see Figures 10, 11 and Detail “H” of Figure 13. The vent should terminate with an approved vent cap (weather cap) for protection against rain or blockage by snow.

The heater must be located as close as practical to a chimney or gas vent.

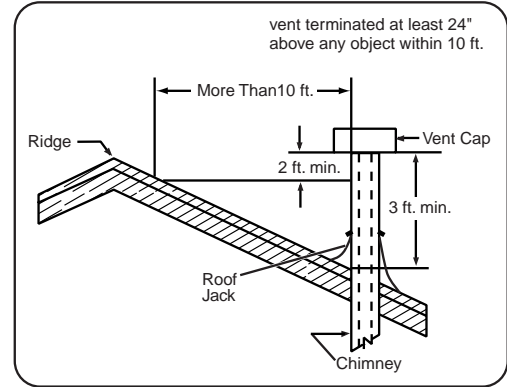

Figure 10.

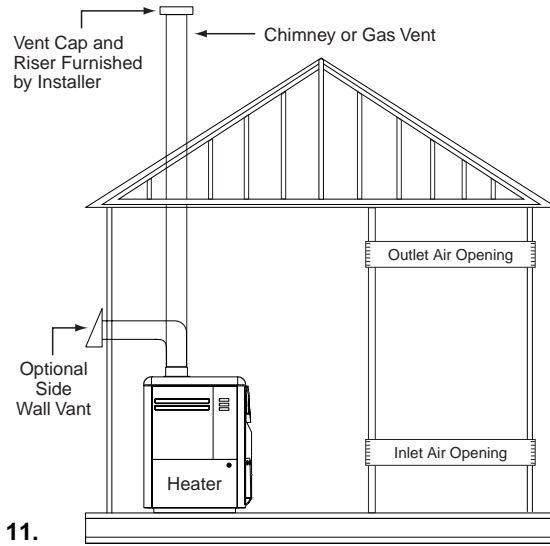
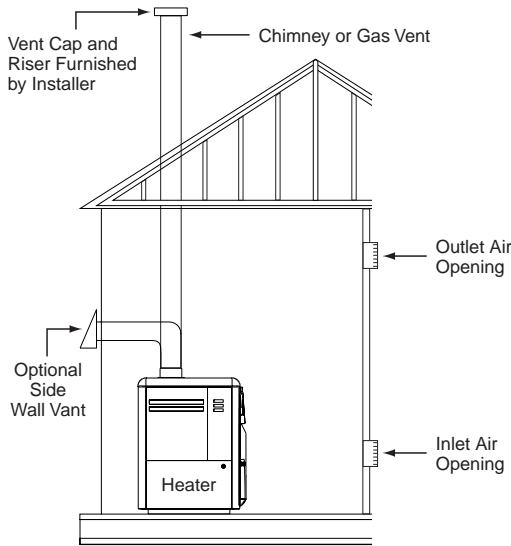

Figure 11.

NOTE

- The heater requires **two uninterrupted air supply openings**; one for ventilation and one to supply air for proper gas combustion. The air supply openings should be sized according to Table 10.
- The openings listed in Table 10. are free open vent area—if the vents incorporate restrictive louvers, the vent openings must be increased to compensate for the area blocked by the louvers (or grills).

Air supply requirements below apply to all MiniMax NT Series heaters

Model	REQUIRED AIR SUPPLY	
	Air for Combustion Sq. In.	Air Ventilation Sq. In.
200	200	200
250	250	250
300	300	300
400	400	400

Table 10.

VENT ADAPTORS (ALL MODELS)

The proper draft hood and adaptor must be installed on the heater as shown below and on [page 14](#):

Part No.	Vent Dia.
460506	4 in.
460507	5 in.

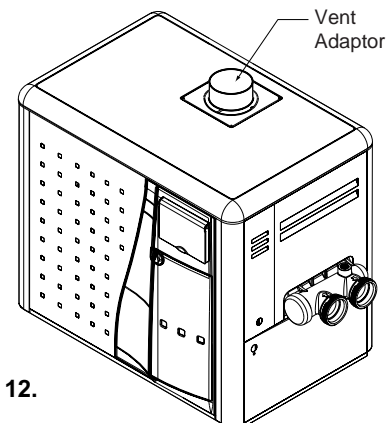
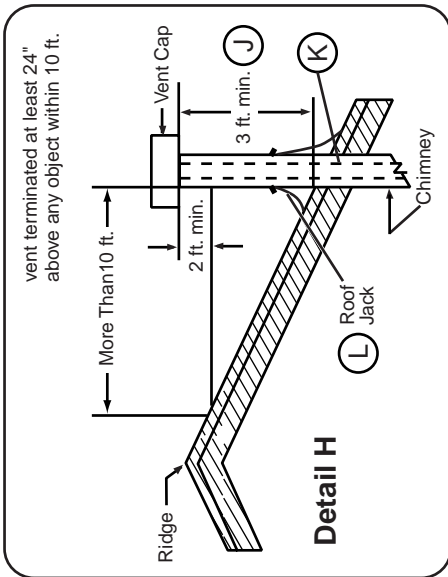

Figure 12.

**INDOOR INSTALLATIONS
MINIMUM VENTING GUIDELINES**



Vent for roof penetration installations:

- (J) must extend at least 3 ft. higher than the point at which it passes through the roof, or as permitted by local code.
- (K) must use a double-wall vent pipe through the roof penetration.
- (L) must terminate with an approved (listed) roof jack, storm collar, and vent/weather cap.

Vent pipe extension:

- must be the same diameter as the vent connector.
- must be suitable for use with category III appliances which have flue gas temperatures of less than 400 deg. F.
- may use a single wall vent pipe with permanently sealed seams and joints.

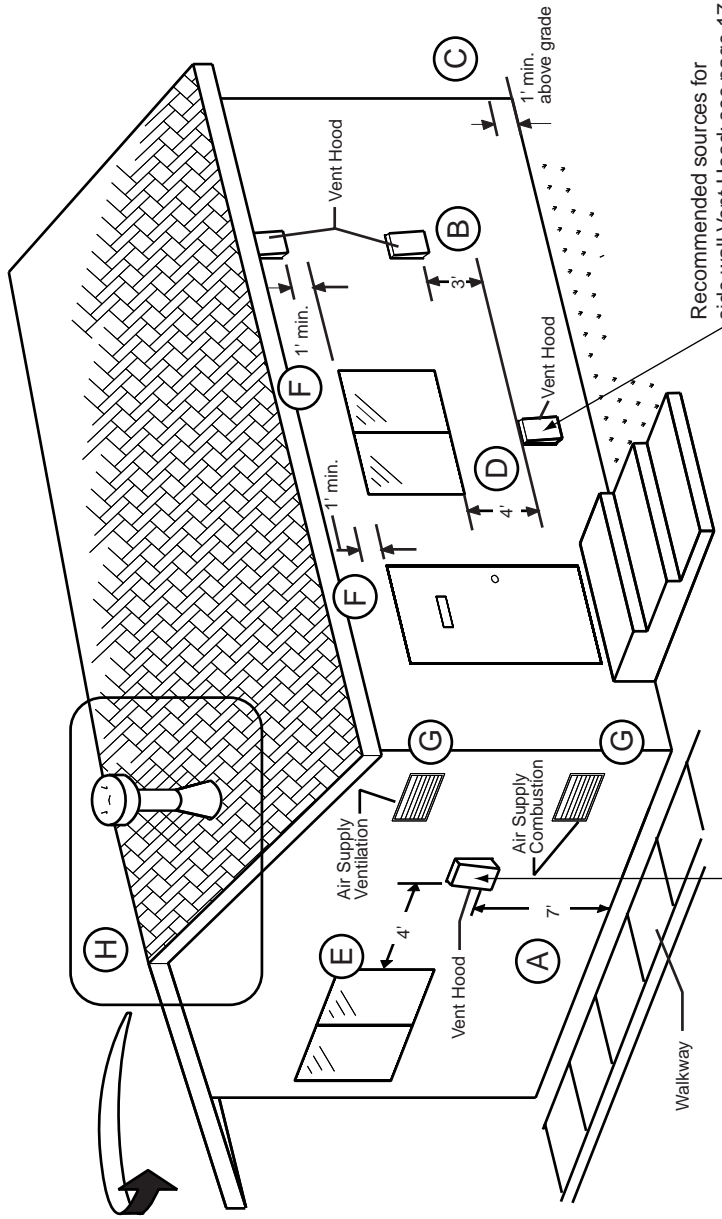

Vent termination for side wall installations:

- (A) must be not less than 7 ft. above public walkways.
- (B) must be at least 3 ft. above any outside air intake located within a 10 ft. radius.
- **must NOT** be within 3 ft. of an inside corner of the structure.
- (C) must be at least 1 ft. above grade.

- must be located the following distances away from any door, window, or gravity air inlet:
 - (D) 4 ft. below
 - (E) 4 ft. horizontally
 - (F) 1 ft. above

Air Supply

- (G) See Air Supply Requirements Table.

(Table 10. on page 15.)

Figure 13.

OUTDOOR INSTALLATION ONLY (Outdoor Shelter Installation in Canada, see page 15)

For outdoor installation with an exhaust grill, the heater must be placed in a suitable area on a level, noncombustible surface. Do not install the heater under an overhang with clearances less than 3 feet from the top of the heater. The area under an overhang must be open on three sides.

IMPORTANT!

- For an outdoor installation it is important to ensure water is diverted from overhanging eaves with a proper gutter/drainage system. The heater must be set on a level foundation for proper drainage.
- Under certain conditions, “heavy rains or unusually high winds”, it may be necessary to install an outdoors vent. In this situation, use vent adaptor P/N 460507 and outdoor vent P/N 471357.

Maintain minimum clearances as indicated below. Install a minimum of 4 feet below, and 4 feet horizontally from any opening to a building, see Figure 14.

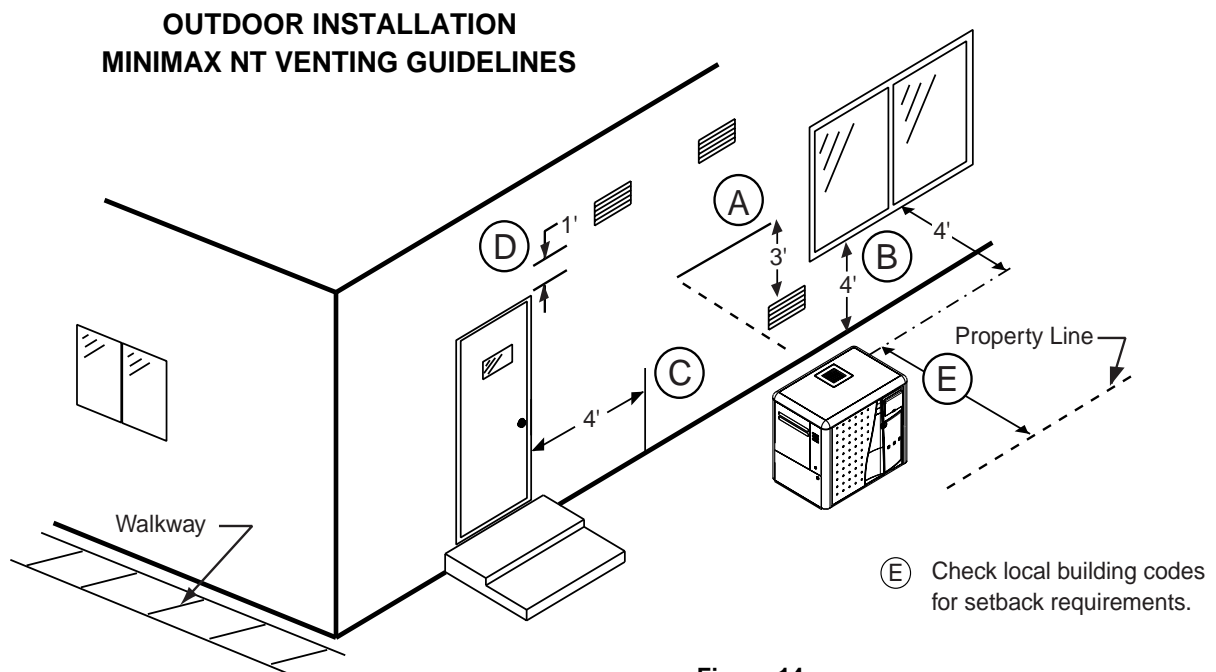

Figure 14.

Vent Termination:

- ★ Must be not less than 7 ft. above public walkways.
- (A) Must be at least 3 ft. above any forced air inlet located within a 10 ft. radius.
- ★ Must be located the following distances away from any door, window, or gravity air inlet:
 - (B) 4 ft. below, or
 - (C) 4 ft. horizontally, or
 - (D) 1 ft. above

Electrical Wiring

Electrical Rating 60 Hz 120 / 240 Volts AC, single phase

NOTE

- The MiniMax NT Series heater is prewired for 240 volt AC connection using the "RED/BROWN" female connector and the "WHITE" common male connector; see below, Figure 15. If you require the heater to be connected to 120 volts AC, remove the "RED/BROWN" female connector from the "WHITE" common connector; now locate the "BLUE" female connector and plug it into the "WHITE" common connector. When connecting the home wiring to the "Line Terminal Block" inside the junction box, follow the polarity as shown below. Connecting to 120 VAC, make sure that you connect the positive wire to the positive terminal (L), the neutral wire is connected to the neutral terminal (N) and the ground is connected to the ground terminal (GND); see below, Figure 16.
- If any of the original wiring supplied with this heater must be replaced, installer must supply (No. 18 AWG, 600V, 105° C. U.L. approved AWM low energy stranded) copper wire or it's equivalent. Thermal fuse wiring must be replaced with 18 AWG, 600V, 150° C temperature rating. Interconnecting wiring to appliance must conform to the National Electrical Code or supercede local (wiring) codes.

WARNING

The installation must conform with local codes or, in the absence of local codes, with the *National Fuel Gas Code, ANSI Z223.1/NFPA 54* and/or *CSA B149.1, Natural Gas and Propane Installation Codes*. If an external electrical source is utilized, the heater, when installed, must be electrically grounded and bonded in accordance with local codes or, in the absence of local codes, in the USA, with the *National Electrical Code, ANSI/NFPA 7*; in Canada, with *Canadian Electric Code, CSA C22.1-98*.

- Always use crimp type connectors when connecting two wires.

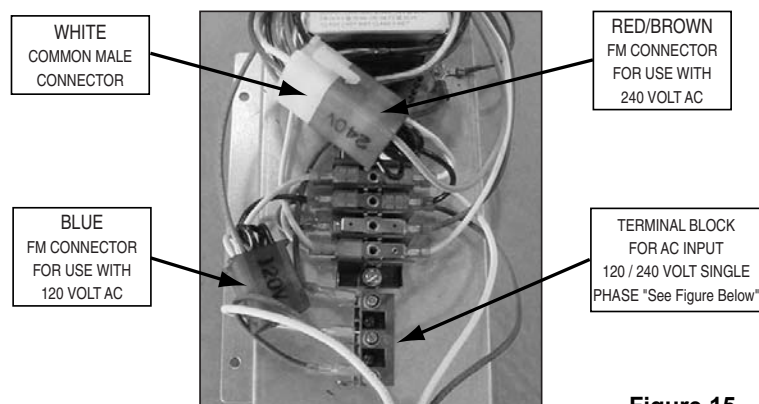

Figure 15.

You might need to open the jacket (upper panel) for servicing the Line Terminal Block as shown in Figures 15 & 16.

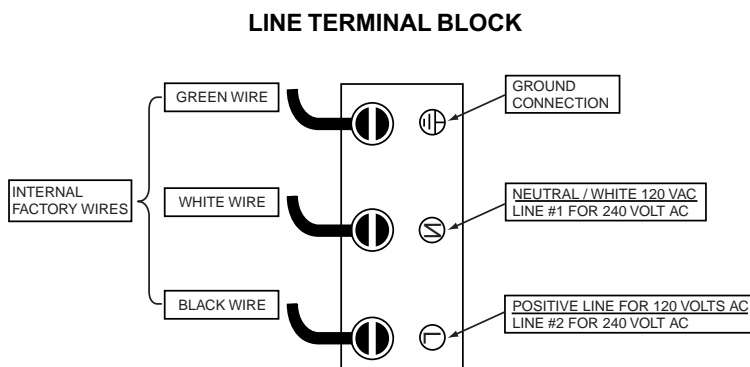

Figure 16.

MiniMax NT Series HSI Electronic Ignition Wiring Diagram (DUAL VOLTAGE w/6800 Control Board)

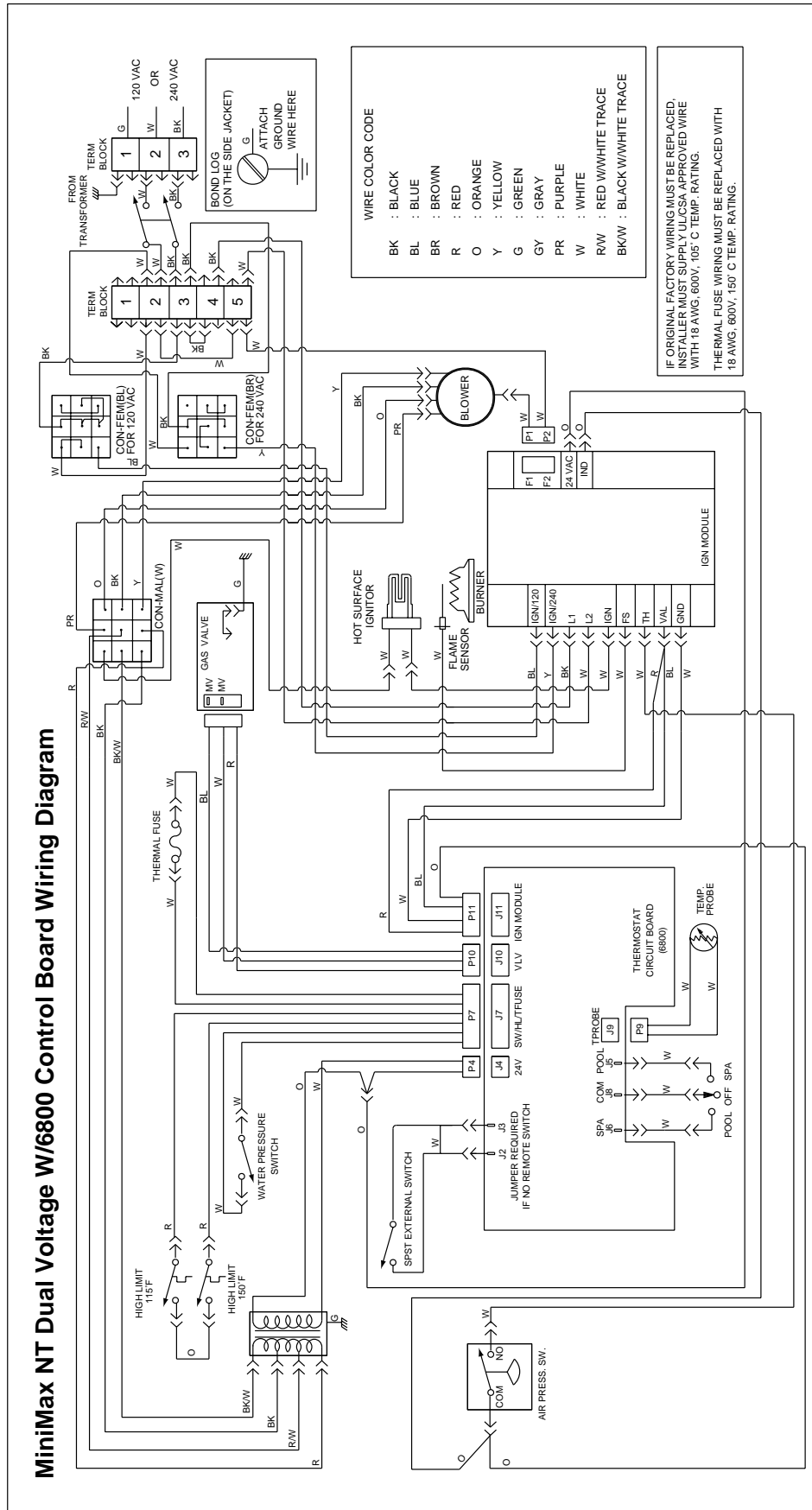

Figure 17.

SCHEMATIC FOR REMOTE CONTROL

3 Wire Remote

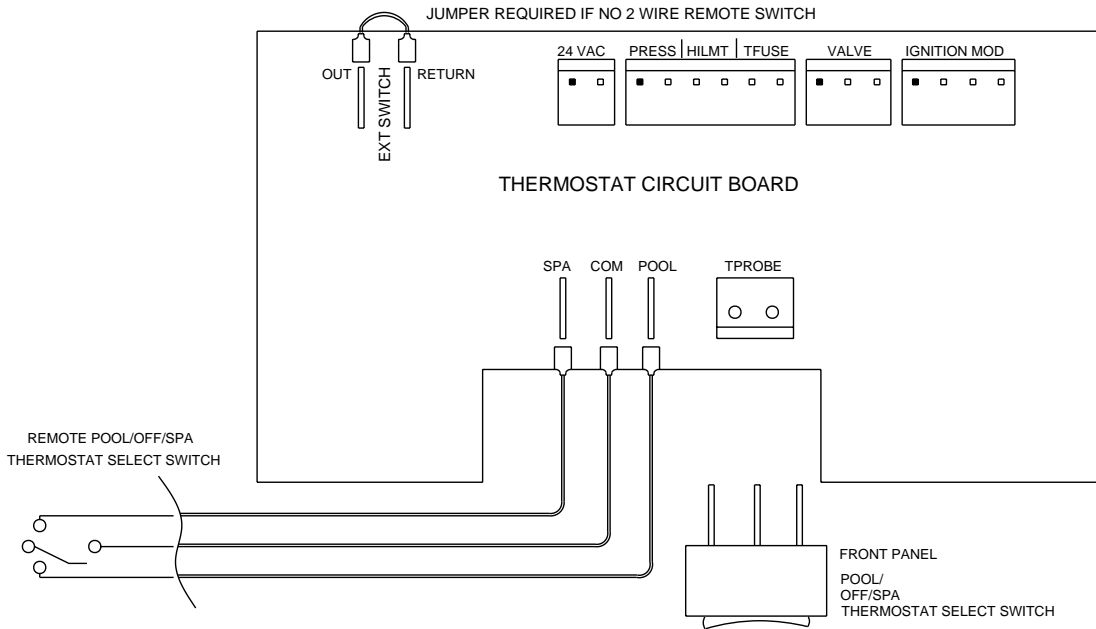

Figure 18.

2 Wire Remote

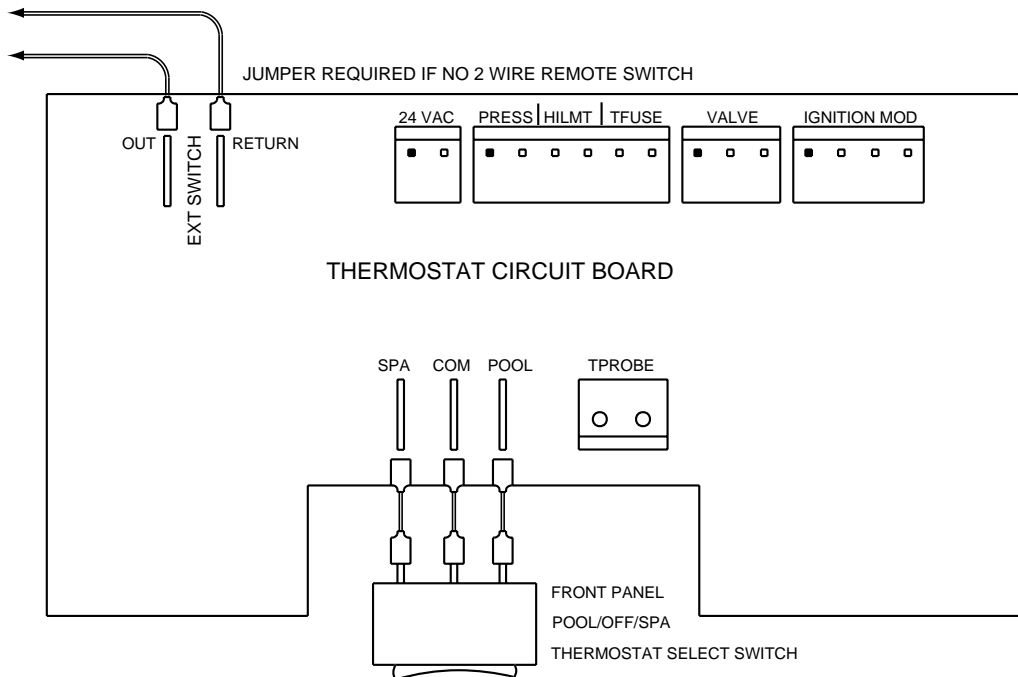

Figure 19.

NOTE: When connecting a remote control to the MiniMax NT Series Heater, you must install the low voltage thermostat wires in separate conduit from **ANY** line voltage wires. Failure to follow these instructions will cause the thermostat relay to react erratically.

Basic System Operation

TO OPERATE HEATER

1. **Start pump, make sure the pump is running and is primed, to close water pressure switch and supply power to heater.** Be sure the pool and/or spa is properly filled with water.
2. Follow the Lighting/Operating instructions on the following page.

FIRING SEQUENCE

1. Pump on.
2. Heater on.
3. T-stats call for heat.
4. Pre-purge for 15 seconds (clears combustion chamber of combustible gas).
5. Hot surface igniter heat up time of 40 seconds.
6. Main valve opens for 7 seconds for flame rectification.
7. Heater runs until desired temperature is reached.
8. Gas valve closes and fan runs for 45 seconds to cool combustion chamber.

IGNITION FAILURE

1. If flame is not rectified in 7 seconds or less the heater goes into pre-purge for 15 seconds, then starts the ignition sequence again.
2. After 3 attempts, the heater goes into hard lock out for 1 hour and tries over again.
(**Note:** The fan will stay running during lockout.)
3. To get out of the 1 hour lock out you must de-energize the heater by cutting power either with the pool / spa rocker switch or internal rocker switch.

HARD LOCK OUT

- ❖ Lock out can occur under the following condition:
 1. Heater has failed to fire on three attempts.
- ❖ When a lock out occurs the heater shows a service light, no heat light, and the exhaust fan stays running until the one hour time out has expired. At that point the heater will attempt to fire three more times. It is important to discover why the lock out has occurred before you attempt to reset the control board.

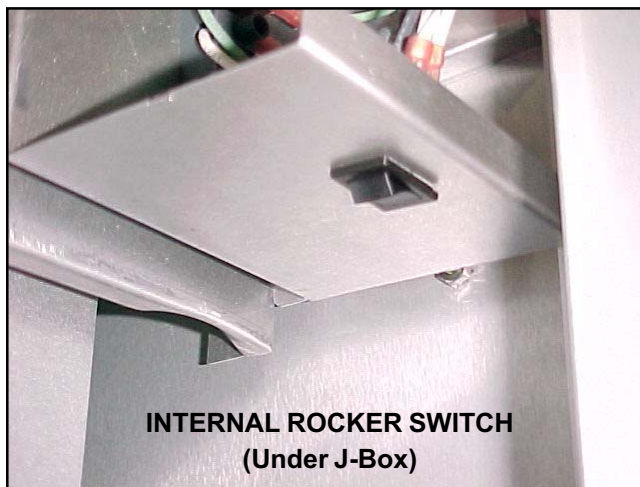

Starting Operation (HSI)

HSI ELECTRONIC IGNITION LIGHTING/OPERATION

FOR YOUR SAFETY: READ BEFORE LIGHTING

⚠ WARNING





If you do not follow these instructions exactly, a fire or explosion may result causing property damage, personal injury or loss of life.

Do not attempt to light the heater if you suspect a natural gas leak. Lighting the heater can result in a fire or explosion which can cause personal injury, death, and property damage.

- A. This appliance does not have a pilot. It is equipped with an ignition device which automatically lights the burners. Do not try to light the burners by hand.
 - B. **BEFORE OPERATING**, smell all around the appliance area for gas. Be sure to smell next to the floor because some gas is heavier than air and will settle on the floor.
- WHAT TO DO IF YOU SMELL GAS**
- Do not try to light any appliance.
 - Do not touch any electrical switch; do not use any phone in your building.
 - Immediately call your gas supplier from a neighbor's phone. Follow the gas supplier's instructions.
- If you cannot reach your gas supplier, call the Fire Department.
 - C. Use only your hand to push in or turn the gas control knob. Never use tools. If the knob will not push in or turn by hand, don't try to repair it, call a qualified service technician. Forced or attempted repair may result in a fire or explosion.
 - D. Do not use this appliance if any part has been under water. Immediately call a qualified service technician to inspect the appliance and to replace any part of the control system and any gas control which has been under water.

OPERATING INSTRUCTIONS

1. **STOP!** Read the safety information above.
 2. Turn off electric power to the heater.
 3. Set the thermostat to the lowest setting.
 4. This appliance is equipped with an ignition device which automatically lights the burners. Do not try to light the burners by hand.
 5. Remove the control access door.
 6. Push in gas control knob slightly and turn clockwise  to "OFF".
- NOTE: Knob cannot be turned to "OFF" unless knob is pushed in slightly. Do not force.
7. Wait five (5) minutes to clear out any gas. If you then smell gas, **STOP!** Follow "B" in the safety information above. If you don't smell gas, go to the next step.
 8. Turn gas control knob counterclockwise  to "ON". See Figure 20.
 9. Replace the control access door.
 10. Set the thermostat to the desired setting.
 11. Turn on the electrical power to the appliance.
 12. If the appliance will not operate, follow the instructions "To Turn Off Gas To Appliance" and call your service technician or gas supplier.

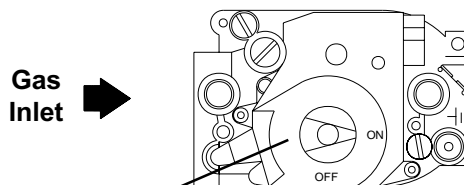



Figure 20. ← Gas control knob shown in "ON" position.

TO TURN OFF GAS TO APPLIANCE

1. Turn off all electric power to the appliance if service is to be performed.
2. Set the thermostat to lowest setting.
3. Remove control access door.
4. Push in gas control knob slightly and turn clockwise  to "OFF". **Do not force.**
5. Replace control access door.

Chemical Balance

POOL AND SPA WATER

Your Pentair Pool Products pool heater was designed specifically for your spa or pool and will give you many years of trouble-free service, provided you keep your water chemistry in proper condition.

Three major items that can cause problems with your pool heater are: improper pH, disinfectant residual, and total alkalinity. These items, if not kept properly balanced, can shorten the life of the heater and cause permanent damage.

CAUTION

Heat exchanger damage resulting from chemical imbalance is not covered by the warranty.

WHAT A DISINFECTANT DOES

Two pool guests you do not want are algae and bacteria. To get rid of them and make pool water sanitary for swimming - as well as to improve the water's taste, odor and clarity - some sort of disinfectant must be used.

Chlorine and bromine are universally approved by health authorities and are accepted disinfecting agents for bacteria control.

WHAT IS A DISINFECTANT RESIDUAL?

When you add chlorine or bromine to the pool water, a portion of the disinfectant will be consumed in the process of destroying bacteria, algae and other oxidizable materials. The disinfectant remaining is called chlorine residual or bromine residual. You can determine the disinfectant residual of your pool water with a reliable test kit, available from your local pool supply store.

You must maintain a disinfectant residual level adequate enough to assure a continuous kill of bacteria or virus introduced into pool water by swimmers, through the air, from dust, rain or other sources.

It is wise to test pool water regularly. Never allow chlorine residual to drop below 0.6 ppm (parts per million). The minimum level for effective chlorine or bromine residual is 1.4 ppm.

pH - The term pH refers to the acid/alkaline balance of water expressed on a numerical scale from 0 to 14. A test kit for measuring pH balance of your pool water is available from your local pool supply store; see Table 11.

Table 11. pH Chart

Strongly Acid			Neutral					Strongly Alkaline						
0	1	2	3	4	5	6	7	8	9	10	11	12	13	14

Muriatic Acid has a pH of about 0. Pure water is 7 (neutral). Weak Lye solution have a pH of 13-14.

RULE: 7.4 to 7.6 is a desirable pH range. It is essential to maintain correct pH, see Table 12.

If pH becomes too high (over alkaline), it has these effects:

1. Greatly lowers the ability of chlorine to destroy bacteria and algae.
2. Water becomes cloudy.
3. There is more danger of scale formation on the plaster or in the heat exchanger.
4. Filter elements may become blocked.

If pH is too low (over acid) the following conditions may occur:

1. Excessive eye burn or skin irritation.
2. Etching of the plaster.
3. Corrosion of metal fixtures in the filtration and recirculation system, which may create brown, blue, green, or sometimes almost black stains on the plaster.
4. Corrosion of copper in the heater, which may cause leaks.
5. If you have a sand and gravel filter, the alum used as a filter aid may dissolve and pass through the filter.

CAUTION: Do not test for pH when the chlorine residual is 3.0 ppm or higher, or bromine residual is 6.0 ppm or higher. See your local pool supply store for help in properly balancing your water chemistry.

RULE: Chemicals that are acid lower pH. Chemicals that are alkaline raise pH.

Table 12. pH Control Chart

6.8	7.0	7.2	7.4	7.6	7.8	8.0	8.2	8.4
Add Soda, Ash or Sodium Bicarbonate		Marginal	Ideal	Marginal	Add Acid			

ALKALINITY High - Low:

"Total alkalinity" is a measurement of the total amount of alkaline chemicals in the water, and control pH to a great degree. (It is not the same as pH which refers merely to the relative alkalinity/acidity balance.) Your pool water's total alkalinity should be 100 - 140 ppm to permit easier pH control.

A total alkalinity test is simple to perform with a reliable test kit. You will need to test about once a week and make proper adjustments until alkalinity is in the proper range. Then, test only once every month or so to be sure it is being maintained. See your local pool dealer for help in properly balancing the water chemistry.

Maintenance

It is recommended that you check the following items at least every six months and at the beginning of every swimming season.

1. Examine the venting system. Make sure there are no obstructions in the flow of combustion and ventilation air.
2. Visually inspect the main burner and the hot surface ignitor. The normal color of the flame is blue. When flame appears yellow, burners should be inspected and cleaned. Check ignitor for damage.
3. Inspect the heat exchanger for soot. Clean as necessary.
4. Remove burner tray and clean burners and main burner orifices.
5. Keep the heater area clean and free from combustibles and flammable liquids.
6. Check wire ends and wire connections. They should be clean and tight.
7. Check the gas pressure as described in this manual.

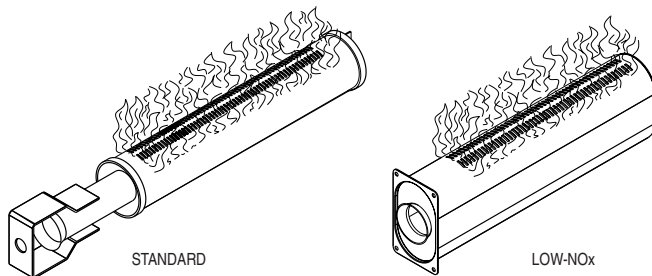

Figure 21.

SPRING AND FALL OPERATION

If the pool is being used occasionally, do not turn the heater completely off. Set the thermostat down to 68° F. This will keep the pool and the surrounding ground warm enough to bring the pool up to a comfortable swimming temperature in a shorter period of time.

WINTER OPERATION

CAUTION

OPERATING THIS HEATER CONTINUOUSLY AT WATER TEMPERATURE BELOW 68° F. WILL CAUSE HARMFUL CONDENSATION AND WILL DAMAGE THE HEATER AND WILL VOID THE WARRANTY.

If the pool won't be used for a month or more, turn the heater off at the main gas valve. For areas where there is no danger of water freezing, water should circulate through the heater all year long, even though you are not heating your swimming pool. **The MiniMax NT Series should not be operated outdoors at temperatures below 0° F. for propane and -20° F. for natural gas.** Where freezing is possible, it is necessary to drain the water from the heater. This may be done by opening the drain valve, located at the inlet/outlet header, (see Figure 22.), allowing all water to drain out of the heater. It would be a good practice to use compressed air to blow the water out of the heat exchanger.

CAUTION

- If the heater has been drained for freezing condition, do NOT turn "ON" until the system is circulating water.
- Water trapped in the heat exchanger can result in freeze damage to the exchanger or headers. Freeze damage is specifically not covered by the warranty.

CAUTION

REMOVE THE FLOW VALVE ASSEMBLY WHEN DRILLING THE HOLE TO INSTALL A PRV, OTHERWISE, YOU WILL DRILL INTO THE VALVE ASSEMBLY.

PRESSURE RELIEF VALVE

In some installations, a pressure relief valve (PRV) is required on the MiniMax NT Series.

To install a PRV, carefully drill a 3/8 in. hole in center of 3/4 in. NPT port (on main header) being careful to drill only through wall at bottom of 3/4 in. NPT port and no deeper—now thread in the 3/4 NPT PRV.

NOTE: (A.S.M.E. version varies slightly. It is of bronze construction, and is supplied with the A.S.M.E. Section IV, pressure relief valve pre-installed at factory.)

Test the relief valve at least once a year by lifting up lever.

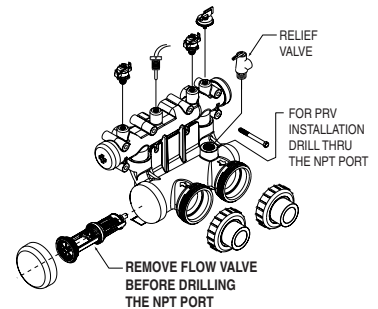
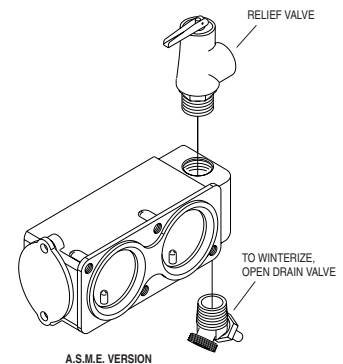

Figure 22.



Maintenance - Burner Tray Removal

At some time during the life of a heater, you may need to inspect and repair the parts of the heater that allows the gas to flow from the gas supply line into the burners. If the heater won't fire and you wish to check these gas controls:

1. Turn off the gas supply.



2. Disconnect the gas union at the heater.
3. Remove the gas pipe installed into the gas valve.
4. Remove the gas valve holding bracket.
5. Remove the gas valve wires.
6. Disconnect the ignition wire.
7. Slide the burner tray out.



MINIMAX NT (STANDARD) VERSION



MINIMAX NT (LOW NO_x) VERSION

8. You can remove the gas valve if you need to check the inlet and outlet screens. (You will have to remove the pilot tubing.)
9. Remove the bracket that holds the burners in place.



10. Remove each burner and check for any blockages.



11. Remove the main burner orifices and check for blockage.

NOTE

If the heater has been off for the winter or has been installed, but not fired for an extended period of time, insects will crawl into these orifices and the pilot orifice and prevent the heater from firing.

NOTE

You can use this procedure if you have to change fuel-type—natural to propane or vice versa. The parts needed to convert the MiniMax NT Series are: **Gas valve, main burner orifices, pilot orifice and module.**

Maintenance - Desooting

COMMON CAUSES OF SOOTING

1. Low gas pressure.
2. Inadequate air supply or inadequate venting.
3. Foreign material in burners and orifices; dirt, spider webs, etc.
4. Excessive water flow can cause condensation which will contribute to sooting.

To remove a light soot formation without removing the heater exchanger:

1. Remove burner tray.

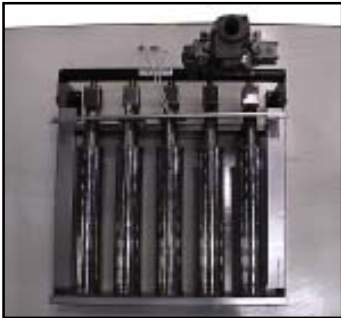

2. Remove top, inner lid, flue collector and baffles.



⚠ WARNING

Soot is combustible — DO NOT USE WIRE BRUSH!

3. Using a brush with plastic or wood bristles, brush the bottom of the tubes and then the top of the tubes.
4. Spray off residue with water. (Repeat steps 3-4 as needed).
5. Brush off burners.
6. Replace burner tray and baffles, then test fire.
7. If flames burn clean, replace baffles, flue collector, and top.

For heavy soot accumulation which cannot be successfully removed by merely brushing, the heat exchanger must be removed from the heater.

1. Disconnect the plumbing at the unions. Remove the thermistor, hi-limit wires from the inlet outlet heater.

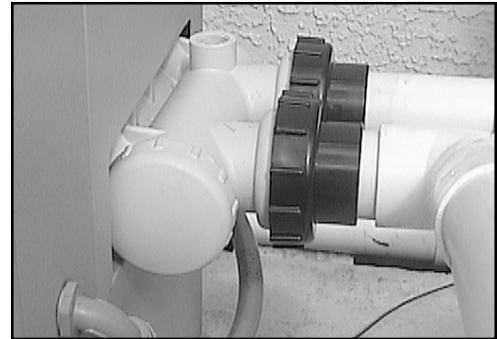

⚠ CAUTION

When lifting the heat exchanger out of the fire box, use caution so as not to damage the fire wall.



2. Remove the heat exchanger.
3. Place exchanger in an area that won't be affected by chemicals or strong detergents.
4. After spraying the exchanger with water, use a mixture of detergent and water. Pour, spray or brush on.
5. Rinse the solution off of the tubes and inspect them, repeat if necessary.

Maintenance - Reinstalling Heat Exchanger

1. Inspect fire box for damage or cracks that would allow heat to leak out into the outer cabinet and controls.

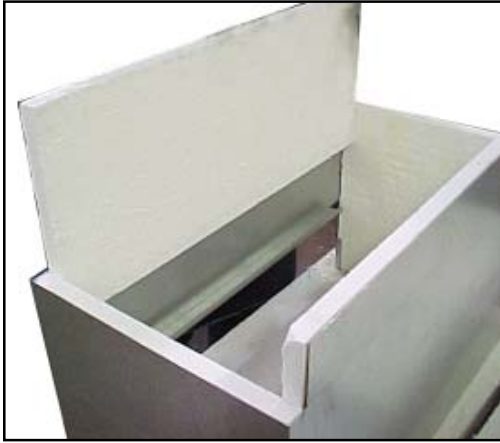

2. Remove any old sealant from fire box.
3. Apply new sealant to the fire box using a quality industrial grade R.T.V. or equivalent. The sealant must completely seal the space between the heat exchanger and fire box, so that when the heater is firing, heat does not escape to the outer cabinet.



4. Place heat exchanger into the box and push down firmly, until the heat exchanger sets solidly on the fire box.



5. Reconnect the inlet and outlet flange to the headers (use new flange gaskets), be careful not to move the heat exchanger and break the seal.

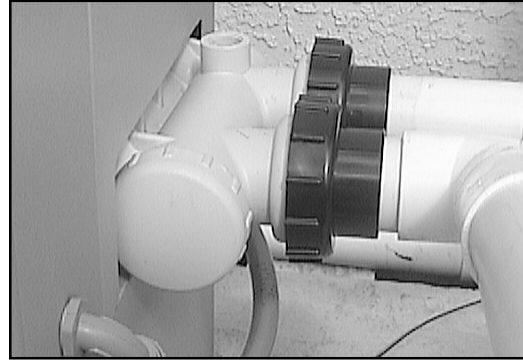

6. Reinstall baffles, flue collector, inner lid and top.



CAUTION

Do not store combustible material, gasoline and other flammable vapor and liquids in the vicinity of this or any other appliance.



Troubleshooting

DIAGNOSTIC LIGHT OPERATION

The circuit board in the MiniMax NT Series heater uses lights that are wired in sequence with the controls. The MiniMax NT Series heater still uses the same controls as the original MiniMax but this method of wiring is more helpful while troubleshooting.

Sequence wiring means that each control is wired separately from the other controls and they are independently attached to the circuit board. This is how the wiring method works to help diagnose a problem.

Power is connected to the board directly from the Transformer. So, if the Transformer is wired correctly and is being supplied with voltage, the Power light will be "ON". This is not an indication that proper voltage is being supplied by the Transformer.

When you push the "POOL/SPA" switch to either position and turn the thermostat knobs to "HOT", the voltage is transferred into the circuit board, through the Thermistor, Potentiometer and down to the Remote Control terminals. If the Thermistor and Potentiometer are working the "TSTAT" light will come "ON".

If there is a Remote Control connected to these terminals, the voltage travels to the remote switch and back to the circuit board and the "AUX" light comes "ON". If there is no Remote, there will be a jumper wire across the Remote terminals causing the "AUX" light to come "ON".

If the voltage comes across the Remote Control terminals, it will go back into the circuit board and go to the Pressure switch. If the Pump is "ON" and primed and there is enough water flow, the Pressure switch will close and the "PRESS" light will come "ON".

On the back of the circuit board, there are (3) more lights. "HIGH LIMIT", "THERMAL CUT OFF" and "PILOT VALVE". Voltage must travel to and through the High Limits, Thermal Cut Off and finally to the orange Pilot Valve wire before the Module will start to spark. And each time the voltage goes through a control, indicating that the control is working, the voltage must go back to the circuit board, where it lights the control indicator light.

With this method of wiring we can easily see which control is not working by looking at the FIRST LIGHT that is NOT LIT because we know that voltage has to pass through the control and back to the board in order for the light to come "ON". If the light is **NOT** "ON", look at that control first.

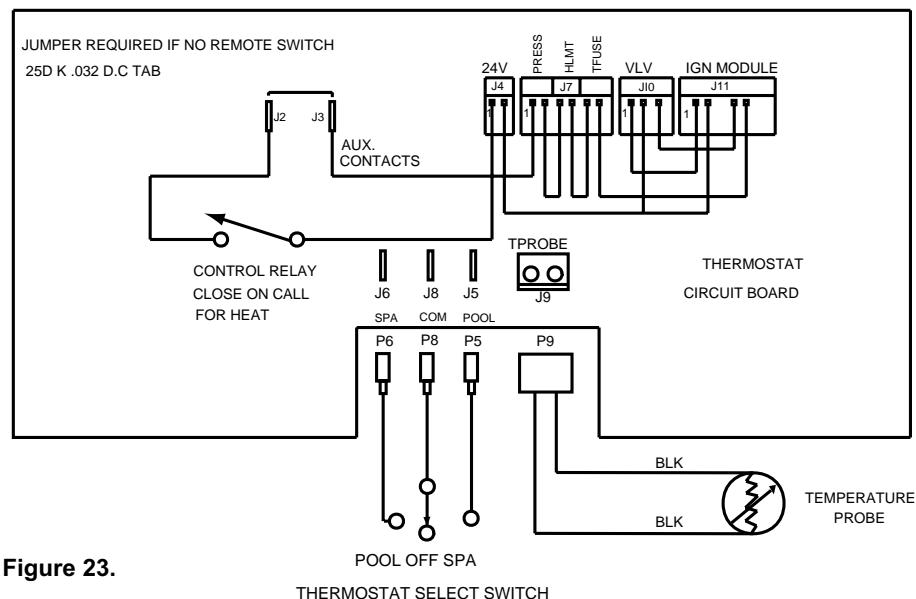

Figure 23.

Troubleshooting

1. The **POWER** Light indicates voltage to the Control Board from the Transformer. The POWER light will be ON without pushing the Pool/Spa switch as long as there is power being supplied to the transformer.
2. The **TSTAT** Light or Thermostat Light will come ON if there is voltage to the Potentiometers and they are turned to the Hot Position and the water temperature is below the hot set point.
3. The **AUX** Light or Remote Switch Light will come ON if the Remote control is operating properly and/or is attached to the back of the Control Board correctly. If the heater is not connected to a remote switch, there will be a small jumper wire attached to the Control Board to make the light come on.
4. The **PRESS** Light is attached to the Pressure Switch and will come ON if the Pump is ON and is pumping enough water to create adequate water pressure to close the contacts on the Pressure Switch.
5. The **HEAT** Light is attached to the MV (Main Valve) terminal on the Control Board. This terminal does not receive voltage until the Hot Surface Igniter (HSI) has been ON for 40 seconds. Once voltage is sent to the Gas Valve, it should open to allow gas flow to the burners that will be ignited by the HSI.
6. The **SERVICE** Light is a dual-purpose light. When there is a call for heat the Service Light will be ON during the 15-second pre-purge and the 40 second Hot Surface Igniter (HSI) heat-up period. The Service Light will be OFF during the 7 second trial for Ignition when the HEAT Light comes ON. If the burners fire and the Flame Sensor sends a signal to the Ignition Module that there is a successful ignition, the Service Light will stay OFF and the Heat light will stay ON. The Service light will also be ON if there is a problem with one or both of the High Limit Switches, the Thermal Fuse or the Valve (VAL) output on the Ignition Module.

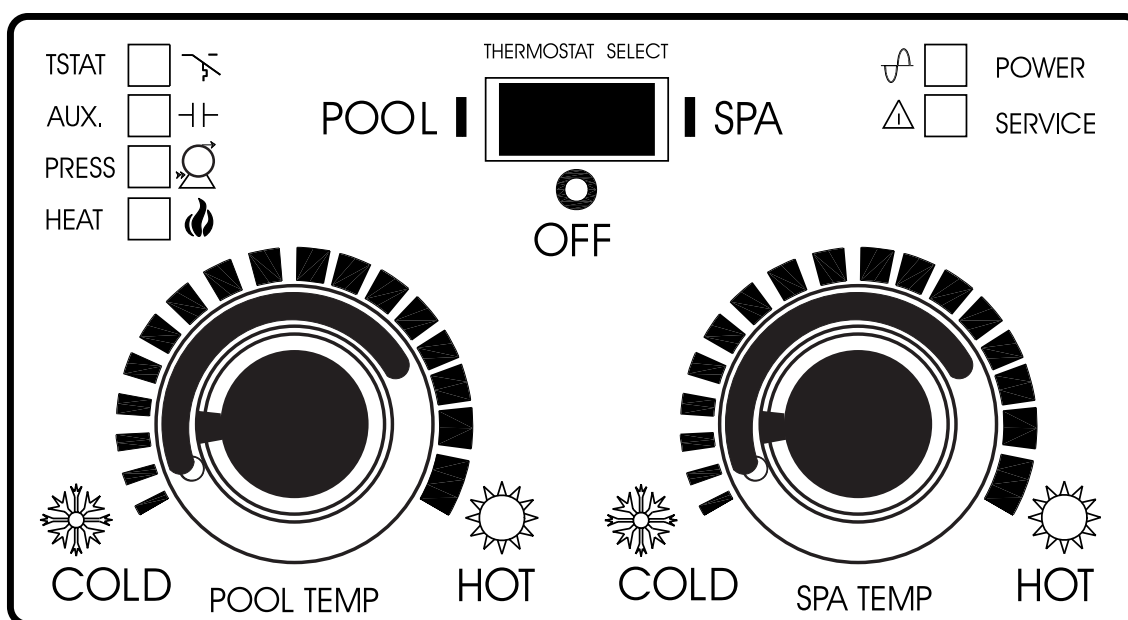

Figure 24.

Troubleshooting

MiniMax NT Series Heater Troubleshooting/Check List

1. Look at the lights, which ones are on? Review Diagnostic Lights section on previous page.
2. Check for correct voltage on Secondary side of Transformer. Should be greater than 24 VAC at Orange Wire at 24 V position on Control Board.
3. Check all wire connections on Module, Control Board, HSI, Flame Sensor and Gas Valve.
4. Check position of HSI and Flame Sensor to Burners.
5. Check for true ground and good ground connections.
6. Push the Pool/Spa switch ON to the opposite side and then the thermostat from cold to hot.
7. Make sure that the pump is running with a full prime and that the filter pressure is not too high or low.
8. Remove any Remote Control wires from the heater Control Board and replace with the jumper wire while testing.

MiniMax NT (Standard) Wire Connection

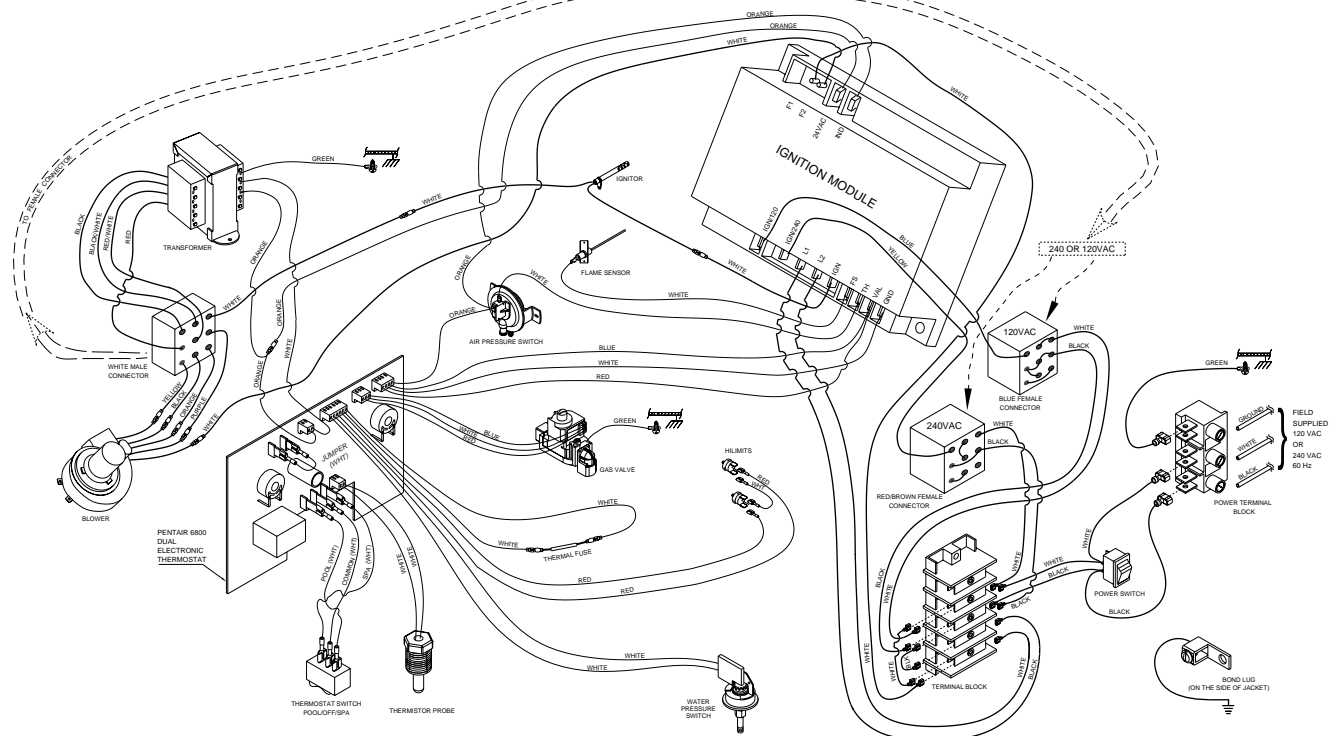

Figure 25.

Troubleshooting

DIAGNOSTIC LIGHTS SHOW "POWER" ONLY!

1. Check water temperature, if water has reached the desired temperature, the thermostat will cut off power to the module and the heater will stop firing. In this case the POWER Light would remain ON.
2. Check the voltage on the Secondary side of the Transformer. It should be greater than 24 VAC. If the voltage is less than required, the incoming voltage may be too low for the heater to operate properly, there could be a wiring short or the wrong voltage connector may be connected to the White Male Connector. Because the Power light is not a specific 24 VAC light, it will illuminate with less than 24 VAC, so even if the Power Light is ON, the voltage may not be correct.
3. The Pool/Spa switch may have inadvertently been switched Off. Even though the Pool/Spa switch does not have to be ON for the POWER Light to be ON, it does have to be pushed to either the Pool or Spa position in order to transfer voltage to the rest of the controls.
4. Make sure that the Thermostat Knobs have been turned to Hot because the voltage must pass through the thermostat (potentiometer) first before going to any other control. If the potentiometer or thermistor is not working or is disconnected from the Control Board, only the POWER Light will be ON. If you suspect that this may be the problem, first check the thermistor connections on the back of the Control Board. If this does not light the T-STAT Light, connect a known functional thermistor to the Control Board. If the light still does not come on, the Control Board is bad.

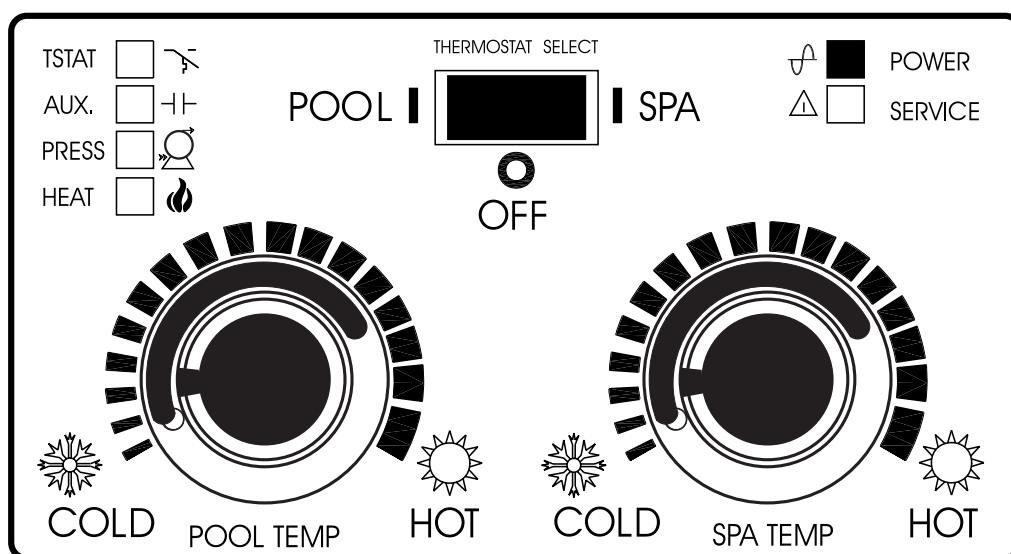

Figure 26.

Troubleshooting

POWER / T-STAT ONLY!

1. Check that jumper has not come off of EXT SWITCH terminals.
2. Remove Wires to External Switch or Remote Control System and replace with jumper. If AUX Light comes ON, the problem is in External Switch or Remote Control System.
3. Check for 24 VAC at the OUT terminal of the EXT SWITCH connection. If no voltage, Control Board is bad.

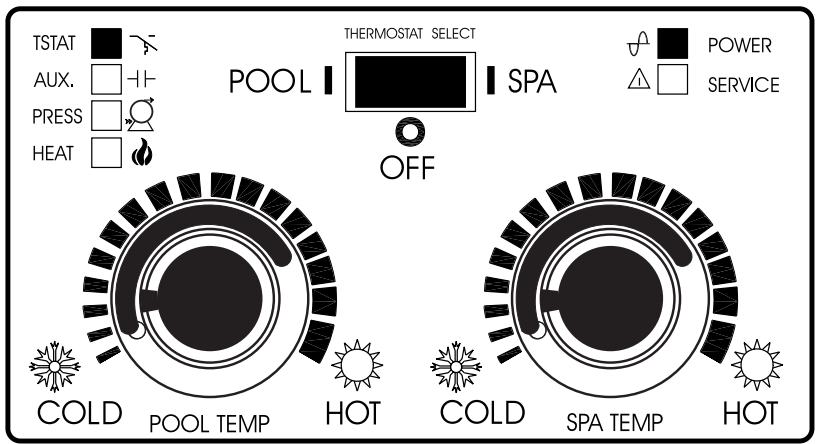

Figure 27.

2 Wire Remote

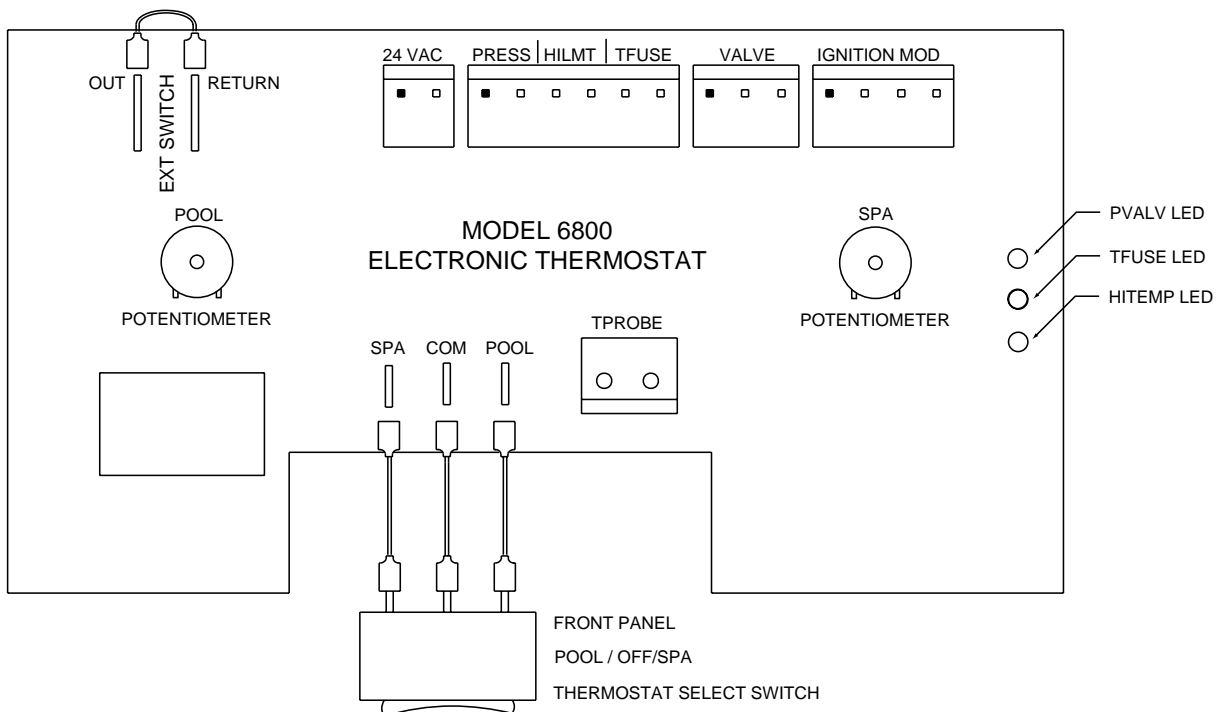

Figure 28.

Troubleshooting

POWER / T-STAT / AUX ONLY!

1. Be sure that Pump is ON and running with a full prime.
2. Is Pump Impeller clogged.*
3. Is Filter Dirty.*
4. Is Pump too small or worn out.*
 - *30 GPM is required to close the Pressure Switch. Some 2 Speed pumps will not produce 30 GPM on Low Speed.
5. Check for 24 VAC at outside White Wire on PRESS connector. If no voltage, Control Board is bad.
6. Check for 24 VAC at second White Wire on PRESS connector. If have voltage, Control Board is bad.
7. Check that wires are attached to Pressure Switch and check for 24 VAC at both terminals. If no voltage at either terminal, wire is bad. If voltage at one terminal only, Pressure Switch is clogged, out of adjustment or bad.

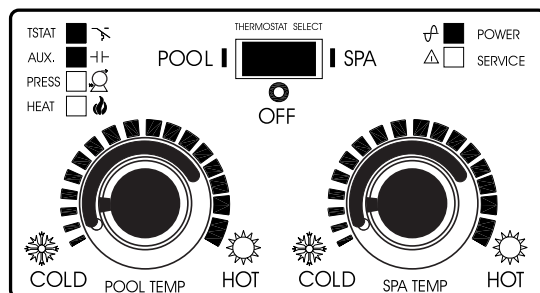

Figure 29.

MiniMax NT (Standard) Wire Connection

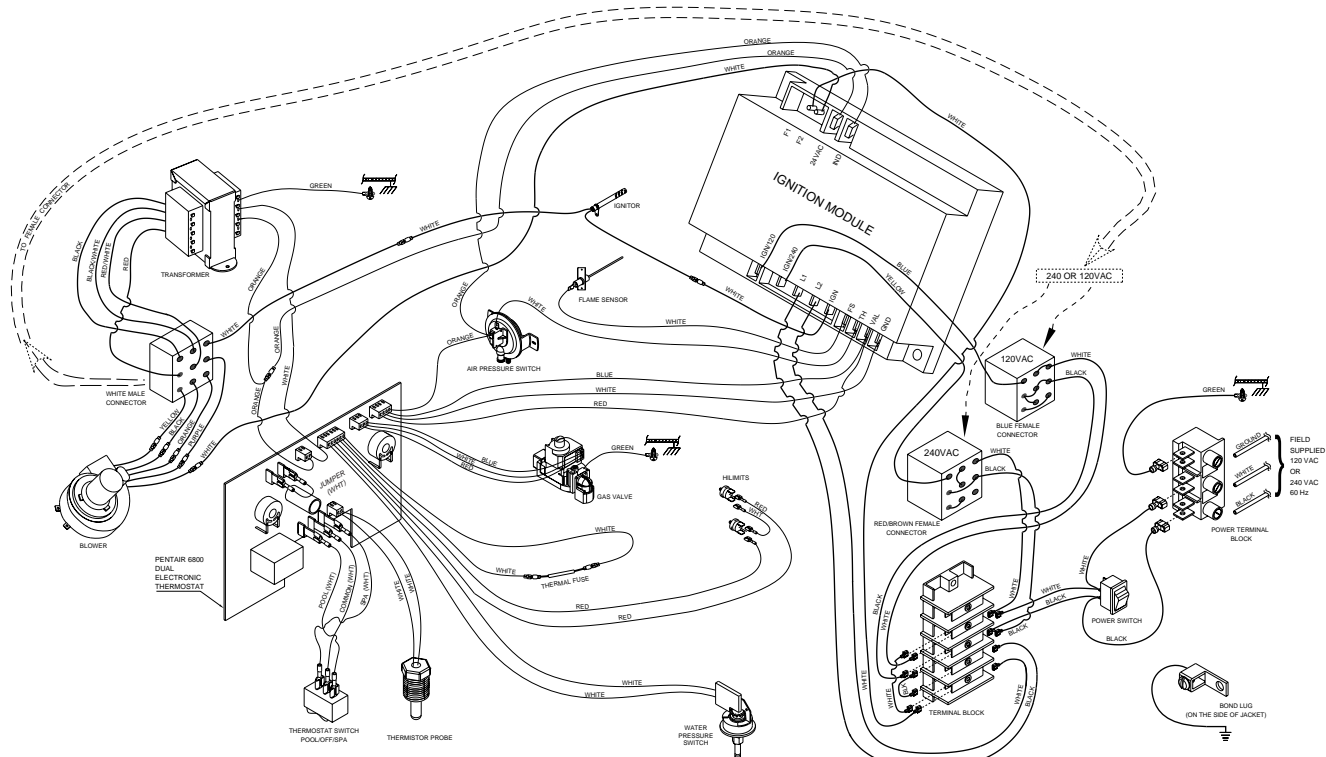

Figure 30.

Troubleshooting

POWER / T-STAT / AUX / PRESS / SERVICE Fan Not Running

1. Check the 3 lights on the back of the Control Board. These 3 lights are connected to 3 different controls in this order: #1 – High Limit, #2 – Thermal Fuse, #3 – Gas Valve.
2. If all of the lights are out, the High Limit safety switches are keeping the heater off. If the inlet water reaches 115 degrees or if the water from the heat exchanger reaches 150 degrees the heater will not fire. Check for proper water flow through heater. If water flow is correct, allow heater to cool and check continuity of the High Limit Switches. If either switch shows an open circuit when the heater is cool, replace the switch. See Figure 31.
3. If only the “High Limit” light is ‘ON’ (i.e. only one green light is on), the Thermal Fuse circuit is keeping the heater off. If there is evidence of flame roll-out at the Thermal Fuse location, it is probably burned out. Check Thermal Fuse for continuity, if good, check wiring for continuity. If Thermal Fuse is burned out, find reason for roll-out before putting heater back into service. See Figure 32.
4. If the “High Limit” and “Thermal Fuse” lights are ON (i.e. two green lights ON), Check for 24 VAC at 24 VAC terminal on Ignition Module. If none, check connections and wire back to Transformer. See Figure 33.
5. Check for 24 VAC at IND terminal on Ignition Module. If none, check connections and wire back to Control Board and then for 24 VAC at orange wire at connector at Control Board.
6. Check Fan connection on module (F1 & F2) for continuity if electric supply is 120VAC by removing plug and checking continuity across terminals. If no continuity, module is bad. If the heater electric supply is 240 VAC, leave plug in place and check for 120 volts from F1 to ground. If no voltage, module is bad. See Figure 34.
7. Check connections and wires from module and 120/240 plug connectors to fan motor. Replace fan motor if necessary.



Figure 31.



Figure 32.



Figure 33.

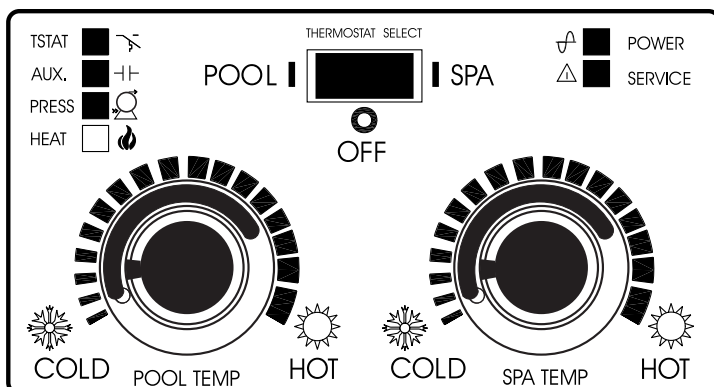

Figure 35.

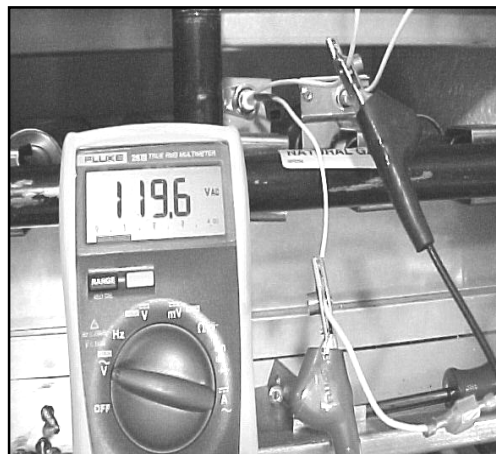
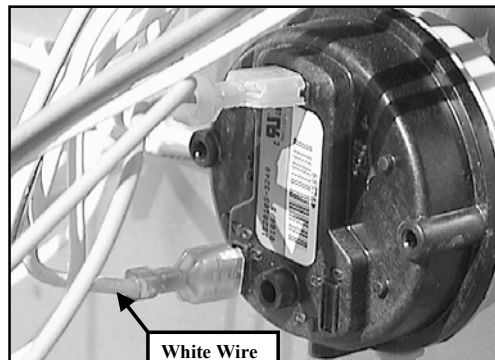

Figure 34.

Troubleshooting

POWER / T-STAT / AUX / PRESS / SERVICE Fan Running / HSI not energized and lock out occurs after 30 seconds

1. Check for 24VAC at TH terminal on Ignition Module. If none, check connections and wire and check for 24VAC at white wire terminal on Fan Vacuum Switch. If none, check Vacuum Switch operation, (see Vacuum Switch Testing section later in this manual).
2. Check for 120VAC between IGN/120 & IGN terminal on Ignition Module or 120VAC between IGN/240 & IGN terminal on Ignition Module depending on electric supply. If none, Ignition Module is bad.
3. Check for 120VAC at HSI. If none, check connections and wires. If you have 120 VAC at HSI and it's not functioning, the HSI is bad.
4. See HSI Testing section later in this manual for additional testing information.



Troubleshooting

POWER / T-STAT / AUX / PRESS / SERVICE Fan Running / HSI Energized / No Gas to Burners

1. Check the green lights on back of Control Board. If the “High Limit” and “Thermal Fuse” are ON, (i.e. only one light is OFF), there is no voltage being supplied to the Control Board from the Valve (VAL) connection on the Ignition Module. Check for 24 VAC at the “VAL” connection on the Ignition Module. If no voltage, Ignition Module is bad.

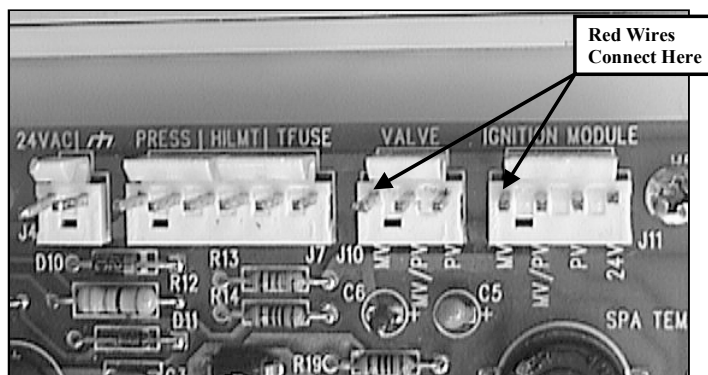

2. Check for 24 VAC at the red wire connected to the Ignition Module terminals on the Control Board. If none, check connections and red wire for continuity.
3. Check for 24 VAC at the red wire connected to the Valve connector on the Control Board. If none, Control Board is bad.
4. Check for 24 VAC at the red wire on the Gas Valve. If no voltage, check connections and red wire for continuity.
5. If there is voltage at the Gas Valve, be sure that the gas valve and all shut off valves are turned ON, that the gas line has been bled and that there is gas available.
6. If all valves are open and there is gas to the valve. Replace Gas Valve.

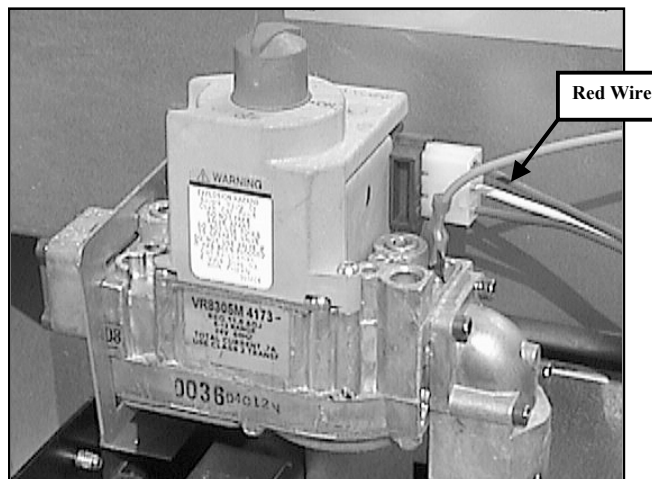

Troubleshooting

**POWER / T-STAT / AUX / PRESS
HEAT (on then off) / SERVICE (off then on)
Fan Running / HSI Energized / Burners ignite and
the go off in 7 seconds or less**

1. Check for 24 VAC at FS terminal on Ignition Module. If none, Ignition Module is bad.
2. Check for 24 VAC at Connector on Flame Sensor, if none, replace wire.
3. Check to make sure the Flame Sensor is not shorted to Ground.
4. If Flame Sensor voltage and amperage are OK, Ignition Module is bad.

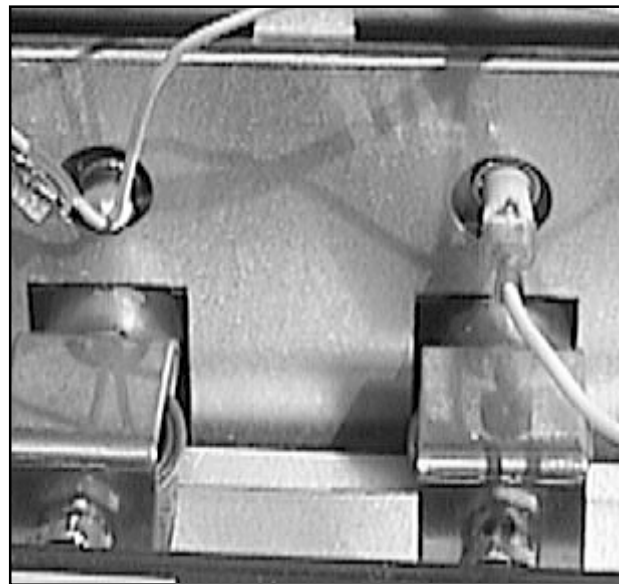

Troubleshooting

1. It is possible to bypass the 6800 Control Board and, therefore, the thermostat and safety circuits by installing a jumper from the Orange Wire on the 24V connector to the Orange Wire on the Ignition Module connector. If the heater fires, the problem is in the Control Board/Thermostat Circuit, the Thermostat Temperature Sensor (Thermistor) or the Control Circuit.
2. Each component in the Control Circuit can be checked individually at the Control Board for 24 volts in and out, but the diagnostic lights tell us if the circuit is good or bad (closed or open); therefore, it is not necessary.
3. The Thermostat Thermistor can be checked by removing the connector from the Control Board and taking an Ohm reading at the end of the connector. Compare this reading to the following conversion table to see if it is reading correctly. If it is not, replace the thermistor.

Degrees 'F'	Resistance (Ohms)	Degrees 'C'
59	15711	15
68	12492	20
77	10000	25
86	8057	30
95	6531	35
104	5326	40

Table 13.

4. If 24 VAC is not present at the orange wire on the Ignition Module connector, the Control Board is bad.

TESTING THE 6800 CONTROL BOARD CIRCUITRY

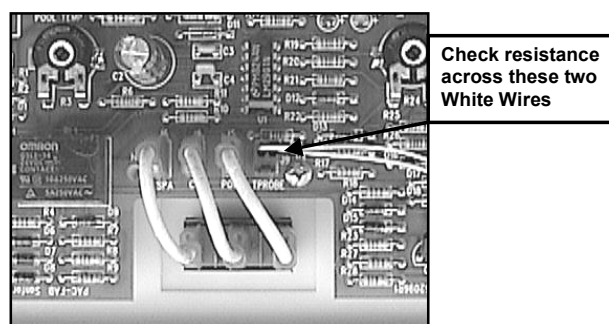
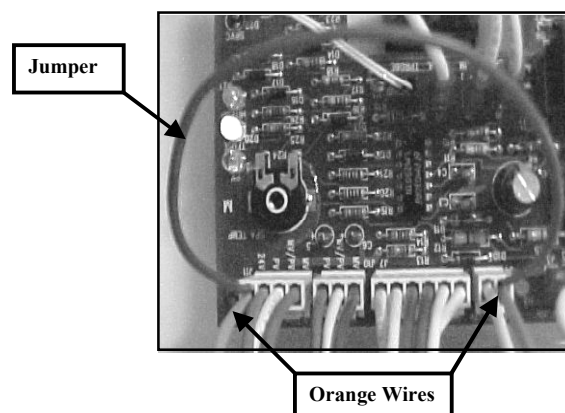

Troubleshooting

THE SERVICE LIGHT

1. The primary responsibility for the SERVICE Light is to illuminate whenever there is a problem that prevents the heater from firing (please see Diagnostic Lights explanation at the beginning of this section). However, it will also be ON during the Fan 15-second pre-purge and the 40-second Hot Surface Igniter heat up.
2. The SERVICE Light also comes ON if the burners do not continue to burn properly or if the flame goes out, if there is a bad Flame Sensor or Flame Sensor wire or if anything else causes the Ignition Module to restart the ignition sequence. So, if the SERVICE Light comes ON and heater stops firing and then the heater fires and the SERVICE Light goes out, simulating a Rapid Cycle, it can be caused by a loss of or weak signal to the Ignition Module by the Flame Sensor.
3. The SERVICE Light will come ON if the water temperature in the Inlet side of the Header reaches 115 degrees or if the water temperature at the outlet of the heat exchanger reaches 150 degrees. If the heater is cycling in this mode, the three green lights on the back of the Control Board will flash OFF and ON as the heater shuts down and refires.

NOTE

If a weak Flame Sensor signal causes the cycling, the SERVICE Light will go ON and OFF, but the High Limit Light will remain ON. If water temperature causes the cycling, the SERVICE Light will go ON and OFF AND the High Limit will go ON and OFF as well.

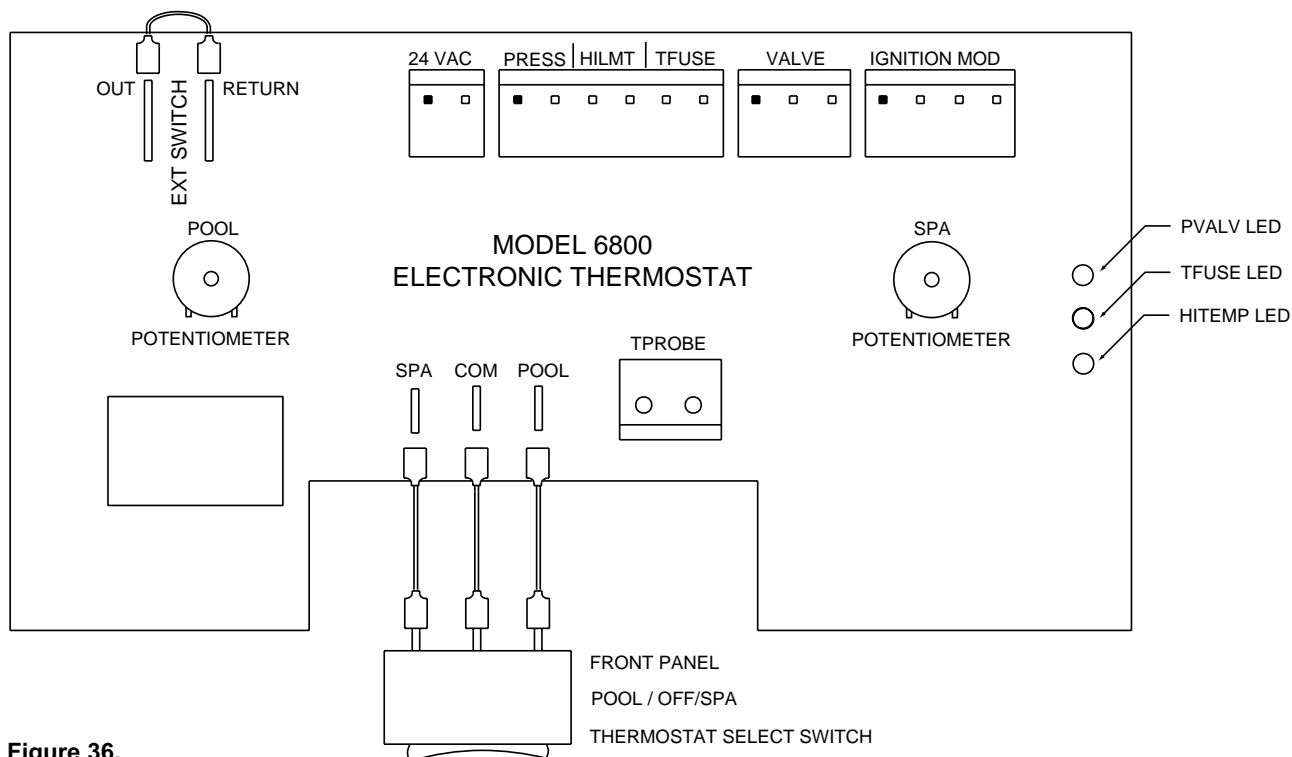
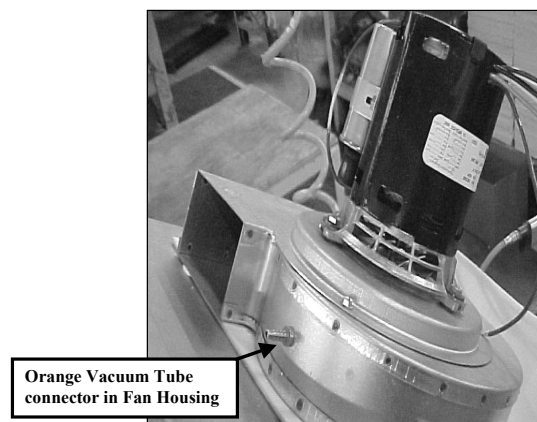
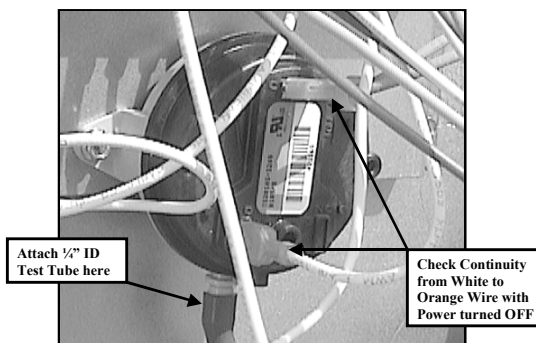

Figure 36.

Troubleshooting

TESTING THE FAN VACUUM SWITCH

1. The Fan Vacuum Switch is a normally open switch that closes on a decrease of pressure in the fan exhaust housing. It then sends 24 VAC through the white wire to the Ignition Module at the TH terminal to start the ignition sequence. Applying a vacuum to the barbed fitting where the orange tube is attached can test the switch and its circuit. To perform this test, **SHUT OFF POWER**, connect the leads of a multimeter set to Ohms to each terminal on the switch, remove orange tube from switch and, using a short piece of ¼ in. ID tube attached to the barbed fitting, draw air from the switch to see if it closes.
2. Checking to see if there is 24 VAC on the white wire terminal can also check the Fan Vacuum Switch during operation.
3. If the Fan Vacuum Switch is good but it does not close when the fan is operating and, therefore, power is not sent to the Ignition Module, the problem is in the orange tube or the connector in the Fan Housing is clogged.
4. If the Fan Vacuum Switch closes but 24 VAC is not sent to the Ignition Module, the problem is in the white wire.



Troubleshooting

TESTING THE HOT SURFACE IGNITOR (HSI)

1. The Hot Surface Igniter can be checked four different ways:
 - a. **Voltage Check:** Check for 120 VAC across two wires after 15 second pre purge time has expired.
 - b. **Amp Draw:** Check the HSI circuit for 0.5 +/- .05 amps after 15 second pre purge time has expired, (see picture).
 - c. **Continuity:** Turn OFF electric supply to heater, disconnect HSI leads and, using an Ohm setting, look for any reading greater than zero or OL.
 - d. **Visual:** Remove burner Flash Back Shield to allow visual inspection. The HSI should glow for about 47 seconds after the 15-second pre-purge cycle. It also should be located above and parallel to the burner.
2. Before replacing the HSI, be sure that the heater frame and electric circuit are properly grounded, as this will affect the performance of both the HSI and the Flame Sensor.

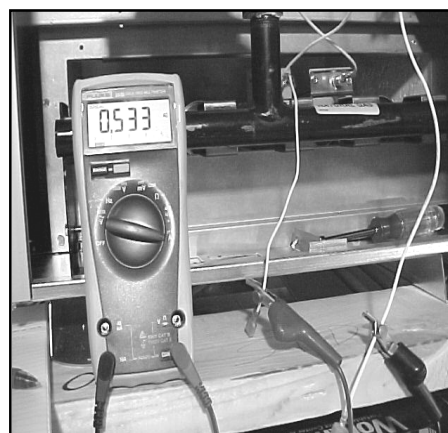

Troubleshooting

RAPID CYCLING

If the heater fires, shuts down and refires every 30-45 seconds and the Service Light comes ON and goes OFF alternately with the Heat Light, this indicates that the Inlet or Outlet High Limit Switch is sensing a temperature greater than 115° or 150° F., respectively. This is generally caused by a lack of water inside the heat exchanger, while the heater is firing.

Things To Look For:

1. The pump is worn out.
2. The pump isn't pumping enough water.
3. The pump impeller is plugged.
4. A valve on the outlet side of the heater has been closed.
5. The pump is a 2 speed that is operating on low speed.
6. Something is blocking the water flow through the heat exchanger.
7. The flow valve is defective or damaged.

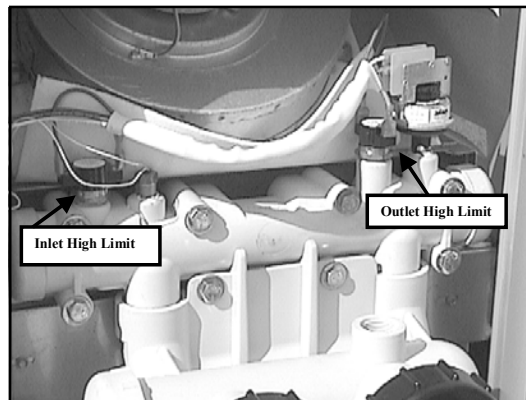

Troubleshooting

ADJUSTING FLOW VALVE

The flow valve is installed in the inlet/outlet header and allows a small portion of the water to pass through the heat exchanger when the heater is not firing. When the heater fires, as the water leaving the exchanger warms, the flow valve forces more water into the exchanger by partially closing the by-pass opening.

You can test the flow valve by removing it from the heater and placing the power element in hot water. If the power element rod extends and forces the by-pass disc to move toward the mounting plate and retracts when placed in cold water, the flow valve is OK, but if it does not move, replace the power element. The power element is copper, so water with a low pH (7.4 or lower) and or water velocity (too much flow) will cause the element to fail and the heater will cycle rapidly.

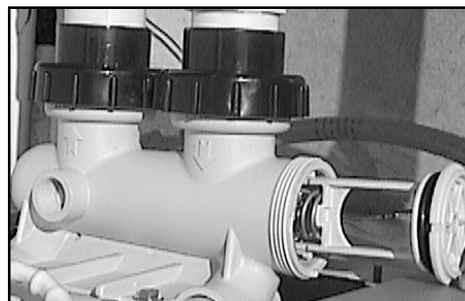

If there is not enough water in the heat exchanger to prevent the heater from cycling, the inlet/outlet header will be too hot to touch.

If you check all the water related causes of rapid cycling and do not find the problem, an electrical nuisance shut down may be causing the cycling. (wiring connections, inadequate grounding, defective or not properly aligned Flame Sensor). However, if you have followed the directions in the "BEFORE" troubleshooting section, the wiring problems should be minimal.

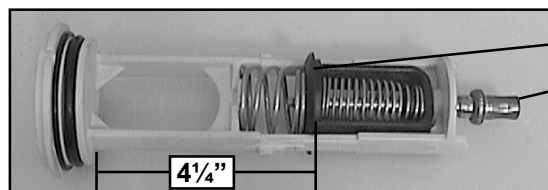

- Diverter.
- Power element.
- When replacing or adjusting the power element, use a measurement of 4 1/4" between the diverter and retention cap face.

Troubleshooting

PROPER COMPONENT VOLTAGES

Pressure switch (water)	24 volts
High limit switch (outlet)	24 volts
High limit switch (inlet)	24 volts
Thermal fuse (fusible link)	24 volts
Gas valve	24 volts
Thermostat board	24 volts
Transformer (secondary)	24 volts
Flame rectifier (signal sent back to module)	(7 micro amps) 24 volts
Hot surface igniter (only when heater firing)	120 volts
Reset switch	(depends on input voltage) 120 or 240 volts
Fan motor	(depends on input voltage) 120 or 240 volts

Troubleshooting

FENWAL IGNITION SEQUENCING MODULE



F1 – (Power output for fan circuit)

F2 – (white wire) 120 volts input – Fan circuit- when wired for 240vac

F2 – (white wire) Neutral when wired 120vac

24VAC – (orange wire marked *24 volts*) – 24 volt supply to ignition module (this wire is hot whenever the transformer is energized) - this is a direct lead

IND – (orange wire marked *IND*) – 24 volts from T-stat board when heater switch ON triggered by the completion of the safety circuit.

Troubleshooting

CONTROL WIRE TERMINAL DESIGNATION

IGN/120 – 120 volt supply for Hot Surface Igniter (*only when supply is 120 volts*)

IGN/240 – 120 volt supply for Hot Surface Igniter (*only when supply is 240 volts*)

L1 – (black wire) Line supply voltage to module (*120 volts*)

L2 – (white wire) Line supply voltage to module (*neutral only if heater supplied by 120 volts*)

IGN – (white wire) 120 volt output to Hot Surface Igniter (*only when heater firing*)

FS – (white wire) 24 volts to flame rectifier (*constant*). This is a communication wire there will be signals sent in both directions on this wire (*24vac to the sensor 7 Micro amps returning*).

TH – (white wire) 24 volts from Low Pressure Switch (*fan*)

VAL – (red and blue wires) 24 volts to open gas valve

Only the blue wire is used by the gas valve even though both have been energized.

GND – (white wire) 24 volt ground

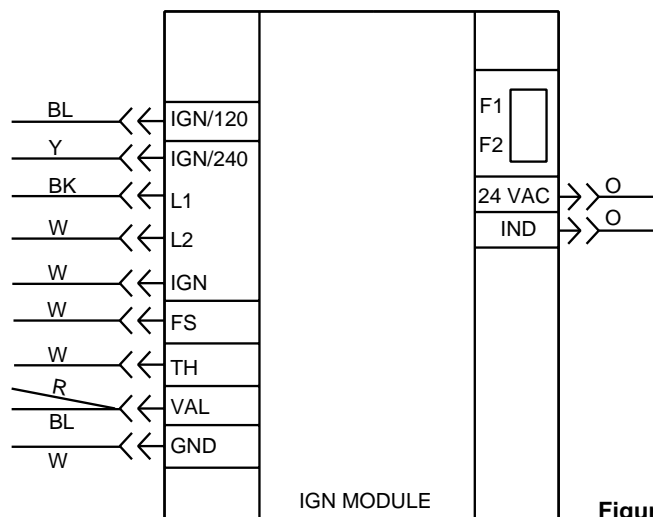

Figure 37.

STEP-BY-STEP ELECTRICAL TROUBLESHOOTING OF THE MINIMAX NT SERIES HEATER w/6800 BOARD

- Power to the heater should be configured properly at the terminal block, (for 120v the neutral lead always goes to the center lug of terminal block).
- From the terminal block the power flows through the internal shut off switch at the bottom of the J-Box. (This voltage will be the same as the supply voltage for the heater.)
- The power now is divided between the 120v and 240v female connectors; (from the factory the heater is configured for 240v to avoid damage to the transformer).
- The male connector should be plugged into the proper 120v or 240v female connector before turning on the heater. This provides the proper voltage to the transformer, fan and ignition module.
- High voltage supplied to the transformer is changed to 24vac to control the ignition process, (output voltage is relative to the input voltage and it should range from 24-29vac). Voltage readings below 24vac indicate a problem. (**NOTE:** The heater is also certified at 85% of 120v/240v too, therefore, the voltage could be as low as 22.5. However, we do NOT recommend operating the heater at that condition for a long period at all.)
- The 24vac from the transformer is supplied to the 24vac terminal on the circuit board as well as the 24vac lead on the module. This is the main power supply for the circuit board as well as the module.
- To start the ignition process, there must be a call for heat. This is provided by the thermostat circuit on the circuit board. If the thermostats are turned up and the pool/spa switch is in either the Pool or Spa position, if there is no call for heat, then check the temperature probe connection on the back of the circuit board. If the connection is good, test with a known good sensor.
- Once the thermostat circuit is completed, power is supplied to the safety circuit. The power flows as follows:
 1. From the circuit board to the pressure switch and back to the board (this will illuminate the pressure light (PRESS) on the front of the board).
 2. From the circuit board to the high limits and back to the board, (this will illuminate the high limit light (HTEMP) on the back of the board).
 3. From the circuit board to the thermal fuse and back to the board, (this will illuminate the T-fuse light (TFUSE) on the back of the board).
- When the thermostat circuit and safety circuits have been completed, 24vac is supplied to the fan-proving switch, (where it will wait for the fan to come on), and to the IND terminal on the top left of the ignition module.
- When the IND terminal is energized, the contactor between F1 and F2, (inside the Fenwal Module), closes sending power to the fan. If the fan does not come on, disconnect the wires between F1 and F2 and check for continuity through F1 and F2 with the IND terminal energized.

(continued on next page)

STEP-BY-STEP ELECTRICAL TROUBLESHOOTING OF THE MINIMAX NT SERIES HEATER w/6800 BOARD

- When the fan comes on, it transfers a low pressure (vacuum) to the fan-proving switch. This low pressure closes the fan-proving switch, which then allows 24vac to be supplied to the TH terminal on the ignition module. This starts the Ignition phase of the heater.
 1. 15 seconds of pre purge.
 2. 40 seconds of HSI heat up time.
 3. 7 seconds of flame rectification, (heater runs until no longer calling for heat).
 4. 45 seconds of post purge.
- After the 15 seconds of pre-purge, the IGN terminal on the module will be energized for 40 seconds to supply 120vac to the HSI prior to the opening of the gas valve.
- After the 40 second heat up of the HSI, 24vac is supplied from the VAL terminal on the module to the circuit board at the connection labeled “Module”. This is done to activate the heat light (HEAT) on the front of the board as well as the PV light on the back of the board. The service light will go out when the heat light comes on.
- 24vac is then supplied from the VLV terminal on the circuit board to energize the gas valve using the blue wire.
- Once the gas valve is open, the gas is exposed to the heat generated by the HSI and ignites.
- From the time the ignition module is energized, (at the 24vac terminal), the flame sensor, (NOT available for LN heater), is supplied with 24vac as well. Now that there is a flame between the burner tray and the flame sensor, that same 24vac signal has a path to ground. This completes the flame rectification circuit and discontinues the power supply to the hot surface igniter. (**NOTE:** If the flame rectification circuit is compromised, the heater will shut down and attempt the ignition process again.)

NOTE: The heater will shut down under the following conditions:

1. Outlet high limit opens up due to pool or spa water flow temperature.
2. Inlet high limit opens up due to pool or spa water temperatures in excess of 115° F.
3. Thermal fuse opens up due to roll out condition.
4. Fan proving switch does not close or open up during operation due to an obstruction of venting or use of excessive vent piping.
5. Flame rectification is lost due to insufficient gas supply, improperly positioned or defective flame sensor.

Glossary

1. **BURNER:** A device for the final conveyance of gas, or a mixture of gas and air, to the combustion zone.
2. **BUTANE:** A hydrocarbon fuel gas heavier than methane and propane and a major constituent of liquefied petroleum gases.
3. **CIRCUIT BOARD:** Interprets signals from potentiometers and thermistor.
4. **COMBUSTION:** The rapid oxidation of fuel gases accompanied by the production of heat or heat and light.
5. **COMBUSTION AIR:** Air supplied in an appliance specifically for the combustion of a fuel gas.
6. **CUBIC FOOT OF GAS:** (Standard Conditions). The amount of gas which will occupy 1 cubic foot when at a temperature of 60° F. and under a pressure equivalent to that of 30 inches of mercury.
7. **DRAFT HOOD:** (Draft Diverter). A device built into an appliance, or made part of a vent connector from an appliance, which is designed to: (1) assure the ready escape of the products of combustion in the event of no draft, backdraft, or stoppage beyond the draft hood; (2) prevent backdraft from entering the appliance; and (3) neutralize the effect of stack action of a chimney or gas vent upon the operation of the appliance.
8. **DOWNDRAFT:** Excessive high air pressure existing at the outlet of chimney or stack which tends to make gases flow downward in the stack.
9. **FLASHBACK:** An undesirable flame characteristic in which burner flames strike back into a burner to burn there or to create a pop after the gas supply has been turned off.
10. **FLUE GASES, FLUE PRODUCTS:** Products of combustion and excess air in appliance flues or heat exchangers before the draft hood.
11. **GAS VALVE:** A device that allows gas to flow from the gas supply line into the pilot assembly and into the main burners after receiving voltage from the module.
12. **HEAT EXCHANGER:** Any device for transferring heat from one fluid to another.
13. **HIGH LIMITS:** Devices installed into the outlet side of the inlet/outlet header, designed to shut heater off when water temperature reaches 150° F.
14. **LIQUEFIED PETROLEUM GASES:** The terms "Liquefied Petroleum Gases" "LPG" and "LP Gas" mean and include any fuel gas which is composed predominantly of any of the following hydrocarbons, or mixtures of them: propane, propylene, normal butane or isobutane and butylenes.
15. **MANIFOLD:** The conduit of an appliance which supplies gas to the individual burners.
16. **MODULE:** Device that sends signals to the pilot ignitor and gas valve. The module starts the pilot spark and main burner sequence.
17. **NATURAL GAS:** Any gas found in the earth, as opposed to gases which are manufactured.
18. **ORIFICE:** An opening in an orifice cap (hood), orifice spud or other device through which gas is discharged, and whereby the flow of gas is limited and/or controlled.
19. **POTENTIOMETER:** Registers desired temperature setting on circuit board.
20. **PRESSURE SWITCH:** A normally open switch that closes with adequate water pressure.
21. **PRIMARY AIR:** The combustion air introduced into a burner which mixes with the gas before it reaches the port. Usually expressed as a percentage of air required for complete combustion of the gas.
22. **PROPANE:** A hydrocarbon gas heavier than methane but lighter than butane. It is used as a fuel gas alone, mixed with air or as a major constituent of liquefied petroleum gases.
23. **SOOT:** A black substance, mostly consisting of small particles of carbon, which can result from incomplete combustion and appear as smoke.
24. **TRANSFORMER:** A coil device that changes high voltage to low voltage.
25. **THERM:** A unit of heat energy equal to 100,000 Btu.
26. **THERMAL CUT OFF:** A one shot soldered pill type fuse that melts and interrupts power to the controls if the temperature becomes too high in the gas valve area.
27. **THERMISTOR:** Installed in the inlet/outlet header, senses water temperature and tells circuit board when to shut heater off.
28. **VENT:** A device, such as a pipe, to transmit flue products from an appliance to the outdoors. This term also is used to designate a small hole or opening for the escape of a fluid (such as in a gas control).
29. **WATER COLUMN:** Abbreviated as W.C. A unit used for expressing pressure.

MINIMAX NT SERIES HEATER (Non-ASME Shown)
 (Dual Voltage w/6800 Controller)

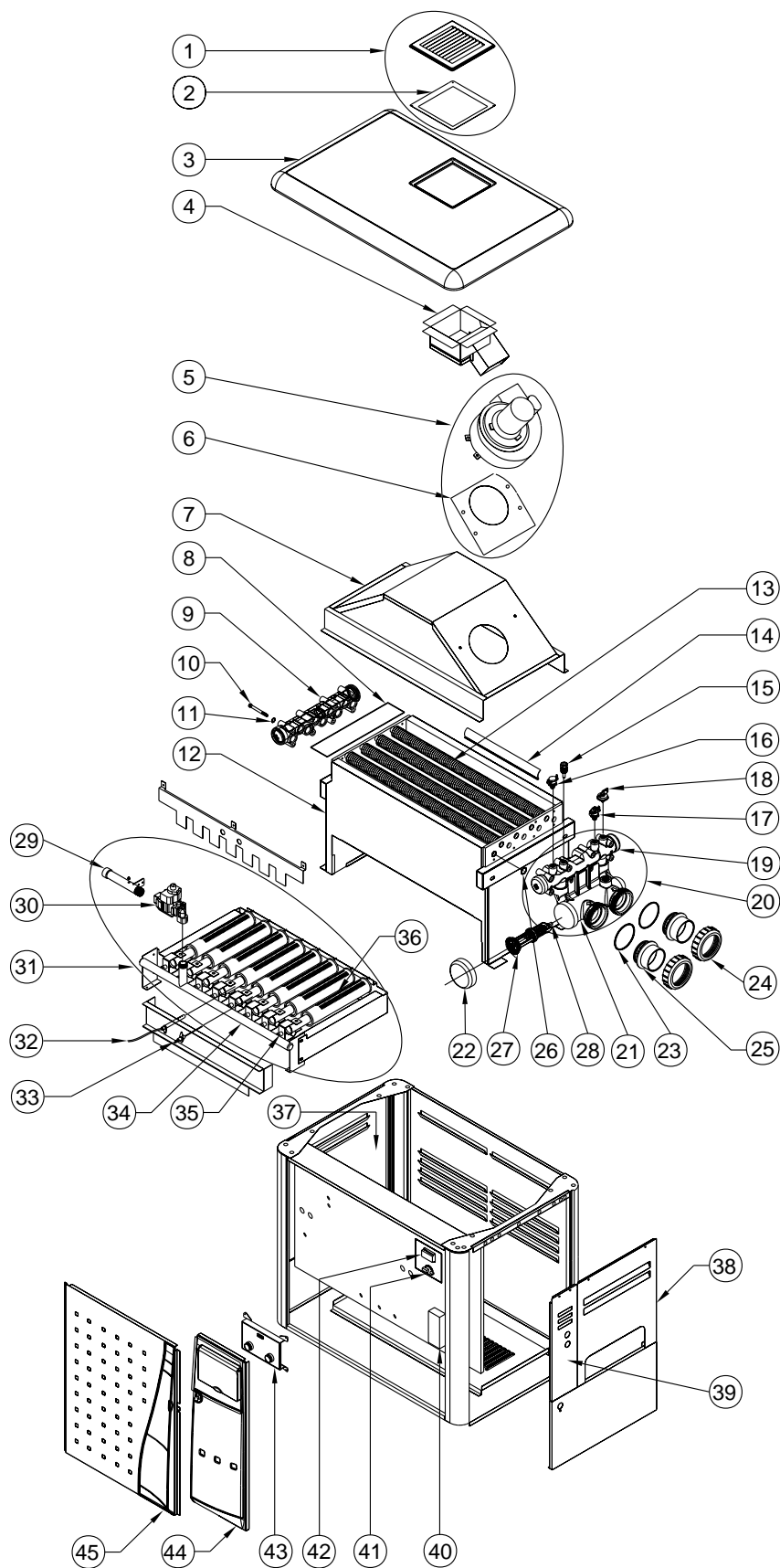

MiniMax NT STD w/6800 Controller Replacement Parts						
Item	Description	Quantity	200	250	300	400
1	Exhaust Grill w/Gasket	1	472352			
2	Gasket, Exhaust Grill	1	471701			
3	Top Cover w/Posts	1	472353	472354	472355	472356
4	Exhaust Assembly	1	472373	472376	472373	
5	Blower w/Gasket	1	472361	472362		472374
6	Gasket, Blower	1	471610			
7	Flue Collector	1	472008	472007	472006	472005
8	Insulation, Header/Hi-Limit	1	472270			
9	Return Header Assembly	1	471991			
10	Bolt, Heat Exchanger	16	471622			
11	Washer, Heat Exchanger	16	072184			
12	Fire Box Assembly	1	471904	471835	471922	472332
13	Heat Exchanger w/Headers	1	471910	471785	471928	471838
	Heat Exchanger w/o Headers	1	471933	471934	471935	471936
14	Baffle, Heat Exchanger	8 / 16 (200,250,300/400)	471642	471641	471896	471640
15	Thermistor Probe	1	471566			
16	Hi-Limit Thermostat - 115° F.	1	471587			
17	Hi-Limit Thermostat - 150° F.	1	471694			
18	Water Pressure Switch	1	472125			
19	In/Out Top Sub-Header Assembly	1	472363			
20	In/Out Main Header Assembly	1	471992			
21	In/Out Bottom Sub-Header	1	472364			
22	Cap, In/Out Bottom Sub-Header	1	471420			
23	O-Ring, Adapter	2	274494			
24	Adapter, Bulkhead Ring	2	274440			
25	Adapter, Bulkhead, 2"	2	471441			
26	Gasket, Fin Tube, Seal	18	070951			
27	Flow Valve Assembly	1	471750			
28	Power Element, Flow Valve	1	472330			
29	Sub-Gas Manifold w/Plug	1	472365			
30	Gas Valve - Natural Gas	1	471601			
	Gas Valve - Propane		471671			
31	Burner Tray Assembly, Natural Gas	1	472042	472037	472033	472028
	Burner Tray Assembly, Propane		471907	471913	471925	471931
32	Igniter	1	471602			
33	Flame Sensor	1	471603			
34	Gas Manifold w/Orifices, Natural, 0-2000'	1	472023	472022	472021	472020
	Gas Manifold w/Orifices, Propane, 0-2000'		472027	472026	472025	472024
35	Orifices, Natural, 0-2000'	4 / 5 / 6 / 8 (200/250/300/400)	073727			
	Orifices, Propane, 0-2000'		073728			
36	Burner	2 / 3 / 4 / 6 (200/250/300/400)	070230			
	Burner w/Bracket		471970			
37	Jacket, Upper Panel, Left	1	471575			
38	Jacket, Upper Panel, Right	1	471576			
39	Jacket, Upper Sub-Plate	2	471767			
40	Junction Box Assembly	1	472015			
41	Air Pressure Switch, 0-4000'	1	472311	472313	472314	472315
42	Module, Ignition Control	1	472080			
43	Temperature Controller Assembly	1	472086			
44	Right Door Assembly with Controller	1	472087			
	Right Door Assembly W/O Controller	1	472372			
45	Left Door Assembly	1	471900	472318	471918	471726
NA	Thermal Cut-off (Not Shown)	1	075173			
NA	Transformer, 40 VA (Not Shown)	1	471571			
NA	Wire Harness Assembly (Not Shown)	1	472375			
NA	Indoor Vent Adaptor (Not Shown)	1	460506(4") ; 460507(5")			
NA	Non-Combustible Base (Not Shown)	1	471390	471391	471393	471394

Note: Parts for ASME and high altitude are not listed above, please contact our Customer Service Department for details.

MINIMAX NT LOW NO_x HEATER *(Non-ASME Shown)*

(Dual Voltage w/6800 Controller)

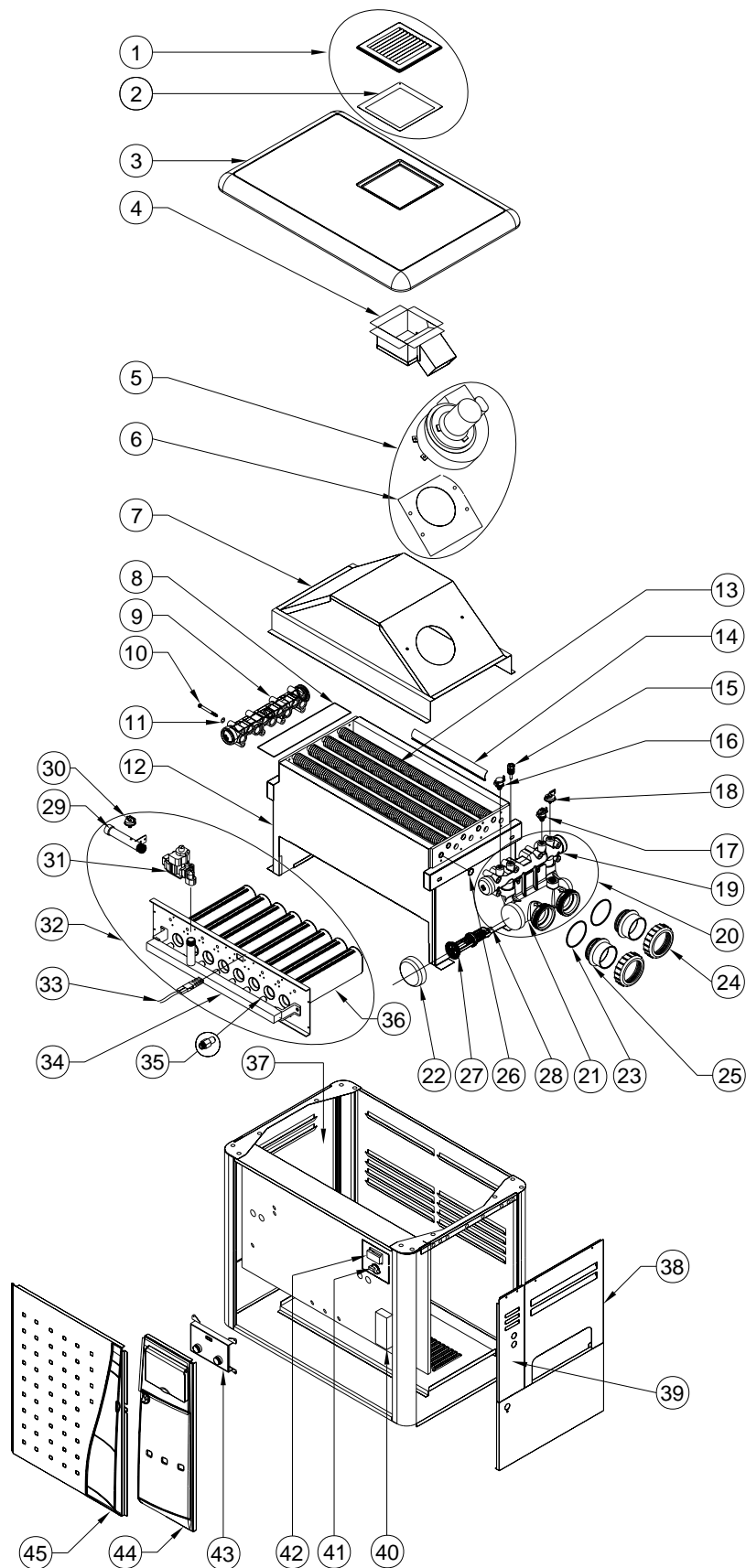

MiniMax NT LN w/6800 Controller Replacement Parts

Item	Description	Quantity	200	250	300	400
1	Exhaust Grill w/Gasket	1	472352			
2	Gasket, Exhaust Grill	1	471701			
3	Top Cover w/Posts	1	472353	472354	472355	472356
4	Exhaust Assembly	1	472357	472359	472357	472373
5	Blower w/Gasket	1	472361	472362		
6	Gasket, Blower	1	471610			
7	Flue Collector	1	472008	472007	472006	472005
8	Insulation, Header/Hi-Limit	1	472270			
9	Return Header Assembly	1	471991			
10	Bolt, Heat Exchanger	16	471622			
11	Washer, Heat Exchanger	16	072184			
12	Fire Box Assembly	1	471904	471835	471922	472332
13	Heat Exchanger w/Headers	1	471910	471785	471928	471838
	Heat Exchanger w/o Headers	1	471933	471934	471935	471936
14	Baffle, Heat Exchanger	8 / 16 (200,250,300/400)	471642	471641	471896	471640
15	Thermistor Probe	1	471566			
16	Hi-Limit Thermostat - 115° F.	1	471587			
17	Hi-Limit Thermostat - 150° F.	1	471694			
18	Water Pressure Switch	1	472125			
19	In/Out Top Sub-Header Assembly	1	472363			
20	In/Out Main Header Assembly	1	471992			
21	In/Out Bottom Sub-Header	1	472364			
22	Cap, In/Out Bottom Sub-Header	1	471420			
23	O-Ring, Adapter	2	274494			
24	Adapter, Bulkhead Ring	2	274440			
25	Adapter, Bulkhead, 2"	2	471441			
26	Gasket, Fin Tube, Seal	18	070951			
27	Flow Valve Assembly	1	471750			
28	Power Element, Flow Valve	1	472330			
29	Sub-Gas Manifold	1	471597			
30	Gas Pressure Switch	1	472083			
31	Gas Valve - Natural Gas	1	471601			
32	Burner Tray Assembly	1	471905	472016	471923	471981
33	Igniter	1	471696			
34	Gas Manifold w/Orifices, 0-4000'	1	472004	472003	472002	472001
35	Gas Orifice, 0-4000'	4 / 5 / 6 / 8 (200/250/300/400)	471984			
36	Burner	4 / 5 / 6 / 8 (200/250/300/400)	471668			
37	Jacket, Upper Panel, Left	1	471575			
38	Jacket, Upper Panel, Right	1	471576			
39	Jacket, Upper Sub-Plate	2	471767			
40	Junction Box Assembly	1	472015			
41	Air Pressure Switch, 0-4000'	1	472311	472313	471743	471897
42	Module, Ignition Control	1	472080			
43	Temperature Controller Assembly	1	472086			
44	Right Door Assembly with Controller	1	472087			
	Right Door Assembly W/O Controller	1	472372			
45	Left Door Assembly	1	471900	472318	471918	471726
NA	Thermal Cut-off (Not Shown)	1	075173			
NA	Transformer, 40 VA (Not Shown)	1	471571			
NA	Wire Harness Assembly (Not Shown)	1	472375			
NA	Indoor Vent Adaptor (Not Shown)	1	460506(4") ; 460507(5")			
NA	Non-Combustible Base (Not Shown)	1	471390	471391	471393	471394

Note: Parts for ASME and high altitude (above 4000') are not listed above, please contact our Customer Service Department for details.

SAVE THESE INSTRUCTIONS.

Pentair Pool Products, Inc.

1620 Hawkins Ave., Sanford, NC 27330 • (919) 774-4151
10951 W. Los Angeles Ave., Moorpark, CA 93021 • (805) 523-2400



Pentair
Pool Products[®]

*Because **reliability** matters most*