

# Panasonic

## Operating Instructions

Instrucciones de Uso  
Mode d'emploi

---

### Household Massage Lounger Sillón de Masaje Doméstico Fauteuil vibromasseur

---

Model No./Nº de Modelo/Nº de modèle **EP1082**

---

---

---

**English** 1

**Español** S1

**Français** F1



Before operating this unit, please read these instructions completely.

Antes de utilizar esta unidad, lea completamente estas instrucciones y guárdelas para referencia futura.

Avant d'utiliser cet appareil, nous vous recommandons de lire l'ensemble de ces instructions et de les ranger dans un endroit accessible pour une consultation ultérieure.

# IMPORTANT SAFETY INSTRUCTIONS

Basic precautions should always be followed when using an electrical unit, including the following.

Please ensure that you read all instructions before using the Household Massage Lounger.

## **DANGER** – To reduce the risk of electric shock:

1. Always unplug this unit from the electrical outlet immediately after using and before cleaning.

## **WARNING** – To reduce the risk of burns, fire, electric shock, or injury to persons:

1. Always insert the power plug all the way into the outlet to reduce the risk of short-circuit and fire.
2. The unit should never be left unattended when plugged in. Always unplug the unit when not in use.
3. The unit is not to be used by people who cannot move or communicate on their own.
4. Only use the unit for the purpose described in these instructions.
5. Do not stand on the unit.
6. Do not use any accessories other than those recommended by the manufacturer.
7. Always return the seat to the upright position. Keep children away from the unit.
8. Never operate the unit if it has a damaged power cord or plug. Return the unit to the nearest authorized service center if it is not working properly, if it has been dropped or damaged, or if it has been immersed in water.
9. Keep power cords away from heated surfaces. Do not carry the unit by the power cord.
10. Never block the air openings during operation and make sure that all air openings are kept free of lint and hair, etc. Do not drop or insert anything into any of the openings of the unit.
11. Do not use the unit on top of heating appliances, such as electric carpets, etc. Do not operate the unit under blanket or pillow. Excessive heating can occur and cause fire, electric shock, or injury to persons.
12. Do not use the unit in bathrooms or other damp or humid places as this may cause electric shock or cause the unit to malfunction. Do not spill water, etc. onto the controller.
13. Do not use the unit outdoors.
14. Do not use or operate where aerosol spray products are being used or where oxygen is being administered.
15. When unplugging the unit, turn off all controls before removing the plug from power outlet. Do not use the unit with a transformer as this may lead to malfunction or electric shock.
16. Connect this unit to a properly grounded outlet only. See Grounding Instructions.

## **SAVE THESE INSTRUCTIONS**

# SAFETY PRECAUTIONS

## WARNING: To avoid the risk of injury:

1. Persons with any of the conditions listed below or who are undergoing medical treatment or suffer from medical conditions should consult with their physicians before using the unit:
  - a) Pregnant women, people who are ill, in poor physical shape.
  - b) People suffering from back, neck, shoulder, or hip pain.
  - c) People who have a pacemaker, defibrillator, or other personal medical devices prone to electronic interference.
  - d) People suffering from heart disease.
  - e) People who are prohibited from receiving massage by a physician due to thrombosis or aneurism, acute varicose veins, or other circulatory disorders.
  - f) People with irregular curvatures of the spine.
2. This unit should not be used by children. Remove the key when not in use and store out of reach of children.
3. Sit down slowly after checking the position of the massage heads. Never put any part of your body between the massage heads as the squeezing action of the massage heads may cause injury. Never put your fingers or feet in the gap between the backrest and seat, the backrest and the armrest, or the seat and cover under the armrest.
4. Do not use the unit against bare skin. While thin clothing may increase effectiveness, exposing the skin directly to the massager may irritate the skin.  
Do not use the unit while wearing anything hard on your head like a hair accessory, etc. Do not use the unit for massaging the head, abdomen, front neck, elbows or knees.  
Do not use excessively strong massage action on the back of the neck.
5. When using the massager, use the Neck Roller Position button to adjust the massage heads to the correct position. You can adjust the shoulder position in this way in the pre-programs and Rolling in the manual operation.  
Failure to align the shoulder position correctly can lead to injury.
6. Do not stretch the back muscles for more than approximately 15 minutes at a time. To avoid overstretching the muscles which may result in discomfort, do not use the unit for more than 5 minutes when first using it. You can gradually increase the duration and strength of the massage as you become used to it.  
Do not massage any one point for more than 5 minutes at a time.  
Excessive massaging can overstimulate the muscles and nerves and result in an adverse effect.  
To prevent excessive massaging, do not use the massager for more than a total of 15 minutes each session.  
After approximately 15 minutes, the massage heads will be retracted and stop moving.  
The back cushion can be removed if you want to experience a stronger back massage. Exercise extreme care when you use this mode in order to avoid back pain or injury. Use only for short periods of time (no more than 15 minutes). Reinstall the back cushion if you want to restore to normal massage intensity.
7. While using the massager, if you start feeling sick or if the massage seems painful, stop using it immediately. While using the massager, if the pressure seems too strong, the movement of the massage heads can be stopped at any time by pressing the Quick Stop button.
8. Do not go to sleep while using the unit. Do not use the unit after drinking alcohol.
9. When the seat back is in a reclined position, do not sit on it or sit with your legs resting on the headrest.
10. Do not allow children or pets to play on or around the unit, especially during operation.
11. Do not unplug the unit or turn it off during operation. Unplug the unit immediately if there is a power outage.
12. Be sure to start on the gentle massage program if using the massager for the first time. The shiatsu massage is stronger and should be enjoyed after one has gotten accustomed to the chair.
13. Do not allow children to play on this mechanized furniture or operate the mechanism. Always leave in an upright and closed position. Keep hands and feet clear of mechanism. Only the occupant should operate it.
14. Always raise the back cushion to check that the fabric of the unit itself has not been ripped before using the unit. Please also check other areas to ensure that the fabric has not been ripped. No matter how small the rip, if you find one then immediately stop using the unit, unplug the power cord and have the unit repaired at an authorized service center.

# OPERATING PRECAUTIONS

## **WARNING: To avoid damaging the chair, follow these precautions:**

1. The chair is designed for a maximum user weight of 264 lbs (120 kg). Exceeding the maximum weight may cause permanent damage to the massage mechanism and/or other components of the unit. Any such damage is deemed to be user abuse and is not covered under the Limited Warranty.
2. Do not sit on or drop the controller. Do not pull the controller cord or the power cord. Be careful not to catch the cord of the controller between the armrest and the chair back.
3. Do not treat the chair roughly, turn the chair on its side, turn the chair over or stand on it.
4. Do not treat the covering roughly.
  - Keep sharp or pointed objects away from the covering of the chair. Be careful not to drop lit ashes, lit cigarettes or matches on the chair.
  - Exposure to direct sunlight can cause fading or a change in color of the covering.
5. If the massager functions abnormally, immediately turn off the power and have the massager checked by an authorized service center.
6. Do not repeatedly operate any switch at short intervals. Such action may cause the switch to malfunction.
7. Some noise may be heard coming from the massager while in use. This is due to the structure of the massager and is normal.
8. Make sure there are no obstacles behind the chair before reclining it. The chair can be reclined to a maximum angle of 170°. If the back hits a wall or pillar, the chair may malfunction. Be sure to have ample space behind the chair. Recline the chair slowly in order to avoid contact with an obstacle.
9. When excessive pressure is applied to the massage heads, they may stop moving for safety. When moving the heads up from the lowered position, one's body weight may stop the heads' movement. In such a case, slightly raise your body and allow the massage heads to move up.
10. After each massage, slide the power switch, which is located on the right side of the chair, to the "off" position and turn its lock switch to the "lock" position.
11. Do not sit on the chair with wet body or hair.
12. The unit must not be used in "wet rooms" (sauna, swimming pool) or outdoors.
13. Do not attempt to open or disassemble any part of the unit. Only use an authorized Panasonic servicer to fix your unit.

# GROUNDING INSTRUCTIONS

This product must be grounded. If it should malfunction or break down, grounding provides a path of least resistance for electric current to reduce the risk of electric shock. This product is equipped with a cord having an equipment-grounding conductor and a grounding plug. The plug must be plugged into an appropriate outlet that is properly installed and grounded in accordance with all local codes and ordinances.

## DANGER

Improper connection of the equipment-grounding conductor can result in a risk of electric shock. Check with a qualified electrician or serviceman if you are in doubt as to whether the product is properly grounded. Do not modify the plug provided with the product – if it will not fit the outlet, have a proper outlet installed by a qualified electrician.

This product is for use on a nominal 120-volt circuit and has a grounding plug that looks like the plug illustrated in Figure A. Make sure that the product is connected to an outlet having the same configuration as the plug. No adapter should be used with this product.

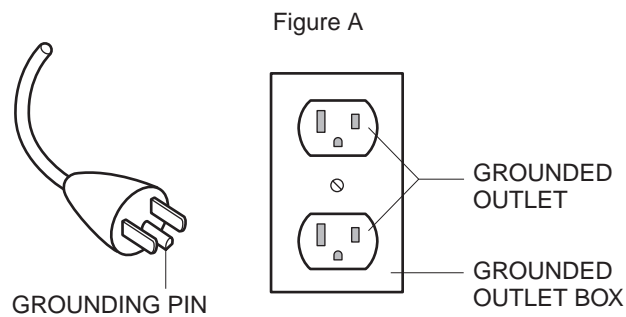

# PART NAMES AND FUNCTIONS

## MASSAGE LOUNGER

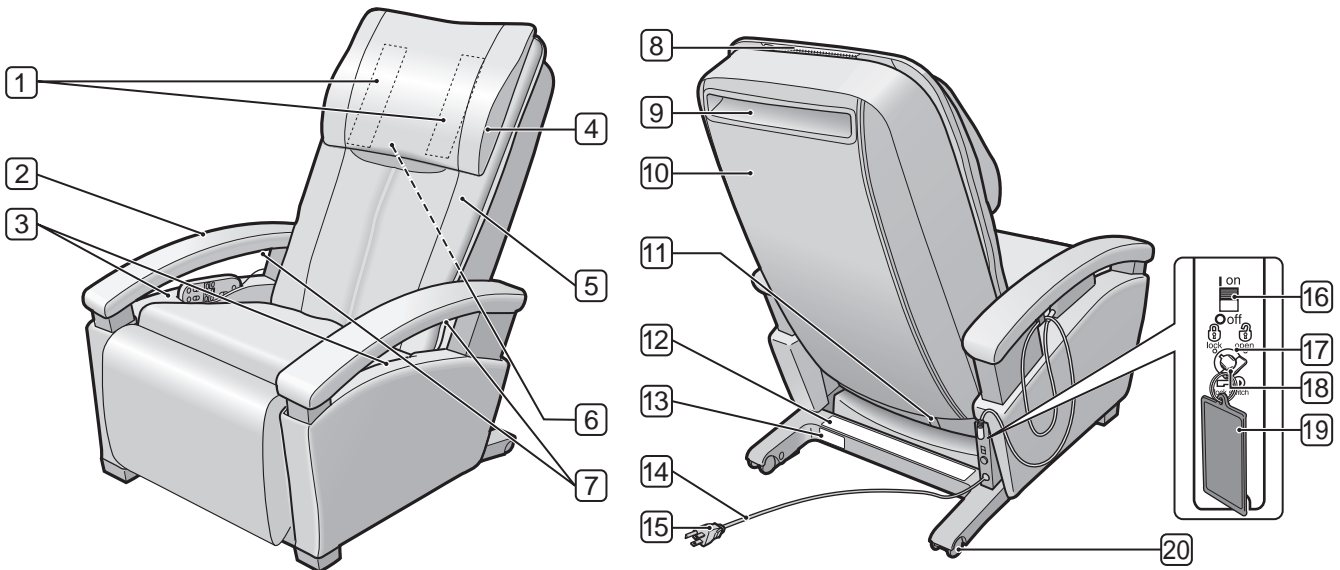

**1 Pillow Velcroes**

**2 Armrest**

**3 Controller Holder**

- On both the left and right side.

**4 Pillow**

- For use when watching TV or just relaxing.
- The pillow has a height adjustment. (See Page 10)
- The pillow is detachable, and can also be flipped over.

**5 Back Cushion**

**6 Retracted Position of Massage Heads**

- The massage heads are normally retracted to the left and right in the upper part of the backrest.

**7 Velcro for securing the controller cord**

**8 Back Cushion Zipper**

- The back cushion is detachable.

**9 Handle**

**10 Back Cover**

**11 Backrest Latch**

**12 Safety Precaution Label**

**13 Specification Label**

**14 Power Cord**

**15 Power Plug**

**16 Power Switch**

**17 Lock Switch**

**18 Lock Switch Key**

**19 Lock Switch Key Tag**

- To prevent children from accidentally swallowing the lock switch key.

**20 Wheels**

## SPECIFICATIONS

<b>Power Supply:</b>	AC 120 V 60 Hz
<b>Power Consumption:</b>	160 W
<b>Upper Body Massage</b>	
Message Area (Up-Down):	Approx. 26.6 in. (67.5 cm)
Message Area (Left-Right):	Distance between Massage Heads during Operation Approx. 2.4 in. – 7.1 in. (6.0 cm – 18.0 cm)
Up-Down Movement Speed:	Approx. 20 – 35 sec. return.
Massage Speed:	Knead: Approx. 20 cycles/min. – 30 cycles/min. Swedish: Approx. 30 cycles/min. – 50 cycles/min. Compression: Approx. 20 cycles/min. – 30 cycles/min. Hawaiian: Approx. 30 cycles/min. – 50 cycles/min. Soft Shiatsu: Approx. 150 cycles/min. – 210 cycles/min. Tap: Approx. 230 cycles/min. – 350 cycles/min. Full Roll: Approx. 20 sec./cycle – 35 sec./cycle [Movement range: Approx. 21.1 in. (53.5 cm)] Regional Roll: Approx. 7 sec./cycle – 9 sec./cycle [Movement range: Approx. 4.7 in. (12 cm)]
<b>Reclining Angle:</b>	Backrest: Approx. 120° – 170°
<b>Automatic Shut-Off:</b>	Approx. 15 min. for both upper and lower body

# CONTROLLER

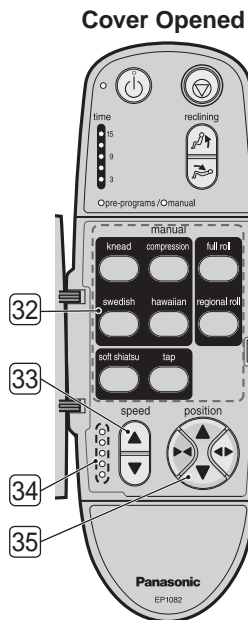
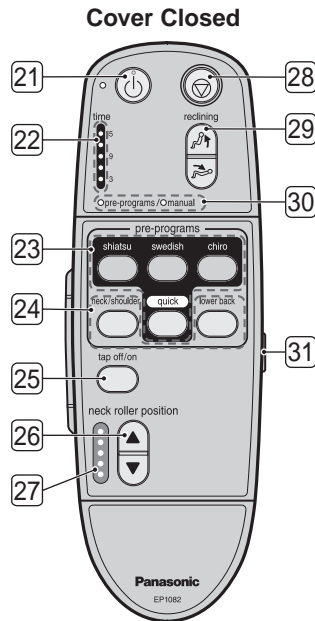

- 21 OFF/ON button**
  - Switches the controller on and off.
- 22 Time Indicator**
  - Displays time remaining before end of massage.
- 23 Pre-Programs buttons**
- 24 Massage Focus buttons**
  - Used to select focus of massage.
- 25 Tapping OFF/ON button**
- 26 Neck Roller Position button**
- 27 Neck Roller Position Indicator**
- 28 Quick Stop button**
  - Used to stop the massage immediately.
- 29 Reclining button**
  - Use this button to adjust the angle of the backrest.
- 30 Operation Indicator**
  - Displays operational status.
- 31 Cover**
- 32 Manual Operation buttons**
  - This allows you to select the massage action you desire. (See Page 13)
- 33 Speed Adjustment button**
  - Adjusts speed of upper body massage in 5 steps during manual operation.
- 34 Speed Indicator**
- 35 Massage Position Adjustment button**
  - Adjusts position of massage heads during manual operation. (See Page 13)

<b>Dimensions</b>	
When not reclined. (H x W x D):	Approx. 43.3 in. x 29.1 in. x 42.1 in. (110 cm x 74 cm x 107 cm)
When reclined. (H x W x D):	Approx. 24.0 in. x 29.1 in. x 61.0 in. (61 cm x 74 cm x 155 cm)
<b>Weight of Unit:</b>	Approx. 117 lbs (53 kg)
<b>Dimensions of Box (H x W x D):</b>	30.7 in. x 30.3 in. x 47.6 in. (78 cm x 77 cm x 121 cm)
<b>Weight in Box:</b>	Approx. 150 lbs (68 kg)
<b>Maximum User Weight:</b>	Approx. 264 lbs (120 kg)
<b>Minimum Distance from Wall:</b>	15.7 in. (40 cm)

# SETTING UP THE UNIT

## WHERE TO USE THE UNIT

Keep at least 3.9" (10 cm) away from the wall.

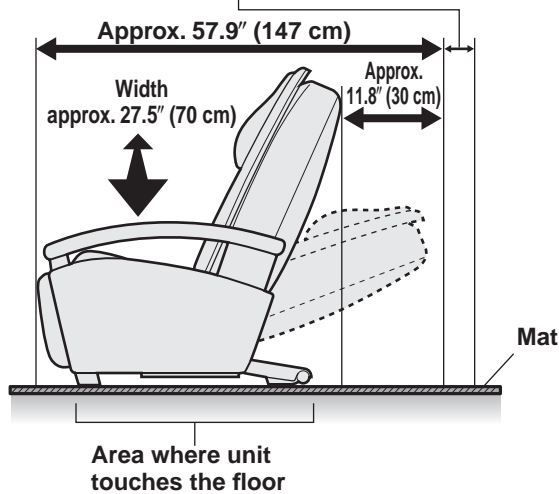

- Avoid places where the unit will be exposed to direct sunlight for long periods of time or places where it will be exposed to high temperatures, such as in front of a heater, etc., as this can cause discoloration or hardening of the leather.
  - Placing a mat or cloth under the unit is recommended to prevent floor damage. The size of the mat should be sufficient [at least 42.1 in. x 27.5 in. (107 cm x 70 cm)] to cover the areas where the unit touches.
  - Set the unit near the outlet.
- ⚠ See Warning No. 11 and 12 on page 1.

## 1 UNPACK THE UNIT AND RAISE THE BACKREST

### CAUTION

- When raising the backrest, be careful not to cause hands or feet to become caught between the backrest and the backrest latch or the backrest and the armrests. Failure to follow this precaution may result in injury.

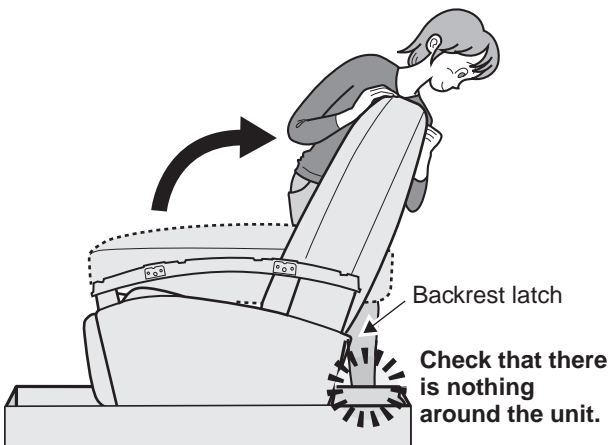

### 1 Remove the top of the shipping container.

- When packed for shipping the backrest is folded forward.

### 2 Remove the packing and cushioning materials and take out all accessories.

### 3 Raise the backrest.

- Do not connect the power cord to an electrical outlet during setup.
- Hold the backrest with both hands and lift in the direction of the arrow until it comes to a stop.
- Be careful the power cord and controller are not caught in the backrest.

## 2 INSPECT CONTENTS OF SHIPPING CONTAINER

Massage Lounger

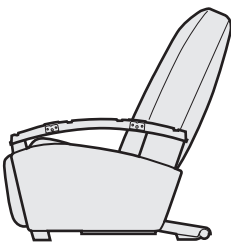

Pillow

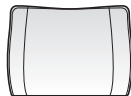

Armrests — 2

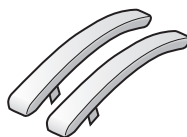

Back Cushion



Allen Key — 1  
Attachment Screws — 8



Lock Switch Key — 1



- The lock switch key has been inserted in the lock switch prior to leaving the factory.



### 3 HOW TO MOVE THE UNIT

#### Using the wheels to move the unit

- Hold the backrest to move the unit when using the wheels.
- It is easier to move the unit with the massage heads retracted and the backrest in the upright position.
- \*Place a mat or cloth on the floor and move the unit slowly to prevent floor damage.

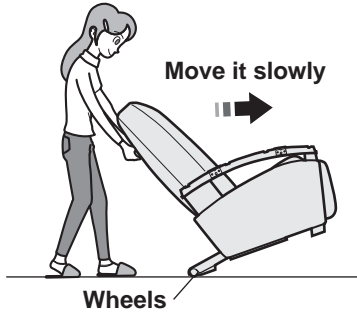

#### Lifting the Unit

- Move the unit by having 2 persons hold the armrests.
- \*Please hold the armrests securely to avoid dropping the unit as it may damage your floor.

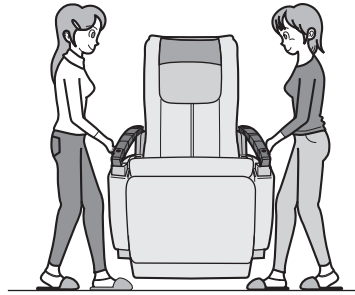

### 4 INSTALL THE ARMRESTS ON THE UNIT

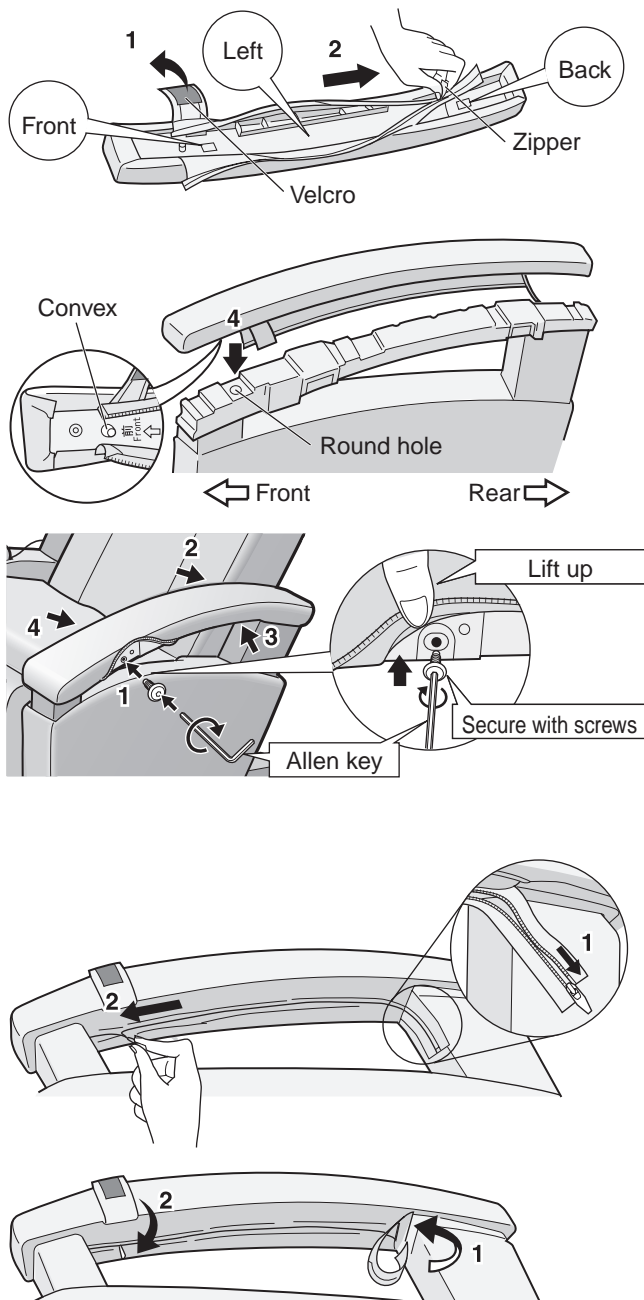

#### 1 Install the armrests.

- 1 Unfasten the velcro.
- 2 Unzip the zipper of the armrest completely.
- 3 Make sure to confirm the side (left or right) and direction (front or back) for each armrest.  
The illustration shows the left armrest. The right armrest is stamped "Front", "Right" and "Back".  
\*The left armrest must be installed on the left hand side of the unit.
- 4 Align the proper armrest with the unit and connect.  
Be careful not to catch the fabric between the chair and the armrest.

#### 2 Secure the armrests with attachment screws.

- (Total of 4 positions for a single armrest)  
Lift the fabric on the side of the armrest and insert the attachment screw onto the end of the Allen key, and then tighten.  
(Tighten the screws in the 4 positions lightly at first, and then tighten all screws firmly.)  
\*If the screw does not enter into the hole, tighten the screw by pushing the armrest from the top.

#### 3 Close the zipper at the bottom side of the armrests.

- When closing the zipper, be careful not to twist the end of the zipper.
- 1 Set the velcro.
  - 2 Zip the zipper.

#### 4 Put both ends of the zipper into the inside.

- 1 Turn in the edge of the zipper.
- 2 Fix the sliding tab of the zipper with the velcro.

## 5 FIX THE CONTROLLER CORD

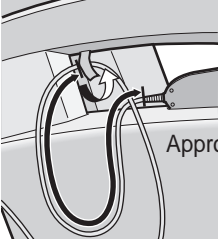

Use the controller cord velcros to secure the cord, leaving approximately 20 in. (51 cm) of free wire.

\* Confirm that there is a margin for the controller cord length when the backrest is reclined. (The illustration shows that the cord is attached to the right armrest.)

## 6 ATTACHING THE BACK CUSHION AND PILLOW

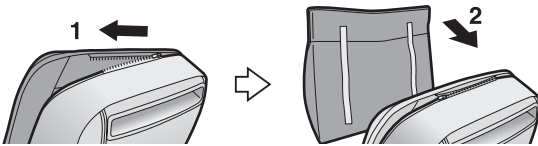

**1** Attach the back cushion using the zipper.

**2** Attach the pillow using the velcros.

## FOLDING THE BACKREST FORWARD (REPACKING)

### CAUTION

- Keep hands, feet, children, objects, etc., clear of openings on the unit, including seat and armrests; gaps between the unit and the floor; and the backrest's range of movement when being folded forward. Failure to do so could result in injury.
- The unit should not be turned on and the controls should not be operated on when the backrest is folded forward. Failure to follow these instructions could result in injury.
- The unit should not be climbed on and objects should not be placed on the unit when the backrest is folded forward. Failure to follow these instructions could result in damage to the unit.
- In the interests of safety, the backrest should always be folded forward by two persons.

**1** Press the OFF/ON button to switch off the power.

**2** Slide the power switch to the "off" position, lock it, and then unplug the power cord.

**3** Remove the back cushion and the pillow from the unit.

**4** Remove the armrest from the unit.

Refer to "INSTALL THE ARMRESTS ON THE UNIT" on page 6 and remove them in reverse order.

**5** Insert a screwdriver into the opening for the backrest latch approx. 1.6 in. (4 cm) from the upper edge of the opening (until the screwdriver contacts the backrest latch).

**6** Push tip of screwdriver downward approx. 1 in. (2.5 cm) to release backrest latch.

**7** Pull out screwdriver when pushing of backrest toward seat begins.

\*Be careful to avoid catching the controller or the cord between the backrest and the seat.

\*It is recommended that you move the unit before folding the backrest (upright position). When the backrest is folded, it is not fixed and is unstable.

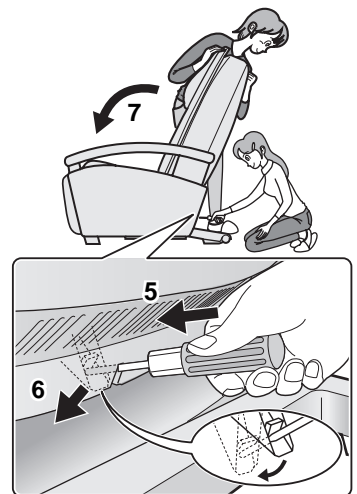

## BEFORE USING THE UNIT

### 1 CHECK THE SURROUNDING AREA

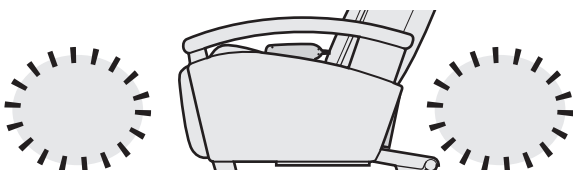

Check that there is nothing around the unit.

## 2 POWERING UP THE UNIT

⚠ See Warning No. 7 on page 1.

### 1 Make sure the power plug is functional.

- Make sure the power plug is undamaged. Make sure the power plug is free of foreign matter and debris.

### 2 Plug the power plug into an electrical outlet.

### 3 Verify that the lock switch key is turned to the “open” position.

- If in “lock” position, turn the lock switch key to “open”.

### 4 Slide the power switch to the “on” position.

## 3 CHECK THE UNIT

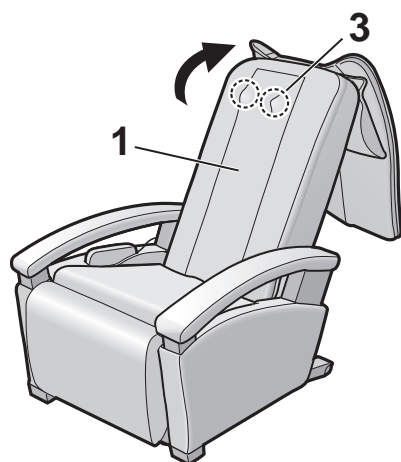

### 1 Make sure the chair covering is free of rips or tears.

### 2 Make sure there are no obstacles between the parts of the unit.

### 3 Make sure the massage heads are in the retracted position, i.e. they are parked to the left and right in the upper part of the backrest.

- If not retracted, press  twice to return the massage heads to the retracted position.

⚠ See Warning No. 14 on page 2.

## 4 ADJUSTING FOR CORRECT PILLOW HEIGHT

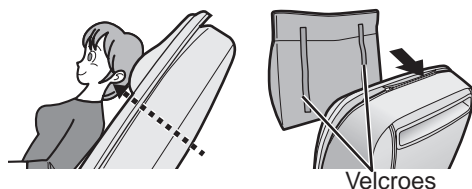

### Adjust the pillow height so that the bottom edge of the pillow is at ear level.

- If positioned too low, the pillow can lessen the effect of massage around the neck area.

## 5 ADJUSTING THE RECLINING ANGLE

Press  to adjust the angle of the backrest.

- With the button held down, movement will continue until a “beep-beep-beep” sound indicates the backrest has been raised or lowered as far as possible.

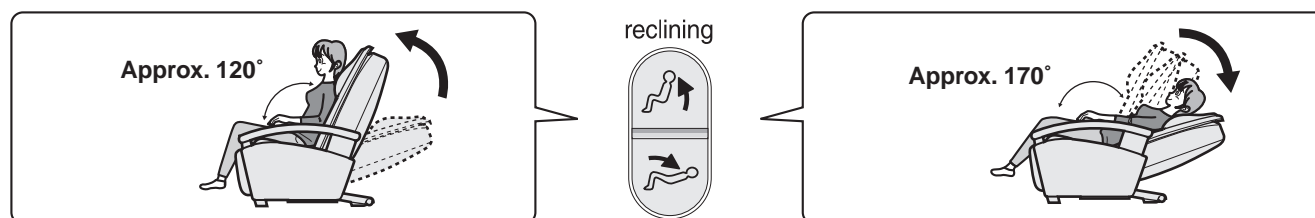

\*The reclining operation is a function that adjusts the angle of the backrest. Avoid using it for any other purposes, such as continuous up/down operation etc.

# USING PRE-PROGRAMS AND QUICK MASSAGE

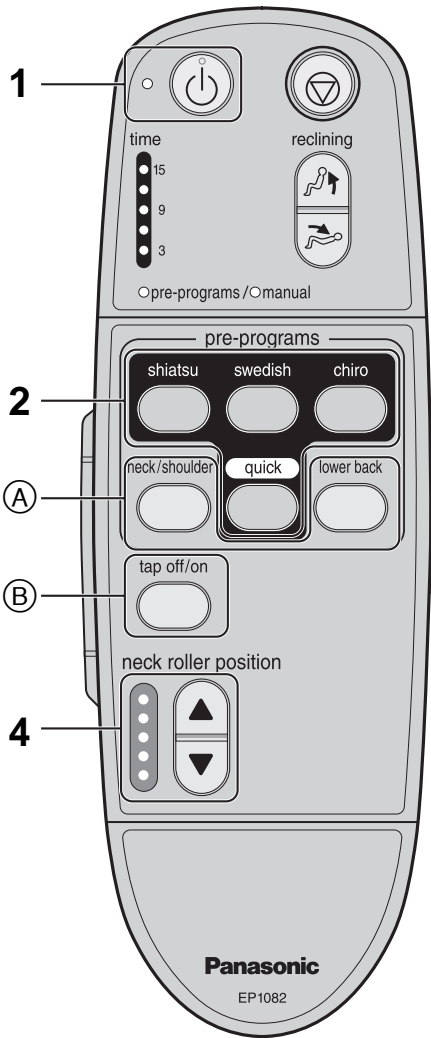

## 1 Press the OFF/ON button.

- The OFF/ON indicator will come on.

## 2 Select the pre-program you want.

- Please press one of the flashing buttons.
- If you press another Pre-Program button or a manual operation button during your selected pre-program massage, the massage will switch to the newly selected massage.
- Pressing a Pre-Program button automatically moves the backrest into massage position.

## 3 Sit as far back in the seat as possible with your head centered on the pillow.

## 4 Adjusting shoulder position

- When the shoulder position indicator is flashing, adjust the position of the massage heads (upper heads) so that they lightly touch the shoulders.

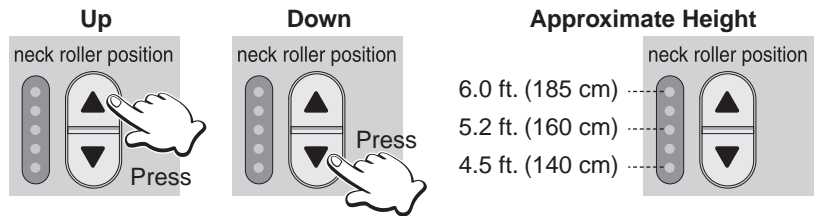
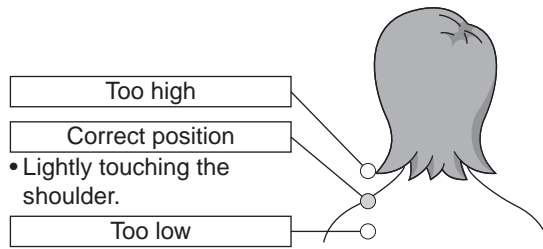

- 5-Stage adjustment [up and down approx. 3.9 in. (10 cm)]
- It is possible to change the position of the massage heads during the massage.
- When it is not possible to correctly adjust the shoulder position, you may have to slide your body and adjust it again.

### About the Time Indicator

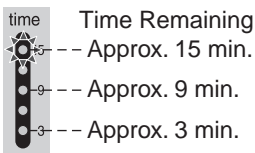

- Displays remaining massage time via flashing LED.
- Starts counting down from 15 minutes in increments of approximately 3 minutes.
- Flashing speeds up one minute before end of massage.

### Pre-Program and Quick Massage Characteristics

#### Shiatsu

Uses mainly Soft Shiatsu, Tap and Knead actions to comfortably loosen and provide relief from tension held at pressure points.  
**Recommended for those with severe stiffness and who want a stimulating massage.**

#### Swedish

Uses mainly Swedish, Hawaiian and Knead actions to evenly apply muscle-relaxing strokes all over.  
**Recommended for those who want a gentle relaxing massage.**

#### Chiro

Uses Full Roll and Compression to stretch all your muscles. A kneading action is applied to a stiff back and joints to refresh the posture and strengthen you against fatigue.  
**Recommended for those who want a fairly strong massage due to stiff muscles.**

#### Quick

Covers all areas using a variety of massage actions, all in a span of just five minutes.  
**Recommended for those who want a quick, relaxing massage.**

Persons whose height is less than 4.5 ft. (140 cm) or more than 6.0 ft. (185 cm) are recommended to use the unit in the manner described below when the massage heads do not touch their shoulders.

**Height is around 4.5 ft. (140 cm) or less**

Use by placing a cushion on the seat and sitting as far back as possible.



**Height is around 6.0 ft. (185 cm) or more**

Use by reclining the backrest and sliding your body downward.



## 5 Customize

### A Selecting an area for a focused massage

**Massaging the Neck and Shoulders**

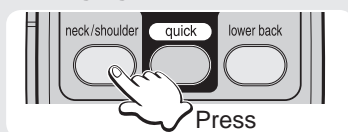

- The upper and lower back will also be massaged slightly.

**Massaging the Lower Back**

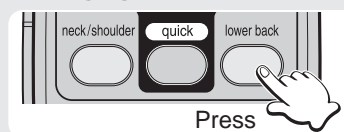

- The neck and shoulders will also be massaged slightly.

\*Press the button again to toggle it off.

### B Removing tapping from pre-programs

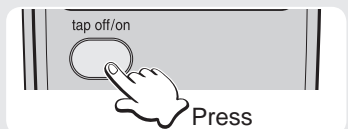

\*Press the button again to restore tapping to the program.

## 6 Auto shut-off in pre-programs

- The massage will end after approximately 15 minutes and the unit will automatically shut off.
- The massage heads will move to the retracted position and stop.
- The OFF/ON indicator will flash until the heads have stopped moving.
- If you want to continue using the unit, press the OFF/ON button. Please rest at least 10 minutes between massages.

### Stopping a pre-program



- Press the OFF/ON button.
- The massage heads will move to the retracted position, and the backrest will automatically return to its original position.

### Immediately stopping the massage



- Press the Quick Stop button.
- All movement will stop immediately.

# MANUAL OPERATION FOR THE UPPER BODY

English

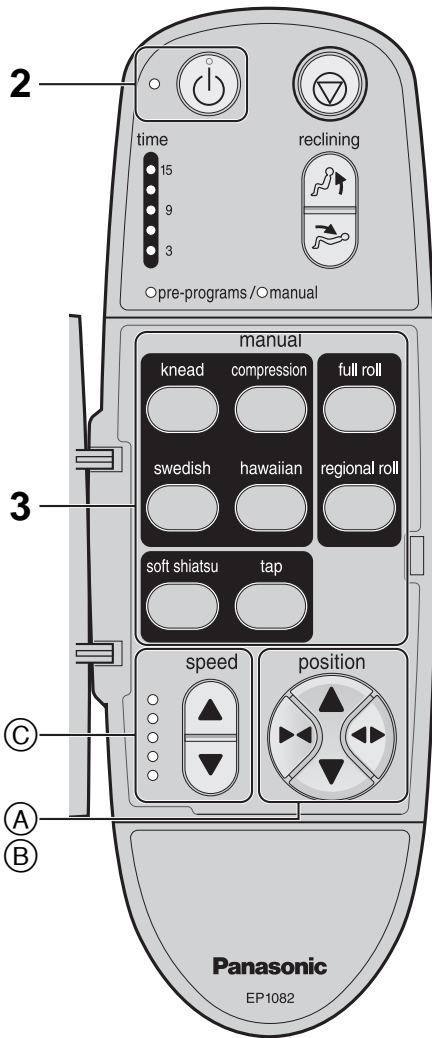

**1** Open the cover of the controller.

**2** Press the OFF/ON button.

- The OFF/ON indicator will come on.
- All of the Manual Operation buttons will start to flash.

**3** Select the massage type you want.

- Press the button of the massage you require. The button will light up and the massage will begin (See Page 12).
- The unit will automatically recline to the massage position. See Page 8 for a fine adjustment.

**4** Customized adjustments

You can adjust the position or speed of the massage heads, and you will hear a “beep-beep-beep” sound when it reaches its limit.

**(A)** Adjusting the Vertical Position of the Massage Heads

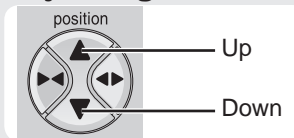

- Press the button once to move the position slightly [approx. 0.6 in. (15 mm)]. Press and hold the button to move the position continuously; release the button to stop the movement.

**(B)** Adjusting the Width between Massage Heads



- Tap, Soft Shiatsu, Full Roll, and Regional Roll can be adjusted in 3 steps.

**(C)** Adjusting Massage Speed

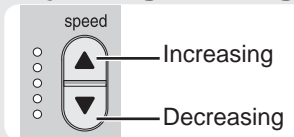

- Massage speed is adjustable in 5 steps.

**5** Auto shut-off in manual operation

- The massage will end after approximately 15 minutes and the unit will automatically shut off.
- The massage heads will move to the retracted position and stop.
- The OFF/ON indicator will flash until the heads have stopped moving.
- If you want to continue using the unit, please press the OFF/ON button. Please rest at least 10 minutes between massages.

## Massage Actions

### Knead

Feels like the fingers and thumbs of two hands squeezing in unison as they carefully work their way upwards to loosen stiffness. **Recommended for the area of the neck and shoulders.**

### Compression

Applies fluent alternating strokes to the left and right sides as if drawing stiffness to the outside. **Recommended for relaxation of the whole body.**

### Swedish

Feels like a two palms gliding over the skin as they rhythmically knead the muscles beneath. **Recommended for loosening up large areas of the back.**

### Hawaiian

Feels like two hands moving rhythmically in a circular pattern to relax and refresh the back. **Recommended for relieving tension in the lower back.**

### Soft Shiatsu

Feels like a pair of thumbs carefully alternating between the right and left sides as they zero in on their target. **Recommended for loosening up knots of tension.**

### Tap

Feels like the edges of two hands rhythmically tapping to penetrate into the body and relax muscles. **Recommended for use on the fine muscles of the neck or as a finishing massage.**

### Full Roll

From lower back to neck, you can feel it move 26.6 in. (67.5 cm) up and down the whole of the upper body. **Recommended for overall stretching of the back muscles.**

### Regional Roll

You can feel it travel up and down working on 3.9 in. (10 cm) localized areas of the back. **Recommended for focused rolling out of back muscles.**

## Combining Messages

- It is possible to combine message types.
- It is not possible to combine message types in the same category.

E.g. 1 Adding Tap when Knead is selected.

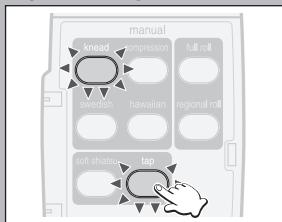

E.g. 2 Adding Full Roll to the selection.

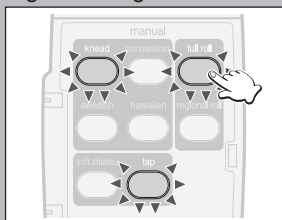

E.g. 3 Deselecting Full Roll.

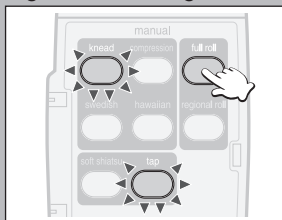

## Changing Message Types

E.g. 1 Changing message types in the same category. (Changing to Hawaiian when Knead is selected.)

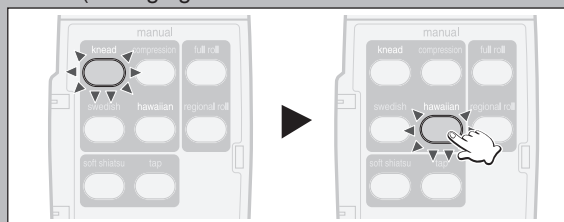

E.g. 2 Changing to a message type outside the category. (Changing to Tap when Knead is selected.)

- When Knead is combined with Tap, deselecting Knead will leave only Tap.

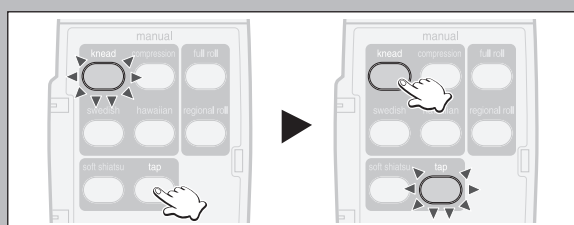

### NOTE:

- A built-in timer prevents overuse of the unit.
- When using manual operation, the timer automatically stops operation after 15 minutes.
- \*If you want to continue to use the unit, we recommend that you have a break of at least 10 minutes between massages to allow your body to rest.

### Stopping mid-way through a massage



Press

- Press the OFF/ON button.
- The massage heads will move to the retracted position, and the backrest will automatically return to its original position.

### Immediately stopping the massage



Press

- Press the Quick Stop button.
- All movement will stop immediately.

## AFTER COMPLETING THE MASSAGE

### RETURN THE SEAT TO THE ORIGINAL POSITION

- 1 Check that there is nothing in the vicinity of the backrest.
- 2 Press the OFF/ON button twice.
  - The backrest will automatically return to its original position.
- 3 Place the controller in its holder.
- 4 Return the pillow and the back cushion to their original positions.



### DISCONNECT THE POWER

⚠ See Warning No. 1 on page 1.

- 1 Slide the power switch to the “off” position.
- 2 Turn the lock switch key to the “lock” position.
- 3 Unplug the power cord.
- 4 The lock switch key must be stored out of the reach of children.

## CLEANING AND MAINTENANCE

⚠ See Danger No. 2 on page 1.

### LEATHER COVERING ON THE PILLOW, THE BACK CUSHION AND THE UNIT

- Wipe these areas with a soft, dry cloth.  
(Do NOT use cloths containing any kind of chemical, etc.)
- If the leather is particularly dirty, dampen with liquid soap and brush the surface. Wipe with a cloth dampened with water. Allow to dry naturally.  
(Do NOT use a hair dryer to try to dry the surfaces more quickly.)
- Wearing of denim, colored, patterned or other clothing with a tendency to fade should be avoided during use, as it could lead to discoloration of the leather.
- Please do NOT use thinners, benzine or alcohol.

### PIPE AND PLASTIC AREAS

- 1 Wipe the unit with a cloth that has been soaked in a mild detergent and then thoroughly wring out.
  - 2 Next wipe the unit with a cloth that has been moistened with just water and thoroughly wring out.  
\*Make sure you thoroughly wring out the cloth first when cleaning the controller.
  - 3 Allow the unit to dry naturally.
- Please do NOT use thinners, benzine or alcohol.

### COATED FABRIC

- 1 Wipe the seat fabric with a cloth that has been soaked in a mild detergent solution and then thoroughly wring out.
  - 2 Use a brush to apply a mild detergent to areas where the coated fabric has become particularly soiled. Be careful not to brush the fabric too much as this may damage it.
  - 3 Next wipe the fabric with a cloth that has been moistened with just water and then thoroughly wring out.
  - 4 Allow the fabric to dry naturally.
- Please do NOT use thinners, benzine or alcohol.



# TROUBLESHOOTING

Problem
<p>► <b>Cause and Remedy</b></p>
<p><b>Motor Noises</b></p> <ul style="list-style-type: none"> <li>• It sounds and feels like the massage heads are straining to get over wrinkles in the cloth.</li> <li>• The motor groans when it comes under load.</li> <li>• There is excessive noise during Tapping. (The noise is greater at the top of the unit.)</li> <li>• There is a creaking noise when the massage heads are in operation.</li> <li>• There is a rattling sound when the massage heads move up or down.</li> <li>• The belt can be heard rotating.</li> <li>• There is a rubbing sound produced by the massage heads rubbing on the seat fabric.</li> <li>• There is a noise when the backrest cushion moves over the armrest when the seat is reclining.</li> <li>• There is a noise when I sit down.</li> <li>• There is a strange sound when the massage heads move in and out.</li> <li>• When the power switch is turned on there is a humming sound.</li> </ul> <p>► These sounds are perfectly normal and will not have any effect on the operation of the unit.</p>
<p><b>The massage heads stop during operation.</b></p> <p>► When excessive force is applied to the massage heads during operation, in the interests of safety the massage heads may <u>stop moving</u>. If all markings and buttons on the controller start to flash, which is extremely unusual, turn off the power switch, wait for approximately 10 seconds and then turn the power switch on again. If the massage heads stop again, position yourself so that your back is not completely in contact with the backrest.</p>
<p><b>The massage heads do not come up to the shoulder or neck.</b></p> <p>► The position of the massage heads is incorrect. (See Page 10)</p>
<p><b>The height of the left and right massage heads is different.</b></p> <p>► An alternating tapping method is employed, which means that this phenomenon will naturally occur. There is nothing wrong with the unit.</p>
<p><b>It is not possible to recline the unit.</b></p> <p>► If the unit encounters an obstacle or if excessive force is exerted on it during operation, in the interests of safety the unit will <u>come to a stop</u>. If all markings and buttons on the controller start to flash, which is extremely unusual, turn off the power switch, wait for approximately 10 seconds and then turn the power switch on again.</p>
<p><b>Reclining does not take place even though a massage is started in pre-programs. (The seat does not automatically recline.)</b></p> <p>► In some cases the seat may not automatically recline depending on the position (angle) of the backrest (See Page 9)</p>
<p><b>The backrest does not return to the upright position.</b></p> <p>► The backrest will not return to the upright position if the timer is activated or the ⏻ button is pressed. (Pressing ⏻ twice will return the backrest to its original position.) (See Page 15)</p>
<p><b>It is not possible to switch from Swedish and Knead to Hawaiian and Compression.</b></p> <p>► Switching can be hindered when the user's body weight is not resting on the massage heads. Shift your weight so that your body is contact with the massage heads.</p>
<p><b>The unit will not operate at all.</b></p> <p>► • The power cord has been disconnected. (See Page 10) • The power switch on the unit has not been turned on. (See Page 10) • A Pre-Program button or Manual Operation button hasn't been pressed after pressing ⏻. (See Pages 9, 12)</p>
<p><b>The unit has been damaged.</b></p> <p>► Stop using the unit immediately.</p>
<p><b>The power cord or power plug is abnormally hot.</b></p> <p>► Stop using the unit immediately.</p>

⚠ See Warning No. 9 and 10 on page 2.

If service is needed please contact your local dealer or call 1-877 Panafix (723-2349).

**Panasonic Consumer  
Electronics Company**

One Panasonic Way 1H-1  
Secaucus, New Jersey 07094  
1-800-338-0552 for questions and comments.  
[www.panasonic.com/massage](http://www.panasonic.com/massage)

**Panasonic Canada Inc.**

5770 Ambler Drive  
Mississauga, ON L4W 2T3  
905-624-5010  
[www.panasonic.ca](http://www.panasonic.ca)