16-bit Proprietary Microcontroller

CMOS

F²MC-16LX MB90495 Series

MB90497/F497

1. OUTLINE

The MB90495-series with FULL-CAN interface and FLASH ROM is especially designed for automotive and industrial applications. Its main feature is the on-chip CAN Interface, which conforms to V2.0 Part A and Part B, while supporting a very flexible message buffer scheme, including 8 message buffers, and so offering more functions than a normal full CAN approach.

With the new 0.5 mm CMOS technology, Fujitsu now also offers on-chip FLASH-ROM program memory. An internal voltage booster removes the necessity for a second programming voltage. An on-chip voltage regulator provides 3V to the internal MCU core. This creates a major advantage in terms of EMI and power consumption.

The internal PLL clock frequency multiplier provides an internal 62.5 nsec instruction cycle time from an external 4 MHz clock. A 32kHz Subsystem clock has been included for power saving modes and real time measurement.

There are 2 on-chip UART's, which also provide synchronous communication modes. Furthermore the MCU features an 8 channel ADC, 8 channel External interrupt controller, two 16 bit PPG channels, 4 channel Input Capture Unit and a 16-bit free running I/O-timer.

MB90495 Series

2. FEATURES

- 16-bit core CPU; 4MHz external clock (16 MHz internal, 62.5 ns instruction cycle time)
- 32kHz Subsystem Clock
- 0.5 μ m CMOS Technology
- Internal voltage regulator supports 3V MCU core, offering low EMI and low power consumption figures
- 64 KB FLASH ROM; supports automatic programming, 10,000 erase cycles, 10 year data retention time and no second programming voltage required
- 2 KB static RAM
- FULL-CAN interface; conforming to Version 2.0 Part A and Part B, flexible message buffering (mailbox and FIFO buffering can be mixed)
- 2 UART's; both offering synchronous communication modes.
- Powerful interrupt functions (8 programmable priority levels; 8 external interrupts)
- I/O Timer
- A/D Converter: 8 channel analogue inputs (Resolution 10 bits or 8 bits)
- ICU (Input capture) 16bit * 4ch
- PPG (Programmable Pulse Generator) 16bit * 2ch; Can be configured as 8bit * 4ch
- Optimised instruction set for controller applications (bit, byte, word and long-word data types; 23 different addressing modes; barrel shift; variety of pointers)
- 4-byte instruction execution queue
- Signed multiply (16bit*16bit) and divide (32bit/16bit) instructions available
- Program Patch Function
- Fast Interrupt processing
- 16-bit reload timer: 2 channels
- Low Power Consumption - Several different Lo-Power modes: (Sleep, Stop, Watch,...)
- Package: QFP-64; 12mm x 12mm body, 0.65mm pin pitch
- QFP-64; 20mm x 18mm body, 1.0mm pin pitch

3. PRODUCT LINEUP

The following table provides an overview of the MB90495 Series

Features	MB90F497	MB90497
CPU	F2MC-16LX CPU	
System clock	On-chip PLL clock multiplier (x1, x2, x3, x4, 1/2 when PLL stop) Minimum instruction execution time: 62.5 ns (4 MHz osc. PLL x4)	
ROM	Boot-block Flash memory 64 Kbytes	Mask ROM 64 Kbytes
RAM	2 Kbytes	2 Kbytes
Technology	0.5 mm CMOS with on-chip voltage regulator for internal power supply + Flash memory On-chip charge pump for programming voltage	0.5 mm CMOS with on-chip voltage regulator for internal power supply
Operating voltage range	5 V +/- 10%	
Temperature range	- 40 to 85 °C	
Package	QFP64	

MB90495 Series

4. BLOCK DIAGRAM

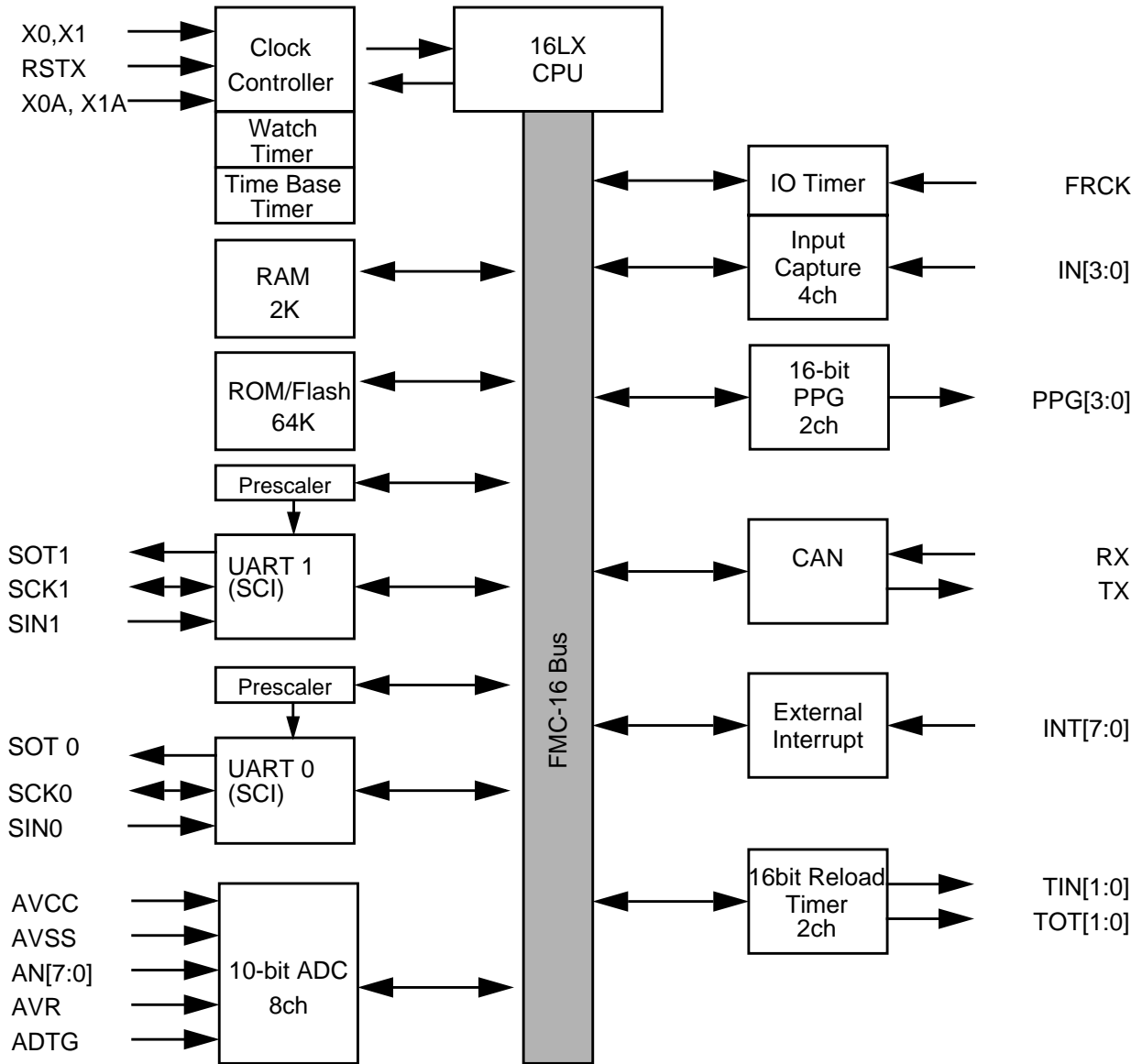

MB90495 Series

6. PIN DESCRIPTION

6.1 Pin Function

Pin No.		Pin Name	Circuit Type	Active	Level	at RST	Priority	Function
M06	M09							
2	1	P61	D	H	CMOS/ TTL	High-Z	Port	General pupose IO
		INT1						External Interrupt input 1
3	2	P62	D	H	CMOS/ TTL	High-Z	Port	General pupose IO
		INT2						External interrupt 2
4 to 11	3 to 10	P50 to P57	E	H	CMOS	High-Z	Port	General pupose IO
		AN0 to AN7						Inputs for A/D Converter
12	11	AVCC						Dedicated power supply for A/D Converter
13	12	AVR						Reference Volgate inupt for A/D Converter
14	13	AVSS						Dedicated power ground for A/D Converter
15	14	P60	D	H	CMOS/ TTL	High-Z	Port	General pupose IO
		INT0						External interrupt input 0
16	15	X0A	A					Low frequency oscillation input
17	16	X1A	A					Low frequency oscillation output
18	17	P63	D	H	CMOS/ TTL	High-Z	Port	General purpose IO
		INT3						External interrupt 3
19	18	MD0	C	H	CMOS			Mode input
20	19	RSTX	B	L	CMOS			Reset input
21	20	MD1	C	H	CMOS			Mode input
22	21	MD2	F	H	CMOS			Mode input
23	22	X0	A					High frequency oscillation input
24	23	X1	A					High frequency oscillation output
25	24	VSS						Power ground
26 to 33	25 to 32	P00 to P07	G	H	CMOS/ TTL	High-Z	Port	General purpose IO
		AD00 to AD07						Addresss Data Bus
34 to 37	33 to 36	P10 to P13	G	H	CMOS/ TTL	High-Z	Port	General pupose IO
		IN0 to IN3						Inputs for Input Captures
		AD08 to AD11						Address Data Bus
38 to 41	37 to 40	P14 to P17	G	H	CMOS/ TTL	High-Z	Port	General pupose IO
		PPG0 to PPG3						Outputs for Programable Pulse Generators
		AD12 to AD15						Address Data Bus
42	41	P20	G	H	CMOS/ TTL	High-Z	Port	General pupose IO
		TIN0						Input for 16-bit Reload Timer 0
		A16						Address Bus
43	42	P21	G	H	CMOS/ TTL	High-Z	Port	General pupose IO
		TOT0						Output for 16-bit Reload Timer 0
		A17						Address Bus
44	43	P22	G	H	CMOS/ TTL	High-Z	Port	General pupose IO
		TIN1						Input for 16-bit Reload Timer 1
		A18						Address Bus

MB90495 Series

Pin No.		Pin Name	Circuit Type	Active	Level	at RST	Priority	Function
M06	M09							
45	44	P23	G	H	CMOS/ TTL	High-Z	Port	General pupose IO
		TOT1						Output for 16-bit Reload Timer 1
		A19						Address Bus
46 to 49	45 to 48	P24 to P25	G	H	CMOS/ TTL	High-Z	Port	General pupose IO
		INT4 to INT 7						Inputs for External Interrupt
		A20 to A23						Address Bus
50	49	VSS						Ground
51	50	P30	G	H	CMOS/ TTL	High-Z	Port	General pupose IO
		SOT0						Output for UART 0
		ALE						Address Latch Enable output
52	51	P31	G	H	CMOS/ TTL	High-Z	Port	General pupose IO
		SCK0						Input/Output for UART 0
		RDX						Read Enable output
53	52	P32	G	H	CMOS/ TTL	High-Z	Port	General pupose IO
		SIN0						Input for UART 0
		WRLX						Write Enable Low-byte output
54	53	P33	G	H	CMOS/ TTL	High-Z	Port	General pupose IO
		WRHX						Write Enable High-byte output
55	54	P34	G	H	CMOS/ TTL	High-Z	Port	General pupose IO
		HRQ						Halt Request input
56	55	P35	G	H	CMOS/ TTL	High-Z	Port	General pupose IO
		HAKX						Halt Acknowledge output
57	56	VCC						Power supply
58	57	C						Pin for capacitor for the internal power supply.
59	58	P36	G	H	CMOS/ TTL	High-Z	Port	General pupose IO
		FRCK						Inupt for IO Timer
		RDY						Ready input
60	59	P37	D	H	CMOS	High-Z	Port	General pupose IO
		ADTG						Trigger inupt for A/D Converter
		CLK						Clock output
61	60	P40	G	H	CMOS/ TTL	High-Z	Port	General pupose IO
		SIN1						Input for UART 1
62	61	P41	G	H	CMOS/ TTL	High-Z	Port	General pupose IO
		SCK1						Input/Output for UART 1
63	62	P42	G	H	CMOS/ TTL	High-Z	Port	General pupose IO
		SOT1						Output for UART 1
64	63	P43	G	H	CMOS/ TTL	High-Z	Port	General pupose IO
		Tx						CAN Transmit pin
1	64	P44	G	H	CMOS/ TTL	High-Z	Port	General pupose IO
	Rx	CAN receive pin						

MB90495 Series

6.2 I/O Circuit Types

Circuit	Drawing	Comment
A		
B		
C		
D		
E		
F		
G		

7. HANDLING DEVICES

(1) Preventing latch-up

CMOS IC chips may suffer latch-up under the following conditions:

A voltage higher than V_{cc} or lower than V_{ss} is applied to an input or output pin.

A voltage higher than the rated voltage is applied between V_{cc} and V_{ss} .

The AV_{cc} power supply is applied before the V_{cc} voltage.

Latch-up may increase the power supply current drastically, causing thermal damage to the device.

(2) Handling unused input pins

Do not leave unused input pins open, as doing so may cause misoperation of the device. Use a pull-up or pull-down resistor.

(3) Using external clock

To use external clock, drive the X0 and X1 pins in reverse phase.

Below is a diagram of how to use external clock.

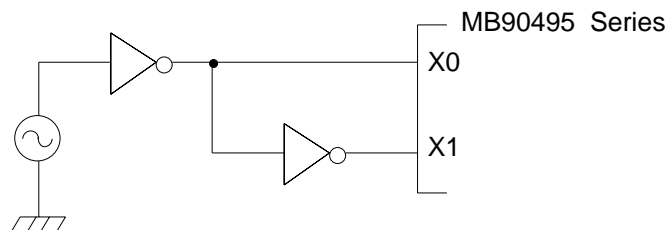

Figure 7.1 Using external clock

(4) Power supply pins (V_{cc}/V_{ss})

Ensure that all V_{cc} -level power supply pins are at the same potential. In addition, ensure the same for all V_{ss} -level power supply pins. (See the figure below.) If there are more than one V_{cc} or V_{ss} system, the device may operate incorrectly even within the guaranteed operating range. Note that this product may not have as many power pins as pictured in the figure.

MB90495 Series

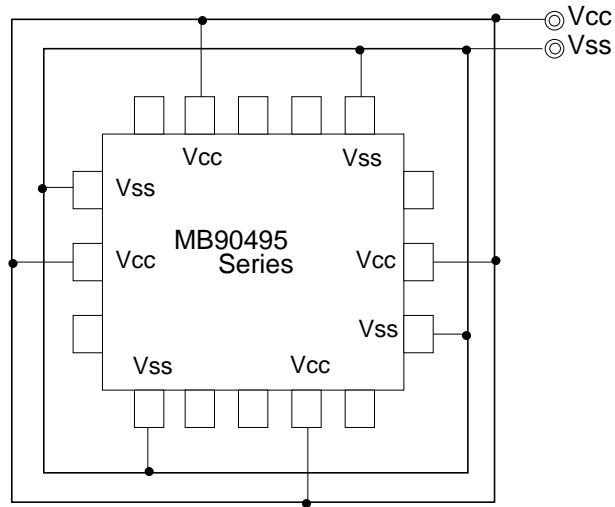

Figure 7.2 Power pin connections

(5) Pull-up/down resistors

The MB90495 Series does not support internal pull-up/down resistors. Use external components where needed.

8. ADDRESS SPACE

	MB90V495	MB90F497	MB90497
FFFFFFH	ROM FF	FLASH ROM FF	ROM FF
FF0000H			
FEFFFFFFH	ROM FE	No Access	
FE0000H			
FDFFFFFFH	ROM FD		
FD0000H			
FCFFFFFFH	ROM FC		
FC0000H			
FBFFFFFFH	ROM FB	External bus access	External bus access
FB0000H			
FAFFFFFFH	ROM FA		
FA0000H			
010000H			
00FFFFFFH	FF ROM mirror	FF ROM mirror	FF ROM mirror
004000H			
003FFFFH	Extended I/O	Extended I/O	Extended I/O
003800H			
		External bus access	External bus access
0018FFH			
0010FFH		RAM mirror ¹ Do not use	RAM mirror Do not use.
000900H			
0008FFH			
000100H			
0000BFH			
000000H	I/O	I/O	I/O

1. The RAM contents of 0000_H - 08FF_H is mirrored to 0900_H - 10FF_H. The RAM mirror area should not be accessed for proper operation.

MB90495 Series

9. REGISTER MAP

Address	Register	Abbreviation	Peripheral	Access	Initial value
00 H	Port 0 data register	PDR0	Port 0	R/W	XXXXXXXX
01 H	Port 1 data register	PDR1	Port 1	R/W	XXXXXXXX
02 H	Port 2 data register	PDR2	Port 2	R/W	XXXXXXXX
03 H	Port 3 data register	PDR3	Port 3	R/W	XXXXXXXX
04 H	Port 4 data register	PDR4	Port 4	R/W	XXXXXXXX
05 H	Port 5 data register	PDR5	Port 5	R/W	XXXXXXXX
06 H	Port 6 data register	PDR6	Port 6	R/W	XXXXXXXX
07-0F H	Reserved				
10 H	Port 0 direction register	DDR0	Port 0	R/W	00000000
11 H	Port 1 direction register	DDR1	Port 1	R/W	00000000
12 H	Port 2 direction register	DDR2	Port 2	R/W	00000000
13 H	Port 3 direction register	DDR3	Port 3	R/W	00000000
14 H	Port 4 direction register	DDR4	Port 4	R/W	00000000
15 H	Port 5 direction register	DDR5	Port 5	R/W	00000000
16 H	Port 6 direction register	DDR6	Port 6	R/W	00000000
17-1A H	Reserved				
1B H	Analog Input Enable	ADER	Port 5, A/D	R/W	11111111
1C - 1F H	Reserved				
20 H	Serial Mode Register 1	SMR0	UART0	R/W	00000000
21 H	Serial Control Register 1	SCR0		R/W	00000100
22 H	Input/Output Data Register 1	SIDR0/SODR0		R/W	XXXXXXXX
23 H	Serial Status Register 1	SSR0		R/W	00001_00
24 H	UART 0 Prescaler Control Register	CDCR0		R/W	0___1111
25 H	UART 0 edge select	SES0		R/W	_____1
26 H	Serial Mode Control Register 1	SMC1	UART1	R/W	00XXXXX00
27 H	Serial Control Register	SRC1		R/W	00000X00
28 H	Input/Output Data Register 1	SIDR1/SODR1		R/W	XXXXXXXX
29 H	Serial Status Register 1	SSR1		R/W	XXXXXX000
2A H	Reserved				
2B H	UART 1 Prescaler Control Register	CDCR0	Prescaler UART 1	R/W	0___0000
2C - 2F H	Reserved				
30 H	External Interrupt Enable	ENIR	External Interrupt	R/W	00000000
31 H	External Interrupt Request	EIRR		R/W	XXXXXXXX
32 H	External Interrupt Level	ELVR		R/W	00000000
33 H	External Interrupt Level	ELVR		R/W	00000000
34 H	A/D Control Status 0	ADCS0	A/D Converter	R/W	00000000
34 H	A/D Control Status 1	ADCS1		R/W	00000100
36 H	A/D Data 0	ADCR0		R	XXXXXXXX
37 H	A/D Data 1	ADCR1		R/W	00000_XX
38-3FH	Reserved				
40 H	PPG0 operation mode control register	PPGC0	16-bit Programmable Pulse Generator 0/1	R/W	0_00x__1
41 H	PPG1 operation mode control register	PPGC1		R/W	0_00x001
42 H	PPG0 and PPG1 clock select register	PPG01		R/W	000000__

Address	Register	Abbreviation	Peripheral	Access	Initial value
43 H	Reserved				
44 H	PPG2 operation mode control register	PPGC2	16-bit Programmable Pulse Generator 2/3	R/W	0_00X__1
45 H	PPG3 operation mode control register	PPGC3		R/W	0_00X001
46 H	PPG2 and PPG3 clock select register	PPG23		R/W	000000__
47-4FH	Reserved				
50 H	Input Capture 0	IPCP0	Input Capture 0/1	R	XXXXXXXX
51 H	Input Capture 0	IPCP0		R	XXXXXXXX
52 H	Input Capture 1	IPCP1		R	XXXXXXXX
53 H	Input Capture 1	IPCP1		R	XXXXXXXX
54 H	Input Capture Control Status 0/1	ICS01	Input Capture 0/1/2/3	R/W	XX000000
55 H	Input Capture Control Status 2/3	ICS23		R/W	XX000000
56 H	Timer Data	TCDT	I/O Timer	R/W	00000000
57 H	Timer Data	TCDT		R/W	00000000
58 H	Timer Control	TCCS		R/W	00000000
59 H	Timer Control	TCCS		R/W	0__00000
5A H	Input Capture 2	IPCP2	Input Capture 2/3	R	XXXXXXXX
5B H	Input Capture 2	IPCP2		R	XXXXXXXX
5C H	Input Capture 3	IPCP3		R	XXXXXXXX
5D H	Input Capture 3	IPCP3		R	XXXXXXXX
5E - 65 H	Reserved				
66 H	Timer Control Status 0	TMCSR0	16-bit Reload Timer 0	R/W	00000X00
67 H	Timer Control Status 0	TMCSR0		R/W	____0000
68 H	Timer Control Status 1	TMCSR1	16-bit Reload Timer 1	R/W	00000X00
69 H	Timer Control Status 1	TMCSR1		R/W	____0000
6A - 6E H	Reserved				
6F H	ROM Mirror	ROMM	ROM Mirror	R/W	000____1
70-7F H	Reserved				
80-8F H	Reserved for CAN 1 Interface . Refer to "CAN Controller"				
90-9D H	Reserved				
9E H	ROM Correction Control Status	PACSR	ROM Correction	R/W	11000000
9F H	Delayed Interrupt/release	DIRR	Delayed Interrupt	R/W	____0
A0 H	Low-power Mode	LPMCR	Low Power Controller	R/W	00011000
A1 H	Clock Selector	CKSCR	Low Power Controller	R/W	11111100
A2-A4 H	Reserved				
A5 H	Automatic ready function select reg.	ARSR	W	External Memory Access	0011__00
A6 H	External address output control reg.	HACR	W		00000000
A7 H	Bus control signal select register	ECSR	W		0000000_
A8 H	Watchdog Control	WDTC	Watchdog Timer	R/W	XXXXX111
A9 H	Time Base Timer Control	TBTC	Time Base Timer	R/W	1__0X100
AA-AD H	Reserved				
AE H	Flash Control Status (Flash only, otherwise reserved)	FMCS	Flash Memory	R/W	000X0000
AF H	Reserved				

MB90495 Series

Address	Register	Abbreviation	Peripheral	Access	Initial value
B0 H	Interrupt control register 00	ICR00	Interrupt controller	R/W	11000111
B1 H	Interrupt control register 01	ICR01		R/W	11000111
B2 H	Interrupt control register 02	ICR02		R/W	11000111
B3 H	Interrupt control register 03	ICR03		R/W	11000111
B4 H	Interrupt control register 04	ICR04		R/W	11000111
B5 H	Interrupt control register 05	ICR05		R/W	11000111
B6 H	Interrupt control register 06	ICR06		R/W	11000111
B7 H	Interrupt control register 07	ICR07		R/W	11000111
B8 H	Interrupt control register 08	ICR08		R/W	11000111
B9 H	Interrupt control register 09	ICR09		R/W	11000111
BA H	Interrupt control register 10	ICR10		R/W	11000111
BB H	Interrupt control register 11	ICR11		R/W	11000111
BC H	Interrupt control register 12	ICR12		R/W	11000111
BD H	Interrupt control register 13	ICR13		R/W	11000111
BE H	Interrupt control register 14	ICR14		R/W	11000111
BF H	Interrupt control register 15	ICR15		R/W	11000111
CO-FF H	Reserved				
1FF0H-1FF5H	ROM correction				
3900 H	Timer 0/Reload 0	TMR0/TMRL0	16-bit Reload Timer 0	R/W	XXXXXXXX
3901 H	Timer 0/Reload 0	TMR0/TMRL0		R/W	XXXXXXXX
3902 H	Timer 1/Reload 1	TMR1/TMRL1	16-bit Reload Timer 1	R/W	XXXXXXXX
3903 H	Timer 1/Reload 1	TMR1/TMRL1		R/W	XXXXXXXX
3904-390FH	Reserved				
3910 H	PPG0 Reload L	PRL0	16-bit Programable Pulse Generator 0/1	R/W	XXXXXXXX
3911 H	PPG0 Reload H	PRLH0		R/W	XXXXXXXX
3912 H	PPG1 Reload L	PRL1		R/W	XXXXXXXX
3913 H	PPG1 Reload H	PRLH1		R/W	XXXXXXXX
3914 H	PPG2 Reload L	PRL2	16-bit Programable Pulse Generator 2/3	R/W	XXXXXXXX
3915 H	PPG2 Reload H	PRLH2		R/W	XXXXXXXX
3916 H	PPG3 Reload L	PRL3		R/W	XXXXXXXX
3917 H	PPG3 Reload H	PRLH3		R/W	XXXXXXXX
3918-392FH	Reserved				
3930-3BFFH	Reserved				
3C00-3CFFH	Reserved for CAN 1 Interface. Refer to "CAN Controller"				
3D00-3DFFH	Reserved for CAN 1 Interface. Refer to "CAN Controller"				
3E00-3EFFH	Reserved				
3FF0-3FFFH	Reserved				

10. CAN CONTROLLER

The CAN controller has the following features:

- Conforms to CAN Specification Version 2.0 Part A and B
 - Supports transmission/reception in standard frame and extended frame formats
- Supports transmitting of data frames by receiving remote frames
- 8 transmitting/receiving message buffers
 - 29-bit ID and 8-byte data
 - Multi-level message buffer configuration
- Provides full-bit comparison, full-bit mask, acceptance register 0/acceptance register 1 for each message buffer as 1D acceptance mask
 - Two acceptance mask registers in either standard frame format or extended frame formats
- Bit rate programmable from 10 Kbits/s to 2 Mbits/s (when input clock is at 16 MHz)

MB90495 Series

10.1 List of Control Registers

Address	Register	Abbreviation	Access	Initial Value
000080H	Message buffer valid register	BVALR	R/W	00000000
000081H	Unused			
000082H	Transmit request register	TREQR	R/W	00000000
000083H	Unused			
000084H	Transmit cancel register	TCANR	W	00000000
000085H	Unused			
000086H	Transmit complete register	TCR	R/W	00000000
000087H	Unused			
000088H	Receive complete register	RCR	R/W	00000000
000089H	Unused			
00008AH	Remote request receiving register	RRTRR	R/W	00000000
00008BH	Unused			
00008CH	Receive overrun register	ROVRR	R/W	00000000
00008DH	Unused			
00008EH	Receive interrupt enable register	RIER	R/W	00000000
00008FH	Unused			
003D00H	Control status register	CSR	R/W, R	00---000 0---0-1
003D01H				
003D02H	Last event indicator register	LEIR	R/W	----- 000-0000
003D03H				
003D04H	Receive/transmit error counter	RTEC	R	00000000 00000000
003D05H				
003D06H	Bit timing register	BTR	R/W	-11111111 11111111
003D07H				
003D08H	IDE register	IDER	R/W	xxxxxxxx
003D09H	Unused			
003D0AH	Transmit RTR register	TRTRR	R/W	00000000
003D0BH	Unused			
003D0CH	Remote frame receive waiting register	RFWTR	R/W	xxxxxxxx
003D0DH	Unused			
003D0EH	Transmit interrupt enable register	TIER	R/W	00000000
003D0FH	Unused			
003D10H	Acceptance mask select register	AMSR	R/W	xxxxxxxx xxxxxxxx
003D11H				
003D12H	Unused			
003D13H				
003D14H	Acceptance mask register 0	AMR0	R/W	xxxxxxxx xxxxxxxx
003D15H				xxxxx--- xxxxxxxx
003D16H				
003D17H				
003D18H	Acceptance mask register 1	AMR1	R/W	xxxxxxxx xxxxxxxx
003D19H				xxxxx--- xxxxxxxx
003D1AH				
003D1BH				

10.2 List of Message Buffers (ID Registers)

Address	Register	Abbreviation	Access	Initial Value
003C00H to 003C0FH	General-purpose RAM	--	R/W	XXXXXXXX to XXXXXXXX
003C10H	ID register 0	IDR0	R/W	XXXXXXXX XXXXXXXX
003C11H				XXXXX--- XXXXXXXX
003C12H				
003C13H				
003C14H	ID register 1	IDR1	R/W	XXXXXXXX XXXXXXXX
003C15H				XXXXX--- XXXXXXXX
003C16H				
003C17H				
003C18H	ID register 2	IDR2	R/W	XXXXXXXX XXXXXXXX
003C19H				XXXXX--- XXXXXXXX
003C1AH				
003C1BH				
003C1CH	ID register 3	IDR3	R/W	XXXXXXXX XXXXXXXX
003C1DH				XXXXX--- XXXXXXXX
003C1EH				
003C1FH				
003C20H	ID register 4	IDR4	R/W	XXXXXXXX XXXXXXXX
003C21H				XXXXX--- XXXXXXXX
003C22H				
003C23H				
003C24H	ID register 5	IDR5	R/W	XXXXXXXX XXXXXXXX
003C25H				XXXXX--- XXXXXXXX
003C26H				
003C27H				
003C28H	ID register 6	IDR6	R/W	XXXXXXXX XXXXXXXX
003C29H				XXXXX--- XXXXXXXX
003C2AH				
003C2BH				
003C2CH	ID register 7	IDR7	R/W	XXXXXXXX XXXXXXXX
003C2DH				XXXXX--- XXXXXXXX
003C2EH				
003C2FH				

MB90495 Series

10.3 List of Message Buffers (DLC Registers and Data Registers)

Address	Register	Abbreviation	Access	Initial Value
003C30H 003C31H	DLC register 0	DLCR0	R/W	----XXXX
003C32H 003C33H				
003C34H 003C35H	DLC register 1	DLCR1	R/W	----XXXX
003C36H 003C37H				
003C38H 003C39H	DLC register 2	DLCR2	R/W	----XXXX
003C3AH 003C3BH				
003C3CH 003C3DH	DLC register 3	DLCR3	R/W	----XXXX
003C3EH 003C3FH				
003C40H to 003C47H	DLC register 4	DLCR4	R/W	----XXXX
003C48H to 003C4FH				
003C50H to 003C57H	DLC register 5	DLCR5	R/W	----XXXX
003C58H to 003C5FH				
003C60H to 003C67H	DLC register 6	DLCR6	R/W	----XXXX
003C68H to 003C6FH				
003C70H to 003C77H	DLC register 7	DLCR7	R/W	----XXXX
003C78H to 003C7FH				
003C40H to 003C47H	Data register 0 (8 bytes)	DTR0	R/W	XXXXXXXX to XXXXXXXX
003C48H to 003C4FH	Data register 1 (8 bytes)	DTR1	R/W	XXXXXXXX to XXXXXXXX
003C50H to 003C57H	Data register 2 (8 bytes)	DTR2	R/W	XXXXXXXX to XXXXXXXX
003C58H to 003C5FH	Data register 3 (8 bytes)	DTR3	R/W	XXXXXXXX to XXXXXXXX
003C60H to 003C67H	Data register 4 (8 bytes)	DTR4	R/W	XXXXXXXX to XXXXXXXX
003C68H to 003C6FH	Data register 5 (8 bytes)	DTR5	R/W	XXXXXXXX to XXXXXXXX
003C70H to 003C77H	Data register 6 (8 bytes)	DTR6	R/W	XXXXXXXX to XXXXXXXX
003C78H to 003C7FH	Data register 7 (8 bytes)	DTR7	R/W	XXXXXXXX to XXXXXXXX

11. INTERRUPTS

Interrupt cause	DMA Ch.	Interrupt vector		Interrupt control register	
		Number	Address	Number	Address
Reset	---	# 08	FFFFDCH	---	---
INT9 instruction	---	# 09	FFFFD8H	---	---
Exception	---	# 10	FFFFD4H	---	---
CAN RX	---	# 11	FFFFD0H	ICR00	0000B0H
CAN TX/NS	---	# 12	FFFFCCH		
Reserved	---	# 13	FFFFC8H	ICR01	0000B1H
Reserved	---	# 14	FFFFC4H		
External Interrupt INT0/INT1	---	# 15	FFFFC0H	ICR02	0000B2H
Time Base Timer	---	# 16	FFFFBCH		
16-bit Reload Timer 0	---	# 17	FFFFB8H	ICR03	0000B3H
A/D Converter	---	# 18	FFFFB4H		
I/O Timer	---	# 19	FFFFB0H	ICR04	0000B4H
External Interrupt INT2/INT3	---	# 20	FFFFACH		
Reserved	---	# 21	FFFFA8H	ICR05	0000B5H
PPG 0/1	---	# 22	FFFFA4H		
Input Capture 0	---	# 23	FFFFA0H	ICR06	0000B6H
External Interrupt INT4/INT5	---	# 24	FFFF9CH		
Input Capture 1	---	# 25	FFFF98H	ICR07	0000B7H
PPG 2/3	---	# 26	FFFF94H		
External Interrupt INT6/INT7	---	# 27	FFFF90H	ICR08	0000B8H
Watch Timer	---	# 28	FFFF8CH		
Reserved	---	# 29	FFFF88H	ICR09	0000B9H
Input Capture 2/3	---	# 30	FFFF84H		
Reserved	---	# 31	FFFF80H	ICR10	0000BAH
Reserved	---	# 32	FFFF7CH		
Reserved	---	# 33	FFFF78H	ICR11	0000BBH
Reserved	---	# 34	FFFF74H		
Reserved	---	# 35	FFFF70H	ICR12	0000BCH
16-bit Reload Timer 1	---	# 36	FFFF6CH		
UART 0 RX	---	# 37	FFFF68H	ICR13	0000BDH
UART 0 TX	---	# 38	FFFF64H		
UART 1 RX	---	# 39	FFFF60H	ICR14	0000BEH
UART 1 TX	---	# 40	FFFF5CH		
Flash Memory	---	# 41	FFFF58H	ICR15	0000BFH
Delayed interrupt	---	# 42	FFFF54H		

MB90495 Series

12. ELECTRICAL CHARACTERISTICS

12.1 Absolute Maximum Ratings

($V_{SS} = AV_{SS} = 0\text{ V}$)

Parameter	Symbol	Rated Value		Units	Remarks
		Min.	Max.		
Power supply voltage	V_{CC}	$V_{SS} - 0.3$	$V_{SS} + 6.0$	V	
	AV_{CC}	$V_{SS} - 0.3$	$V_{SS} + 6.0$	V	$V_{CC} = AV_{CC}$ *1
	AVR	$V_{SS} - 0.3$	$V_{SS} + 6.0$	V	AV_{CC} AVR AV_{SS}
Input voltage	V_i	$V_{SS} - 0.3$	$V_{SS} + 6.0$	V	*2
Output voltage	V_o	$V_{SS} - 0.3$	$V_{SS} + 6.0$	V	*2
"L" level max. output current	I_{OL}	—	15	mA	
"L" level avg. output current	I_{OLAV}	—	4	mA	Average value over a period of 100ms
"L" level max. overall output current	I_{OL}	—	100	mA	
"L" level avg. overall output current	I_{OLAV}	—	50	mA	Average value over a period of 100ms
"H" level max. output current	I_{OH}	—	-15	mA	
"H" level avg. output current	I_{OHAV}	—	-4	mA	Average value over a period of 100ms
"H" level max. overall output current	I_{OH}	—	-100	mA	
"H" level avg. overall output current	I_{OHAV}	—	-50	mA	Average value over a period of 100ms
Power consumption	P_D	—	300	mW	
Operating temperature	T_A	-40	+85	°C	
Storage temperature	T_{STG}	-55	+150	°C	

*1: Set AV_{CC} and V_{CC} to the same voltage. Make sure that AV_{CC} does not exceed V_{CC} and that the voltage at the analog inputs does not exceed AV_{CC} when the power is switched on.

*2: V_i and V_o should not exceed $V_{CC} + 0.3\text{ V}$. V_i should not exceed the specified ratings. However if the maximum current to/from an input is limited by some means with external components, the I_I rating supercedes the V_i rating.

12.2 Recommended Conditions

($V_{SS} = AV_{SS} = 0\text{ V}$)

Parameter	Symbol	Rated Value			Units	Remarks
		Min.	Typ.	Max.		
Power supply voltage	V_{CC}	4.5	5.0	5.5	V	Normal operating conditions
	AV_{CC}	3.0		5.5	V	Maintains RAM data in stop mode.
Input H voltage	V_{IHS}	$0.8 V_{CC}$		$V_{CC} + 0.3$	V	CMOS hysteresis input pin
	V_{IHM}	$V_{CC} - 0.3$		$V_{CC} + 0.3$	V	MD input pin
Input L voltage	V_{ILS}	$V_{SS} - 0.3$		$0.2 V_{CC}$	V	CMOS hysteresis input pin
	V_{ILM}	$V_{SS} - 0.3$		$V_{SS} + 0.3$	V	MD input pin
Smooth capacitor	C_S	0.022	0.1	1.0	μF	Use a ceramic capacitor or capacitor of better AC characteristics. Capacitor at the VCC should be greater than this capacitor.
Operating temperature	T_A	-40		+85	$^{\circ}\text{C}$	

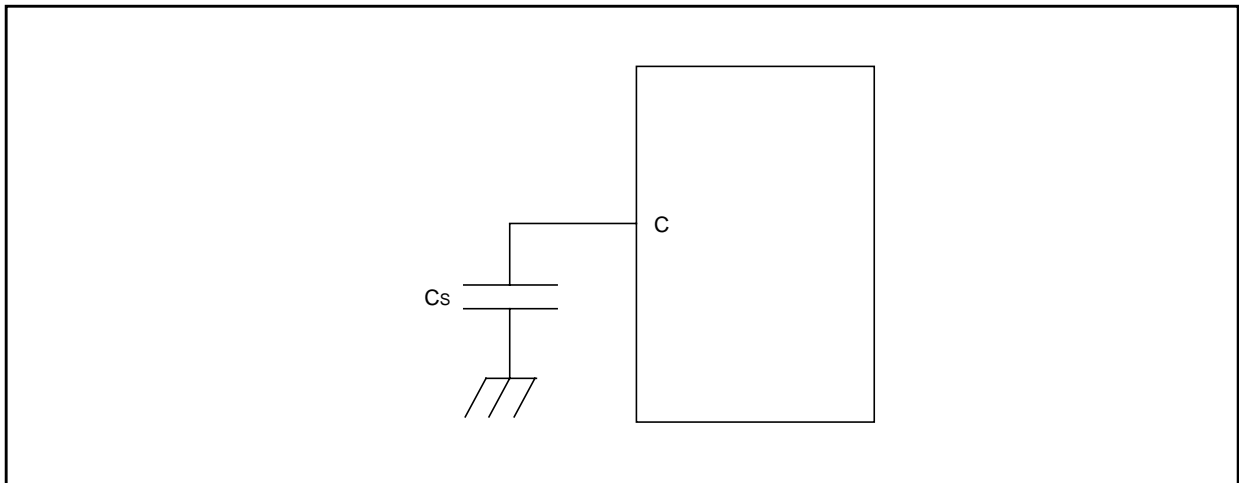

Figure 12.1 C-Pin Connection Diagram

MB90495 Series

13. DC CHARACTERISTICS

($T_A = -40$ to $+85^\circ\text{C}$, $V_{CC} = 5.0\text{ V } 10\%$, $V_{SS} = AV_{SS} = 0\text{ V}$)

Parameter	Symbol	Pin	Test Condition	Rated Value			Units	Remarks	
				Min.	Typ.	Max.			
Output H voltage	V_{OH}	All output pins	$V_{CC} = 4.5\text{ V}$, $I_{OH} = -4.0\text{ mA}$	$V_{CC} - 0.5$	—	—	V		
Output L voltage	V_{OL}	All output pins	$V_{CC} = 4.5\text{ V}$, $I_{OL} = 4.0\text{ mA}$	—	—	0.4	V		
Input leak current	I_{IL}		$V_{CC} = 5.5\text{ V}$, $V_{SS} < V_i < V_{CC}$	-5	—	5	μA		
Power supply current *		V_{CC}	$V_{CC} = 5.0\text{ V} \pm 10\%$, Int. frequency: 16 MHz, At normal operating	—	35	40	mA	MB90497	
				—	35	40	mA	MB90F497	
			$V_{CC} = 5.0\text{ V} \pm 10\%$, Int. frequency: 16 MHz, At flash programming		45	50	mA	MB90F497	
			$V_{CC} = 5.0\text{ V} \pm 10\%$, Int. frequency: 16 MHz, At flash erasing		45	50	mA	MB90F497	
			I_{CCS}	$V_{CC} = 5.0\text{ V} \pm 10\%$, Int. frequency: 16 MHz, At sleep	—	11	18	mA	MB90497
					—	11	18	mA	MB90F497
			I_{CTS}	$V_{CC} = 5.0\text{ V } 10\%$, Int. frequency: 16 MHz, At timer mode		0.6	1.2	mA	MB90497
						0.6	1.2	mA	MB90F497
			I_{CCL}	$V_{CC} = 5.0\text{ V}$, Int. frequency: 8 kHz, At sub operation	—	16	20	μA	MB90497
					—	116	220	μA	MB90F497
			I_{CCLS}	$V_{CC} = 5.0\text{ V}$, Int. frequency: 8 kHz, At sub sleep	—	7.5	10	μA	MB90497
					—	8	20	μA	MB90F497
			I_{CCT}	$V_{CC} = 5.0\text{ V}$, Int. frequency: 8 kHz, At watch mode	—	3	5	μA	MB90497
					—	3	10	μA	MB90F497
			I_{CCH}	$V_{CC} = 5.0\text{ V} \pm 10\%$, At stop, $T_A = 25^\circ\text{C}$	—	2	20	μA	MB90497
					—	2	20	μA	MB90F497
Input capacity	C_{IN}	Other than AV_{CC} , AV_{SS} , AVR, C, V_{CC} , V_{SS}	—	—	10	80	pF		

*: Current values are tentative. They are subject to change without notice according to improvements in the characteristics. The power supply current testing conditions are when using the external clock with square pulses.

14. AC CHARACTERISTICS

14.1 Clock Timing

(T_A = -40 to +85°C, V_{CC} = 5.0 V 10%, V_{SS} = AV_{SS} = 0 V)

Parameter	Symbol	Pin	Rated Value			Units	Remarks
			Min.	Typ.	Max.		
Oscillation frequency	f _c	X0, X1	3	—	16	MHz	
	f _{CL}	X0A, X1A	—	32.768	—	kHz	
Oscillation cycle time	t _{H CYL}	X0, X1	62.5	—	333	ns	
	t _{L CYL}	X0A, X1A	—	30.5	—	μs	
Frequency deviation with PLL *	Δf	—	—	—	5	%	
Input clock pulse width	P _{WH} , P _{WL}	X0	10	—	—	ns	Duty ratio is about 30 to 70%.
	P _{WLH} , P _{WLL}	X0A	—	15.2	—	μs	
Input clock rise and fall time	t _{CR} , t _{CF}	X0	—	—	5	ns	When using external clock
Machine clock frequency	f _{CP}	—	1.5	—	16	MHz	When using main clock
	f _{LCP}	—	—	8.192	—	kHz	When using sub-clock
Machine clock cycle time	t _{CP}	—	62.5	—	666	ns	When using main clock
	t _{LCP}	—	—	122.1	—	μs	When using sub-clock

*: Frequency deviation indicates the maximum frequency difference from the target frequency when using a multiplied clock.

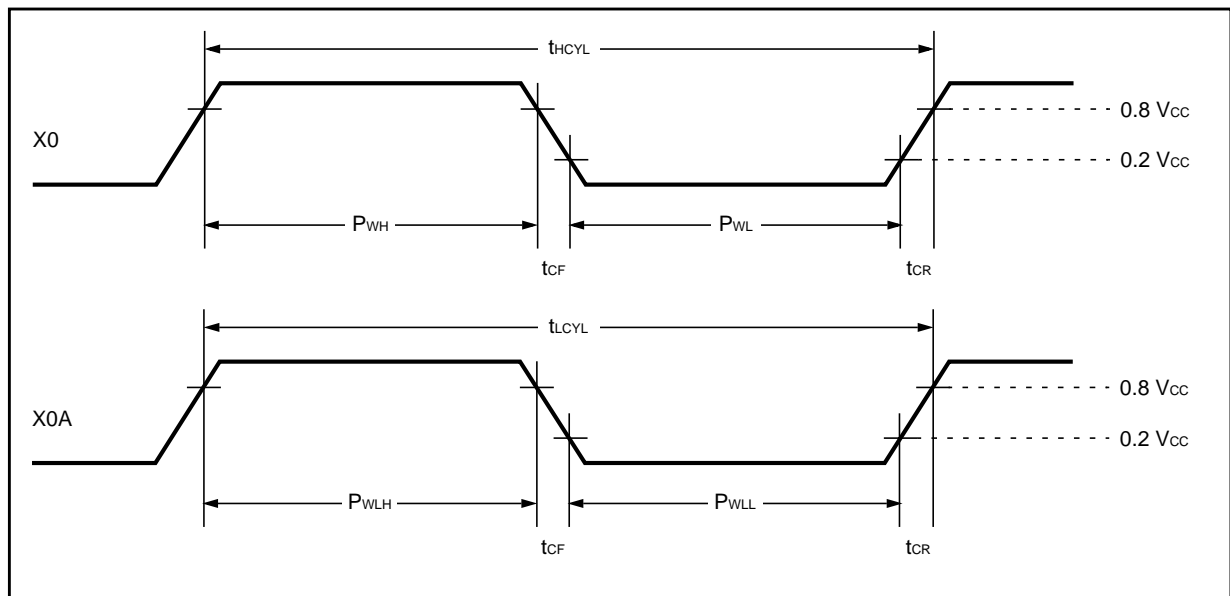
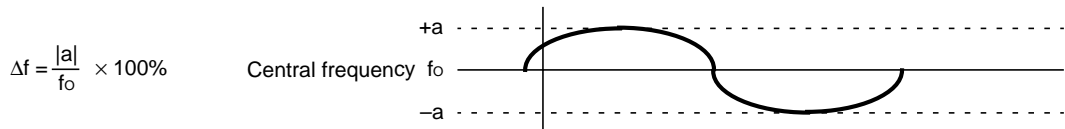

MB90495 Series

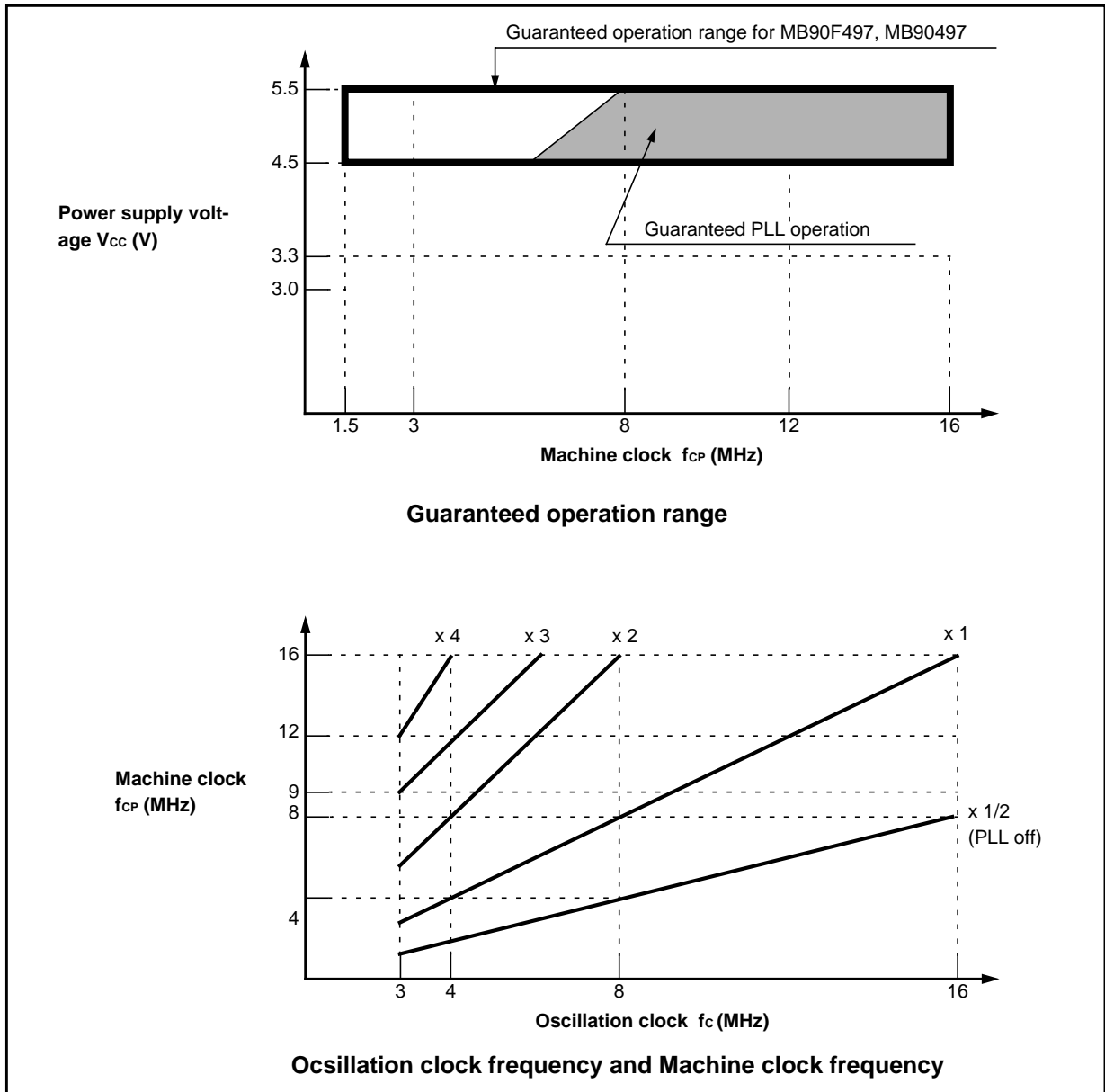

Figure 14.1 Clock Timing

AC characteristics are set to the measured reference voltage values below.

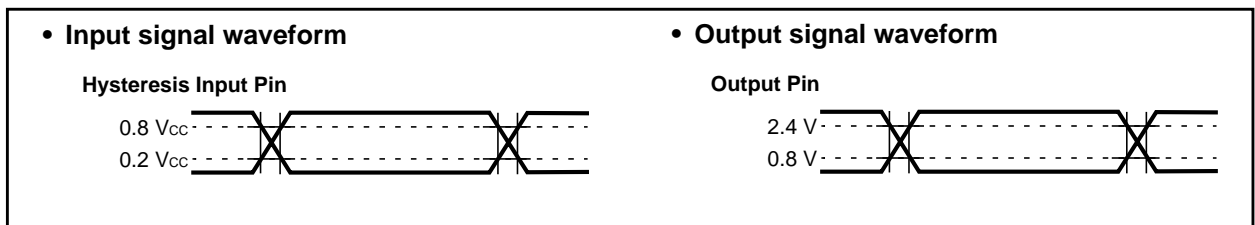

Figure 14.2 Measured Reference Voltages

14.2 Clock Output Timing

($T_A = -40$ to $+85^\circ\text{C}$, $V_{CC} = 5.0\text{ V } \pm 10\%$, $V_{SS} = AV_{SS} = 0.0\text{ V}$)

Parameter	Symbol	Pin	Test Condition	Rated Value		Units	Remarks
				Min.	Max.		
Cycle time	t_{CYC}	CLK	$V_{CC} = 5\text{ V } \pm 10\%$	62.5	—	ns	
CLK $\uparrow \Rightarrow$ CLK \downarrow	t_{CHCL}			20	—	ns	

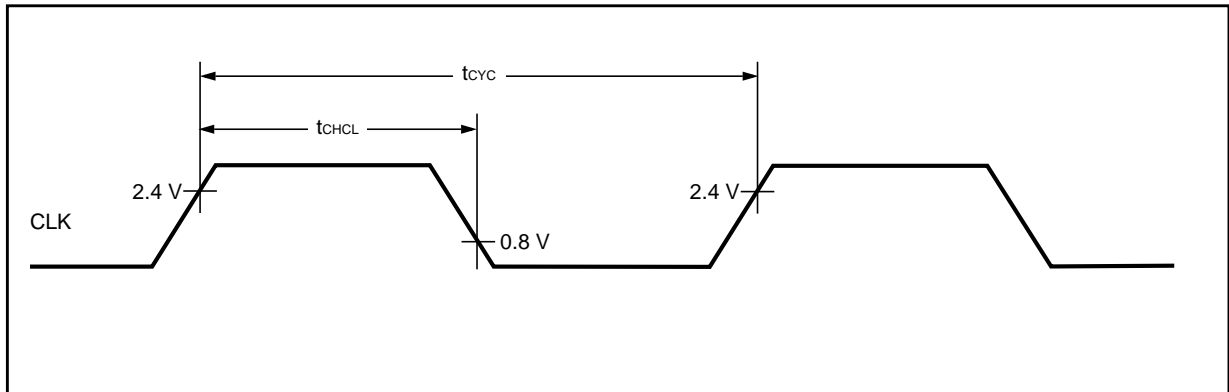

Figure 14.3 Measured CLK timing

MB90495 Series

14.3 Reset Input

($T_A = -40$ to $+85^\circ\text{C}$, $V_{CC} = 5.0\text{ V } 10\%$, $V_{SS} = AV_{SS} = 0.0\text{ V}$)

Parameter	Symbol	Pin	Rated Value		Units	Remarks
			Min.	Max.		
Reset input time	t_{RSTL}	RST	16 t_{CP}	—	ns	

“ t_{CP} ” represents one cycle time of the machine clock.

Any reset can not fully initialize the Flash Memory if it is performing the automatic algorithm.

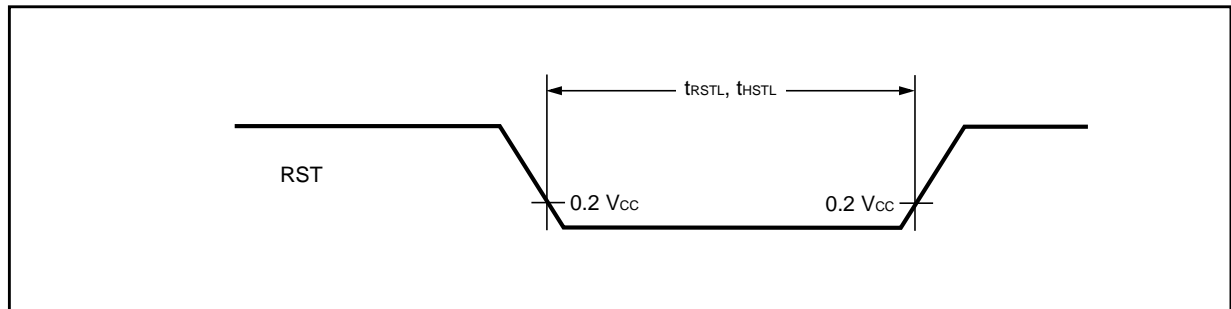

Figure 14.4 Measured RST timing

14.4 Power On Reset

($T_A = -40$ to $+85^\circ\text{C}$, $V_{CC} = 5.0\text{ V } 10\%$, $V_{SS} = AV_{SS} = 0.0\text{ V}$)

Parameter	Symbol	Pin	Test Condition	Rated Value		Units	Remarks
				Min.	Max.		
Power on rise time	t_R	V_{CC}	—	0.05	30	ms	
Power off time	t_{OFF}	V_{CC}		50	—	ms	Due to repetitive operation

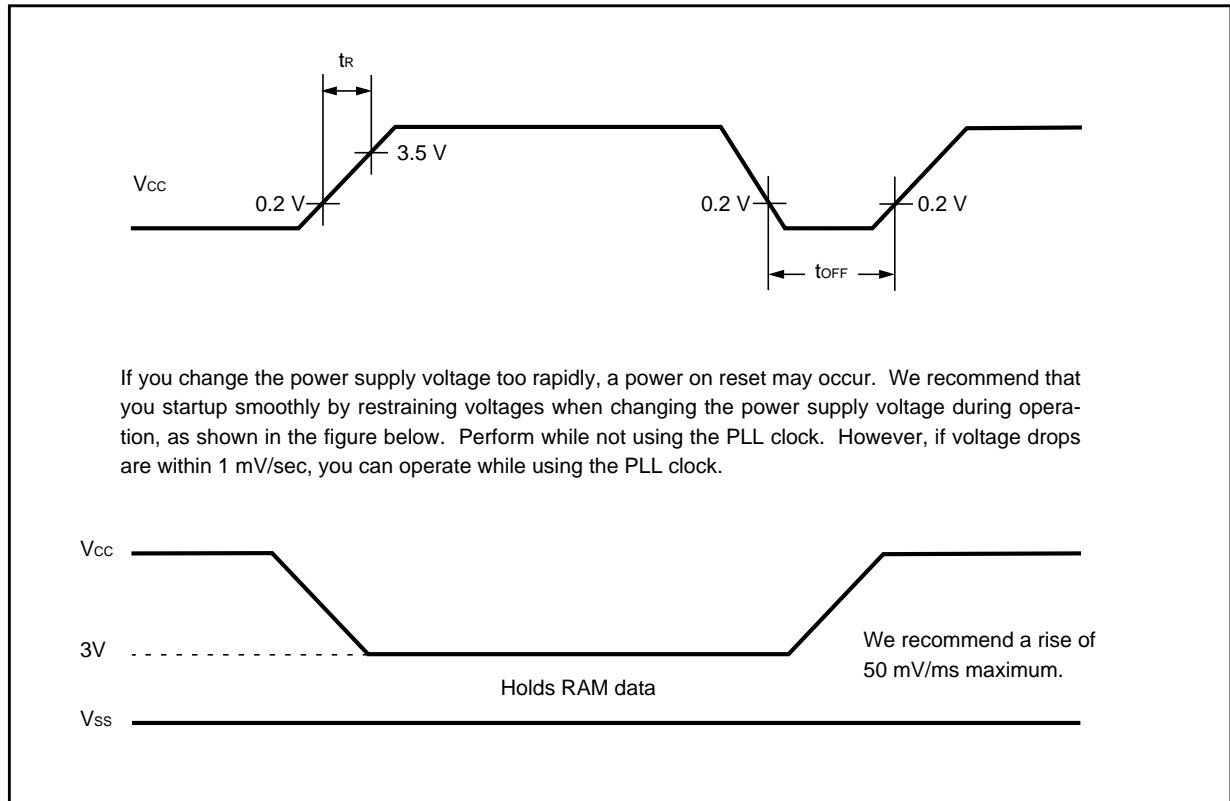

Figure 14.5 Power On Reset Timing

MB90495 Series

14.5 External Bus Timing (Read)

($T_A = -40$ to $+85^\circ\text{C}$, $V_{CC} = 4.5$ to 5.5 V, $V_{SS} = 0$ V)

Parameter	Symbol	Pin	Test Condition	Rated Value		Units	Remarks
				Min.	Max.		
ALE pulse width	t_{LHLL}	ALE	—	$t_{CP}/2 - 20$		ns	
Valid address \Rightarrow ALE \downarrow time	t_{AVLL}	ALE, A23 - A16, AD15 - AD00		$t_{CP}/2 - 20$	—	ns	
ALE $\downarrow \Rightarrow$ Address valid time	t_{LLAX}	ALE, AD15 - AD00		$t_{CP}/2 - 15$	—	ns	
Valid address $\Rightarrow \overline{RD} \downarrow$ time	t_{AVRL}	A23 - A16, AD15 - AD00, \overline{RD}		$t_{CP} - 15$	—	ns	
Valid address \Rightarrow Valid data input	t_{AVDV}	A23 - A16, AD15 - AD00		—	$5 t_{CP}/2 - 60$	ns	
\overline{RD} pulse width	t_{RLRH}	\overline{RD}		$3 t_{CP}/2 - 20$	—	ns	
$\overline{RD} \downarrow \Rightarrow$ Valid data input	t_{RLDV}	\overline{RD} , AD15 - AD00		—	$3 t_{CP}/2 - 60$	ns	
$\overline{RD} \uparrow \Rightarrow$ Data hold time	t_{RHDX}	\overline{RD} , AD15 - AD00		0	—	ns	
$\overline{RD} \downarrow \Rightarrow$ ALE \uparrow time	t_{RHLL}	\overline{RD} , ALE		$t_{CP}/2 - 15$	—	ns	
$\overline{RD} \uparrow \Rightarrow$ Address valid time	t_{RHAX}	\overline{RD} , A23 - A16		$t_{CP}/2 - 10$	—	ns	
Valid address \Rightarrow CLK \uparrow time	t_{AVCH}	A23 - A16, AD15 - AD00, CLK		$t_{CP}/2 - 20$	—	ns	
$\overline{RD} \downarrow \Rightarrow$ CLK \uparrow time	t_{RLCH}	\overline{RD} , CLK		$t_{CP}/2 - 20$	—	ns	
ALE $\downarrow \Rightarrow \overline{RD} \downarrow$ time	t_{LLRL}	ALE, \overline{RD}		$t_{CP}/2 - 15$	—	ns	

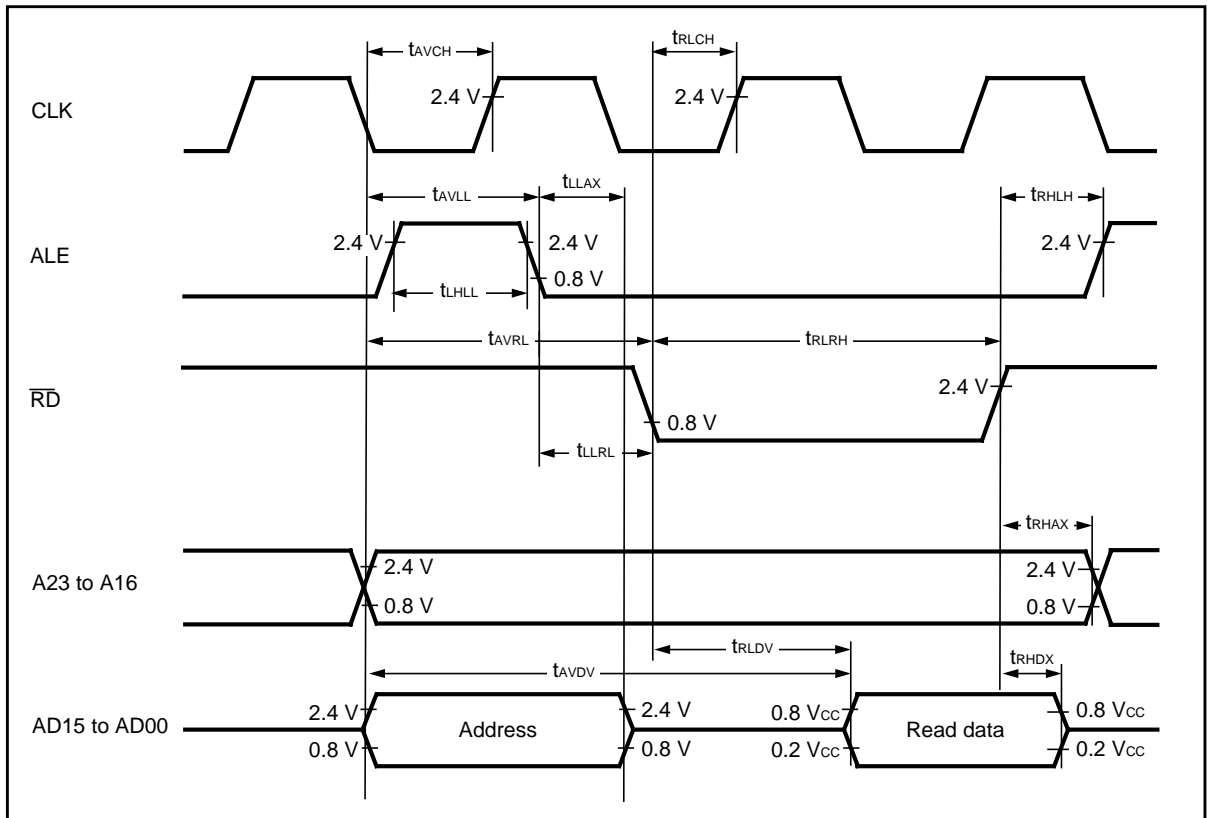

Figure 14.6 Bus Timing (Read)

MB90495 Series

14.6 External Bus Timing (Write)

($T_A = -40$ to $+85^\circ\text{C}$, $V_{CC} = 4.5$ to 5.5 V, $V_{SS} = 0$ V)

Parameter	Symbol	Pin	Test Condition	Rated Value		Units	Remarks
				Min.	Max.		
Valid address $\Rightarrow \overline{\text{WR}} \downarrow$ time	t_{AVWL}	A23 - A16, AD15 - AD00, $\overline{\text{WR}}$	—	$t_{\text{CP}} - 15$	—	ns	
$\overline{\text{WR}}$ pulse width	t_{WLWH}	$\overline{\text{WR}}$		$3 t_{\text{CP}}/2 - 20$	—	ns	
Valid data output $\Rightarrow \overline{\text{WR}} \uparrow$ time	t_{DVWH}	AD15 - AD00, $\overline{\text{WR}}$		$3 t_{\text{CP}}/2 - 20$	—	ns	
$\overline{\text{WR}} \uparrow \Rightarrow$ Data hold time	t_{WHDX}	AD15 - AD00, $\overline{\text{WR}}$		20	—	ns	
$\overline{\text{WR}} \uparrow \Rightarrow$ Address valid time	t_{WHAX}	A23 - A16, $\overline{\text{WR}}$		$t_{\text{CP}}/2 - 10$	—	ns	
$\overline{\text{WR}} \uparrow \Rightarrow$ ALE \uparrow time	t_{WHLH}	$\overline{\text{WR}}$, ALE		$t_{\text{CP}}/2 - 15$	—	ns	
$\overline{\text{WR}} \downarrow \Rightarrow$ CLK \uparrow time	t_{WLCH}	$\overline{\text{WR}}$, CLK		$t_{\text{CP}}/2 - 20$	—	ns	

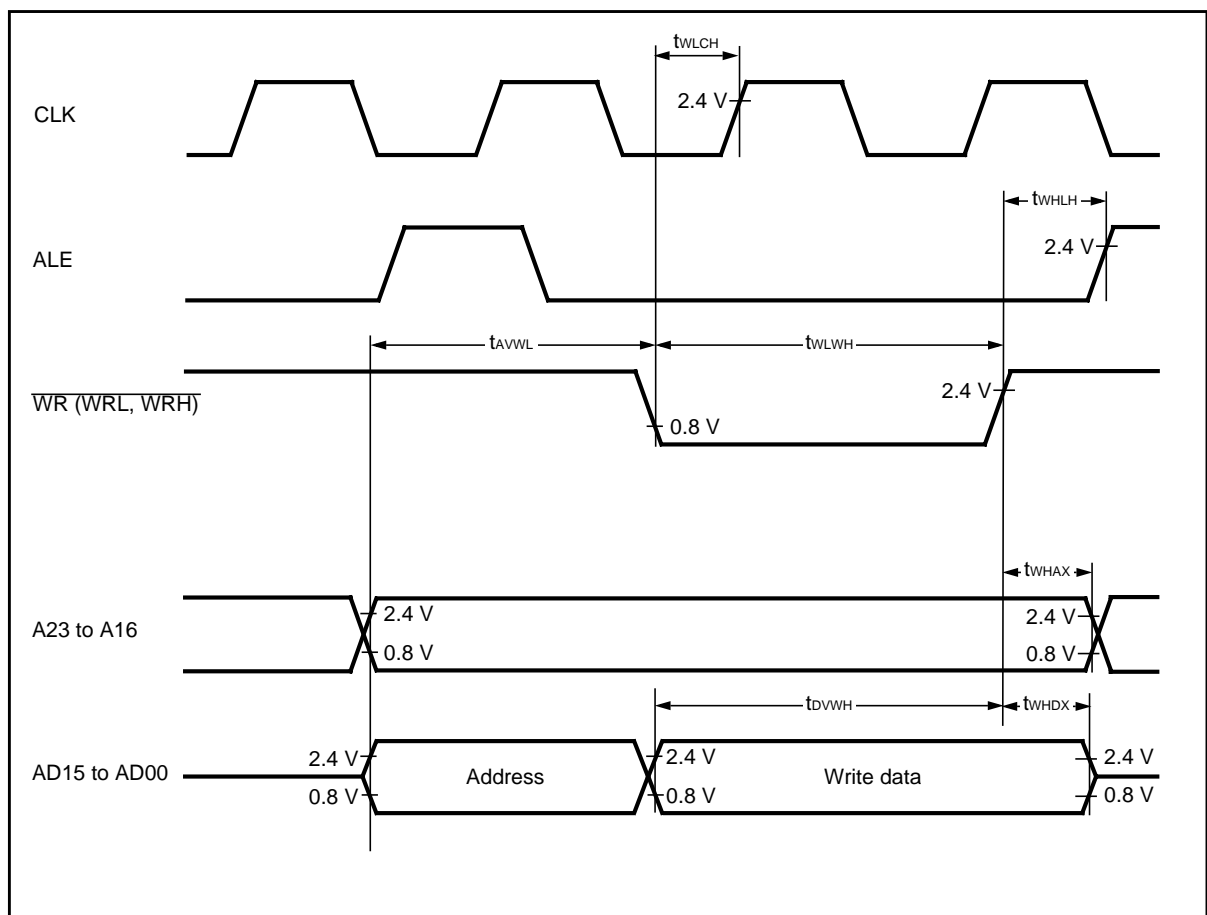

Figure 14.7 Bus Timing (Write)

14.7 External Bus Ready Input Timing

($T_A = -40$ to $+85^\circ\text{C}$, $V_{CC} = 4.5$ to 5.5 V, $V_{SS} = 0$ V)

Parameter	Symbol	Pin	Test Condition	Rated Value		Units	Remarks
				Min.	Max.		
RDY setup time	t_{RYHS}	RDY	—	45	—	ns	
RDY hold time	t_{RYHH}	RDY		0	—	ns	

Note: If the RDY setup time is insufficient, use the auto-ready function.

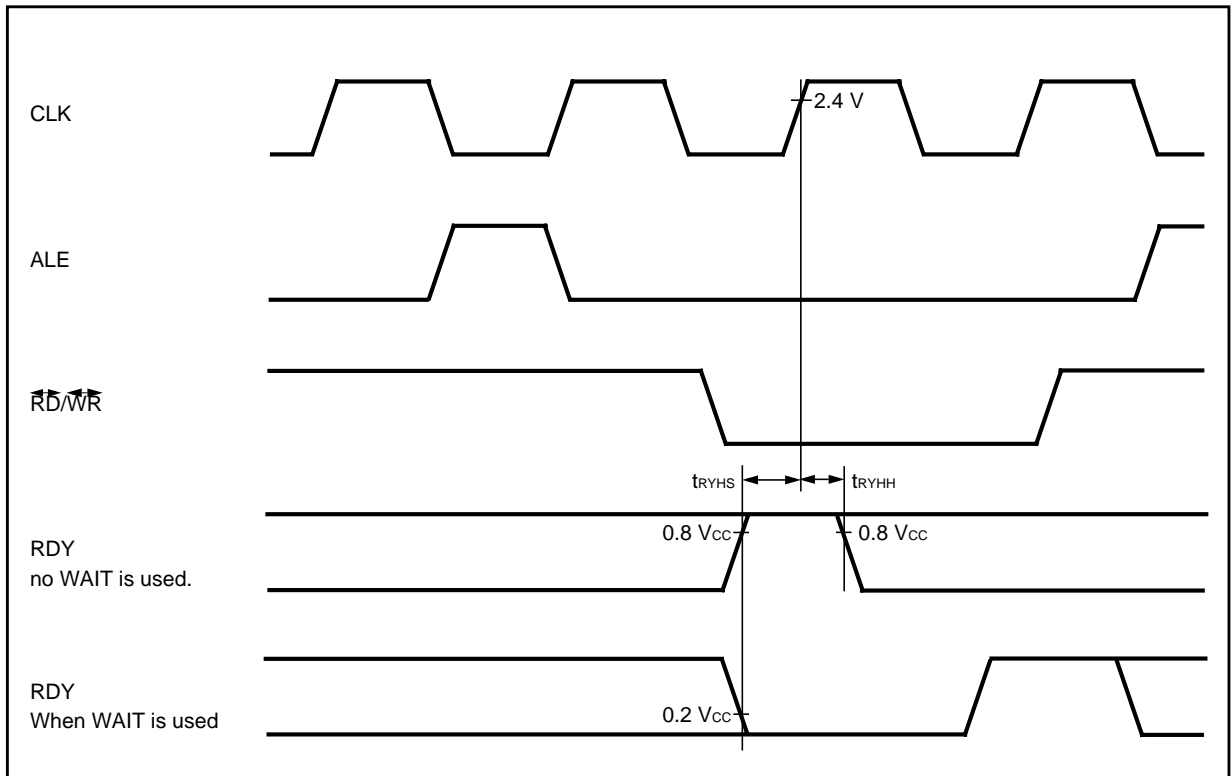

Figure 14.8 Ready Input Timing

MB90495 Series

14.8 External Bus Hold Timing

($T_A = -40$ to $+85^\circ\text{C}$, $V_{CC} = 4.5$ to 5.5 V, $V_{SS} = 0$ V)

Parameter	Symbol	Pin	Test Condition	Rated Value		Units	Remarks
				Min.	Max.		
Pin floating \Rightarrow HAK \downarrow time	t_{XHAL}	HAK	—	30	t_{CP}	ns	
HAK \uparrow time \Rightarrow Pin valid time	t_{HAHV}	HAK		t_{CP}	$2 t_{CP}$	ns	

Note: There is more than 1 cycle from when HRQ reads in until the HAK is changed.

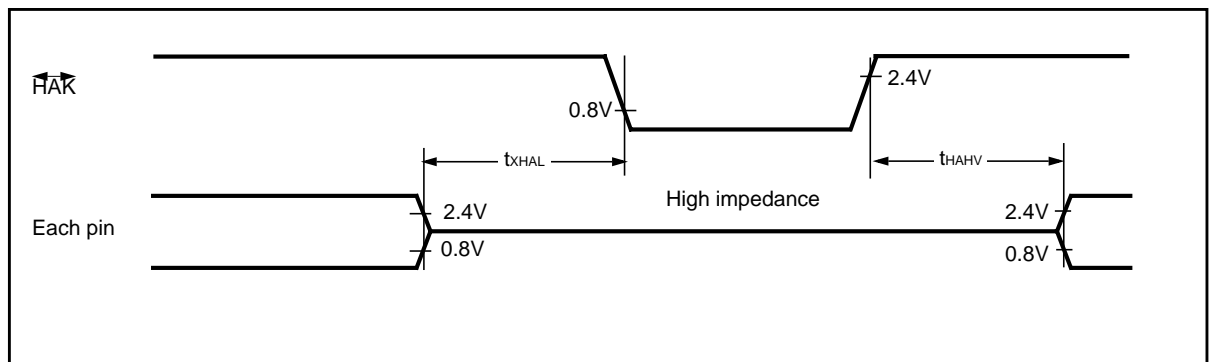

Figure 14.9 Hold Timing

14.9 UART1 Timing

(T_A = -40 to +85°C, V_{CC} = 4.5 to 5.5 V, V_{SS} = 0 V)

Parameter	Symbol	Pin Symbol	Test Condition	Rated Value		Units	Remarks
				Min.	Max.		
Serial clock cycle time	t _{SCYC}	SCK1	Internal clock operation output pins are C _L = 80 pF + 1 TTL.	8 t _{CP}	—	ns	
SCK ↓ ⇒ SOT delay time	t _{SLOV}	SCK1, SOT1		-80	80	ns	
Valid SIN ⇒ SCK ↑	t _{IVSH}	SCK1, SIN1		100	—	ns	
SCK ↑ ⇒ Valid SIN hold time	t _{SHIX}	SCK1, SIN1		60	—	ns	
Serial clock "H" pulse width	t _{SHSL}	SCK1	External clock operation output pins are C _L = 80 pF + 1 TTL.	4 t _{CP}	—	ns	
Serial clock "L" pulse width	t _{LSLH}	SCK1		4 t _{CP}	—	ns	
SCK ↓ ⇒ SOT delay time	t _{SLOV}	SCK1, SOT1		—	150	ns	
Valid SIN ⇒ SCK ↑	t _{IVSH}	SCK1, SIN1		60	—	ns	
SCK ↑ ⇒ Valid SIN hold time	t _{SHIX}	SCK1, SIN1		60	—	ns	

Notes:

1. AC characteristic in CLK synchronized mode.
2. C_L is load capacity value of pins when testing.
3. t_{CP} is the machine cycle (Unit: ns).

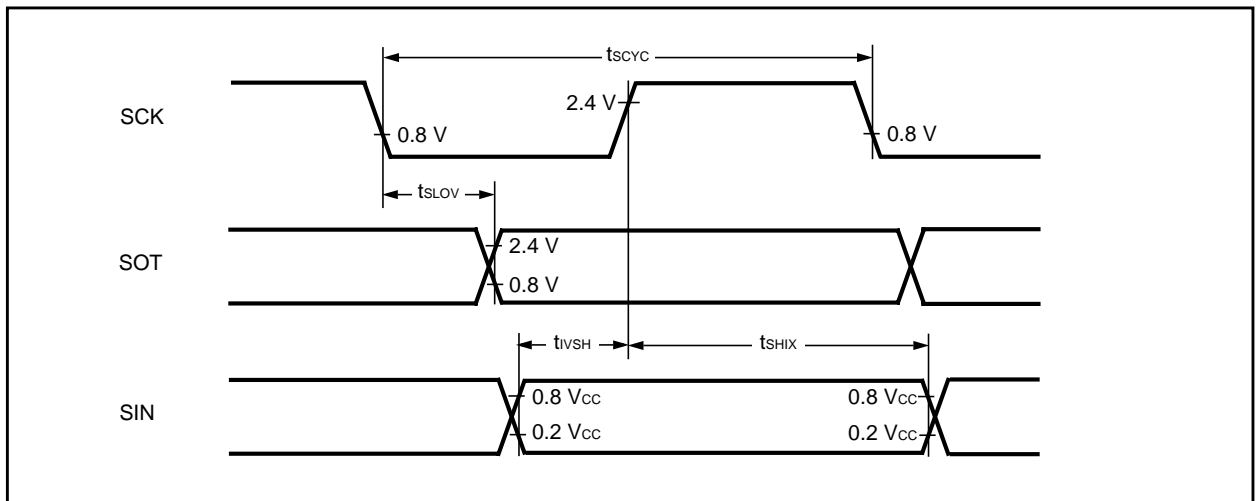

Figure 14.10 Internal Shift Clock Mode

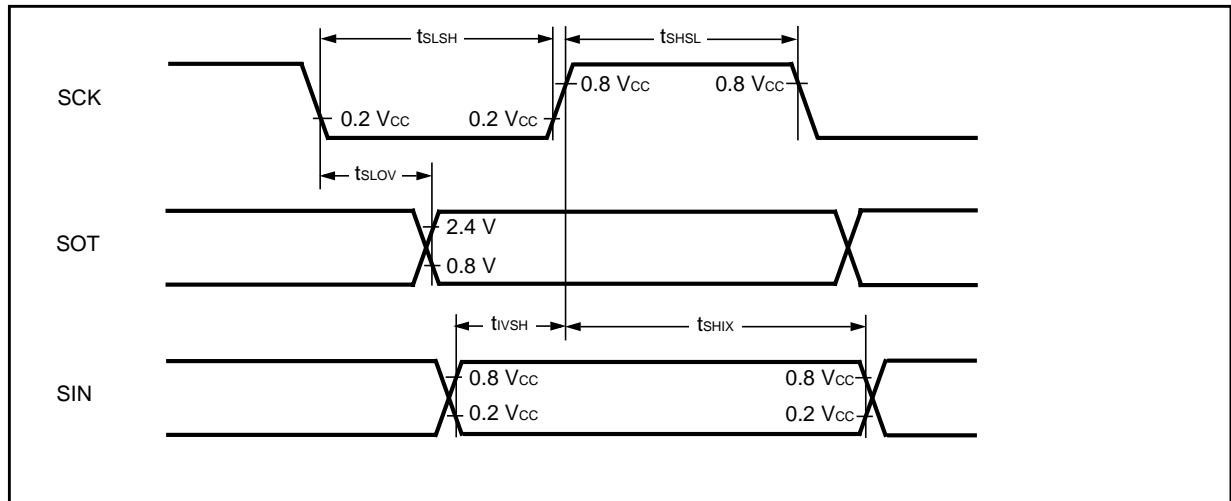

Figure 14.11 External Shift Clock Mode

14.10 Timer Related Resource Input Timing

($T_A = -40$ to $+85^\circ\text{C}$, $V_{CC} = 4.5$ to 5.5 V, $V_{SS} = 0$ V)

Parameter	Symbol	Pin	Test Condition	Rated Value		Unit	Remarks
				Min.	Max.		
Input pulse width	t_{IWH}	TIN0, TIN1	—	4 t_{CP}	—	ns	
	t_{IWL}	IN0 to IN3					

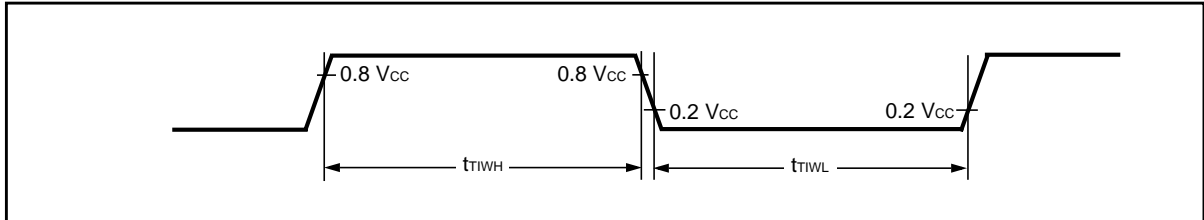

Figure 14.12 Timer Input Timing

MB90495 Series

14.11 Timer Related Resource Output Timing

($T_A = -40$ to $+85^\circ\text{C}$, $V_{CC} = 4.5$ to 5.5 V , $V_{SS} = 0\text{ V}$)

Parameter	Symbol	Pin	Test Condition	Rated Value		Units	Remarks
				Min.	Max.		
CLK \uparrow \Rightarrow T _{OUT} change time	t _{ro}	TOT0 to TOT1, PPG0 to PPG3	—	30	—	ns	

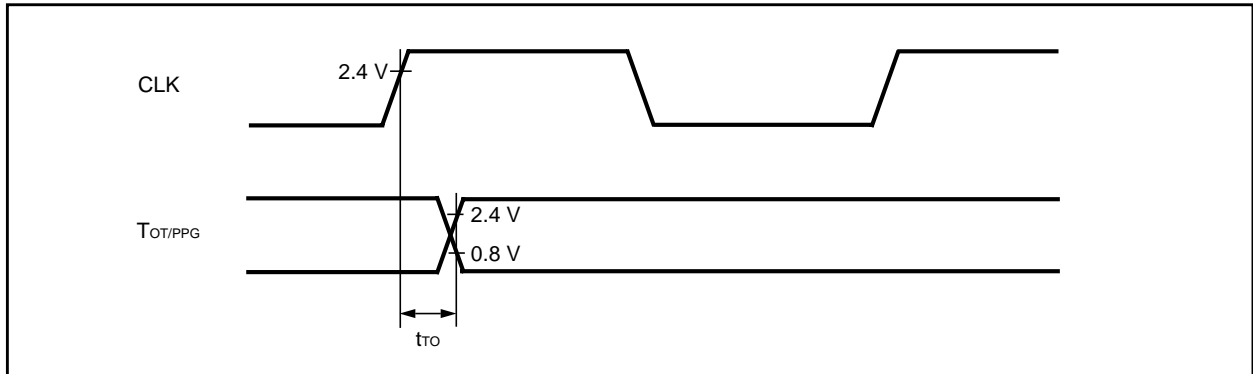

Figure 14.13 Timer Output Timing

14.12 External Trigger Input Timing

($T_A = -40$ to $+85^\circ\text{C}$, $V_{CC} = 4.5$ to 5.5 V, $V_{SS} = 0$ V)

Parameter	Symbol	Pin	Test Condition	Rated Value		Units	Remarks
				Min.	Max.		
Input pulse width	t_{TRGH} t_{TRGL}	INT0 to INT7, ADTG	—	5 t_{CP}	—	ns	

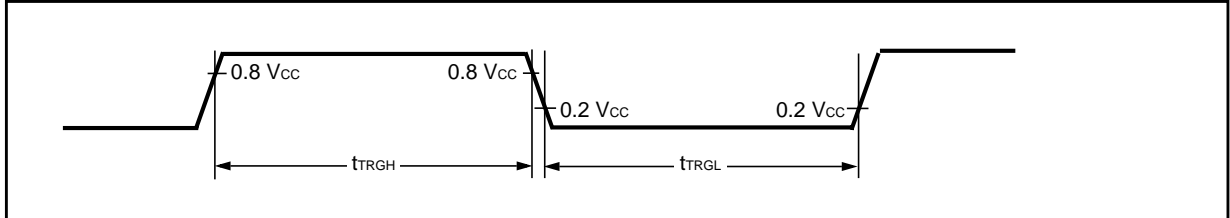

Figure 14.14 External Trigger Input Timing

MB90495 Series

14.13 A/D Converter

($T_A = -40$ to $+85^\circ\text{C}$, $3.0\text{ V} \leq \text{AVR} - \text{AVSS}$, $V_{CC} = \text{AVCC} = 5.0\text{ V}$ 10%, $V_{SS} = \text{AVSS} = 0\text{ V}$)

Parameter	Symbol	Pin	Rated Value			Units	Remarks
			Min.	Typ.	Max.		
Resolution	—	—	—	—	10	bit	
Conversion error	—	—	—	—	5.0	LSB	
Nonlinearity error	—	—	—	—	2.5	LSB	
Differential nonlinearity error	—	—	—	—	1.9	LSB	
Zero reading voltage	V_{OT}	AN0 to AN7	$\text{AVSS} - 3.5$	$\text{AVSS} + 0.5$	$\text{AVSS} + 4.5$	LSB	1 LSB = AVR/1024
Full scale reading voltage	V_{FST}	AN0 to AN7	$\text{AVR} - 6.5$	$\text{AVR} - 1.5$	$\text{AVR} + 1.5$	LSB	
Conversion time	—	—	—	176 t_{CP}	—	ns	
Sampling time	—	—	—	64 t_{CP}	—	ns	
Analog port input current	I_{AIN}	AN0 to AN7	—	—	10	μA	
Analog input voltage range	V_{AIN}	AN0 to AN7	AVSS	—	AVR	V	
Reference voltage range	—	AVR	$\text{AVSS} + 2.7$	—	AVCC	V	
Power supply current	I_A	AVCC	—	5	—	mA	
	I_{AH}	AVCC	—	—	5	μA	*1
Reference voltage current	I_R	AVR	200	400	600	μA	
	I_{RH}	AVR	—	—	5	μA	*1
Offset between input channels	—	AN0 to AN7	—	—	4	LSB	

*1: When not operating A/D converter, this is the current ($V_{CC} = \text{AVCC} = \text{AVR} = 5.0\text{ V}$) when the CPU is stopped.

Terminology:

- Conversion error : Absolute maximum conversion deviation with respect to the theoretical conversion line.
- Nonlinearity : Relative maximum conversion deviation with respect to the theoretical conversion line connecting to the device-unique zero reading voltage and full-scale reading voltage.
- Differential non-linearity : Maximum conversion deviation in any two adjacent reading voltages with respect to the theoretical LSB conversion step.
- Zero-reading voltage : Input voltage which results in the minimum conversion value.
- Full-scale reading voltage : Input voltage which results in the maximum conversion value.

Notes:

- The accuracy gets worse as $\text{AVR} - \text{AVSS}$ becomes smaller.
- Analog input external circuit output impedance should use the following conditions:
External circuit output impedance less than $15\text{ k}\Omega$
- If the external circuit output impedance is too high, there may be insufficient time for sampling of the analog voltage.

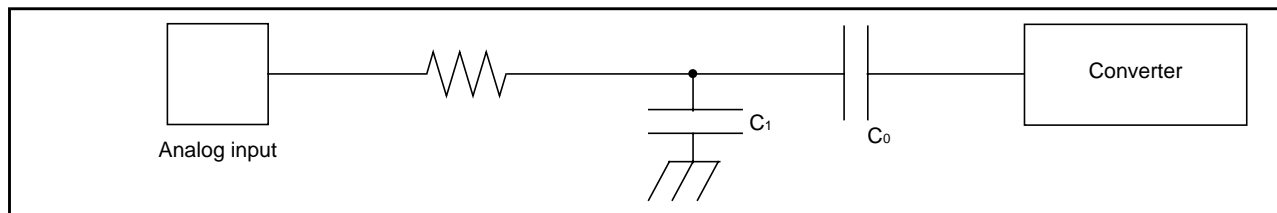
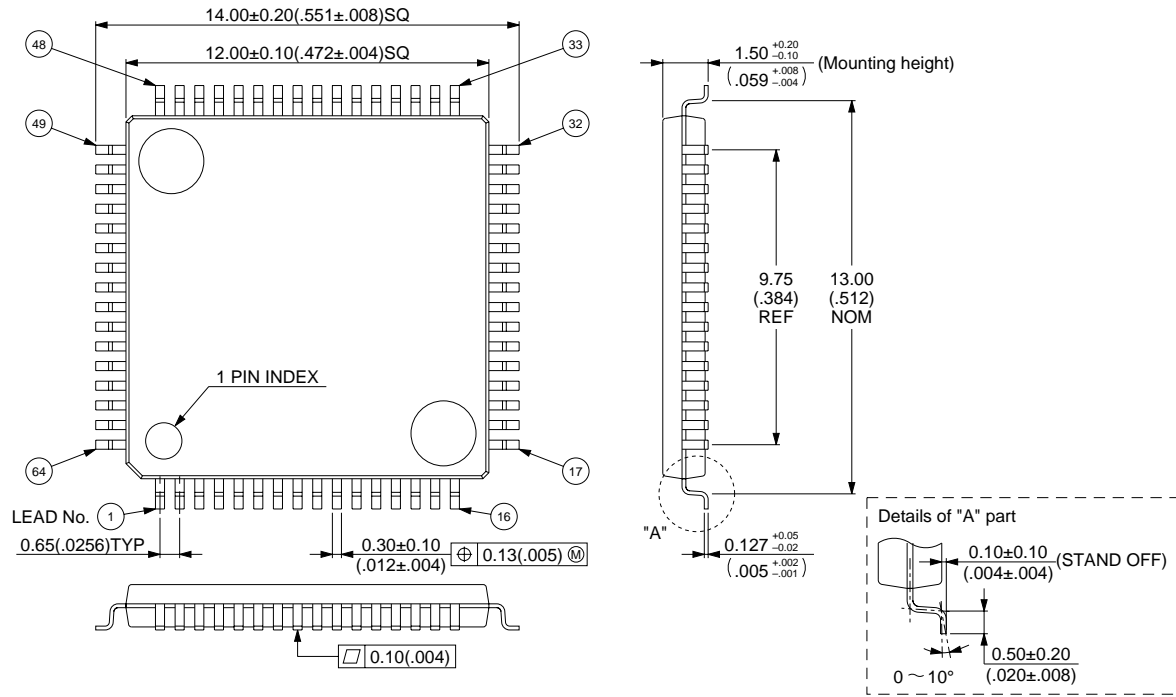

Figure 14.15 Analog Input pin

15. PACKAGE DIMENSIONS



© 1994 FUJITSU LIMITED F64018S-1C-2

Figure 15.1 Package Code: FPT-64P-M09

MB90495 Series

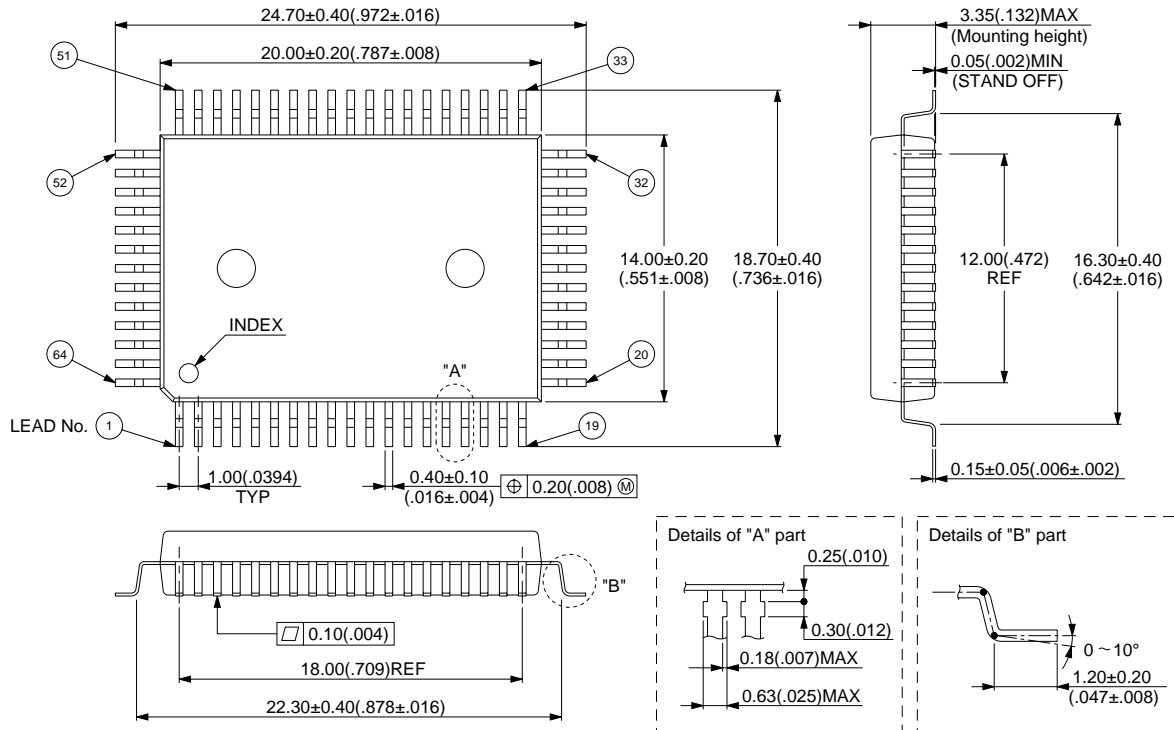

© 1994 FUJITSU LIMITED F64013S-3C-2

Figure 15.2 Package Code FPT-64P-M06