

Universal Control Unit UC-1s

UC-1s 通用润滑系统控制器

User's Manual

用户操作指导手册

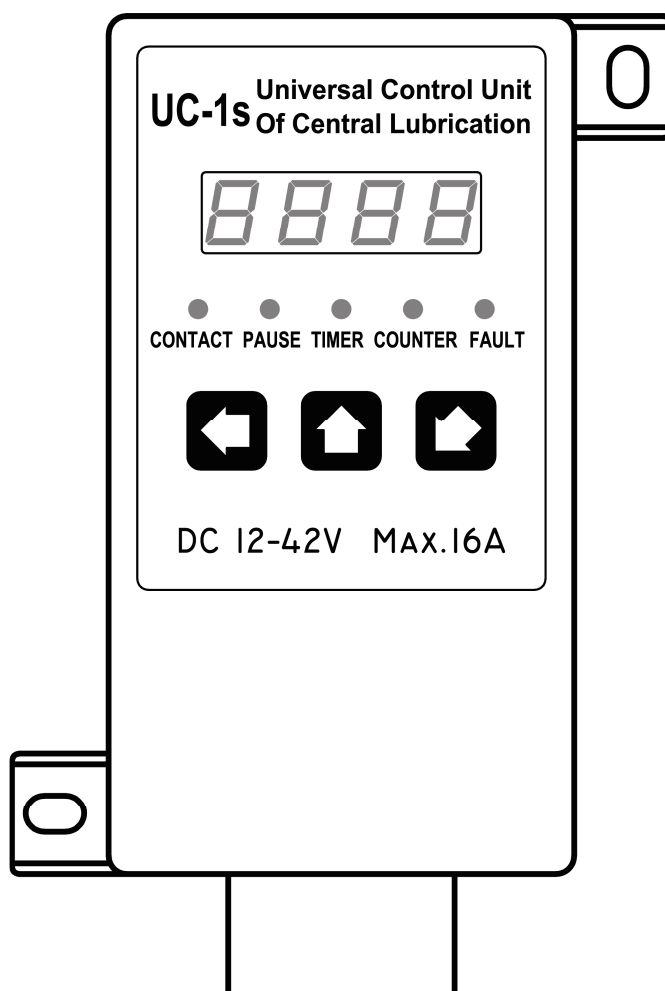

Suzhou Leetern Industry Control Department

May. 2008

Universal Control Unit UC-1s is designed for controlling and monitoring of centralized lubrication systems of engineering machinery, chassis and lubrication stations. UC-1s stores configuration data and parameters in EEPROM, which made UC-1s can store data safely for long period without backup power supply.

The control unit uses LED digital display and LED indicator lights to display information, which are convenient for user's operation.

Factory settings on UC-1s are as followings:

Pause mode:	timer
Pause time:	480 min (8 h)
Contact control mode:	timer
Contact time:	120 s (2 min)
System monitoring:	P ressure S witch (built-in)

Without our written permission, any forms of translation, excerpt, copy, print and reproduce of this USER MANUAL and its content is prohibited. We reserve all rights to this USER MANUAL. We reserve the right to revise it without prior notice.

Manufacturer : Suzhou Leetern Industrial Control Department
Address: Rm.102, Building 8, No. 22, Xiao Shi Jia Nong, Suzhou, China
Technical Support Fax: +86-512-68661838
Technical Support Email Box: support@leetern.com
Website: <http://www.leetern.com>

Contents

Safety Warning!

1. Installation

- 1.1 Installation dimensions
- 1.2 Electrical connection

2. Display and control panel

- 2.1 LED digital display
- 2.2 LED signal lights
- 2.3 Film Keys
- 2.4 SL signal lights

3. Operation guidance

- 3.1 Display operation
- 3.2 Programming operation

4. Operating modes

- 4.1 Timer operation
- 4.2 Counter operation
- 4.3 Combination operation
- 4.4 Operation with system monitoring
- 4.6 Power-off protection function

5. Faults

- 5.1 Fault display
- 5.2 Fault message clearance
- 5.3 Pressure switch inspection

6. Technical data

Safety Warning!

Universal Control Unit UC-1s is designed and manufactured not only in conformity with the generally engineering standards, industrial safety and accident prevention regulations, but also in accordance with some relevant generally industrial technical acceptance standards.

Although this unit complies with relevant safety technical requirements, the use of the unit may still entail dangers leading to personal injury of the user or third parties or damage to property. Therefore, the unit must be used when it is in perfect technical condition. And the operation must strictly comply with operation manual. Errors that may affect safety must be rectified immediately.

The unit is designed for controlling and monitoring centralized lubrication systems. The user himself shall be liable for any damage caused by improper use.

Potential electrical dangers

This unit must be connected to the power supply only by trained qualified personnel in accordance with the local electric technical regulations. Improper connection may lead to serious personal injury.

This unit is designed to use in battery-powered on-board electric system of chassis, engineering equipment and lubrication station. When it is used for any other purposes, all safety regulations should be complied with.

Qualified personnel

Qualified person means person trained, assigned and instructed by the operator of the equipment concerned. They are familiar with relevant safety rules or regulations and have certain knowledge and skills of safety.

They are entitled to carry out the activities required in a given case and will be able to recognize and avoid possibly existing dangers.

1. Installation

Universal Control Unit UC-1s is **not** designed to work in open-air; it has to be installed in an enclosed compartment to protect it from environmental influences.

If the control unit is installed at an inaccessible position, it is advisable to install additional signal lights and pushbutton in operation room. So that the operating situation of the control unit can be remote monitored.

1.1 Installation dimension

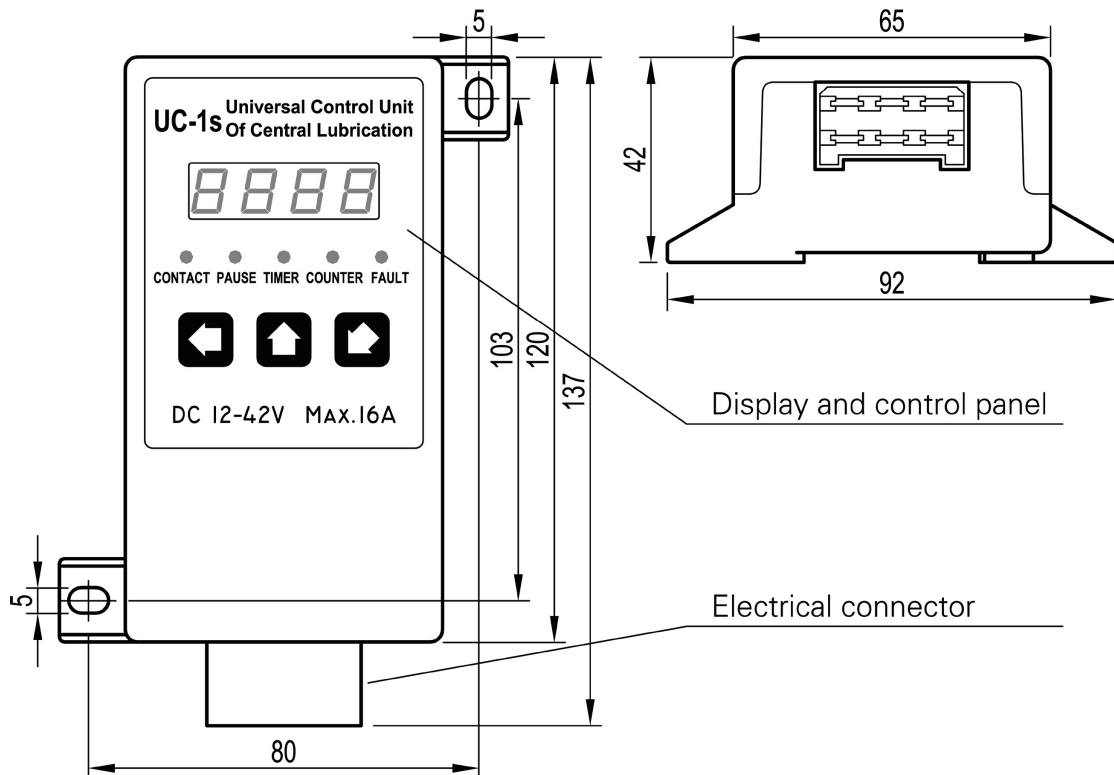

1.2 Electrical connection

PS	External P ressure S witch
15	Positive pole of power supply
+M	Pump motor
+SL	External S ignal L ight
DK / MK	External pushbutton (timer operation) Signal input (counter operation)
31	Ground
Z	Start-switch

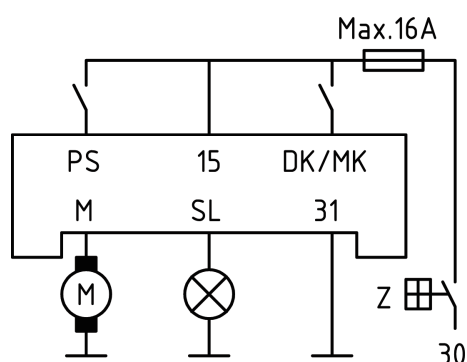

Terminal connection diagram

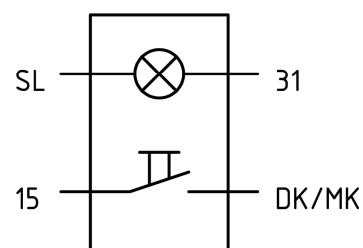

Electrical connection diagram of DK switch and SL lights.

Note: Please make sure that the system voltage matches the voltage claimed on the control unit. The fluctuation of supply voltage should be within **10V~45V**. Lower or higher than the voltage limit will permanently damage the control unit.

If the lowest required voltage is not guaranteed, please purchase Low Voltage Protector to protect the control unit against low voltage.

2. Display and control panel

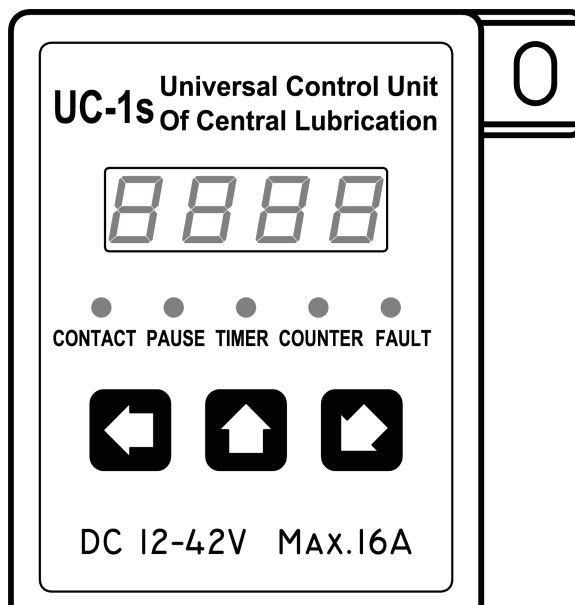

Film panel protects UC-1s from humidity and dust.

Please use soft cloth with warm water or neutral detergent to clean the film panel. Organic solvent is prohibited because the film is made in organic material.

Do not use sharp tools/ object to touch the panel.

Don't take off the protective film until the final installation is fully completed.

2.1 LED digital display



LED digital display shows operating status and parameters.

LED is deactivated normally. To activate it, press key , LED then start to display current status and programmed parameters. †

2.2 LED signal lights

 **PAUSE** PAUSE: Pause signal light.

LED "PAUSE" is on: Power is supplied to pump and control unit. System is in PAUSE status. Parameters relate to PAUSE can be altered under programming mode.

Signal light is "flashing" means the signal light flashes with a frequency of light up for 0.5s and off for 0.5s; Signal lights "flash quickly" means the lights flash with a frequency of less than 0.5s.

 **CONTACT** CONTACT : Lubricating signal light

LED “CONTACT” is on: Power is supplied to pump and control unit. System is in CONTACT status. (Pump motor is running)
Under programming mode, parameters relate to CONTACT can be altered when LED “CONTACT” is on.

 **TIMER** TIMER : signal light of timer control mode

Signal light “TIMER” is on: System is now under TIMER control mode.
In programming mode, user can change control mode when signal light “TIMER” flashes.

 **COUNTER** COUNTER : signal light for counter control mode

Signal light “COUNTER” is on: system is now under COUNTER control mode.
In programming mode, user can change control mode when signal light “COUNTER” flashes.

 **FAULT** FAULT : fault signal light

LED “FAULT” flashes quickly: Control unit is in fault.
Press key  , then fault message will be displayed on LED display screen.

2.3 Film keys

 Scroll up key

Activate display in display mode.
Increase the displayed value at cursor position (figure blinking position) by 1 with key  in programming mode.
If the figure is already “9”, then it returns to “0”.



Scroll left key/DK key

To move left the LED digital cursor in programming mode. If the cursor is already at the leftmost position, then by operating key  once, cursor returns back to the rightmost position.

In PAUSE period, press key  once will initiate an intermediate lubrication cycle;

In FAULT status, press key  once to clear fault message and get system back to normal lubrication cycle.



SET key

Activate programming mode. Confirm options or parameters.

Note: Control unit UC-1s can get into programming operation only under non-fault state. If lubrication system is under fault state, the fault should be cleared first.

2.4 External Signal Light SL

If an external signal light SL has been installed, SL will flash for 3 seconds after the start-switch is started.

Note: Control unit needs a certain time to save the operating parameters at the point of power-down so that the lubrication task of the control unit could be continued after the break. **The interval of the power-down and the next power-on should not be shorter than 3 seconds. Otherwise, control unit may not start properly, and SL will not flash.**

Whenever the control unit is performing the lubrication task, light “SL” will be on, indicating the status of lubricating; If the detecting system detects any faults during operation, light “SL” will be flash to remind user that the lubrication system is in fault.

† Under display mode or programming mode, if no key operations for more than 2 minutes, LED display turns off automatically and quit current operation.

3. Operation guidance

Briefly press key  to activate display. LED display begins to show system's preset parameters and current values. LED signal lights are used to show control unit's working status normally.

Press and hold  to activate programming. Please refer to chapter 3.2: «programming» for details.

If PAUSE control mode is TIMER, the figure displayed on screen is in “minute”; If CONTACT control mode is TIMER, then the figure is in “second”. If control mode is COUNTER, the figure displayed on screen is the signal numbers that sensor sent to UC-1s.

3.1 Display operation

1. Briefly press  to show current status, control mode and remain values of UC-1s.

Example: LED “PAUSE” and “TIMER” are on; current status is “PAUSE” under timer control mode. And remain value is 162 seconds.

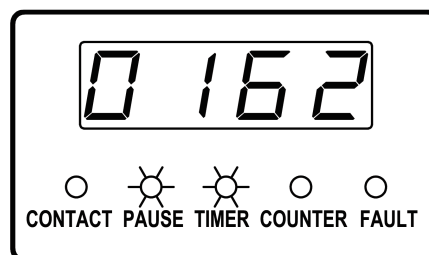

2. Press , figure on LED screen begins to flash. This means it is preset PAUSE control parameter.

Example: Preset PAUSE time is 480s.

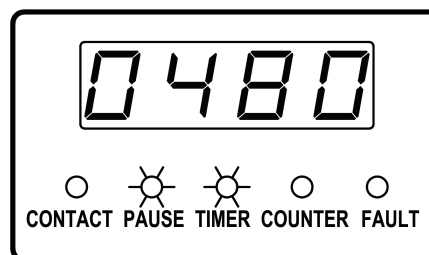

3. Press , to show the other status's control mode and remain value.

Example: LED “TIMER” is on means CONTACT is in TIMER mode; remain value shows “----”, because system is now in PAUSE period, there is no remaining value of CONTACT.

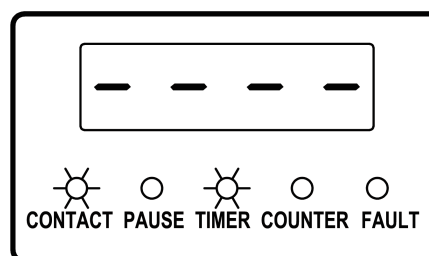

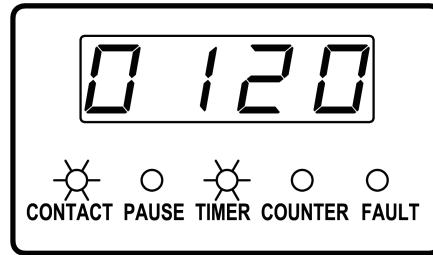

4. Press , figure on LED screen begins to flash. This means it is preset control parameter for another status (CONTACT).

Example: Preset CONTACT time is 120s.

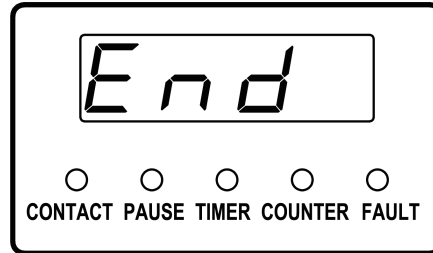

5. Press , LED display shows "End". Display process is over.



6. Press , LED display goes off. UC-1s quits display operation.

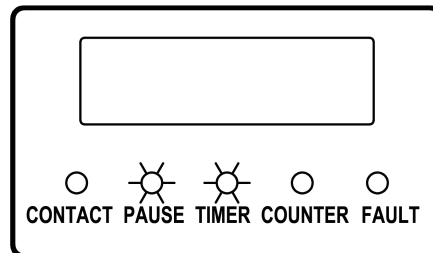

3.2 Programming

1. Press key  longer than 2 seconds, LED "PAUSE" will be on, at the same time LED "TIMER" or "COUNTER" is flashing to indicate the programmed control mode of PAUSE.

Example: TIMER (Factory setting)

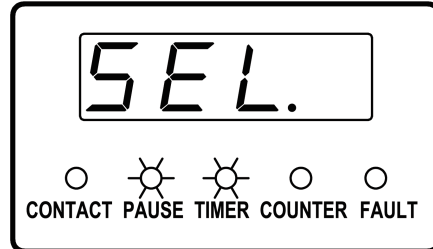

2. User may use key  to change control mode, then the relevant LED "TIMER" or "COUNTER" will be flashing after the change.

Example: Change to COUNTER

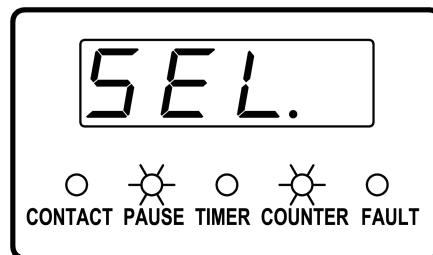

3. Press key  to confirm the control mode. LED screen then begin to display preset PAUSE control parameter.

Example: 480min (Factory setting)

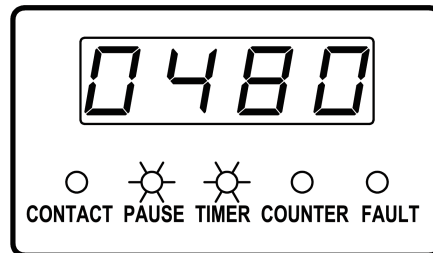

4. PAUSE control parameter can be modified with keys  and  .

Example: 540min (9 hours)

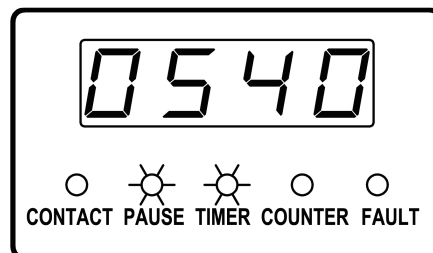

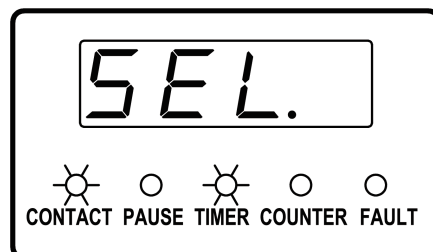

5. Press key  to confirm the new PAUSE control parameter. LED "PAUSE" goes off. LED "CONTACT" then lights up to show preset CONTACT control mode.

Example: TIMER (Factory setting)



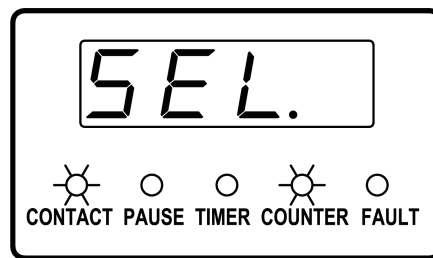

6. User may use key  to change control mode of CONTACT, then the relevant LED "TIMER" or "COUNTER" will be flashing after the change.
Example: Change to CONTER mode

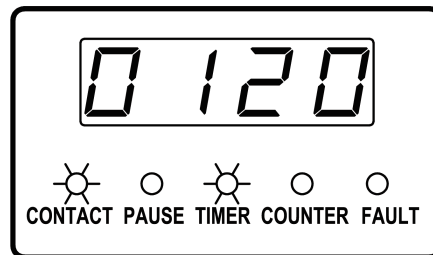

7. Press  to confirm the new control mode of CONTACT, LED screen then shows preset CONTACT parameter
Example: 120s (Factory setting)



8. CONTACT value can be modified with keys  and .
Example: 180s (3minutes)

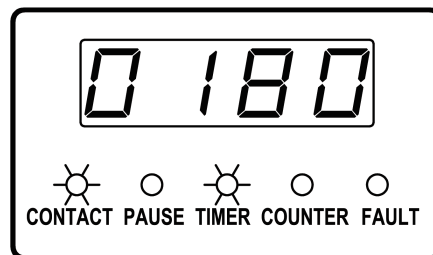

9. Press  to confirm the new CONTACT parameter.
LED screen then displays "End" that means programming operation is over.

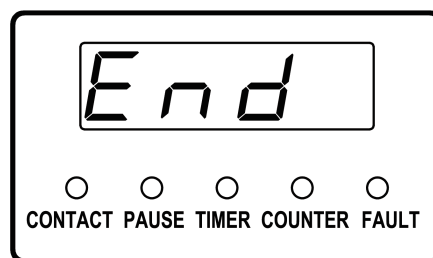

10. Press key , LED display goes off. UC-1s quit programming operation. All the programmed new values and control modes are saved permanently till next program change.

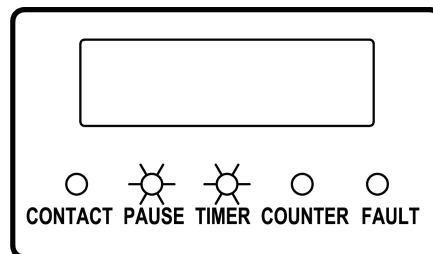

4. Operating modes

4.1 Timer operation

Set "TIMER" for both PAUSE and CONTACT.

The control of the lubrication cycle takes place based on the values preset for PAUSE and CONTACT times. It carries out the operation cycle of "PAUSE - CONTACT"

Press  or external DK button, an intermediate lubrication cycle is activated OR the displayed fault message is cleared. External DK button can be connected to the terminal DK/MK

4.2 Counter operation (Pause depends on external impulses)

Set "Counter" for PAUSE and "Timer" for CONTACT.

Connect an external impulse transmitter to the terminal DK/MK.

PAUSE: Display and program values in impulses.

CONTACT: Display and program values in time.

4.3 Combination operation(Pump running is controlled by external impulse)

PAUSE: Display and program values in impulses or time.

CONTACT: Display and program values in impulses.

Users may combine "COUNTER MODE" of pause with "COUNTER MODE" of contact, or "TIMER MODE" of pause with "COUNTER MODE" of contact.

4.4 System monitoring

Control unit UC-1s is designed with built-in Pressure Switch monitoring function. It uses pressure switch to monitor the pressure formation situation in the main oil line. If Pressure Switch detects no pressure is formed in the main oil line during CONTACT period, fault will be automatically detected and displayed.

If lubrication system does not need Pressure monitoring, please short connect PS input terminal (pressure switch signal) and 15 input terminal (positive pole of power supply). In such mode, lubrication cycle only carries out lubrication task according to programmed PAUSE and CONTACT parameters, and will not monitor errors.

4.5 Power-off protection function

The control unit has power-off protection function. When power is cut off, the control unit auto stores operating status, remain values and relevant system data at the point of power-off. When next electrify starts, the control unit will continue carrying out operation from last point of power-off.

The control unit stores operating status and values in EEPROM. The data can reliable be stored for over 10 years.

5. Faults

When the control unit detects system faults, signal light “FAULT” on the panel will be flashing quickly. If an external Signal Light has been installed, light “SL” will be also flashing to remind user the lubrication system is in fault. Meanwhile, the control unit stops normal operation and wait for user to handle the faults. User may check the detailed cause of the fault via display and control panel.

5.1 Display faults

Briefly press  to start the display of fault messages. The meaning of the display are as followings: :



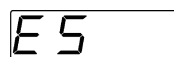

No signal is received from pressure switch during pump running time.



The control unit itself has error inside. If such situation occurs, get the control unit power off, then get it power on 1 min later. If error still exists, please contact the manufacturer.

5.2 Clear fault messages

Press key  or external DK button to clear fault messages, and to start a normal lubrication cycle.

Please note:  or external DK button must be used after determining and correcting the faults. The user himself is liable for any damages caused by operating the equipment without lubrication.

5.3 Pressure switch inspection

If external pressure switch is used, normal operation will automatically stop when no signal from the pressure switch is received during the pump running. And a fault message is displayed.

6. Technical Data

Voltage of power supply :	12V~42V
Type of protection :	IP40
Max. Load output M :	16A
SL output :	5W
Data storage :	No limitation
Operation temperature :	-35℃~75℃
Storage temperature :	-45℃~85℃
Recommended fuse specification :	10A
Installation dimensions L × W × H:	137mm × 92mm × 42mm
Single Mass:	200g
Programmable contact time:	1s~9999s
Programmable pause time:	1min~9999min
Programmable impulses :	1~9999

UC-1s 通用润滑系统控制器是专门为集中润滑控制设计的控制器，适用于工程机械、底盘集中润滑和润滑站的控制。控制器的控制方式和控制参数保存在 **EEPROM** 内，不需要后备电源支持就可以长期可靠存储。

控制器采用 **LED** 数码显示器和 **LED** 指示灯显示信息，方便用户操作使用。

UC-1s 通用润滑系统控制器出厂设置如下：

间歇控制方式：	定时器控制
间歇时间：	480 分钟(8 小时)
润滑控制方式：	定时器控制
润滑时间：	120 秒(2 分钟)
系统监控方式：	压力开关监控(内置)

未经书面许可，禁止以任何形式翻译、摘录、复制本手册内容。本司保留对手册的所有权，有权在未预先通知的情况下修订手册内容

产品制造商： 苏州力天工业控制事业部

办公地址： 苏州市小施家弄 22 号 8 号楼 102 室

技术支援电话： 0512-68661838

技术支援邮箱： support@leetern.com

互联网网站： <http://www.leetern.com>

目 录

安全警告!

安装

- 1.1 外形尺寸
- 1.2 电气接线

2. 显示控制面板

- 2.1 LED 数码显示器
- 2.2 LED 指示灯
- 2.3 薄膜按键
- 2.4 SL 指示灯

3. 操作指导

- 3.1 显示操作
- 3.2 编程操作

4. 工作模式

- 4.1 定时工作方式
- 4.2 计数工作方式
- 4.3 组合工作方式
- 4.4 系统监控
- 4.5 断电保护功能

5. 故障监测和处理

- 5.1 故障显示
- 5.2 清除故障信号

5.3 压力开关检测

6. 技术参数

安全警告！

UC-1s 通用润滑控制器(以下简称本产品)按照通用工程技术标准设计和制造。在符合相应的工业安全和事故防范条例的同时，还符合相应的一般工业技术验收标准。

虽然本产品符合相应的安全技术条件，但使用中仍然可能会伤害到使用者或第三者或危及其他器材。因此只能安装使用技术状态完全正常的产品并严格遵守操作说明，任何影响安全的故障应立即纠正。

本产品只能用于集中润滑系统的控制与监控。如被用于任何不恰当之处而造成的损害，由当事人自己负责。

潜在的电气危险

本产品只能由经过培训的合格人员，按照国家电气技术规范规定接入电源。不正确的连接将导致人员的重大伤害。

本产品适用于底盘、工程机械及润滑站上，以蓄电池或类似直流电源供电的电气系统。当作其他用途时，必须遵守相应的安全规定。

合格人员

本手册所称合格人员，是指接受过本产品相关培训的人员。他们要熟悉相关的安全标准、规定，具备相应的安全知识和技能。他们能在已知情况下被授予完成需要做的工作，还要能够识别并阻止可能发生的危险。

1. 安装

UC-1s 通用润滑系统控制器**不是**为露天使用设计的，控制器必须安装在封闭隔仓内，以保护控制器不受环境影响。

如果控制器被安装在难于接近的地方，可以在操作室安装指示灯和按钮组合开关，以便远程监控控制器的运转。

1.1 外形尺寸

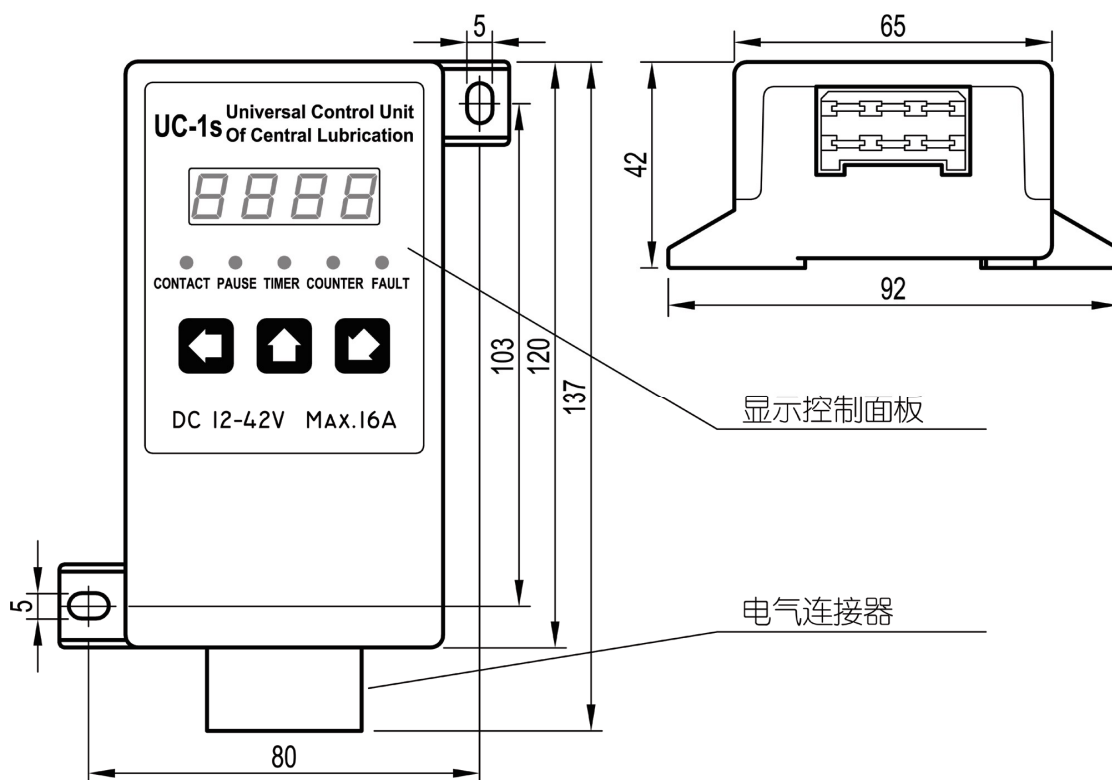

1.2 电气接线

PS	外接压力开关
15	控制器供电正极
+M	泵电机
+SL	外接指示灯
DK / MK	外接按钮开关(定时器控制方式) 计数信号输入(计数器控制方式)
31	接地
Z	启动开关

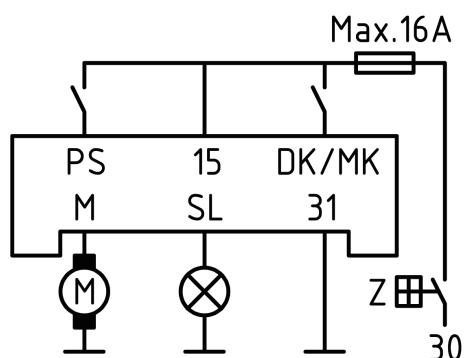

电气连接器接线图

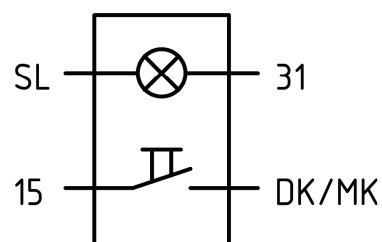

DK 开关和 SL 灯组件接线图

请注意：

安装和使用控制器时，必须保证电源电压与 UC-1s 控制器面板上标称电压一致。电源电压波动不能超过 **10V~45V**，低于或者高过这个电压范围都可能给控制器造成永久性的损害。

如果最低供电电压不能保证在在上述范围，可以订购低压保护器以保护控制器不受过低电压损害。

2. 显示控制面板及其操作

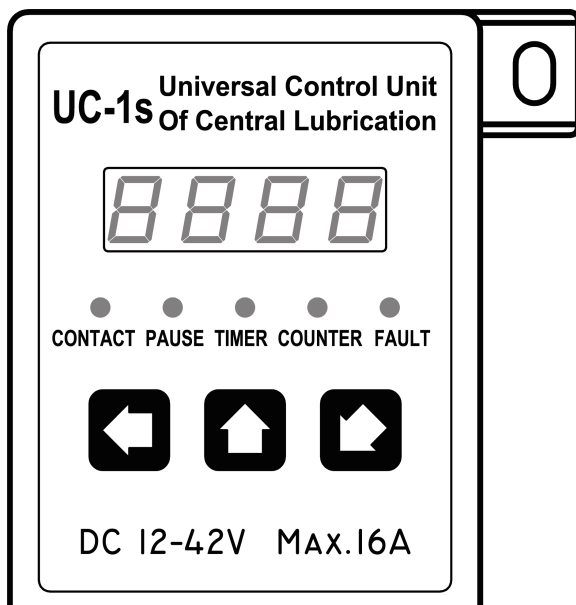

UC-1s 通用润滑系统控制器采用薄膜面板保护控制器不受潮气和污物侵入。

薄膜面板不能用有机溶剂来擦洗。如果想清洁面板，可以用软布蘸中性洗涤剂擦拭。

不能用尖锐的物体刺薄膜面板，以免损坏薄膜面板。控制器在最终安装到安装位置前，请勿揭下保护膜。

2.1 LED 数码显示器



LED 显示器用来显示工作数据和状态

LED 显示器平时是关闭的。要启动显示，只要按下  键，显示器即开始显示当前状态和设定的工作参数。[†]

2.2 LED 指示灯



PAUSE PAUSE：间歇指示灯

PAUSE 灯常亮表示：控制器和泵已经接通电源，系统处于间歇状态。在编程设定时，PAUSE 灯亮表示当前设定项目为间歇相关内容。

本手册中所提到的指示灯常亮，是指指示灯稳定地点亮；指示灯闪亮，是指指示灯以 0.5s 点亮、0.5s 熄灭的频率闪动；指示灯闪烁，是比闪亮更急速的闪动。

 **CONTACT** CONTACT: 润滑指示灯

CONTACT 灯常亮表示:控制器和泵已经接通电源,系统处于润滑状态。(泵电机在运转)。

在编程设定时, CONTACT 灯亮表示当前设定项目为润滑相关内容。

 **TIMER** TIMER: 定时器方式指示灯

TIMER 灯常亮表示:系统当前采用定时器方式控制。

在编程设定时, TIMER 灯闪亮表示:当前可以更改控制方式。

 **COUNTER** COUNTER: 计数器方式指示灯

COUNTER 灯常亮表示:系统当前状态采用计数器方式控制。

在编程设定时, COUNTER 灯闪亮表示:当前可以更改控制方式。

 **FAULT** FAULT: 故障指示灯

FAULT 灯急速闪烁表示:润滑系统发生了故障。

按动  键后,故障信息就显示在 LED 显示器上。

2.3 薄膜按键

 向上滚动键

在显示操作时,启动控制器进入显示操作。

在编程操作时,按动一次  令光标位(即数字闪烁位)数字加 1。如果数字已经为 9,则数字回归为 0。

 向左滚动 / DK 键

在编程操作时,用于向左移动 LED 数码光标。如果光标已经在最左位,

则光标回归到最右位。

在间歇状态下，按一次  ，将启动一次中间润滑；

在故障状态下，按一次  ，清除故障信号并使系统重新进入正常的润滑周期循环。



设置键

启动控制器进入编程设定操作， 确认选项或者参数。

请注意： 控制器只能在润滑系统处于非故障状态下进入编程操作。如果润滑系统在故障状态，必须先排除故障。

2.4 外接指示灯 SL

如果外接了 SL 指示灯，在启动电源开关后，SL 指示灯将闪亮 3 秒钟。

请注意： 控制器断电时需要一定时间保存断电时刻工作参数，以便下次上电时从中断处继续执行润滑任务。因此用户在使用控制器时候，控制器断电与再次上电的时间间隔不能小于 3 秒钟。否则，控制器可能不能正常启动，SL 指示灯就不会闪亮。

当控制器正在执行润滑任务时候，SL 指示灯将被点亮，以指示控制器的润滑状态；如果在工作过程中控制器检测到了故障，SL 指示灯持续闪亮，以提醒用户：润滑系统发生了故障。

† 在显示操作或者编程操作时，如果 2 分钟内没有有效的按键动作，LED 显示器将自动关闭，并退出当前操作。

3. 操作指导

短暂按  键，控制器就启动了显示操作，LED 显示器开始显示系统的设定参数和工作数据。LED 指示灯用来在平时显示控制器的状态。

编程操作长按  键来启动，具体请见 3.2 节：《编程操作》。

如果间歇的控制方式为定时器控制，显示器上所显示数字的单位隐含为分钟；如果润滑的控制方式为定时器控制，显示器上所显示数字的单位隐含为秒。如果润滑控制方式或间歇控制方式为计数器控制，显示器上所显示数字的单位为隐含为次数。

3.1 显示操作

第 1 步：短暂按  键，开始显示控制器的当前状态、控制方式和剩余数值

例如：PAUSE 灯亮-当前为间歇状态，TIME 灯亮-间歇采用定时器控制，剩余 162 秒

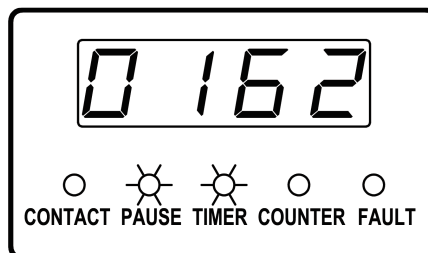

第 2 步：按  键，LED 显示器显示的数字开始闪烁，表示这是预设的间歇控制参数

例如：预设的间歇时间为 480 秒

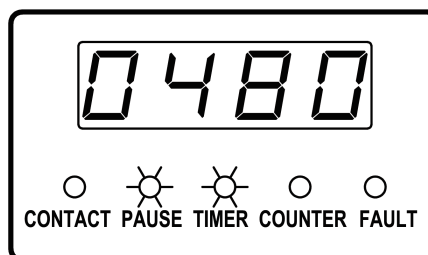

第 3 步：按  键，显示控制器另一个状态的控制方式和剩余数值

例如：TIME 灯亮，表示润滑采用定时器控制；剩余数值为 - - - -，表示无效

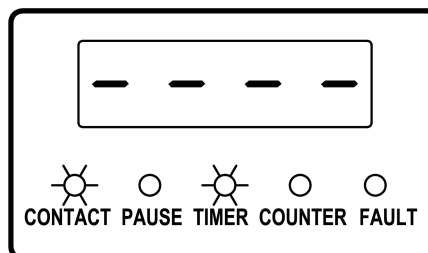

第 4 步：按  键，LED 显示器显示的数字开始闪烁，表示这是预设的另一状态（润滑）的控制参数

例如：预设的润滑时间为 120 秒

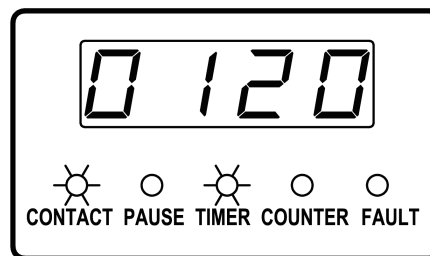

第 5 步：按  键，LED 显示器 End 字样，表示显示过程结束

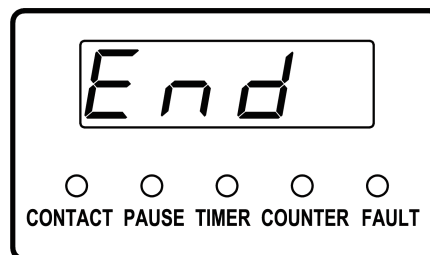

第 6 步：按  键，LED 显示器关闭，退出显示操作状态

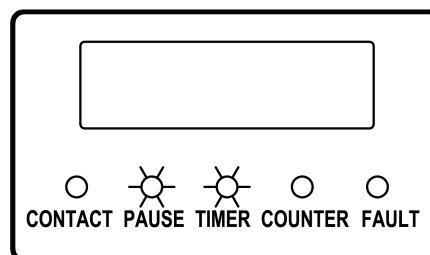

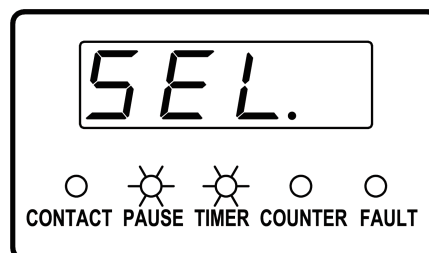

3.2 编程操作

第 1 步：按下  键超过 2 秒，PAUSE 灯亮、同时 TIMER 灯或 COUNTER 灯闪亮，指示预设的间歇控制方式
例如：定时器控制(出厂设定)

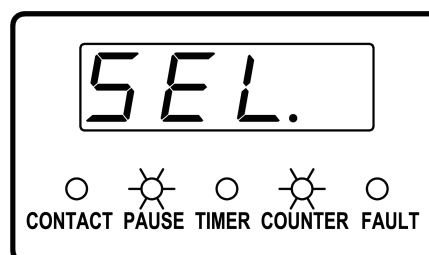

第 2 步：可以用  键改变间歇控制方式，相应的 TIMER 灯或 COUNTER 灯跟随设定的改变闪亮
例如：改为计数器控制



第 3 步：按  键，确定控制方式。LED 显示器开始显示预设的间歇控制参数
例如：480 分钟(出厂设定)

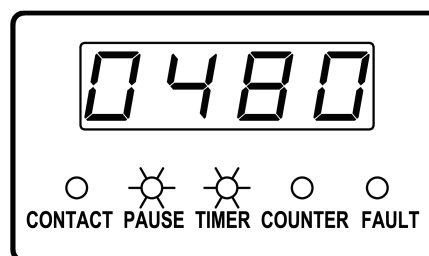

第 4 步：可以用   键修改间歇控制参数数值
例如：修改成 540 分钟(9 小时)

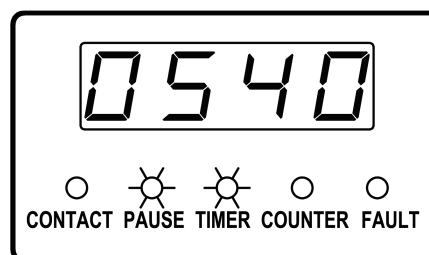

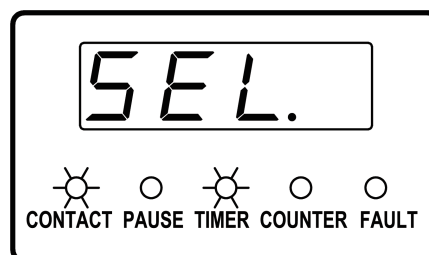

第 5 步：按  键，确认新的间歇控制参数。PAUSE 灯熄灭、CONTACT 灯点亮，开始指示预设的润滑控制方式
例如：定时器控制(出厂设定)

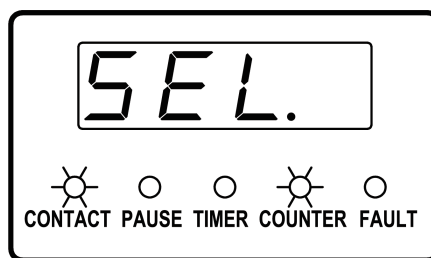

第 6 步：可以用  键改变润滑控制方式，相应的 **TIMER** 灯或 **COUNTER** 灯跟随设定的改变闪亮

例如：改为计数器控制



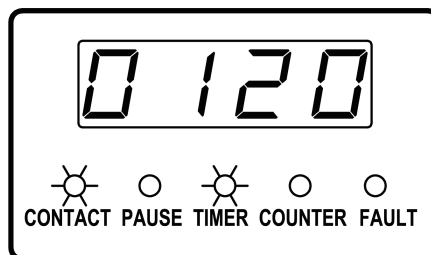

第 7 步：按  键，确定润滑控制方式。LED 显示器开始显示预设的润滑控制参数
例如：120 秒(出厂设定)

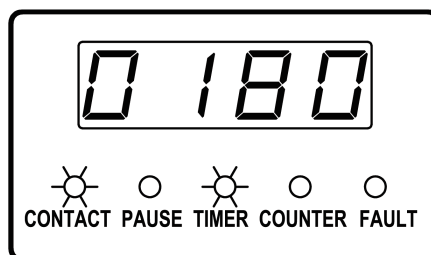

第 8 步：可以用   键修改润滑控制参数数值

例如：修改成 180 秒(3 分钟)



第 9 步：按  键，确认新的润滑控制参数。

LED 显示器显示 **End** 字样，表示编程操作过程结束

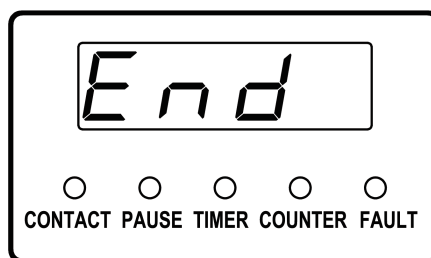

第 10 步：按  键，LED 显示器关闭，退出编程操作状态。

编程确认的控制参数和控制方式被永久保存，直到被下一次编程改变

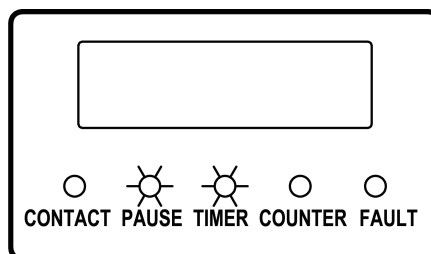

4. 工作模式

4.1 定时工作方式

设定“间歇定时器控制”和“润滑定时器控制”

润滑以时间为控制基础，按照预先设定的间歇时间和润滑时间，循环实现“间歇”-“润滑”的控制

按下  键或者外接 DK 按钮，可以启动一个中间润滑循环或者消除故障显示。外接 DK 按钮可以接到 DK/MK 输入端

4.2 计数工作方式(间歇以外接脉冲计数控制)

设定“间歇计数器控制”和“润滑定时器控制”

外接脉冲传感器信号接到 DK/MK 输入端

间歇：显示和设置的参数为计数脉冲数

润滑：显示和设置的参数为时间

4.3 组合工作方式(泵的运转以外接脉冲计数控制)

间歇：显示和设置的参数为计数脉冲数或者时间

润滑：显示和设置的参数为计数脉冲数

可以组合成“间歇计数器控制”和“润滑计数器控制”，或者“间歇定时器控制”和“润滑计数器控制”

4.4 系统监控

控制器是内置压力开关监控功能的，采用压力开关监测主油管内压力的建立。如果润滑期间压力开关没有检测到主油管内压力建立，故障能够被自动检测和显示出来。

如果润滑系统不需要压力监控，可以将控制器 PS 输入端(压力开关信号) 与 15 输入端(电源正极)短接。在这种方式下，润滑循环只能按照设定的间歇和润滑参数控制，而不去执行故障监控。

4.5 断电保护功能

控制器具备断电保护功能。控制器断电时候，能够自动记忆断电时刻工作状态、剩余参数以及系统内部相关数据。当控制器再次上电时候，能够从断电点继续执行原来的润滑任务。

控制器采用 **EEPROM** 记忆工作状态和参数。记忆的时间是长期的，能可靠存储 10 年以上。

5. 故障监测和处理

当控制器检测到系统故障时候，操作控制面板的 **FAULT** 指示灯会急速闪烁；如果外接了 **SL** 指示灯，**SL** 指示灯也跟随持续闪亮，以提示用户：润滑系统发生了故障。同时，控制器停止工作，等待用户处理故障。用户可以通过显示控制面板察看具体的故障原因。

5.1 故障显示

短暂按一下  键，故障信息就会显示出来，具体信息含义：



泵在运转期间没有接收到来自压力开关的信号。



控制器内部发生了错误。遇到这种情况，请切断控制器电源，1 分钟后再接通控制器电源。如果故障仍然不能排除，请联系制造商。

5.2 清除故障信号

按下  键或者外接 **DK** 按钮，控制器就可以清除故障信号，重新进入正常润滑周期。

请注意：必须确认并排除故障后才能使用  键或外接 **DK** 按钮，否则设备将因缺乏润滑而发生损坏！因为缺乏润滑造成用户设备损坏，由用户自行负责。

5.3 压力开关检测

如果外接了压力开关，那么泵在运转期间没有收到压力开关的信号，将自动停止运行，发出故障报警信号。

6. 技术参数

标称供电电压:	12V~42V
防护等级:	IP40
M 最大输出:	16A
SL 输出:	5W
数据存储:	无限制
工作温度:	-35℃~75℃
储存温度:	-45℃~85℃
推荐保险丝规格:	10A
外形尺寸:	137mm(长)×92mm(宽)×42mm(高)
单件质量:	200g
润滑时间设置范围:	1秒~9999秒
间歇时间设置范围:	1分钟~9999分钟
计数脉冲设置范围:	1~9999

