

Optoway

TRSL-33100W-CXX0G

TRSL-33100W-CXX0G

3.3V / CWDM / 155 Mbps SFF **2X10** LC SINGLE-MODE TRANSCEIVER

FEATURES

- I Duplex LC Single Mode Transceiver
- I SONET OC-3 LR-2 / SDH STM-1 (L-1.2) Compliant
- I Small Form Factor, RJ-45 size, 2X10 pin Package
- I **18-Wavelength** CWDM DFB LD Transmitter from 1270 nm to 1610 nm, with step 20 nm
- I 31 dB Link Budget at Least
- I Analog Monitor Function
 - Transmitter Laser Bias Current
 - Transmitter Laser Optical Power Monitor
 - Receiver Photo Detector Current
- I LVPECL Signal Input / Output
- I LVTTTL Transmitter Disable Input
- I LVTTTL Signal Detection Output
- I Single +3.3 V Power Supply
- I 0 to 70°C Operation
- I Wave Solderable and Aqueous Washable
- I Class 1 Laser International Safety Standard IEC 60825 Compliant

DESCRIPTION

The TRSL-33100W-CXX0G series single mode transceivers is low power, high performance CWDM modules for bi-directional serial optical data communications such as long-reach SONET OC-3 LR / SDH STM-1 and Fast Ethernet. There are eighteen center wavelengths available from 1270 nm to 1610 nm, each step 20 nm. A guaranteed minimum optical link budget of 31 dB is offered. The transmitter section uses a multiple quantum well DFB laser and is a class 1 laser compliant according to International Safety Standard IEC-60825. The receiver section uses an integrated InGaAs detector preamplifier (IDP) mounted in an optical header and a limiting post-amplifier IC. A PECL logic interface simplifies interface to external circuitry.

LASER SAFETY

This single mode transceiver is a Class 1 laser product. It complies with IEC 60825 and FDA 21 CFR 1040.10 and 1040.11. The transceiver must be operated within the specified temperature and voltage limits. The optical ports of the module shall be terminated with an optical connector or with a dust plug.

APPLICATIONS

- I ATM 155 Mbps Links
- I SONET/SDH Equipment Interconnect
- I Fast Ethernet 100 Mb/s Links

ORDER INFORMATION

P/No.	Bit Rate (Mb/s)	SDH/SONET	Power Budget (dB)	Wavelength (nm)	Package	Temp. (°C)	TX Power (dBm)	RX Sens. (dBm)	RoHS Compliant
TRSL-33100W-CXX0G	155		≥31	CWDM*	2X10 LC	0 to 70	2 to -3	-34	Yes

CWDM Wavelength (0 to 70°C)

Central Wavelength	Min. (nm)	Typ. (nm)	Max. (nm)	Central Wavelength	Min. (nm)	Typ. (nm)	Max. (nm)
-C270	1264.5	1270	1277.5	-C450	1444.5	1450	1457.5
-C290	1284.5	1290	1297.5	-C470	1464.5	1470	1477.5
-C310	1304.5	1310	1317.5	-C490	1484.5	1490	1497.5
-C330	1324.5	1330	1337.5	-C510	1504.5	1510	1517.5
-C350	1344.5	1350	1357.5	-C530	1524.5	1530	1537.5
-C370	1364.5	1370	1377.5	-C550	1544.5	1550	1557.5
-C390	1384.5	1390	1397.5	-C570	1564.5	1570	1577.5
-C410	1404.5	1410	1417.5	-C590	1584.5	1590	1597.5
-C430	1424.5	1430	1437.5	-C610	1604.5	1610	1617.5

CWDM*: 18 Wavelengths from 1270 nm to 1610 nm, each step 20 nm.

Absolute Maximum Ratings					
Parameter	Symbol	Min	Max	Units	Notes
Storage Temperature	Tstg	-40	85	°C	
Operating Temperature	Topr	0	70	°C	With air flow 1m/sec
Soldering Temperature	---		260	°C	10 seconds on leads only
Power Supply Voltage	Vcc	0	4.5	V	
Input Voltage	---	GND	Vcc	V	
Output Current	Iout	0	30	mA	

Recommended Operating Conditions					
Parameter	Symbol	Min	Typ	Max	Units / Notes
Power Supply Voltage	Vcc	3.13	3.3	3.47	V
Operating Temperature	Topr	0		70	°C / air flow 1m/sec
Data Rate			125 / 155	200	Mb/s
Power Supply Current	Icc		200	280	mA

Transmitter Specifications (0°C < Topr < 70°C, 3.13V < Vcc < 3.47V)						
Parameter	Symbol	Min	Typ	Max	Units	Notes
Optical						
Optical Transmit Power	Po	-3	---	2	dBm	1
Output Center Wavelength	λ	$\lambda-5.5$	λ	$\lambda+7.5$	nm	2
Output Spectrum Width	$\Delta\lambda$	---	---	1	nm	-20 dB Width
Side Mode Suppression Ratio	SMSR	30			dB	
Extinction Ratio	ER	10	---	---	dB	
Output Eye	Compliant with Bellcore GR-253-CORE and ITU recommendation G.957					
Optical Rise Time	tr			2	ns	10% to 90% Values
Optical Fall Time	tf			2	ns	10% to 90% Values
Relative Intensity Noise	RIN			-120	dB/Hz	
Total Jitter	TJ			1	ns	3
Electrical						
Data Input Current – Low	IIL	-350			μA	
Data Input Current – High	IiH			350	μA	
Differential Input Voltage	V _{IH} - V _{IL}	300			mV	
Data Input Voltage – Low	V _{IL} - V _{CC}	-2.0		-1.58	V	4
Data Input Voltage -- High	V _{IH} - V _{CC}	-1.1		-0.74	V	4
Disable Input Voltage -- Low	V _{TDIS,L}	0		0.5	V	TX Output Enabled
Disable Input Voltage -- High	V _{TDIS,H}	Vcc – 1.3		Vcc	V	TX Output Disabled
Shut Off Time for TxDis	t _{DIS}			1	ms	

- Notes: 1. Output power is power coupled into a 9/125 μm single mode fiber.
 2. ITU-T G.694.2 CWDM wavelength from 1270 nm to 1610 nm, each step 20 nm.
 3. Measured with a 2²³-1 PRBS with 72 ones and 72 zeros.
 4. These inputs are compatible with 10K, 10KH and 100K ECL and PECL inputs.

Receiver Specifications (0°C < Topr < 70°C, 3.13V < Vcc < 3.47V)						
Parameter	Symbol	Min	Typ	Max	Units	Notes
Optical						
Sensitivity	---	---	---	-34	dBm	1
Maximum Input Power	Pin	-3		---	dBm	
Signal Detect -- Asserted	Pa	---	---	-34	dBm	Transition: low to high
Signal Detect -- Deasserted	Pd	-47	---	---	dBm	Transition: high to low
Signal detect -- Hysteresis		1.0	---		dB	
Wavelength of Operation		1100	---	1620	nm	
Electrical						
Data Output Voltage – Low	V _{OL} - V _{CC}	-2.0		-1.58	V	2
Data Output Voltage – High	V _{OH} - V _{CC}	-1.1		-0.74	V	2
Signal Detect Output Voltage -- Low	V _{OL}			0.5	V	
Signal Detect Output Voltage -- High	V _{OH}	2.0			V	

Notes: 1. Minimum sensitivity and saturation levels at BER=1E-10 for a 2²³-1 PRBS with 72 ones and 72 zeros.
 2. These outputs are compatible with 10K, 10KH and 100K ECL and PECL outputs.

ANALOG DIAGNOSTICS FUNCTIONS

Parameter	Symbol	Min	Typ	Max	Units	Notes
Transmitter						
Laser Bias Current Monitor	Bmon+, Bmon-	0		Vcc	V	1
Monitor Photodiode Current Monitor	Pmon+, Pmon-	0		Vcc	V	2
Receiver						
Received Photocurrent	Rpd	0		1	mA	3
Photodiode Responsivity	R	0.5	0.9	1.0	A/W	
Applied Voltage at VpdR pin	Vpd	2.4		Vcc	V	3

Notes: 1. PIN 17 and 18 provide an analog voltage output proportional to the laser bias current, based on the following formula: $I_{bias} = V (Bmon+ - Bmon-) / 10 \Omega$. See below the equivalent circuit.
 2. PIN 19 and 20 provide an analog voltage output proportional to the monitor photodiode current, based on the following formula: $I_{mon} = V (Pmon+ - Pmon-) / 200 \Omega$. See below the equivalent circuit.
 3. PIN 1 is used to monitor the received photocurrent. It must be connected to a positive voltage within the specified above. The received power is given by the photocurrent multiplied by the photodiode responsivity.

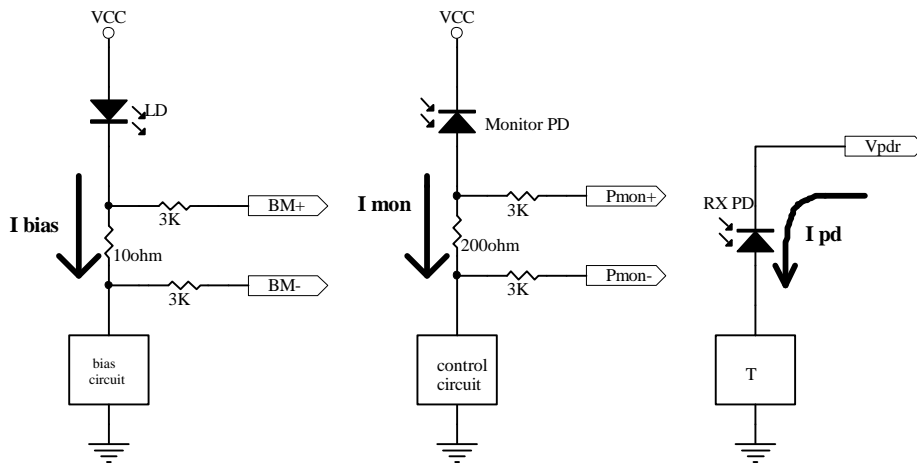

Analog Monitoring Function Connections

PACKAGE DIAGRAM

Units in mm

1) Standard Case

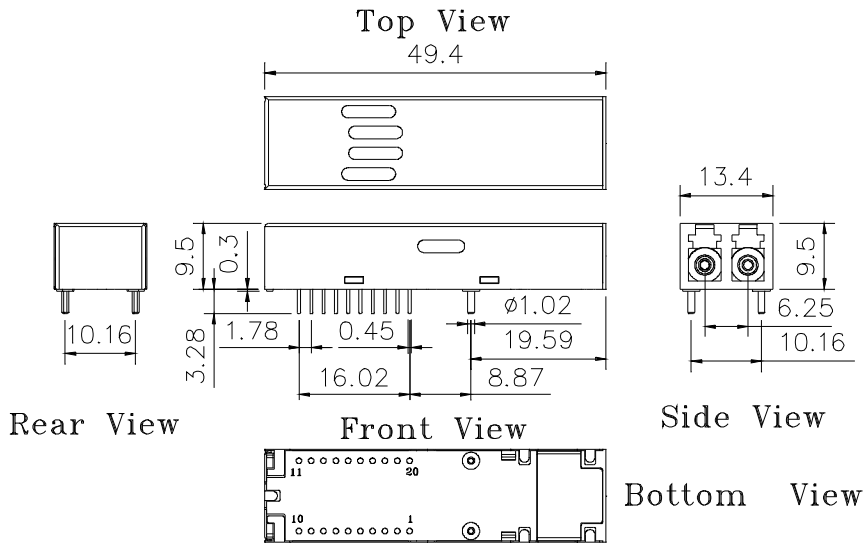

TRSL-33100W-CXX0G

2) Extended Case

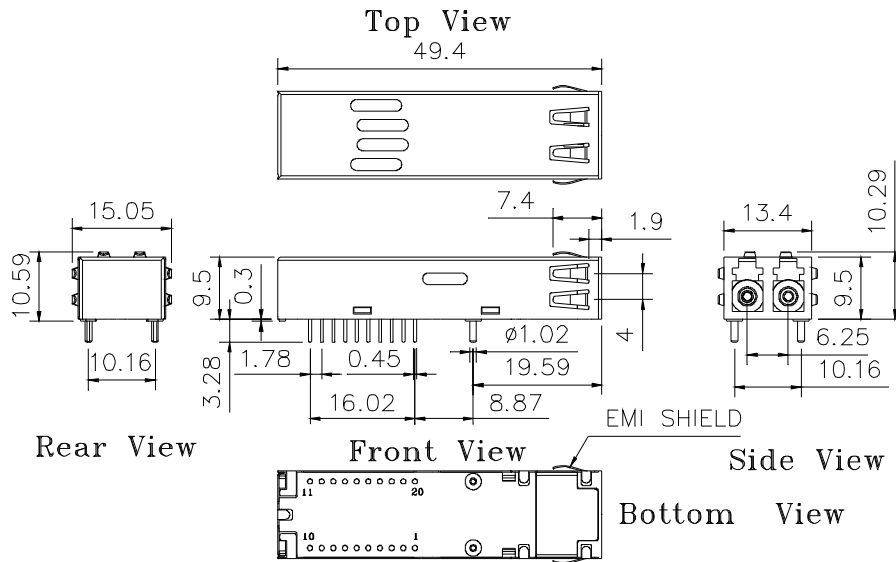

TRSL-33100WE-CXX0G

Note: Specifications subject to change without notice.