

1.25mm Pitch Super Low profile Crimping Connector

DF14 Series

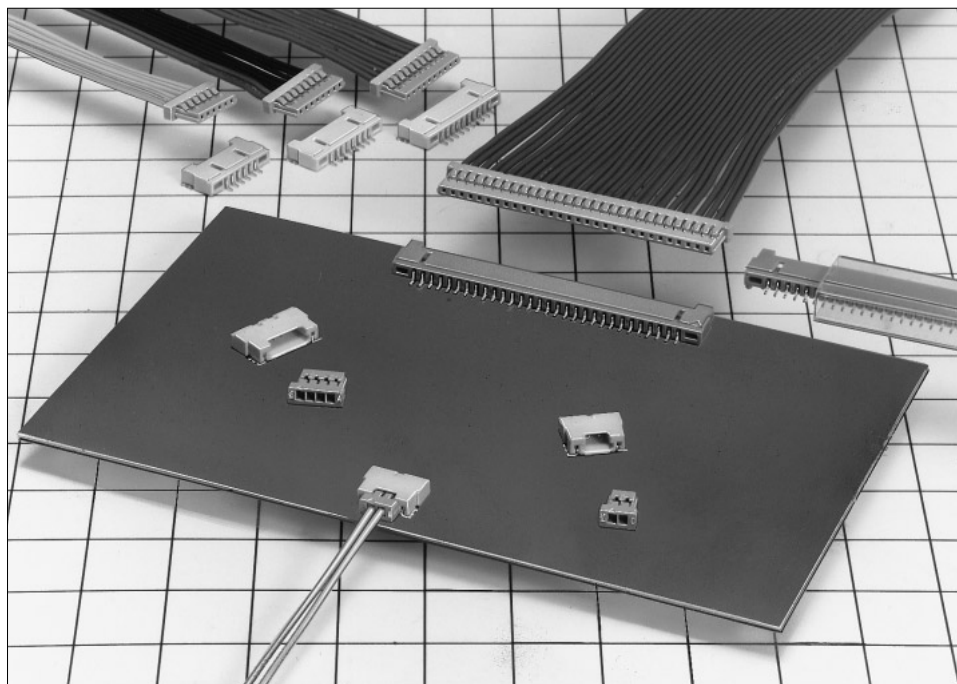

■Features

1. Super Low Profile

This is a connector special for right angle which has pursued a low profile on the board.

Board mounting height: **2.5mm**

A signal can be fetched from the area where there is no board to board space.

2. Correspond to Automatic Mounting

The header has the vacuum mount face which enables the vacuum absorption and the automatic mounting by the embossed tape packaging. In addition, the tube packaging can be selected.

3. Four Wall Type Without Friction to Board by Socket

The header has the box structure to prevent from being twisted and has the perfect mis-insertion prevention method. Moreover the header has the wall on the board side and doesn't have any trouble resulted from the friction to board by socket.

In addition, the metal fitting is attached to prevent the solder peel.

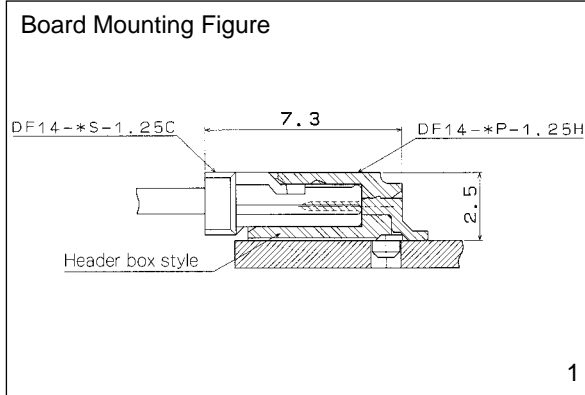

■Applications

LCD, Note PC, Mobile Terminal Small business equipment, Video camera

■Product Specifications

Rating	Current rating 1A	Operating Temperature Range -25 to +85°C (Note 1)	Storage Temperature Range -10 to +60°C (Note 2)
	Voltage rating 150V AC		
Item	Specification	Condition	
1. Insulation Resistance	500M ohms Min	100V DC	
2. Withstanding voltage	No flashover or insulation breakdown.	500V AC/1 minute	
3. Contact Resistance	30m ohms Max	100mA	
4. Insertion/Extraction Force	MIN0.15N (15gf), MAX3N (300gf)	Measure at the square steel pin of 0.3±0.002mm	
5. Vibration	No electrical discontinuity of 1μs or more	Frequency: 10 to 55 Hz, single amplitude of 0.75 mm, 2 hours in each of the 3 directions.	
6. Humidity (Steady state)	Contact resistance: 30m ohms Max Insulation resistance: 500M ohms Min	96 hours at temperature of 40°C and humidity of 90% to 95%	
7. Temperature Cycle	Contact resistance: 30m ohms Max Insulation resistance: 500M ohms Min	(-25°C: 30 minutes → 5 to 35°C: 10 minutes → 85°C: 30 minutes → 5 to 35°C: 10 minutes) 5 cycles	
8. Durability (Mating/un-mating)	Contact resistance: 30m ohms Max	Tin plating: 30 cycles Gold plating: 50 cycles	
9. Resistance to Soldering heat	No deformation of components affecting performance.	Reflow: At the recommended temperature profile	
		Manual soldering: 300°C for 3 seconds	

Note 1: Includes temperature rise caused by current flow.

Note 2: The term "storage" refers to products stored for long period of time prior to mounting and use. Operating Temperature Range and Humidity range covers non conducting condition of installed connectors in storage, shipment or during transportation.

■Material

Product	Part	Material	Finish	Remarks
Crimping Socket	Insulator	Polyamide	Beige	UL-94V-0
Crimping Contact for Socket	Contact	Phosphor Copper	Tin-lead plated or gold plated	————
Pin Header	Insulator	Polyamide	Beige	UL-94V-0
	Contact	Brass	Tin-lead plated or gold plated	————
	Fitting	Phosphor copper	Tin-lead plated	————

Note . Hirose's tin plating product takes measures against whisker.

■Ordering Information

●Connector

DF14 - * S - 1.25 C

① ② ③ ④ ⑤

① Series Name: DF14	④ Contact Pitch: 1.25mm
② Number of Contacts: 2 to 10, 15, 20, 25, 30	⑤ Contact Type C: Crimping socket H: Right angle SMT
③ Connector Type S: Single row socket P: Single row pin header	

●Contact

DF14 - 2628 SCF A

① ② ③

① Applicable cable size 2628: AWG26 to 28 3032: AWG30 to 32	② Packaging Type SCF: Socket contact/reel
	③ Plating Type Blank: Tin plated A: Gold plated

■Crimping Socket

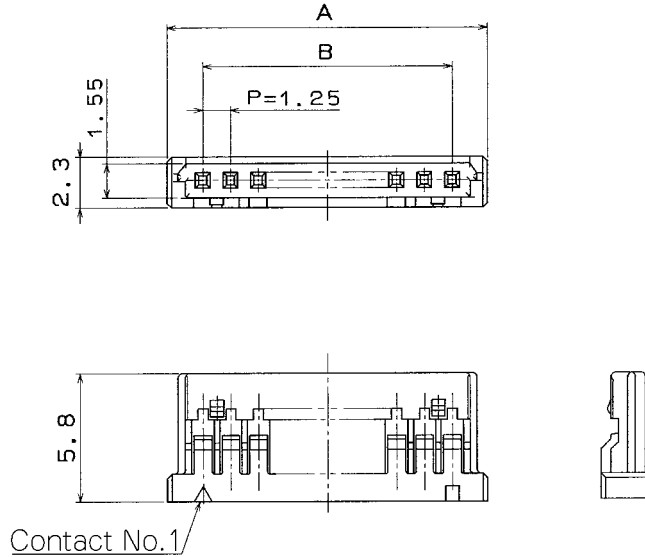
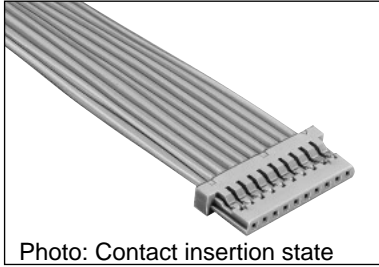

Unit: mm

Part Number	CL No.	Number of Contacts	A	B
DF14- 2S-1.25C(**)	538-0005-8-***	2	4.45	1.25
DF14- 3S-1.25C(**)	538-0006-0-***	3	5.70	2.50
DF14- 4S-1.25C(**)	538-0007-3-***	4	6.95	3.75
DF14- 5S-1.25C(**)	538-0008-6-***	5	8.20	5.00
DF14- 6S-1.25C(**)	538-0009-9-***	6	9.45	6.25
DF14- 7S-1.25C(**)	538-0010-8-***	7	10.70	7.50
DF14- 8S-1.25C(**)	538-0011-0-***	8	11.95	8.75
DF14- 9S-1.25C(**)	538-0013-6-***	9	13.20	10.00
DF14-10S-1.25C(**)	538-0014-9-***	10	14.45	11.25
DF14-15S-1.25C(**)	538-0054-3-***	15	20.70	17.50
DF14-20S-1.25C(**)	538-0059-7-***	20	26.95	23.75
DF14-25S-1.25C(**)	538-0064-7-***	25	33.20	30.00
DF14-30S-1.25C(**)	538-0012-3-***	30	39.45	36.25

[Specific No.]-***(**)
Blank : 1 bag 100 pcs.

Note 1.The quantity at the specific No. "Blank" is delivered per bag. If needed, please order the products per bag.

■Socket Crimping Contact

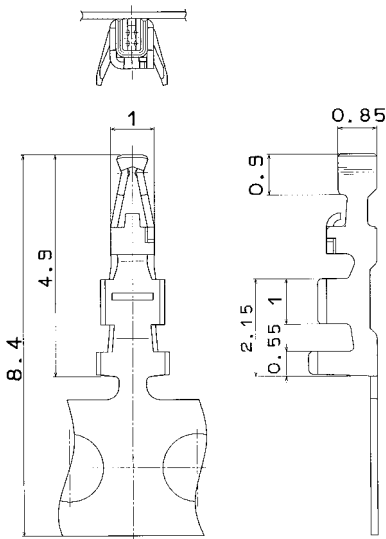

Part Number	CL No.	Packaging Type	Quantity	Finish
DF14-2628SCF	538-0001-7-***	Reel	10,000	Tin plated
DF14-3032SCF	538-0003-2-***	Reel		

●Applicable Cable (Tin plating Annealed copper wire)

Conductor Size (Wire construction)	Jacket Diameter
AWG26(7 cores/0.16mm)	φ0.54 to φ1mm
AWG28(7 cores/0.127mm)	
AWG30(7 cores/0.1mm)	
AWG32(7 cores/0.08mm)	

●Recommended Cable

UL1571

●Strip Length

1.2 to 1.9mm

Note:If other cables are used instead of the applicable cable, contact Hirose sales department.

◆Applicable Crimping Tool

Type	Part Number	CL No.	Applicable Contact
Applicator	AP105-DF14-2628S	901-4548-1	DF14-2628SCF/SCFA
	AP105-DF14-3032S	901-4544-0	DF14-3032SCF/SCFA
Press Main Unit	CM-105	901-0005-4	_____
Manual Crimping Tool	DF14-2628/CR-HT	550-0261-1	DF14-2628SCF/SCFA
	DF14-3032/CR-HT	550-0262-4	DF14-3032SCF/SCFA

Note 1.If a trouble has occurred due to tools, which are not designated by Hirose, Hirose won't guarantee any product.

Note 2.Use the reel contact sequentially cut for manual crimping tool.

■Right Angle Pin Header (SMT)

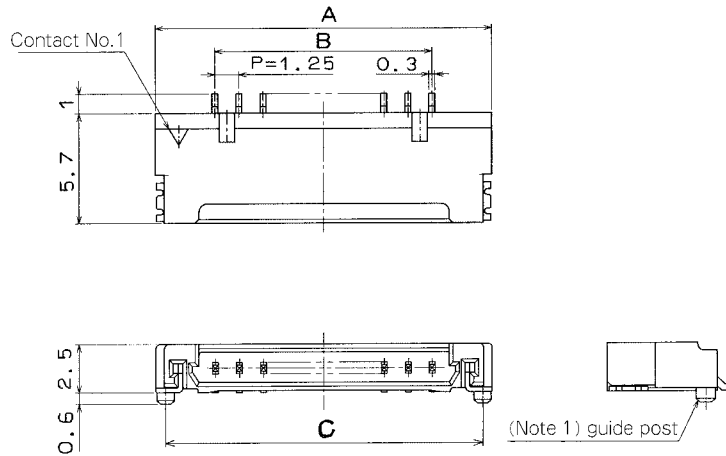
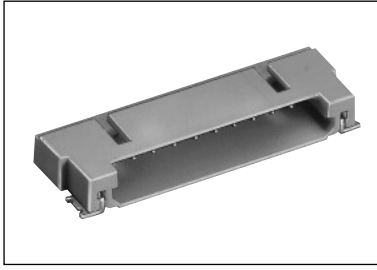

Note 1: "Without boss" indicates the style with no boss.

◆PCB mounting pattern

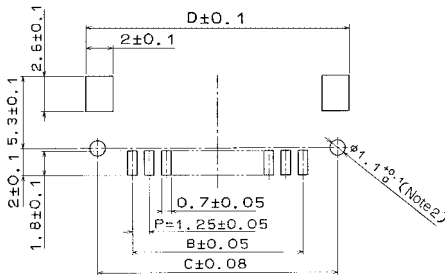

Note 2: "Without boss" indicates that no hole is needed.

◆Tube Packaging Dimensions

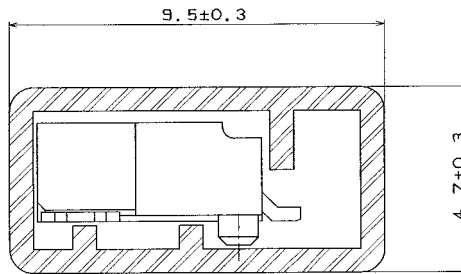

[Specific No.]—**, (**)
 (20): Tin plated tube packaging
 (21): Tin plated embossed tape packaging
 (50): Gold plated tube packaging
 (59): Gold plated embossed tape packaging

Unit: mm

With boss		Without boss		Number of Contacts	A	B	C	D	Tube Packaging Quantity
Part Number	CL No.	Part Number	CL No.						
DF14- 2P-1.25H(**)	538-0021-4-**	DF14A- 2P-1.25H(**)	538-0033-3-**	2	7.45	1.25	6.45	8.05	66
DF14- 3P-1.25H(**)	538-0022-7-**	DF14A- 3P-1.25H(**)	538-0034-6-**	3	8.70	2.50	7.70	9.30	56
DF14- 4P-1.25H(**)	538-0023-0-**	DF14A- 4P-1.25H(**)	538-0035-9-**	4	9.95	3.75	8.95	10.55	49
DF14- 5P-1.25H(**)	538-0024-2-**	DF14A- 5P-1.25H(**)	538-0036-1-**	5	11.20	5.00	10.20	11.80	44
DF14- 6P-1.25H(**)	538-0025-5-**	DF14A- 6P-1.25H(**)	538-0037-4-**	6	12.45	6.25	11.45	13.05	39
DF14- 7P-1.25H(**)	538-0026-8-**	DF14A- 7P-1.25H(**)	538-0038-7-**	7	13.70	7.50	12.70	14.30	36
DF14- 8P-1.25H(**)	538-0027-0-**	DF14A- 8P-1.25H(**)	538-0039-0-**	8	14.95	8.75	13.95	15.55	32
DF14- 9P-1.25H(**)	538-0028-3-**	DF14A- 9P-1.25H(**)	538-0040-9-**	9	16.20	10.00	15.20	16.80	30
DF14-10P-1.25H(**)	538-0029-6-**	DF14A-10P-1.25H(**)	538-0041-1-**	10	17.45	11.25	16.45	18.05	28
DF14-15P-1.25H(**)	538-0084-4-**	DF14A-15P-1.25H(**)	538-0114-3-**	15	23.70	17.50	22.70	24.30	20
DF14-20P-1.25H(**)	538-0089-8-**	DF14A-20P-1.25H(**)	538-0119-7-**	20	29.95	23.75	28.95	30.55	16
DF14-25P-1.25H(**)	538-0094-8-**	DF14A-25P-1.25H(**)	538-0124-7-**	25	36.20	30.00	35.20	36.80	13
DF14-30P-1.25H(**)	538-0020-1-**	DF14A-30P-1.25H(**)	538-0045-2-**	30	42.45	36.25	41.45	43.05	11

Note 1. Please order the tube packaging product, multiplying the packaging quantity (pcs.).

Note 2. Please order the embossed tape packaging product according to reel number. (1000 pcs./reel)

◆ Embossed Carrier Tape Dimensions

■ 2 to 10 Contacts

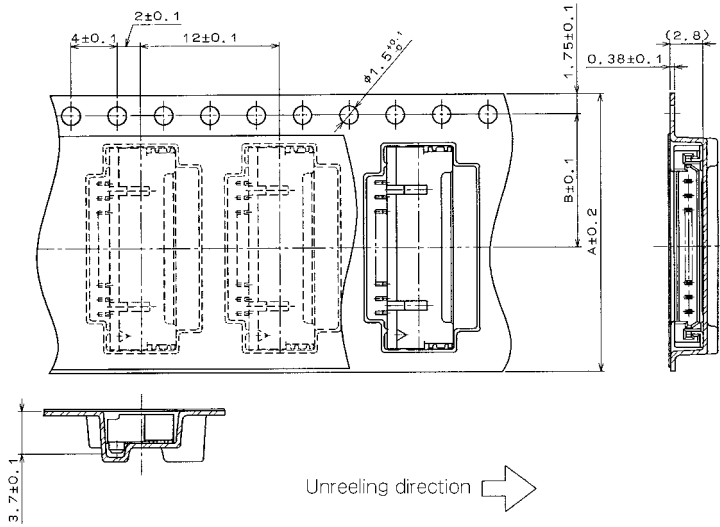

■ 15, 20, 25, 30 Contacts

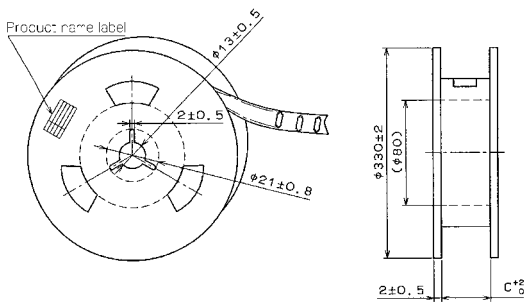
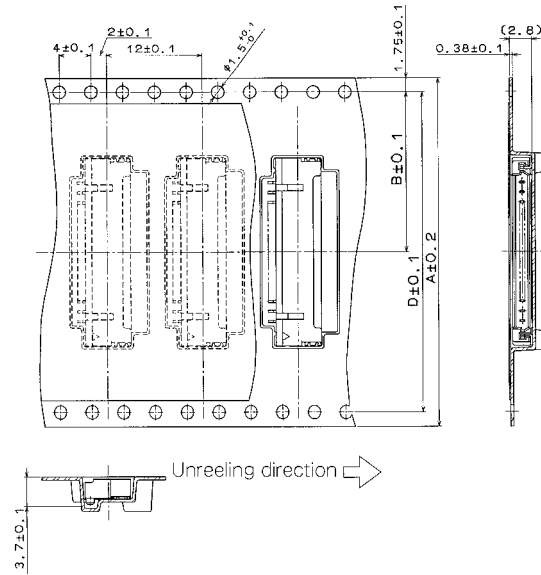

Unit: mm

Inserted Connector	Number of Contacts	A	B	C	D
DF14/14A- 2P-1.25H	2	16	7.5	16.4	—
DF14/14A- 3P-1.25H	3	16	7.5	16.4	—
DF14/14A- 4P-1.25H	4	24	11.5	24.4	—
DF14/14A- 5P-1.25H	5	24	11.5	24.4	—
DF14/14A- 6P-1.25H	6	24	11.5	24.4	—
DF14/14A- 7P-1.25H	7	24	11.5	24.4	—
DF14/14A- 8P-1.25H	8	24	11.5	24.4	—
DF14/14A- 9P-1.25H	9	24	11.5	24.4	—
DF14/14A-10P-1.25H	10	24	11.5	24.4	—
DF14/14A-15P-1.25H	15	44	20.2	44.4	40.4
DF14/14A-20P-1.25H	20	44	20.2	44.4	40.4
DF14/14A-25P-1.25H	25	56	26.2	56.4	52.4
DF14/14A-30P-1.25H	30	56	26.2	56.4	52.4

◆Precautions

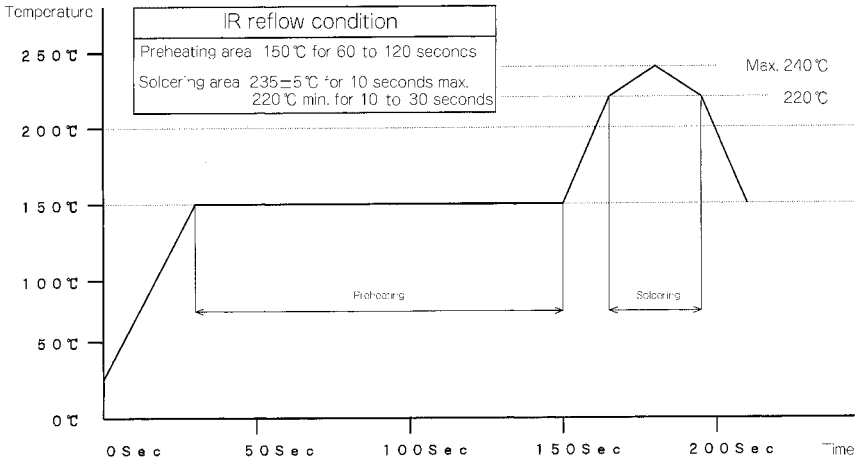
<p>1. Recommended Temperature Profile (SMT)</p>	 <p>Note 1. The soldering process is allowed up to twice under the same condition. However, the interval between the first and second processes must be maintained at the room temperature.</p> <p>Note 1. The temperature indicates the board surface temperature on the connector lead area.</p>
<p>2. Recommended Manual Soldering Condition (SMT)</p>	<p>Manual soldering: 290°C for 2 seconds</p>
<p>3. Recommended Screen Thickness (SMT)</p>	<p>0.15 to 0.2mm</p>
<p>4. Board Sled (SMT)</p>	<p>Max 0.03mm at the connector center area, based on both connector edges</p>
<p>5. Cleaning Condition</p>	<p>Refer to Nylon Connector Use Hand book.</p>
<p>6. Connection Condition</p>	<p>Refer to Nylon Connector Use Hand book.</p> <p>■Be careful to carry out the crimping operation according to the "Crimping Condition Sheet" and "Crimping Quality Reference", because the crimping contact style is too small.</p>
<p>7. Cautions</p>	<p>■Be careful for an excessive scoop insertion/extraction, which will cause damage to the product.</p>