

**FEATURES**

- 3.3V and 5V power supplies required
- Also, supports LVPECL-to-PECL translation
- 500ps propagation delays
- Fully differential design
- Differential line receiver capability
- Available in 28-pin PLCC package

**BLOCK DIAGRAM**

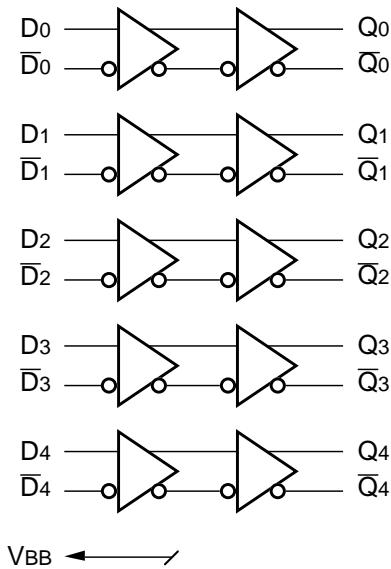

**FUNCTION TABLE**

Function	Vcc	Vcco	Vcc_VBB
PECL-to-LVPECL	5.0V	3.3V	5.0V
LVPECL-to-PECL	5.0V	5.0V	3.3V
PECL-to-PECL	5.0V	5.0V	5.0V
LVPECL-to-LVPECL	5.0V	3.3V	3.3V

**DESCRIPTION**

The SY100E417 is a quint LVPECL-to-PECL translator. It can also be used as a quint PECL-to-LVPECL translator. The device receives standard PECL signals and translates them to differential LVPECL output signals (or vice versa).

The SY100E417 can also be used as a differential line receiver for PECL-to-PECL or LVPECL-to-LVPECL signals. However, please note that for the latter we will need two different power supplies. Please refer to Function Table for more details.

A  $V_{BB}$  output is provided for interfacing single ended input signals. If a single ended input is to be used, the  $V_{BB}$  output should be connected to the  $\bar{D}_n$  input and the active signal will drive the  $D_n$  input. When used, the  $V_{BB}$  should be bypassed to  $V_{CC}$  via a  $0.01\mu F$  capacitor. The  $V_{BB}$  is designed to act as a switching reference for the SY100E417 under single ended input conditions. As a result, the pin can only source/sink 0.5mA of current.

To accomplish the PECL-to-LVPECL level translation, the SY100E417 requires three power rails. The  $V_{CC}$  and  $V_{CC\_VBB}$  supply is to be connected to the standard PECL supply, the 3.3V supply is to be connected to the  $V_{CCO}$  supply, and GND is connected to the system ground plane. Both the  $V_{CC}$  and  $V_{CCO}$  should be bypassed to ground with a  $0.01\mu F$  capacitor.

To accomplish the LVPECL-to-PECL level translation, the SY100E417 requires three power rails as well. The 5.0V supply is connected to the  $V_{CC}$  and  $V_{CCO}$  pins, 3.3V supply is connected to the  $V_{CC\_VBB}$  pin and GND is connected to the system ground plane.  $V_{CC\_VBB}$  is used to provide a proper  $V_{BB}$  output level if a single ended input is used.  $V_{CC\_VBB} = 3.3V$  is only required for single-ended LVPECL input. For differential LVPECL input,  $V_{CC\_VBB}$  can be either 3.3V or 5.0V.

Under open input conditions, the  $D_n$  input will be biased at a  $V_{CC}/2$  voltage level and the  $\bar{D}_n$  input will be pulled to GND. This condition will force the "Qn" output low, ensuring stability.

**PIN CONFIGURATION**

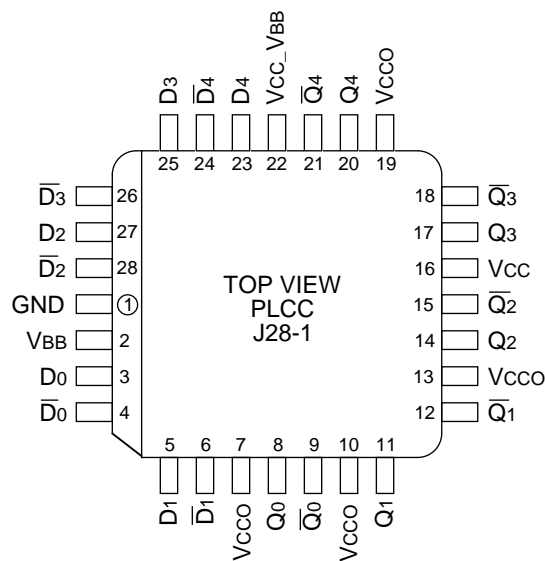

**PIN NAMES**

Pin	Function
D <sub>n</sub>	PECL / LVPECL Inputs
Q <sub>n</sub>	PECL / LVPECL Outputs
V <sub>BB</sub>	Reference Voltage Output
V <sub>CCO</sub>	V <sub>cc</sub> for Outputs
V <sub>CC_VBB</sub>	V <sub>cc</sub> for V <sub>BB</sub> Output
GND	Common Ground Rail
V <sub>CC</sub>	V <sub>cc</sub> for Internal Circuitry

**PECL INPUT DC ELECTRICAL CHARACTERISTICS**

V<sub>CC\_VBB</sub> = V<sub>CC</sub> = +4.5V to +5.5V

Symbol	Parameter	T <sub>A</sub> = -40°C			T <sub>A</sub> = 0°C			T <sub>A</sub> = +25°C			T <sub>A</sub> = +85°C			Unit
		Min.	Typ.	Max.	Min.	Typ.	Max.	Min.	Typ.	Max.	Min.	Typ.	Max.	
V <sub>CC</sub>	Power Supply Voltage	4.5	—	5.5	4.5	—	5.5	4.5	—	5.5	4.5	—	5.5	V
V <sub>IH</sub>	Input HIGH Voltage <sup>(1)</sup>	3.835	—	4.120	3.835	—	4.120	3.835	—	4.120	3.835	—	4.120	V
V <sub>IL</sub>	Input LOW Voltage <sup>(1)</sup>	3.190	—	3.515	3.190	—	3.525	3.190	—	3.525	3.190	—	3.525	V
V <sub>PP</sub>	Minimum Peak-to-Peak Input	150	—	—	150	—	—	150	—	—	150	—	—	mV
I <sub>IH</sub>	Input HIGH Current	—	—	150	—	—	150	—	—	150	—	—	150	μA
I <sub>IL</sub>	Input LOW Current	$\frac{D_n}{D_n}$ 0.5 -600	— —	— —	0.5 -600	— —	— —	0.5 -600	— —	— —	0.5 -600	— —	— —	μA
V <sub>BB</sub>	Output Reference <sup>(1)</sup>	3.620	—	3.740	3.620	—	3.740	3.620	—	3.740	3.620	—	3.740	V
I <sub>CC</sub>	Power Supply Current	—	—	20	—	—	20	—	14	20	—	—	20	mA

**NOTE:**

1. These levels are for V<sub>CC\_VBB</sub> = 5.0V. Level specifications will vary 1:1 with V<sub>CC\_VBB</sub>.

## LVPECL OUTPUT DC ELECTRICAL CHARACTERISTICS

VCC = +4.5V to +5.5V; VCCO = +3.0V to 3.8V

Symbol	Parameter	TA = -40°C			TA = 0°C			TA = +25°C			TA = +85°C			Unit
		Min.	Typ.	Max.	Min.	Typ.	Max.	Min.	Typ.	Max.	Min.	Typ.	Max.	
VCCO	Power Supply Voltage	3.0	—	3.8	3.0	—	3.8	3.0	3.3	3.8	3.0	—	3.8	V
VOH	Output HIGH Voltage <sup>(1)</sup>	2.215	—	2.420	2.275	—	2.420	2.275	2.350	2.420	2.275	—	2.420	V
VOL	Output LOW Voltage <sup>(1)</sup>	1.470	—	1.745	1.490	—	1.680	1.490	1.600	1.680	1.490	—	1.680	V
ICCO	Power Supply Current	—	—	35	—	—	35	—	23	35	—	—	37	mA

### NOTE:

1. These levels are for VCCO = 3.3V. Level specifications will vary 1:1 with VCCO.

## LVPECL INPUT DC ELECTRICAL CHARACTERISTICS

VCC\_VBB = +3.0V to +3.8V<sup>(1)</sup>; VCC = +4.5V to +5.5V

Symbol	Parameter	TA = -40°C			TA = 0°C			TA = +25°C			TA = +85°C			Unit
		Min.	Typ.	Max.	Min.	Typ.	Max.	Min.	Typ.	Max.	Min.	Typ.	Max.	
VCC	Power Supply Voltage	4.5	—	5.5	4.5	—	5.5	4.5	—	5.5	4.5	—	5.5	V
VIH	Input HIGH Voltage <sup>(2)</sup>	2.135	—	2.420	2.135	—	2.420	2.135	—	2.420	2.135	—	2.420	V
VIL	Input LOW Voltage <sup>(2)</sup>	1.490	—	1.825	1.490	—	1.825	1.490	—	1.825	1.490	—	1.825	V
VPP	Minimum Peak-to-Peak Input	150	—	—	150	—	—	150	—	—	150	—	—	mV
I <sub>IH</sub>	Input HIGH Current	—	—	150	—	—	150	—	—	150	—	—	150	μA
I <sub>IL</sub>	Input LOW Current	0.5	—	—	0.5	—	—	0.5	—	—	0.5	—	—	μA
		-600	—	—	-600	—	—	-600	—	—	-600	—	—	
VBB	Output Reference <sup>(2)</sup>	1.92	—	2.04	1.92	—	2.04	1.92	—	2.04	1.92	—	2.04	V
ICC	Power Supply Current	—	—	20	—	—	20	—	14	20	—	—	20	mA

### NOTES:

- VCC\_VBB = 3.3V is only required for single-ended LVPECL input. For differential LVPECL input, VCC\_VBB can be either 3.3V or 5V.
- These levels are for VCC\_VBB = 3.3V. Level specifications will vary 1:1 with VCC\_VBB.

**PECL OUTPUT DC ELECTRICAL CHARACTERISTICS**

VCC = VCCO = +4.5V to +5.5V

Symbol	Parameter	TA = -40°C			TA = 0°C			TA = +25°C			TA = +85°C			Unit
		Min.	Typ.	Max.	Min.	Typ.	Max.	Min.	Typ.	Max.	Min.	Typ.	Max.	
VCCO	Power Supply Voltage	4.5	—	5.5	4.5	—	5.5	4.5	—	5.5	4.5	—	5.5	V
VOH	Output HIGH Voltage <sup>(1)</sup>	3.915	—	4.120	3.975	—	4.120	3.975	—	4.120	3.975	—	4.120	V
VoL	Output LOW Voltage <sup>(1)</sup>	3.170	—	3.445	3.190	—	3.380	3.190	—	3.380	3.190	—	3.380	V
Icco	Power Supply Current	—	—	35	—	—	35	—	23	35	—	—	37	mA

**NOTES:**

1. These levels are for VCCO = 5.0V. Level specifications will vary 1:1 with VCCO.

**AC ELECTRICAL CHARACTERISTICS<sup>(1)</sup>**

Symbol	Parameter	TA = -40°C			TA = 0°C			TA = +25°C			TA = +85°C			Unit
		Min.	Typ.	Max.	Min.	Typ.	Max.	Min.	Typ.	Max.	Min.	Typ.	Max.	
tPLH	Propagation Delay Diff.	410	510	610	410	510	610	410	510	610	410	510	610	ps
tPHL	D to Q S.E.	380	530	680	380	530	680	380	530	680	380	530	680	
tskew	Within-Device Skew	—	—	—	—	—	—	—	—	—	—	—	—	ps
	Output-to-Output <sup>(2)</sup>	—	20	100	—	20	100	—	20	100	—	20	100	
	Part-to-Part (Diff.) <sup>(2)</sup>	—	20	200	—	20	200	—	20	200	—	20	200	
	Duty Cycle (Diff.) <sup>(3)</sup>	—	25	—	—	25	—	—	25	—	—	25	—	
VPP	Minimum Input Swing <sup>(4)</sup>	150	—	—	150	—	—	150	—	—	150	—	—	mV
VCMR	Common Mode Range <sup>(5)</sup>	—	—	—	—	—	—	—	—	—	—	—	—	V
	VPP < 500mV	1.3	—	VCC-0.2	1.2	—	VCC-0.2	1.2	—	VCC-0.2	1.2	—	VCC-0.2	
	VPP ≥ 500mV	1.5	—	VCC-0.2	1.4	—	VCC-0.2	1.4	—	VCC-0.2	1.4	—	VCC-0.2	
tr	Output Rise/Fall Times Q (20% to 80%)	320	—	580	320	—	580	320	—	580	320	—	580	ps
tf														

**NOTES:**

1. Power supply requirements applies as indicated in the DC electrical characteristics tables.
2. Skew is measured between outputs under identical transitions.
3. Duty cycle skew is the difference between a TPLH and TPHL propagation delay through a device Common Mode Range.
4. Minimum input swing for which AC parameters are guaranteed. The device has a DC gain of ~40.
5. The CMR range is referenced to the most positive side of the differential input signal. Normal operation is obtained if the HIGH level falls within the specified range and the peak-to-peak voltage lies between VPP min. and 1V.

**PRODUCT ORDERING CODE**

Ordering Code	Package Type	Operating Range
SY100E417JC	J28-1	Commercial
SY100E417JCTR	J28-1	Commercial

Ordering Code	Package Type	Operating Range
SY100E417JI	J28-1	Industrial
SY100E417JITR	J28-1	Industrial

**28 LEAD PLCC (J28-1)**

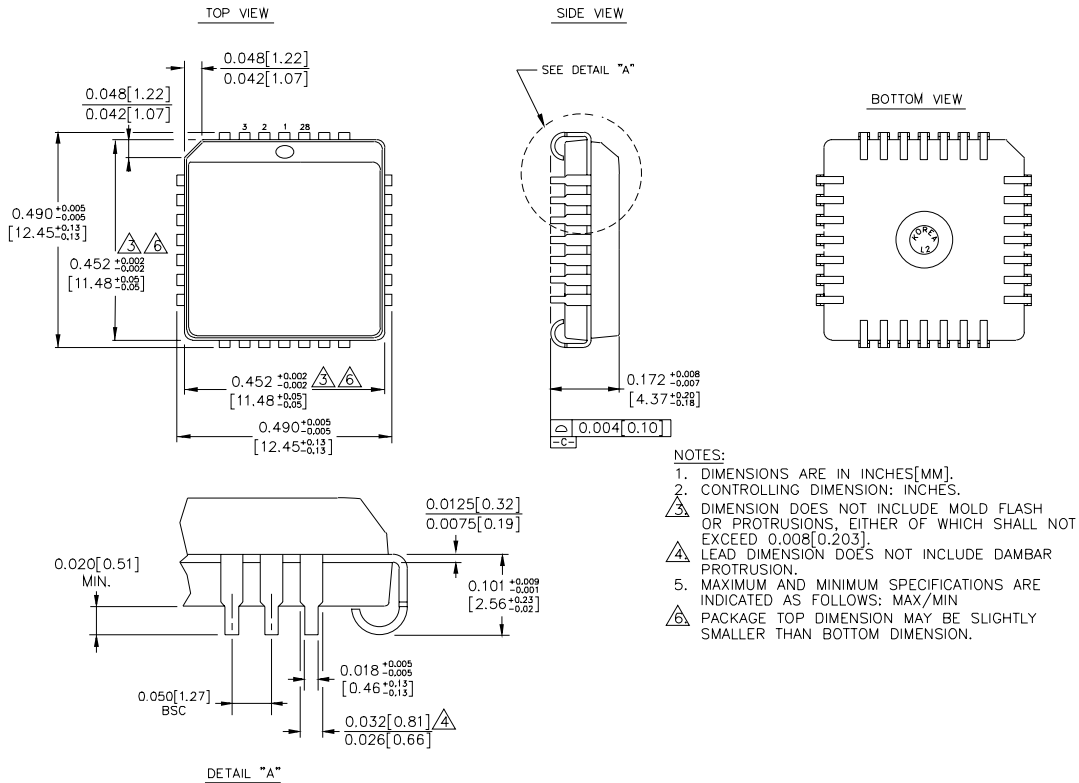

Rev. 03

**MICREL-SYNERGY 3250 SCOTT BOULEVARD SANTA CLARA CA 95054 USA**

TEL + 1 (408) 980-9191 FAX + 1 (408) 914-7878 WEB <http://www.micrel.com>

This information is believed to be accurate and reliable, however no responsibility is assumed by Micrel for its use nor for any infringement of patents or other rights of third parties resulting from its use. No license is granted by implication or otherwise under any patent or patent right of Micrel Inc.

© 2000 Micrel Incorporated