



**HIGH SPEED  
2K x 8 DUAL PORT  
STATIC RAM**

**IDT7132SA/LA  
IDT7142SA/LA**

**Features**

- ◆ **High-speed access**
  - Commercial: 20/25/35/55/100ns (max.)
  - Industrial: 25ns (max.)
  - Military: 25/35/55/100ns (max.)
- ◆ **Low-power operation**
  - IDT7132/42SA  
Active: 325mW (typ.)  
Standby: 5mW (typ.)
  - IDT7132/42LA  
Active: 325mW (typ.)  
Standby: 1mW (typ.)
- ◆ MASTER IDT7132 easily expands data bus width to 16-or-more bits using SLAVE IDT7142
- ◆ On-chip port arbitration logic (IDT7132 only)
- ◆  $\overline{\text{BUSY}}$  output flag on IDT7132;  $\overline{\text{BUSY}}$  input on IDT7142
- ◆ Battery backup operation —2V data retention (LA only)
- ◆ TTL-compatible, single 5V  $\pm 10\%$  power supply
- ◆ Available in 48-pin DIP, LCC and Flatpack, and 52-pin PLCC packages
- ◆ Military product compliant to MIL-PRF-38535 QML
- ◆ Industrial temperature range ( $-40^{\circ}\text{C}$  to  $+85^{\circ}\text{C}$ ) is available for selected speeds

**Functional Block Diagram**

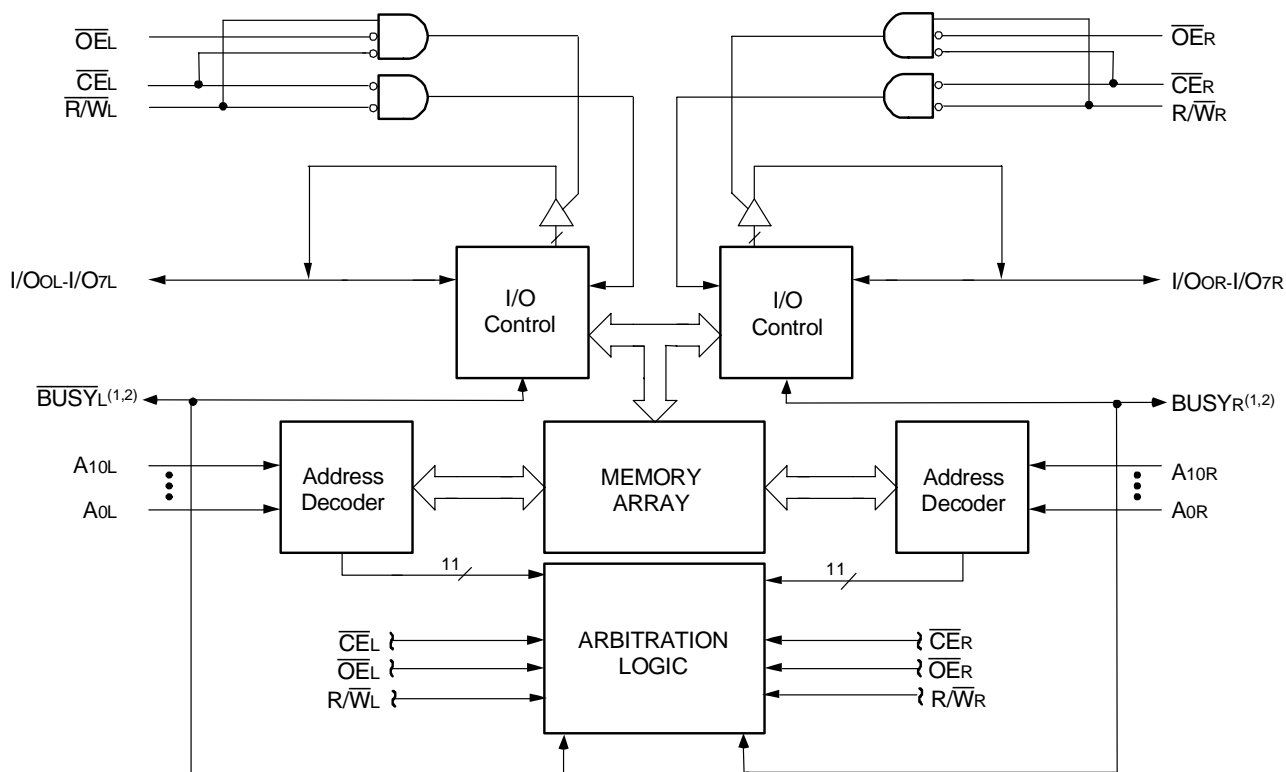

2692 drw 01

**NOTES:**

1. IDT7132 (MASTER):  $\overline{\text{BUSY}}$  is open drain output and requires pullup resistor of 270 $\Omega$ .  
IDT7142 (SLAVE):  $\overline{\text{BUSY}}$  is input.
2. Open drain output: requires pullup resistor of 270 $\Omega$ .

**JUNE 2004**

## Description

The IDT7132/IDT7142 are high-speed 2Kx8 Dual-Port Static RAMs. The IDT7132 is designed to be used as a stand-alone 8-bit Dual-Port RAM or as a "MASTER" Dual-Port RAM together with the IDT7142 "SLAVE" Dual-Port in 16-bit-or-more word width systems. Using the IDT MASTER/SLAVE Dual-Port RAM approach in 16-or-more-bit memory system applications results in full-speed, error-free operation without the need for additional discrete logic.

Both devices provide two independent ports with separate control, address, and I/O pins that permit independent, asynchronous access for reads or writes to any location in memory. An automatic power down feature, controlled by  $\overline{CE}$  permits the on-chip circuitry of each port to enter

a very low standby power mode.

Fabricated using IDT's CMOS high-performance technology, these devices typically operate on only 325mW of power. Low-power (LA) versions offer battery backup data retention capability, with each Dual-Port typically consuming 200 $\mu$ W from a 2V battery.

The IDT7132/7142 devices are packaged in a 48-pin sidebraze or plastic DIPs, 48-pin LCCs, 52-pin PLCCs, and 48-lead flatpacs. Military grade product is manufactured in compliance with the latest revision of MIL-PRF-38535 QML, making it ideally suited to military temperature applications demanding the highest level of performance and reliability.

## Pin Configurations<sup>(1,2,3)</sup>

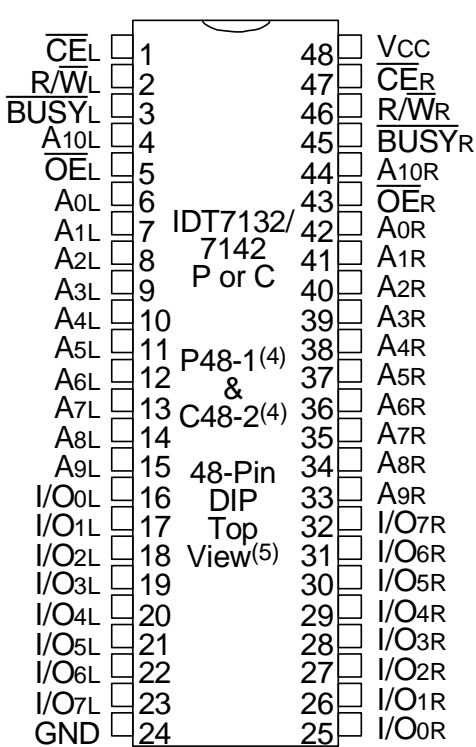

2692 drw 02

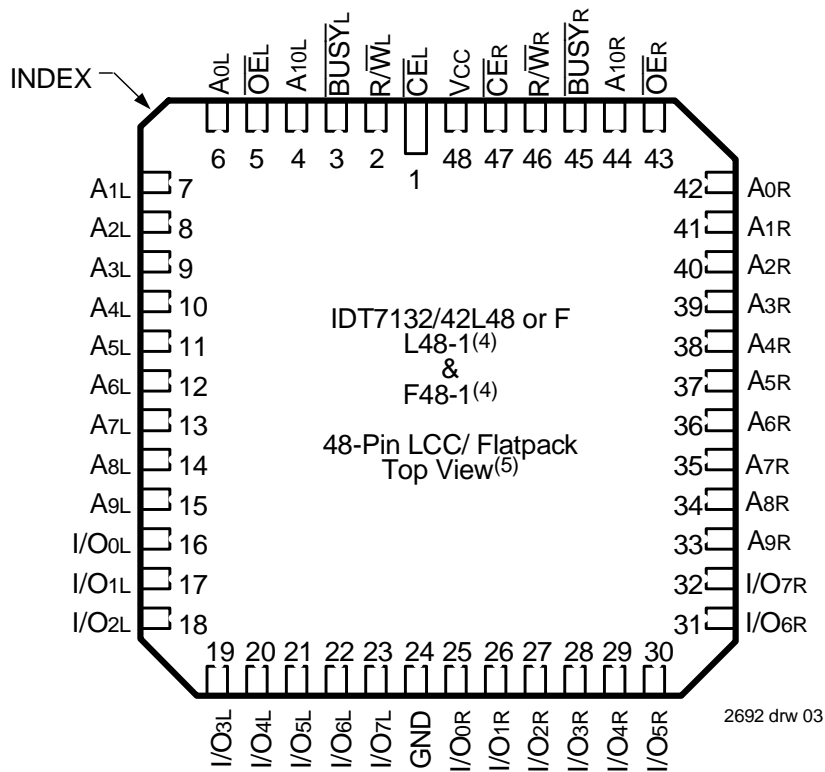

2692 drw 03

### NOTES:

- All Vcc pins must be connected to the power supply.
- All GND pins must be connected to the ground supply.
- P48-1 package body is approximately .55 in x 2.43 in x .18 in.  
C48-2 package body is approximately .62 in x 2.43 in x .15 in.  
L48-1 package body is approximately .57 in x .57 in x .68 in.  
F48-1 package body is approximately .75 in x .75 in x .11 in.
- This package code is used to reference the package diagram.
- This text does not indicate orientation of the actual part-marking.

## Capacitance<sup>(1)</sup> (TA = +25°C, f = 1.0MHz)

Symbol	Parameter	Conditions <sup>(2)</sup>	Max.	Unit
CIN	Input Capacitance	VIN = 3dV	11	pF
COU	Output Capacitance	VOU = 3dV	11	pF

2692 tbl 00

### NOTES:

- This parameter is determined by device characterization but is not production tested.
- 3dV represents the interpolated capacitance when the input and output signals switch from 3V to 0V.

## Pin Configurations<sup>(1,2,3)</sup> (con't.)

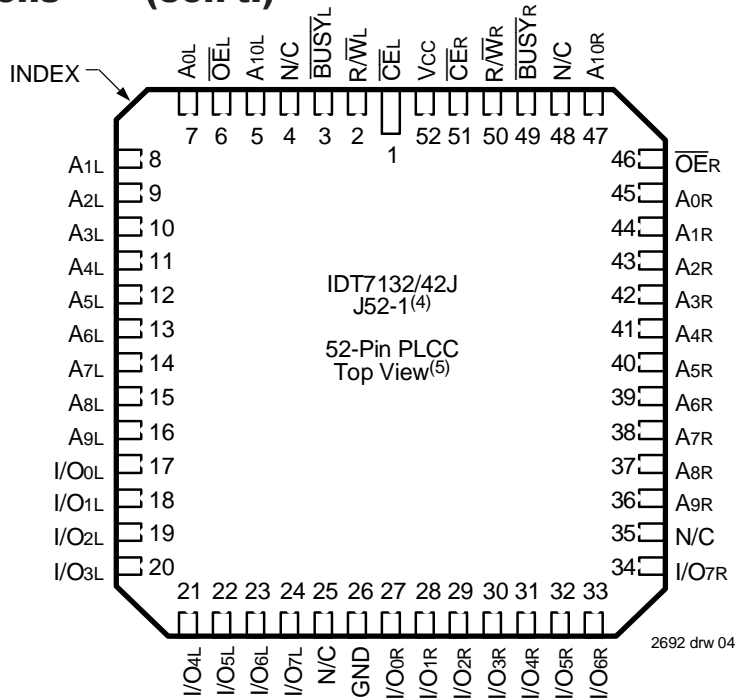

### NOTES:

1. All VCC pins must be connected to the power supply.
2. All GND pins must be connected to the ground supply.
3. Package body is approximately .75 in x .75 in x .17 in.
4. This package code is used to reference the package diagram.
5. This text does not indicate orientation of the actual part-marking.

## Absolute Maximum Ratings<sup>(1)</sup>

Symbol	Rating	Commercial & Industrial	Military	Unit
VTERM <sup>(2)</sup>	Terminal Voltage with Respect to GND	-0.5 to +7.0	-0.5 to +7.0	V
TBIAS	Temperature Under Bias	-55 to +125	-65 to +135	°C
TSTG	Storage Temperature	-65 to +150	-65 to +150	°C
IOUT	DC Output Current	50	50	mA

2692 tbl 01

### NOTES:

1. Stresses greater than those listed under ABSOLUTE MAXIMUM RATINGS may cause permanent damage to the device. This is a stress rating only and functional operation of the device at these or any other conditions above those indicated in the operational sections of the specification is not implied. Exposure to absolute maximum rating conditions for extended periods may affect reliability.
2. VTERM must not exceed VCC + 10% for more than 25% of the cycle time or 10ns maximum, and is limited to ≤ 20mA for the period of VTERM ≥ VCC + 10%.

## Recommended Operating Temperature and Supply Voltage<sup>(1,2)</sup>

Grade	Ambient Temperature	GND	VCC
Military	-55°C to +125°C	0V	5.0V ± 10%
Commercial	0°C to +70°C	0V	5.0V ± 10%
Industrial	-40°C to +85°C	0V	5.0V ± 10%

2692 tbl 02

### NOTES:

1. This is the parameter TA. This is the "instant on" case temperature.
2. Industrial temperature: for specific speeds, packages and powers contact your sales office.

## Recommended DC Operating Conditions

Symbol	Parameter	Min.	Typ.	Max.	Unit
VCC	Supply Voltage	4.5	5.0	5.5	V
GND	Ground	0	0	0	V
VIH	Input High Voltage	2.2	—	6.0 <sup>(2)</sup>	V
VIL	Input Low Voltage	-0.5 <sup>(1)</sup>	—	0.8	V

2692 tbl 03

### NOTES:

1. VIL (min.) = -1.5V for pulse width less than 10ns.
2. VTERM must not exceed VCC + 10%.

## DC Electrical Characteristics Over the Operating Temperature and Supply Voltage Range<sup>(1,5,8)</sup> (V<sub>CC</sub> = 5.0V ± 10%)

Symbol	Parameter	Test Condition	Version	7132X20 <sup>(2)</sup> 7142X20 <sup>(2)</sup> Com'l Only		7132X25 <sup>(7)</sup> 7142X25 <sup>(7)</sup> Com'l, Ind & Military		7132X35 7142X35 Com'l & Military		Unit	
				Typ.	Max.	Typ.	Max.	Typ.	Max.		
I <sub>CC</sub>	Dynamic Operating Current (Both Ports Active)	$\overline{CE}_L = \overline{CE}_R = V_{IL}$ , Outputs Disabled $f = f_{MAX}^{(3)}$	COM'L	SA	110	250	110	220	80	165	mA
				LA	110	200	110	170	80	120	
I <sub>SB1</sub>	Standby Current (Both Ports - TTL Level Inputs)	$\overline{CE}_L = \overline{CE}_R = V_{IH}$ , $f = f_{MAX}^{(3)}$	MIL & IND	SA	—	—	110	280	80	230	mA
				LA	—	—	110	220	80	170	
I <sub>SB1</sub>	Standby Current (Both Ports - TTL Level Inputs)	$\overline{CE}_L = \overline{CE}_R = V_{IH}$ , $f = f_{MAX}^{(3)}$	COM'L	SA	30	65	30	65	25	65	mA
				LA	30	45	30	45	25	45	
I <sub>SB2</sub>	Standby Current (One Port - TTL Level Inputs)	$\overline{CE}^*A = V_{IL}$ and $\overline{CE}^*B = V_{IH}^{(6)}$ Active Port Outputs Disabled $f = f_{MAX}^{(3)}$	MIL & IND	SA	—	—	30	80	25	80	mA
				LA	—	—	30	60	25	60	
I <sub>SB2</sub>	Standby Current (One Port - TTL Level Inputs)	$\overline{CE}^*A = V_{IL}$ and $\overline{CE}^*B = V_{IH}^{(6)}$ Active Port Outputs Disabled $f = f_{MAX}^{(3)}$	COM'L	SA	65	165	65	150	50	125	mA
				LA	65	125	65	115	50	90	
I <sub>SB3</sub>	Full Standby Current (Both Ports - All CMOS Level Inputs)	$\overline{CE}_L$ and $\overline{CE}_R \geq V_{CC} - 0.2V$ $V_{IN} \geq V_{CC} - 0.2V$ or $V_{IN} \leq 0.2V$ , $f = 0^{(4)}$	MIL & IND	SA	—	—	1.0	30	1.0	30	mA
				LA	—	—	1.0	10	0.2	10	
I <sub>SB3</sub>	Full Standby Current (Both Ports - All CMOS Level Inputs)	$\overline{CE}_L$ and $\overline{CE}_R \geq V_{CC} - 0.2V$ $V_{IN} \geq V_{CC} - 0.2V$ or $V_{IN} \leq 0.2V$ , $f = 0^{(4)}$	COM'L	SA	1.0	15	1.0	15	1.0	15	mA
				LA	0.2	5	0.2	5	0.2	4	
I <sub>SB4</sub>	Full Standby Current (One Port - All CMOS Level Inputs)	$\overline{CE}^*A \leq 0.2V$ and $\overline{CE}^*B \geq V_{CC} - 0.2V^{(6)}$ $V_{IN} \geq V_{CC} - 0.2V$ or $V_{IN} \leq 0.2V$ Active Port Outputs Disabled $f = f_{MAX}^{(3)}$	MIL & IND	SA	—	—	60	145	45	110	mA
				LA	—	—	60	105	45	85	
I <sub>SB4</sub>	Full Standby Current (One Port - All CMOS Level Inputs)	$\overline{CE}^*A \leq 0.2V$ and $\overline{CE}^*B \geq V_{CC} - 0.2V^{(6)}$ $V_{IN} \geq V_{CC} - 0.2V$ or $V_{IN} \leq 0.2V$ Active Port Outputs Disabled $f = f_{MAX}^{(3)}$	COM'L	SA	60	155	60	145	45	110	mA
				LA	60	115	60	105	45	85	

2692 tbl 04a

Symbol	Parameter	Test Condition	Version	7132X55 7142X55 Com'l & Military		7132X100 7142X100 Com'l & Military		Unit	
				Typ.	Max.	Typ.	Max.		
I <sub>CC</sub>	Dynamic Operating Current (Both Ports Active)	$\overline{CE}_L = \overline{CE}_R = V_{IL}$ , Outputs Disabled $f = f_{MAX}^{(3)}$	COM'L	SA	65	155	65	155	mA
				LA	65	110	65	110	
I <sub>SB1</sub>	Standby Current (Both Ports - TTL Level Inputs)	$\overline{CE}_L = \overline{CE}_R = V_{IH}$ , $f = f_{MAX}^{(3)}$	MIL & IND	SA	65	190	65	190	mA
				LA	65	140	65	140	
I <sub>SB1</sub>	Standby Current (Both Ports - TTL Level Inputs)	$\overline{CE}_L = \overline{CE}_R = V_{IH}$ , $f = f_{MAX}^{(3)}$	COM'L	SA	20	65	20	55	mA
				LA	20	35	20	35	
I <sub>SB2</sub>	Standby Current (One Port - TTL Level Inputs)	$\overline{CE}^*A = V_{IL}$ and $\overline{CE}^*B = V_{IH}^{(6)}$ Active Port Outputs Disabled $f = f_{MAX}^{(3)}$	MIL & IND	SA	—	—	20	65	mA
				LA	—	—	20	45	
I <sub>SB2</sub>	Standby Current (One Port - TTL Level Inputs)	$\overline{CE}^*A = V_{IL}$ and $\overline{CE}^*B = V_{IH}^{(6)}$ Active Port Outputs Disabled $f = f_{MAX}^{(3)}$	COM'L	SA	40	110	40	110	mA
				LA	40	75	40	75	
I <sub>SB3</sub>	Full Standby Current (Both Ports - All CMOS Level Inputs)	$\overline{CE}_L$ and $\overline{CE}_R \geq V_{CC} - 0.2V$ $V_{IN} \geq V_{CC} - 0.2V$ or $V_{IN} \leq 0.2V$ , $f = 0^{(4)}$	MIL & IND	SA	—	—	1.0	30	mA
				LA	—	—	1.0	10	
I <sub>SB3</sub>	Full Standby Current (Both Ports - All CMOS Level Inputs)	$\overline{CE}_L$ and $\overline{CE}_R \geq V_{CC} - 0.2V$ $V_{IN} \geq V_{CC} - 0.2V$ or $V_{IN} \leq 0.2V$ , $f = 0^{(4)}$	COM'L	SA	1.0	15	1.0	15	mA
				LA	0.2	4	0.2	4	
I <sub>SB4</sub>	Full Standby Current (One Port - All CMOS Level Inputs)	$\overline{CE}^*A \leq 0.2V$ and $\overline{CE}^*B \geq V_{CC} - 0.2V^{(6)}$ $V_{IN} \geq V_{CC} - 0.2V$ or $V_{IN} \leq 0.2V$ Active Port Outputs Disabled $f = f_{MAX}^{(3)}$	MIL & IND	SA	—	—	40	95	mA
				LA	—	—	40	70	
I <sub>SB4</sub>	Full Standby Current (One Port - All CMOS Level Inputs)	$\overline{CE}^*A \leq 0.2V$ and $\overline{CE}^*B \geq V_{CC} - 0.2V^{(6)}$ $V_{IN} \geq V_{CC} - 0.2V$ or $V_{IN} \leq 0.2V$ Active Port Outputs Disabled $f = f_{MAX}^{(3)}$	COM'L	SA	40	100	40	95	mA
				LA	40	70	40	70	
I <sub>SB4</sub>	Full Standby Current (One Port - All CMOS Level Inputs)	$\overline{CE}^*A \leq 0.2V$ and $\overline{CE}^*B \geq V_{CC} - 0.2V^{(6)}$ $V_{IN} \geq V_{CC} - 0.2V$ or $V_{IN} \leq 0.2V$ Active Port Outputs Disabled $f = f_{MAX}^{(3)}$	MIL & IND	SA	40	110	40	110	mA
				LA	40	85	40	80	

2692 tbl 04b

### NOTES:

- 'X' in part numbers indicates power rating (SA or LA).
- PLCC Package only
- At  $f = f_{MAX}$ , address and control lines (except Output Enable) are cycling at the maximum frequency read cycle of 1/trc, and using "AC TEST CONDITIONS" of input levels of GND to 3V.
- $f = 0$  means no address or control lines change. Applies only to inputs at CMOS level standby.
- V<sub>CC</sub> = 5V, T<sub>A</sub> = +25°C for Typ and is not production tested. V<sub>CC DC</sub> = 100mA (Typ)
- Port "A" may be either left or right port. Port "B" is opposite from port "A".
- Not available in DIP packages.
- Industrial temperature: for specific speeds, packages and powers contact your sales office.

### DC Electrical Characteristics Over the Operating Temperature Supply Voltage Range ( $V_{CC} = 5.0V \pm 10\%$ )

Symbol	Parameter	Test Conditions	7132SA 7142SA		7132LA 7142LA		Unit
			Min.	Max.	Min.	Max.	
$ I_{LI} $	Input Leakage Current <sup>(1)</sup>	$V_{CC} = 5.5V,$ $V_{IN} = 0V$ to $V_{CC}$	—	10	—	5	$\mu A$
$ I_{LO} $	Output Leakage Current	$V_{CC} = 5.5V,$ $\overline{CE} = V_{IH}, V_{OUT} = 0V$ to $V_{CC}$	—	10	—	5	$\mu A$
$V_{OL}$	Output Low Voltage	$I_{OL} = 4mA$	—	0.4	—	0.4	V
$V_{OL}$	Open Drain Output Low Voltage (BUSY)	$I_{OL} = 16mA$	—	0.5	—	0.5	V
$V_{OH}$	Output High Voltage	$I_{OH} = -4mA$	2.4	—	2.4	—	V

2692 tbl 05

**NOTE:**

- At  $V_{CC} \leq 2.0V$  leakages are undefined.

### Data Retention Characteristics (LA Version Only)

Symbol	Parameter	Test Condition	Min.	Typ. <sup>(1)</sup>	Max.	Unit	
$V_{DR}$	$V_{CC}$ for Data Retention	$V_{CC} = 2.0V$	2.0	—	—	V	
$I_{CCDR}$	Data Retention Current	$\overline{CE} \geq V_{CC} - 0.2V$ $V_{IN} \geq V_{CC} - 0.2V$ or	Mil. & Ind.	—	100	4000	$\mu A$
			Com'l.	—	100	1500	$\mu A$
$t_{CDR}^{(3)}$	Chip Deselect to Data Retention Time	$V_{IN} \leq 0.2V$	0	—	—	ns	
$t_R^{(3)}$	Operation Recovery Time		$t_{RC}^{(2)}$	—	—	ns	

2692 tbl 06

**NOTES:**

- $V_{CC} = 2V$ ,  $T_A = +25^\circ C$ , and is not production tested.
- $t_{RC}$  = Read Cycle Time
- This parameter is guaranteed but not production tested.

### Data Retention Waveform

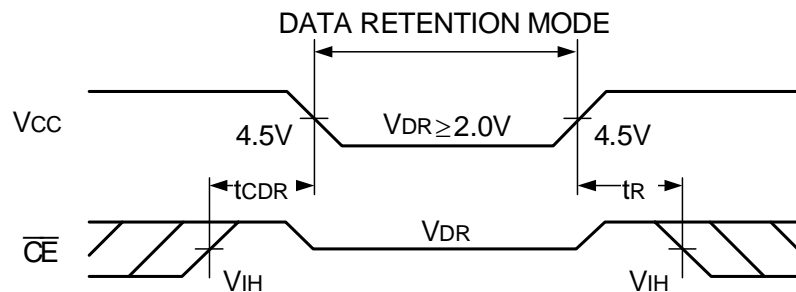

2692 drw 05

## AC Test Conditions

Input Pulse Levels	GND to 3.0V
Input Rise/Fall Times	3ns Max.
Input Timing Reference Levels	1.5V
Output Reference Levels	1.5V
Output Load	Figures 1, 2, and 3

2692 tbl 07

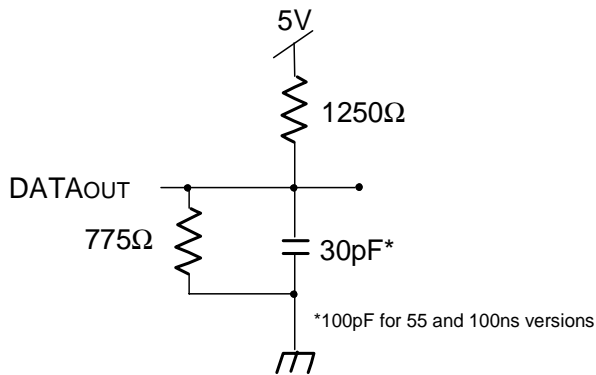

Figure 1. AC Output Test Load

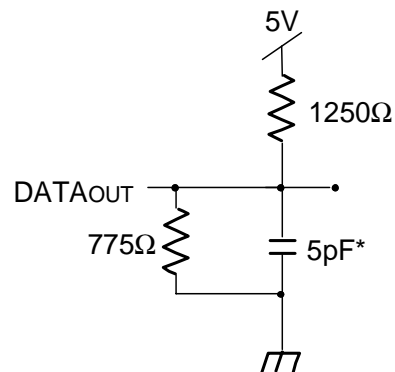

Figure 2. Output Test Load  
(for t<sub>HZ</sub>, t<sub>LZ</sub>, t<sub>wz</sub>, and t<sub>ow</sub>)

\* Including scope and jig

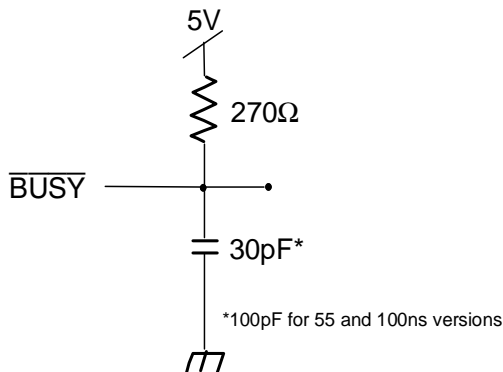

Figure 3.  $\overline{\text{BUSY}}$  AC Output Test Load

2692 drw 06

## AC Electrical Characteristics Over the Operating Temperature and Supply Voltage Range<sup>(3,5)</sup>

Symbol	Parameter	7132X20 <sup>(2)</sup> 7142X20 <sup>(2)</sup> Com'l Only		7132X25 <sup>(2)</sup> 7142X25 <sup>(2)</sup> Com'l, Ind & Military		7132X35 7142X35 Com'l & Military		Unit
		Min.	Max.	Min.	Max.	Min.	Max.	
<b>READ CYCLE</b>								
t <sub>RC</sub>	Read Cycle Time	20	—	25	—	35	—	ns
t <sub>AA</sub>	Address Access Time	—	20	—	25	—	35	ns
t <sub>ACE</sub>	Chip Enable Access Time	—	20	—	25	—	35	ns
t <sub>AOE</sub>	Output Enable Access Time	—	11	—	12	—	20	ns
t <sub>OH</sub>	Output Hold from Address Change	3	—	3	—	3	—	ns
t <sub>LZ</sub>	Output Low-Z Time <sup>(1,4)</sup>	0	—	0	—	0	—	ns
t <sub>HZ</sub>	Output High-Z Time <sup>(1,4)</sup>	—	10	—	10	—	15	ns
t <sub>PU</sub>	Chip Enable to Power Up Time <sup>(4)</sup>	0	—	0	—	0	—	ns
t <sub>PD</sub>	Chip Disable to Power Down Time <sup>(4)</sup>	—	20	—	25	—	35	ns

2692 tbl 08a

Symbol	Parameter	7132X55 7142X55 Com'l & Military		7132X100 7142X100 Com'l & Military		Unit
		Min.	Max.	Min.	Max.	
<b>READ CYCLE</b>						
t <sub>RC</sub>	Read Cycle Time	55	—	100	—	ns
t <sub>AA</sub>	Address Access Time	—	55	—	100	ns
t <sub>ACE</sub>	Chip Enable Access Time	—	55	—	100	ns
t <sub>AOE</sub>	Output Enable Access Time	—	25	—	40	ns
t <sub>OH</sub>	Output Hold from Address Change	3	—	10	—	ns
t <sub>LZ</sub>	Output Low-Z Time <sup>(1,4)</sup>	5	—	5	—	ns
t <sub>HZ</sub>	Output High-Z Time <sup>(1,4)</sup>	—	25	—	40	ns
t <sub>PU</sub>	Chip Enable to Power Up Time <sup>(4)</sup>	0	—	0	—	ns
t <sub>PD</sub>	Chip Disable to Power Down Time <sup>(4)</sup>	—	50	—	50	ns

2692 tbl 08b

### NOTES:

1. Transition is measured 0mV from Low or High-Impedance Voltage Output Test Load (Figure 2).
2. PLCC package only.
3. 'X' in part numbers indicates power rating (SA or LA).
4. This parameter is guaranteed by device characterization, but is not production tested.
5. Industrial temperature: for specific speeds, packages and powers contact your sales office.

## Timing Waveform of Read Cycle No. 1, Either Side<sup>(1)</sup>

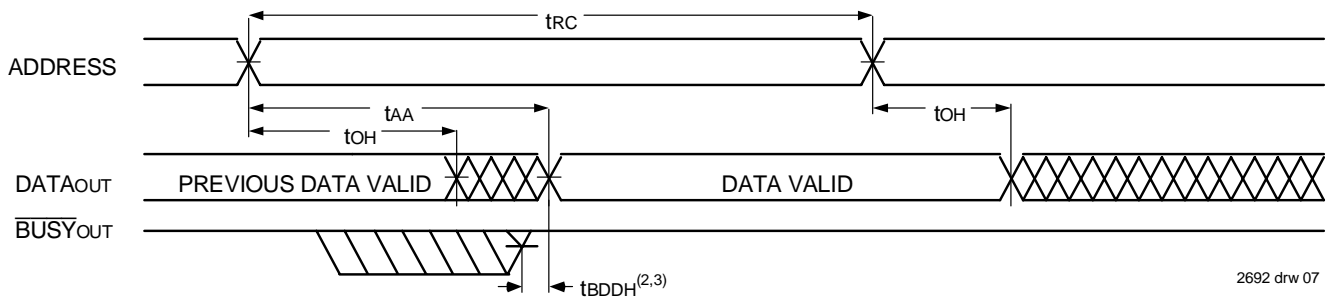

## Timing Waveform of Read Cycle No. 2, Either Side<sup>(1)</sup>

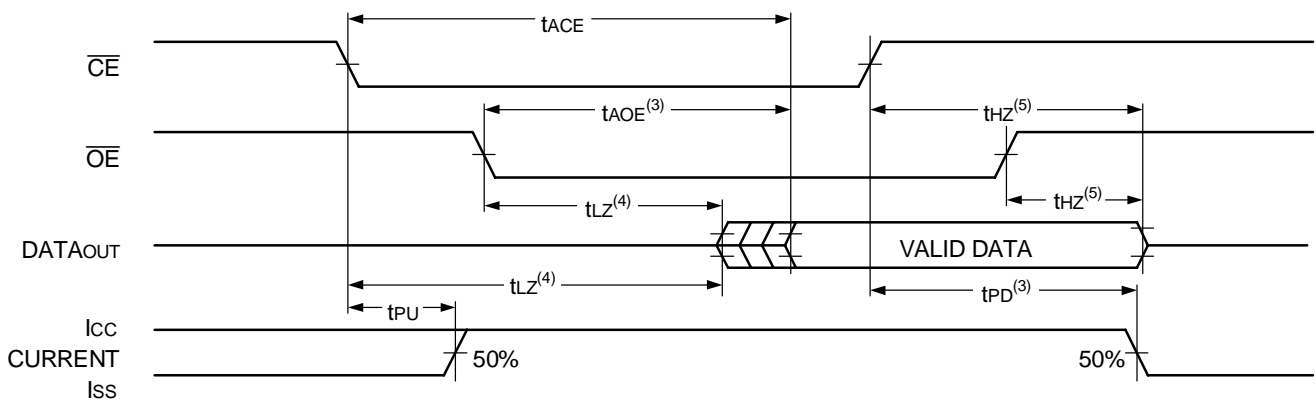

### NOTES:

1.  $\overline{R\overline{W}} = V_{IH}$ ,  $\overline{CE} = V_{IL}$ , and is  $\overline{OE} = V_{IL}$ . Address is valid prior to the coincidental with  $\overline{CE}$  transition LOW.
2.  $t_{BDD}$  delay is required only in the case where the opposite port is completing a write operation to the same address location. For simultaneous read operations,  $\overline{BUSY}$  has no relationship to valid output data.
3. Start of valid data depends on which timing becomes effective last  $t_{AOE}$ ,  $t_{ACE}$ ,  $t_{AA}$ , and  $t_{BDD}$ .
4. Timing depends on which signal is asserted last,  $\overline{OE}$  or  $\overline{CE}$ .
5. Timing depends on which signal is de-asserted first,  $\overline{OE}$  or  $\overline{CE}$ .

## AC Electrical Characteristics Over the Operating Temperature Supply Voltage Range<sup>(5,6)</sup>

Symbol	Parameter	7132X20 <sup>(2)</sup> 7142X20 <sup>(2)</sup> Com'l Only		7132X25 <sup>(2)</sup> 7142X25 <sup>(2)</sup> Com'l, Ind & Military		7132X35 7142X35 Com'l & Military		Unit
		Min.	Max.	Min.	Max.	Min.	Max.	
<b>WRITE CYCLE</b>								
t <sub>WC</sub>	Write Cycle Time <sup>(3)</sup>	20	—	25	—	35	—	ns
t <sub>EW</sub>	Chip Enable to End-of-Write	15	—	20	—	30	—	ns
t <sub>AW</sub>	Address Valid to End-of-Write	15	—	20	—	30	—	ns
t <sub>AS</sub>	Address Set-up Time	0	—	0	—	0	—	ns
t <sub>WP</sub>	Write Pulse Width <sup>(4)</sup>	15	—	15	—	25	—	ns
t <sub>WR</sub>	Write Recovery Time	0	—	0	—	0	—	ns
t <sub>DW</sub>	Data Valid to End-of-Write	10	—	12	—	15	—	ns
t <sub>HZ</sub>	Output High-Z Time <sup>(1)</sup>	—	10	—	10	—	15	ns
t <sub>DH</sub>	Data Hold Time	0	—	0	—	0	—	ns
t <sub>WZ</sub>	Write Enable to Output in High-Z <sup>(1)</sup>	—	10	—	10	—	15	ns
t <sub>OW</sub>	Output Active from End-of-Write <sup>(1)</sup>	0	—	0	—	0	—	ns

2692 tbl 09

Symbol	Parameter	7132X55 7142X55 Com'l & Military		7132X100 7142X100 Com'l & Military		Unit
		Min.	Max.	Min.	Max.	
<b>WRITE CYCLE</b>						
t <sub>WC</sub>	Write Cycle Time <sup>(3)</sup>	55	—	100	—	ns
t <sub>EW</sub>	Chip Enable to End-of-Write	40	—	90	—	ns
t <sub>AW</sub>	Address Valid to End-of-Write	40	—	90	—	ns
t <sub>AS</sub>	Address Set-up Time	0	—	0	—	ns
t <sub>WP</sub>	Write Pulse Width <sup>(4)</sup>	30	—	55	—	ns
t <sub>WR</sub>	Write Recovery Time	0	—	0	—	ns
t <sub>DW</sub>	Data Valid to End-of-Write	20	—	40	—	ns
t <sub>HZ</sub>	Output High-Z Time <sup>(1)</sup>	—	25	—	40	ns
t <sub>DH</sub>	Data Hold Time	0	—	0	—	ns
t <sub>WZ</sub>	Write Enable to Output in High-Z <sup>(1)</sup>	—	30	—	40	ns
t <sub>OW</sub>	Output Active from End-of-Write <sup>(1)</sup>	0	—	0	—	ns

2692 tbl 10

### NOTES:

1. Transition is measured 0mV from Low or High-impedance voltage with Output Test Load (Figure 2). This parameter is guaranteed by device characterization but is not production tested.
2. PLCC package only.
3. For Master/Slave combination, t<sub>WC</sub> = t<sub>BAA</sub> + t<sub>WP</sub>, since R/W =  $\bar{V}_{IL}$  must occur after t<sub>BAA</sub>.
4. If  $\bar{O}E$  is LOW during a R/W controlled write cycle, the write pulse width must be the larger of t<sub>WP</sub> or (t<sub>WZ</sub> + t<sub>DW</sub>) to allow the I/O drivers to turn off data to be placed on the bus for the required t<sub>DW</sub>. If  $\bar{O}E$  is High during a R/W controlled write cycle, this requirement does not apply and the write pulse can be as short as the specified t<sub>WP</sub>.
5. 'X' in part numbers indicates power rating (SA or LA).
6. Industrial temperature: for specific speeds, packages and powers contact your sales office.

### Timing Waveform of Write Cycle No. 1, ( $\overline{R/\overline{W}}$ Controlled Timing)<sup>(1,5,8)</sup>

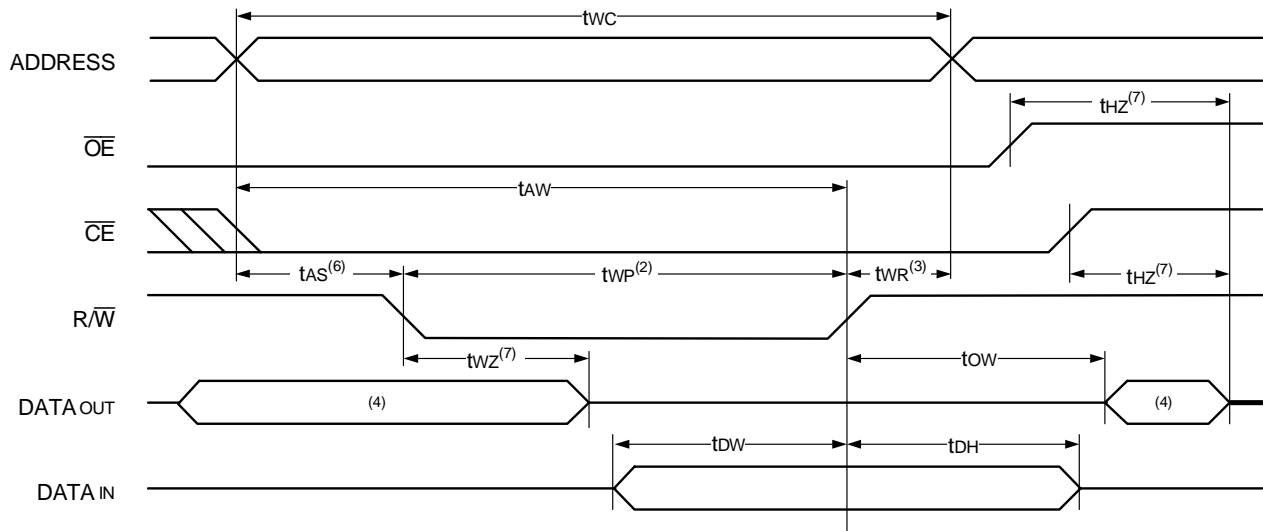

2692 drw 09

### Timing Waveform of Write Cycle No. 2, ( $\overline{CE}$ Controlled Timing)<sup>(1,5)</sup>

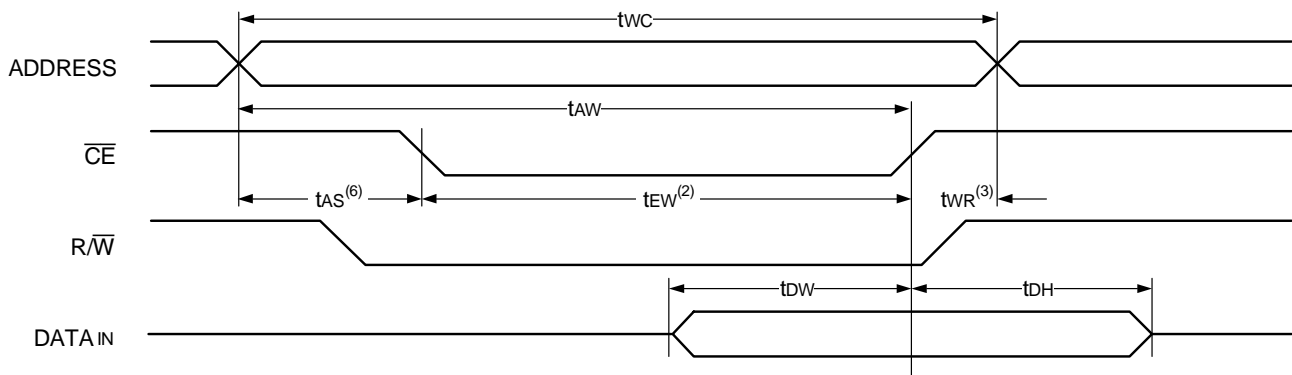

2692 drw 10

**NOTES:**

1.  $\overline{R/\overline{W}}$  or  $\overline{CE}$  must be HIGH during all address transitions.
2. A write occurs during the overlap ( $t_{EW}$  or  $t_{WP}$ ) of  $\overline{CE} = V_{IL}$  and  $\overline{R/\overline{W}} = V_{IL}$ .
3.  $t_{WR}$  is measured from the earlier of  $\overline{CE}$  or  $\overline{R/\overline{W}}$  going HIGH to the end of the write cycle.
4. During this period, the I/O pins are in the output state and input signals must not be applied.
5. If the  $\overline{CE}$  LOW transition occurs simultaneously with or after the  $\overline{R/\overline{W}}$  LOW transition, the outputs remain in the High-impedance state.
6. Timing depends on which enable signal (CE or  $\overline{R/\overline{W}}$ ) is asserted last.
7. This parameter is determined by device characterization, but is not production tested. Transition is measured 0mV from steady state with the Output Test Load (Figure 2).
8. If  $\overline{OE}$  is LOW during a  $\overline{R/\overline{W}}$  controlled write cycle, the write pulse width must be the larger of  $t_{WP}$  or  $(t_{WZ} + t_{OW})$  to allow the I/O drivers to turn off data to be placed on the bus for the required  $t_{OW}$ . If  $\overline{OE}$  is HIGH during a  $\overline{R/\overline{W}}$  controlled write cycle, this requirement does not apply and the write pulse can be as short as the specified  $t_{WP}$ .

## AC Electrical Characteristics Over the Operating Temperature and Supply Voltage Range<sup>(7,8)</sup>

Symbol	Parameter	7132X20 <sup>(1)</sup> 7142X20 <sup>(1)</sup> Com'l Only		7132X25 <sup>(2)</sup> 7142X25 <sup>(2)</sup> Com'l, Ind & Military		7132X35 7142X35 Com'l & Military		Unit
		Min.	Max.	Min.	Max.	Min.	Max.	
<b>BUSY Timing (For Master IDT7132 Only)</b>								
t <sub>BAA</sub>	$\overline{\text{BUSY}}$ Access Time from Address	—	20	—	20	—	20	ns
t <sub>BDA</sub>	$\overline{\text{BUSY}}$ Disable Time from Address	—	20	—	20	—	20	ns
t <sub>BAC</sub>	$\overline{\text{BUSY}}$ Access Time from Chip Enable	—	20	—	20	—	20	ns
t <sub>BDC</sub>	$\overline{\text{BUSY}}$ Disable Time from Chip Enable	—	20	—	20	—	20	ns
t <sub>WDD</sub>	Write Pulse to Data Delay <sup>(2)</sup>	—	50	—	50	—	60	ns
t <sub>WH</sub>	Write Hold After $\overline{\text{BUSY}}$ <sup>(6)</sup>	12	—	15	—	20	—	ns
t <sub>DDD</sub>	Write Data Valid to Read Data Delay <sup>(2)</sup>	—	35	—	35	—	35	ns
t <sub>APS</sub>	Arbitration Priority Set-up Time <sup>(3)</sup>	5	—	5	—	5	—	ns
t <sub>BDD</sub>	$\overline{\text{BUSY}}$ Disable to Valid Data <sup>(4)</sup>	—	25	—	35	—	35	ns
<b>BUSY Timing (For Slave IDT7142 Only)</b>								
t <sub>WB</sub>	Write to $\overline{\text{BUSY}}$ Input <sup>(5)</sup>	0	—	0	—	0	—	ns
t <sub>WH</sub>	Write Hold After $\overline{\text{BUSY}}$ <sup>(6)</sup>	12	—	15	—	20	—	ns
t <sub>WDD</sub>	Write Pulse to Data Delay <sup>(2)</sup>	—	40	—	50	—	60	ns
t <sub>DDD</sub>	Write Data Valid to Read Data Delay <sup>(2)</sup>	—	30	—	35	—	35	ns

2692 tbl 11a

Symbol	Parameter	7132X55 7142X55 Com'l & Military		7132X100 7142X100 Com'l & Military		Unit
		Min.	Max.	Min.	Max.	
<b>BUSY Timing (For Master IDT7132 Only)</b>						
t <sub>BAA</sub>	$\overline{\text{BUSY}}$ Access Time from Address	—	30	—	50	ns
t <sub>BDA</sub>	$\overline{\text{BUSY}}$ Disable Time from Address	—	30	—	50	ns
t <sub>BAC</sub>	$\overline{\text{BUSY}}$ Access Time from Chip Enable	—	30	—	50	ns
t <sub>BDC</sub>	$\overline{\text{BUSY}}$ Disable Time from Chip Enable	—	30	—	50	ns
t <sub>WDD</sub>	Write Pulse to Data Delay <sup>(2)</sup>	—	80	—	120	ns
t <sub>WH</sub>	Write Hold After $\overline{\text{BUSY}}$ <sup>(6)</sup>	20	—	20	—	ns
t <sub>DDD</sub>	Write Data Valid to Read Data Delay <sup>(2)</sup>	—	55	—	100	ns
t <sub>APS</sub>	Arbitration Priority Set-up Time <sup>(3)</sup>	5	—	5	—	ns
t <sub>BDD</sub>	$\overline{\text{BUSY}}$ Disable to Valid Data <sup>(4)</sup>	—	50	—	65	ns
<b>BUSY Timing (For Slave IDT7142 Only)</b>						
t <sub>WB</sub>	Write to $\overline{\text{BUSY}}$ Input <sup>(5)</sup>	0	—	0	—	ns
t <sub>WH</sub>	Write Hold After $\overline{\text{BUSY}}$ <sup>(6)</sup>	20	—	20	—	ns
t <sub>WDD</sub>	Write Pulse to Data Delay <sup>(2)</sup>	—	80	—	120	ns
t <sub>DDD</sub>	Write Data Valid to Read Data Delay <sup>(2)</sup>	—	55	—	100	ns

**NOTES:**

2692 tbl 11b

1. PLCC package only.
2. Port-to-port delay through RAM cells from the writing port to the reading port, refer to "Timing Waveform of Write with Port -to-Port Read and BUSY."
3. To ensure that the earlier of the two ports wins.
4. t<sub>BDD</sub> is a calculated parameter and is the greater of 0, t<sub>WDD</sub> – t<sub>WP</sub> (actual) or t<sub>DDD</sub> – t<sub>DW</sub> (actual).
5. To ensure that a write cycle is inhibited on port "B" during contention on port "A".
6. To ensure that a write cycle is completed on port "B" after contention on port "A".
7. 'X' in part numbers indicates power rating (SA or LA).
8. Industrial temperature: for specific speeds, packages and powers contact your sales office.

### Timing Waveform of Write with Port-to-Port Read and $\overline{\text{BUSY}}^{(2,3,4)}$

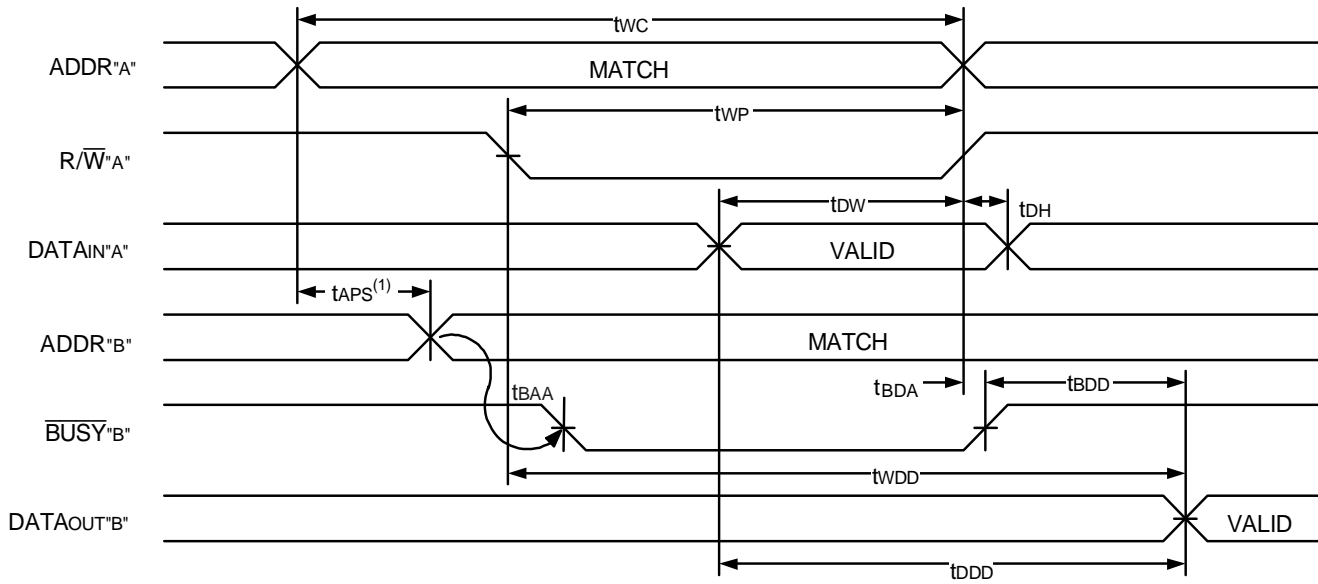

2692 drw 11

**NOTES:**

1. To ensure that the earlier of the two ports wins.  $t_{APS}$  is ignored for Slave (IDT7142).
2.  $\overline{\text{CE}}_L = \overline{\text{CE}}_R = V_{IL}$
3.  $\overline{\text{OE}} = V_{IL}$  for the reading port.
4. All timing is the same for the left and right ports. Port "A" may be either the left or right port. Port "B" is opposite from port "A".

### Timing Waveform of Write with $\overline{\text{BUSY}}^{(4)}$

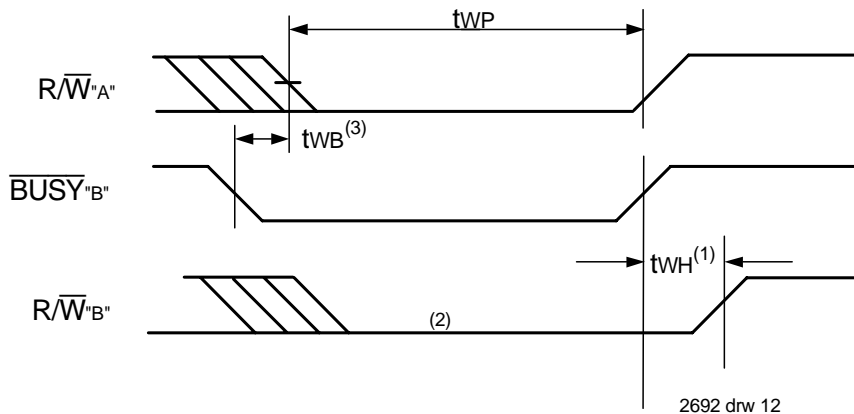

2692 drw 12

**NOTES:**

1.  $t_{WH}$  must be met for both  $\overline{\text{BUSY}}$  Input (IDT7142, slave) or Output (IDT7132, master).
2.  $\overline{\text{BUSY}}$  is asserted on port "B" blocking  $\overline{\text{R/W}}_B$ , until  $\overline{\text{BUSY}}_B$  goes HIGH.
3.  $t_{WB}$  applies only to the slave version (IDT7142).
4. All timing is the same for the left and right ports. Port 'A' may be either the left or right port. Port "B" is opposite from port "A".

## Timing Waveform of $\overline{\text{BUSY}}$ Arbitration Controlled by $\overline{\text{CE}}$ Timing<sup>(1)</sup>

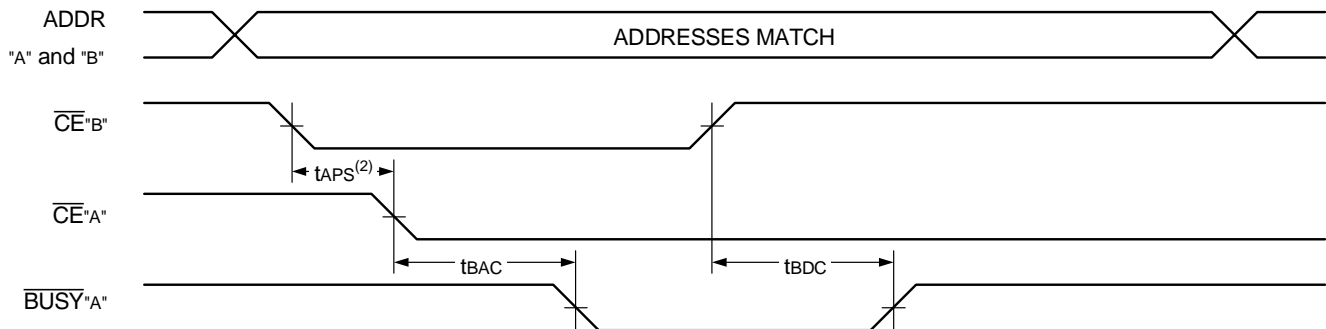

2692 drw 13

## Timing Waveform of $\overline{\text{BUSY}}$ Arbitration Controlled by Address Match Timing<sup>(1)</sup>

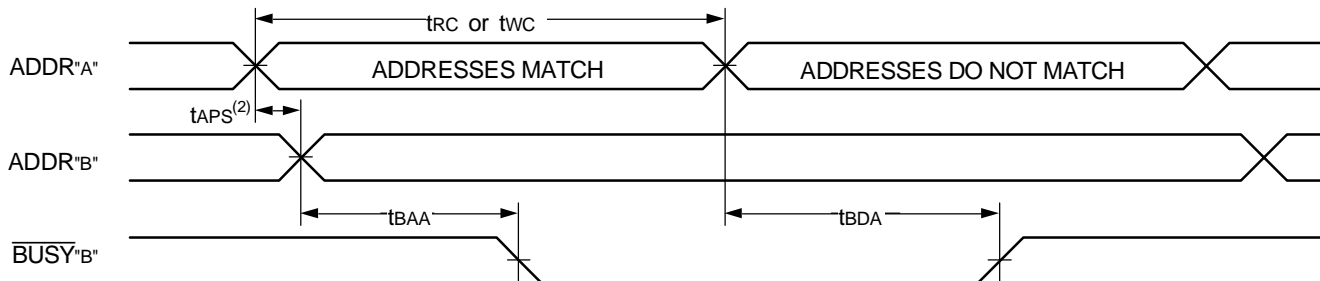

2692 drw 14

### NOTES:

1. All timing is the same for left and right ports. Port "A" may be either left or right port. Port "B" is the opposite from port "A".
2. If tAPS is not satisfied, the  $\overline{\text{BUSY}}$  will be asserted on one side or the other, but there is no guarantee on which side  $\overline{\text{BUSY}}$  will be asserted (7132 only).

## Truth Tables

**Table I. Non-Contention Read/Write Control<sup>(4)</sup>**

Left or Right Port <sup>(1)</sup>				Function
R/W	$\overline{\text{CE}}$	$\overline{\text{OE}}$	D0-7	
X	H	X	Z	Port Disabled and in Power-Down Mode, ISB2 or ISB4
X	H	X	Z	$\overline{\text{CE}}_{\text{R}} = \overline{\text{CE}}_{\text{L}} = V_{\text{IH}}$ , Power-Down Mode, ISB1 or ISB3
L	L	X	DATAIN	Data on Port Written into Memory <sup>(2)</sup>
H	L	L	DATAOUT	Data in Memory Output on Port <sup>(3)</sup>
X	L	H	Z	High Impedance Outputs

2692 tbl 12

### NOTES:

1. A0L - A10L  $\neq$  A0R - A10R
2. If  $\overline{\text{BUSY}} = \text{L}$ , data is not written.
3. If  $\overline{\text{BUSY}} = \text{L}$ , data may not be valid, see twDD and tDD timing.
4. 'H' =  $V_{\text{IH}}$ , 'L' =  $V_{\text{IL}}$ , 'X' = DON'T CARE, 'Z' = HIGH IMPEDANCE

**Table II — Address  $\overline{\text{BUSY}}$  Arbitration**

Inputs			Outputs		Function
$\overline{\text{CE}}_{\text{L}}$	$\overline{\text{CE}}_{\text{R}}$	A0L-A10L A0R-A10R	$\overline{\text{BUSY}}_{\text{L}}^{(1)}$	$\overline{\text{BUSY}}_{\text{R}}^{(1)}$	
X	X	NO MATCH	H	H	Normal
H	X	MATCH	H	H	Normal
X	H	MATCH	H	H	Normal
L	L	MATCH	(2)	(2)	Write Inhibit <sup>(3)</sup>

2692 tbl 13

**NOTES:**

1. Pins  $\overline{\text{BUSY}}_{\text{L}}$  and  $\overline{\text{BUSY}}_{\text{R}}$  are both outputs for IDT7132 (master). Both are inputs for IDT7142 (slave).  $\overline{\text{BUSY}}_{\text{x}}$  outputs on the IDT7132 are open drain, not push-pull outputs. On slaves the  $\overline{\text{BUSY}}_{\text{x}}$  input internally inhibits writes.
2. 'L' if the inputs to the opposite port were stable prior to the address and enable inputs of this port. 'H' if the inputs to the opposite port became stable after the address and enable inputs of this port. If t<sub>APS</sub> is not met, either  $\overline{\text{BUSY}}_{\text{L}}$  or  $\overline{\text{BUSY}}_{\text{R}}$  = LOW will result.  $\overline{\text{BUSY}}_{\text{L}}$  and  $\overline{\text{BUSY}}_{\text{R}}$  outputs can not be LOW simultaneously.
3. Writes to the left port are internally ignored when  $\overline{\text{BUSY}}_{\text{L}}$  outputs are driving LOW regardless of actual logic level on the pin. Writes to the right port are internally ignored when  $\overline{\text{BUSY}}_{\text{R}}$  outputs are driving LOW regardless of actual logic level on the pin.

**Functional Description**

The IDT7132/IDT7142 provides two ports with separate control, address and I/O pins that permit independent access for reads or writes to any location in memory. The IDT7132/IDT7142 has an automatic power down feature controlled by  $\overline{\text{CE}}$ . The  $\overline{\text{CE}}$  controls on-chip power down circuitry that permits the respective port to go into a standby mode when not selected ( $\overline{\text{CE}} = \text{V}_{\text{IH}}$ ). When a port is enabled, access to the entire memory array is permitted.

**Busy Logic**

Busy Logic provides a hardware indication that both ports of the RAM have accessed the same location at the same time. It also allows one of the two accesses to proceed and signals the other side that the RAM is "Busy". The  $\overline{\text{BUSY}}$  pin can then be used to stall the access until the operation on the other side is completed. If a write operation has been attempted from the side that receives a busy indication, the write signal is gated internally to prevent the write from proceeding.

The use of  $\overline{\text{BUSY}}$  Logic is not required or desirable for all applications. In some cases it may be useful to logically OR the  $\overline{\text{BUSY}}$  outputs together and use any  $\overline{\text{BUSY}}$  indication as an interrupt source to flag the event of an illegal or illogical operation.

The  $\overline{\text{BUSY}}$  outputs on the IDT7132 RAM master are totem-pole type outputs and do not require pull-up resistors to operate. If these RAMs are being expanded in depth, then the  $\overline{\text{BUSY}}$  indication for the resulting array does not require the use of an external AND gate.

**Width Expansion with Busy Logic Master/Slave Arrays**

When expanding an SRAM array in width while using  $\overline{\text{BUSY}}$  logic, one master part is used to decide which side of the SRAM array will receive a  $\overline{\text{BUSY}}$  indication, and to output that indication. Any number of slaves to be addressed in the same address range as the master, use the  $\overline{\text{BUSY}}$  signal as a write inhibit signal. Thus on the IDT7132/IDT7142 SRAMs the  $\overline{\text{BUSY}}$  pin is an output if the part is Master (IDT7132), and the  $\overline{\text{BUSY}}$  pin is an input if the part is a Slave (IDT7142) as shown in Figure 3.

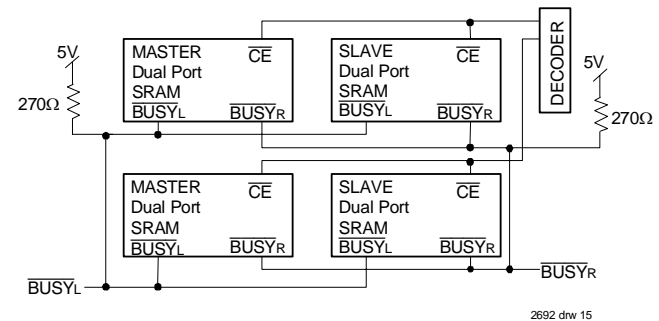
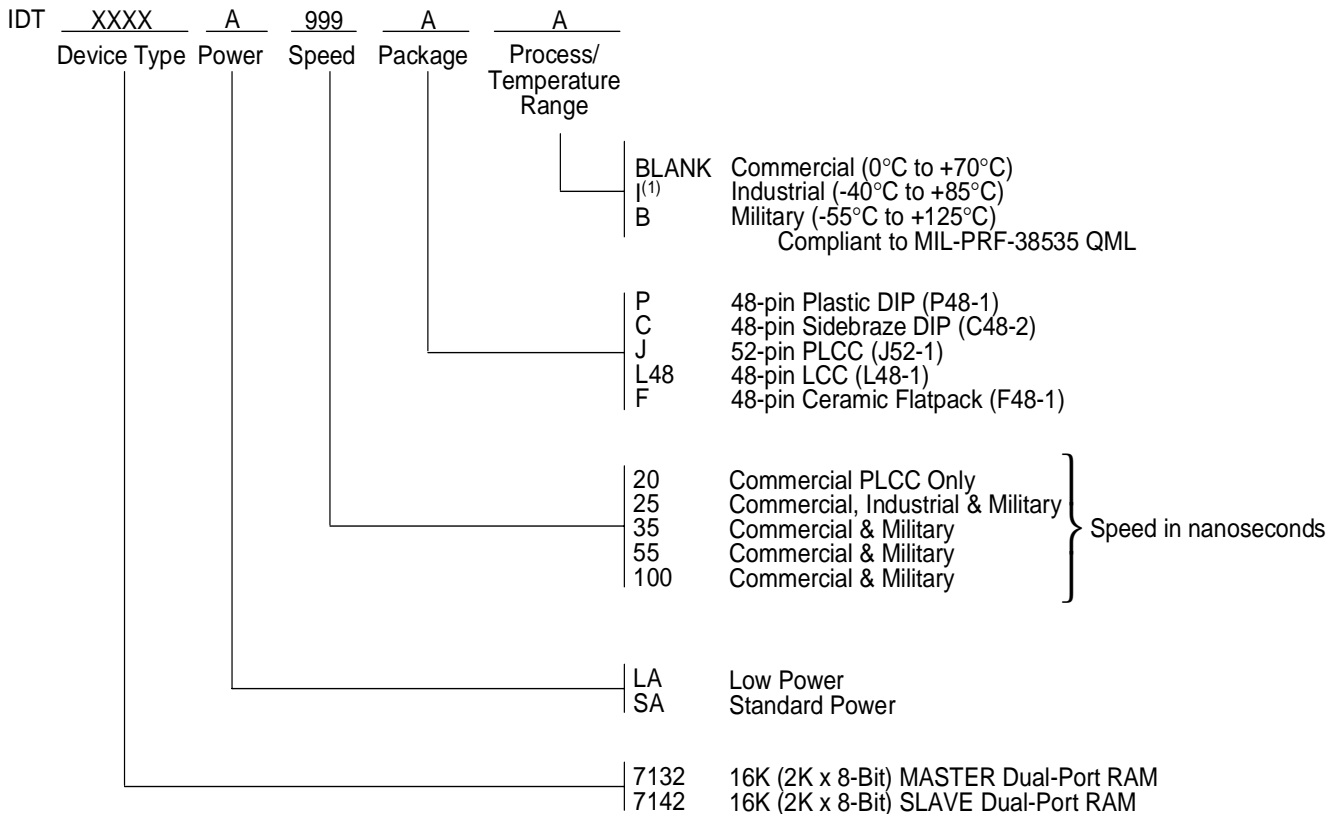

Figure 4. Busy and chip enable routing for both width and depth expansion with IDT7132 (Master) and (Slave) IDT7142 SRAMs.

If two or more master parts were used when expanding in width, a split decision could result with one master indicating  $\overline{\text{BUSY}}$  on one side of the array and another master indicating  $\overline{\text{BUSY}}$  on one other side of the array. This would inhibit the write operations from one port for part of a word and inhibit the write operations from the other port for the other part of the word.

The  $\overline{\text{BUSY}}$  arbitration, on a Master, is based on the chip enable and address signals only. It ignores whether an access is a read or write. In a master/slave array, both address and chip enable must be valid long enough for a  $\overline{\text{BUSY}}$  flag to be output from the master before the actual write pulse can be initiated with either the  $\overline{\text{R}}/\overline{\text{W}}$  signal or the byte enables. Failure to observe this timing can result in a glitched internal write inhibit signal and corrupted data in the slave.

## Ordering Information



**NOTE:**

- Industrial temperature range is available.  
For specific speeds, packages and powers contact your sales office.

2692 drw 16

## Datasheet Document History

- 03/24/99: Initiated datasheet document history  
Converted to new format  
Cosmetic and typographical corrections  
Pages 2 and 3 Added additional notes to pin configurations
- 06/08/99: Changed drawing format
- 08/26/99: Page 14 Changed Busy Logic and Width Expansion copy
- 11/10/99: Replaced IDT logo
- 01/12/00: Pages 1 and 2 Moved full "Description" to page 2 and adjusted page layouts  
Page 1 Added "(LAonly)" to paragraph  
Page 2 Fixed P48-1 body package description  
Page 3 Increased storage temperature parameters  
Clarified TA parameter  
Page 4 DC Electrical parameters—changed wording from "open" to "disabled"  
Page 6 Added asteriks to Figures 1 and 3 in drw 06  
Page 14 Corrected part numbers  
Changed ±500mV to 0mV in notes  
Datasheet Document History continued on page 16

## Datasheet Document History (cont'd)

06/11/04: Page 6 Corrected errors in Figure 3 by changing  $1250\Omega$  to  $270\Omega$  and removing "or Int" and Int  
Page 4, 7, 9, 11 & 15 Clarified Industrial temp offering for 25ns  
Page 5 Removed  $\overline{INT}$  from  $V_{OL}$  parameter in DC Electrical Characteristics table  
Page 6 Updated AC Test Conditions Input Rise/Fall Times from 5ns to 3ns



**CORPORATE HEADQUARTERS**

2975 Stender Way  
Santa Clara, CA 95054

**for SALES:**

800-345-7015 or 408-727-5166  
fax: 408-492-8674  
[www.idt.com](http://www.idt.com)

**for Tech Support:**

831-754-4613  
[DualPortHelp@idt.com](mailto:DualPortHelp@idt.com)

The IDT logo is a registered trademark of Integrated Device Technology, Inc.