

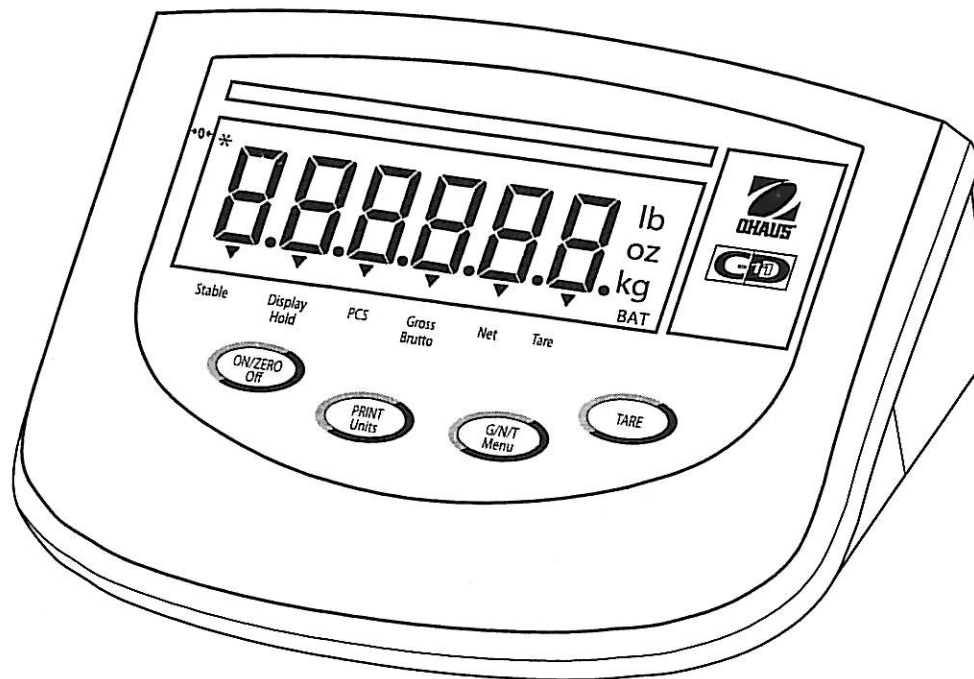

Model CD-11 Indicator Instruction Manual

Indicador Modelo CD-11
Manual de instrucciones

Indicateur modèle CD-11
Manuel d'instruction



FCC Note

This equipment has been tested and found to comply with the limits for a Class A digital device, pursuant to Part 15 of the FCC Rules. These limits are designed to provide reasonable protection against harmful interference in a residential installation. This equipment generates, uses and can radiate radio frequency energy and, if not installed and used in accordance with the instructions, may cause harmful interference to radio communications. However, there is no guarantee that interference will not occur in a particular installation. If this equipment does cause harmful interference to radio or television reception, which can be determined by turning the equipment off and on, the user is encouraged to try to correct the interference by one or more of the following measures:

- Reorient or relocate the receiving antenna.
- Increase the separation between the equipment and receiver.
- Connect the equipment into an outlet on a circuit different from that to which the receiver is connected.
- Consult the dealer or an experienced radio/TV technician for help.

Industry Canada Note

This Class B digital apparatus complies with the Canadian ICES-003.
Cet appareil numérique de la classe B est conforme à la norme NMB-003 du Canada.

ISO 9001 Registration

In 1994, Ohaus Corporation, USA, was awarded a certificate of registration to ISO 9001 by Bureau Veritus Quality International (BVQI), confirming that the Ohaus quality management system is compliant with the ISO 9001 standard's requirements. On May 15, 2003, Ohaus Corporation, USA, was re-registered to the ISO 9001:2000 standard.

Registro ISO 9001

En 1994, Bureau Veritus Quality International (BVQI) le otorgó a Ohaus Corporation, EE.UU., un certificado de registro ISO 9001 el cual confirma que el sistema administrativo de calidad de Ohaus cumple con los requerimientos del estándar ISO 9001. En mayo 15 del 2003, Ohaus Corporation, EE.UU., fue registrada nuevamente al estándar ISO 9001:2000.

Enregistrement ISO 9001

En 1994, le Bureau Veritus Quality International (BVQI) a octroyé la certification d'enregistrement ISO 9001 à Ohaus Corporation, États-Unis d'Amérique, confirmant que le système de gestion de la qualité Ohaus était conforme aux conditions normalisées de l'ISO 9001. Le 15 mai 2003, Ohaus Corporation, États-Unis d'Amérique, a été ré-enregistrée à la norme ISO 9001:2000.

TABLE OF CONTENTS

OVERVIEW OF CONTROLS AND INDICATOR FUNCTIONS	3
1. GETTING TO KNOW YOUR INDICATOR	4
1.1 Introduction	4
1.2 Features.....	4
1.3 Safety precautions	4
2. INSTALLATION	5
2.1 Unpacking and Checking	5
2.2 Selecting the Location	5
2.3 Connecting the Indicator to a Scale Base	5
2.4 Connecting the RS232 Interface.....	7
2.5 Connecting Power	7
2.5.1 AC Adapter	7
2.5.2 Battery Installation	7
2.5.3 Switching on the Indicator	8
2.6 Initial Setup	8
2.6.1 Control Functions	8
2.6.2 Menu Structure	9
2.6.3 Load Parameters	10
2.6.4 Setup Menu	11
2.6.5 Readout Menu	13
2.6.6 Print menu	17
2.6.7 Lockout Menu	19
3. CALIBRATION AND SEALING	21
3.1 Legal for Trade (LFT) Operation and LFT Sealing	25
4. OPERATION	26
4.1 Turning On Indicator	26
4.2 Turning Off Indicator	26
4.3 Zero Operation	26
4.4 Tare Operation	26
4.5 Gross/Net/Tare Recall Operation	27

TABLE OF CONTENTS (Cont.)

4.6 Clear Tare Operation	27
4.7 Unit Switch Operation	27
4.8 Parts Counting Operation	28
4.9 Establishing the Average Piece Weight (APW)	28
4.10 Returning to a Weighing Mode	29
4.11 Returning to a Preset APW	29
4.12 Display Hold Modes	29
4.12.1 Manual Display Hold (dHMA _n)	29
4.12.2 Semi-automatic Display Hold (dHSEM)	30
4.12.3 Automatic Display Hold (dHAuto)	31
4.13 RS232 Commands	31
4.14 Printing Data	32
5. CARE AND MAINTENANCE	33
5.1 Troubleshooting	33
5.2 Error Codes List	35
5.3 Service Information	35
5.4 Replacement Parts	35
5.5 Accessories	35
5.6 Technical Data	35

OVERVIEW OF CONTROLS AND INDICATOR FUNCTIONS

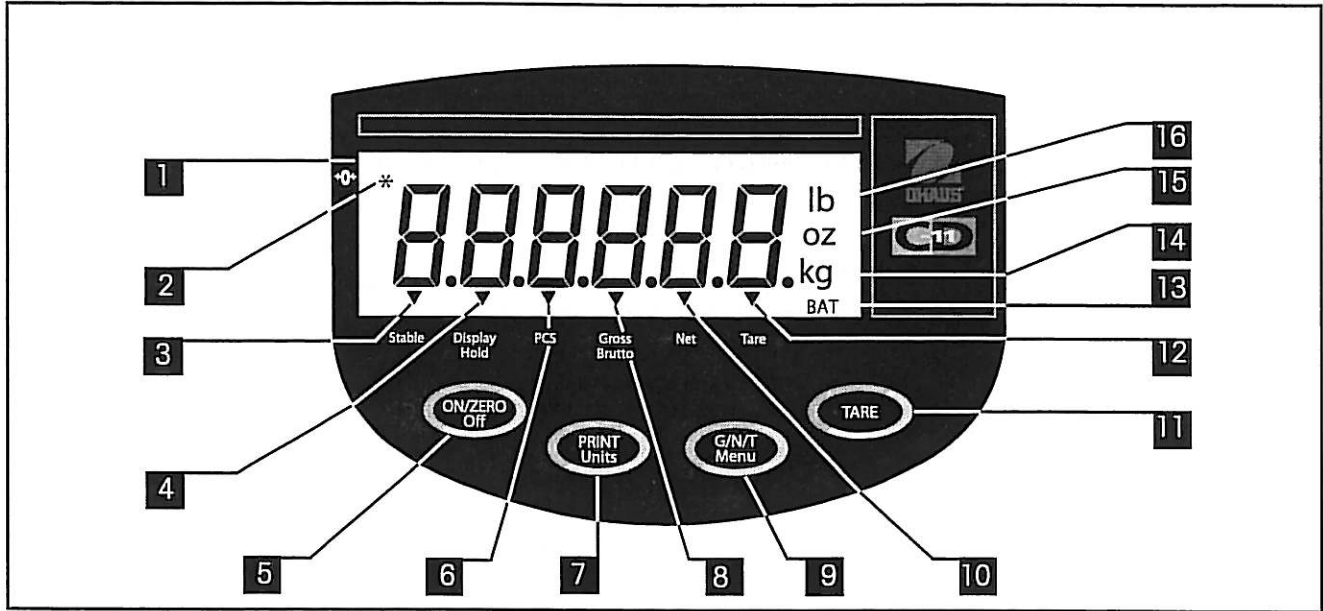

No.	Designation	Function
1	Display	LCD display, indicates weight, modes and setup information.
2	Center of Zero	LCD indicator prompt, indicates center of zero when within +/- 0.25d.
3	Stable	LCD indicator prompt, indicates that the measured value has become stable.
4	Display Hold	LCD indicator prompt, indicates display hold is active.
5	ON/ZERO/Off button	Turns Indicator on or off. Secondary use, provides zero function.
6	Pcs	LCD indicator prompt, indicates parts counting function is active.
7	PRINT/Units button	Short press, prints data which is displayed on the Indicator. Long press, changes unit of measure or mode. When in menus, each press advances through the menus. When in submenus or establishing Average Piece Weights, each press toggles through settings.
8	Gross Brutto	LCD indicator prompt, indicates gross weight.
9	G/N/T/Menu button	Recalls Gross/Net/Tare. Long press allows entry into menus. When in menu, accepts the settings. when in parts counting mode, long press sets up Average Piece Weight.
10	Net	LCD indicator prompt indicates net weight.
11	TARE button	When pressed, enters tare value into memory.
12	Tare	LCD indicator prompt indicates tare weight. When establishing print interval, increments through the settings.
13	BAT	LCD indicator prompt, indicates low battery.
14	kg g	LCD indicator, when lit, indicates weight in kilograms. LCD indicator, when lit, indicates weight in grams.
15	oz	LCD indicator, when lit, indicates weight in ounces.
16	lb	LCD indicator, when lit, indicates weight in pounds.

1. GETTING TO KNOW YOUR INDICATOR

1.1 Introduction

Thank you for deciding to purchase a CD-11 Indicator from Ohaus. The Ohaus CD-11 Indicator is a rugged, reliable, electronic weight indicator designed for easy operation.

Behind your instrument stands OHAUS, a leading manufacturer of precision Indicators, Scales and Balances. An Aftermarket Department with trained instrument technicians is dedicated to providing you with the fastest service possible in the event your instrument requires servicing. OHAUS also has a Customer Service Department to answer any inquiries regarding applications and accessories.

To ensure you make full use of the possibilities offered by your CD-11 Indicator, please read the manual completely before installation and operation.

1.2 Features

Major features include:

- 6 digits, 7-segments, 25 mm high digits; backlit LCD display
- 4 function membrane switch
- Supports up to four (4) 350 ohm analog load cells
- Up to 20,000d displayed resolution
- Flexible unit switching: lb/kg/oz/g
- Capacities from 5 to 20,000 lb/kg
- AC power adapter or 6 Alkaline "C" battery operation
- Power-saving Auto Shut-off timer
- Low battery warning
- Standard built-in RS-232 interface
- Parts Counting or Display Hold modes
- Available table, wall or tower mounting accessories

1.3 Safety Precautions

Model CD-11 Indicator **must not be operated in hazardous areas.**

Before connecting the AC adapter, verify that the voltage printed on it corresponds to the local mains voltage. If this is not the case, please contact your local Ohaus dealer.

Model CD-11 Indicator may only be used in a dry environment.

2. INSTALLATION

2.1 Unpacking and Checking

Open the package and remove the instrument and the accessories. Check the completeness of the delivery. The following accessories are part of the standard equipment of your new Indicator.

Remove packing material from the instrument.

Check the instrument for transport damage. Immediately inform your Ohaus dealer if you have complaints or parts are missing. Your Indicator package should contain:

- Indicator CD-11
- AC Adapter
- Warranty card
- Capacity label
- Screw driver (for terminal connections)
- Instruction Manual
- Sealing Kit
- RS232 connector

Store all parts of the packaging. This packaging guarantees the best possible protection for the transport of your instrument.

2.2 Selecting the Location

The Indicator should be used in an environment which is free from corrosives, vibration, temperature or humidity extremes. These factors will affect displayed weight readings. Scale bases used with the Indicator should be located on a stable level surface and kept away from vibrating sources such as large machinery. Maximum accuracy will be achieved when the area is clean and vibration free.

2.3 Connecting the Indicator to a Scale Base

Turn the Indicator over and using a Phillips screw driver, remove the four screws which secure the rear cover. Two screws are under the battery cover.

Remove the rear cover.

Pass the load cell cable through the liquid tight connector on the left side of the housing.

Refer to the color code of the load cell cable and connect the wires to Terminal Strip J4. Tighten all screws securely.

2.3 Connecting the Indicator to a Scale Base (Cont.)

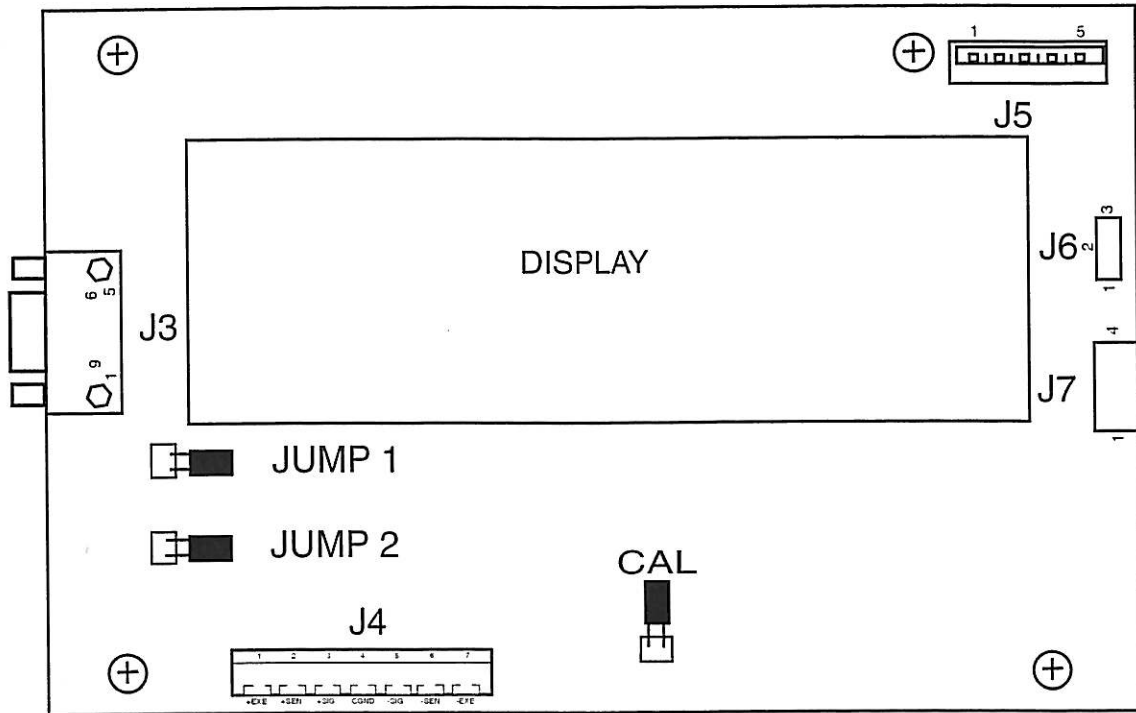

Printed Circuit Board Connector Locations.

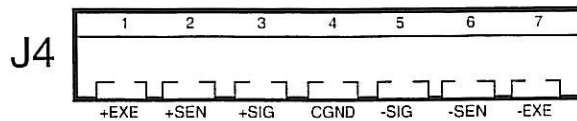

Connector J4 Terminations.

For load cells without sense capability (4-wire), Jump 1 and Jump 2 must be shorted as shown in the illustration.

For load cells with sense capability (6-wire), Jump 1 and Jump 2 must be open.

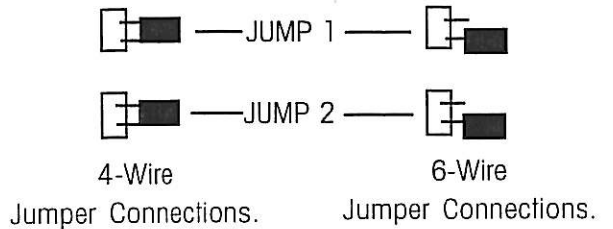

2.4 Connecting the RS232 Interface

CD-11 Indicators are equipped with a standard IBM™ compatible, bi-directional RS232 interface for communication with printers and computers. When the Indicator is connected directly to a printer or a PC, displayed data can be recorded at any time by simply pressing the **Print/Units** button.

Connecting the Indicator to a computer enables you to operate several functions of the Indicator from the computer, as well as receive data such as displayed weight, weighing mode, stability status, etc.

Hardware

A 9-pin female "D" connector located on the left side of the indicator is provided for interfacing to other devices. Pin connections are shown in the adjacent illustration.

1	N/C
2	RXD
3	TXD
4	N/C
5	GND
6	N/C
7	N/C
8	N/C
9	N/C

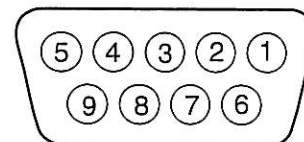

RS-232 Connector Pin Layout.

2.5 Connecting Power

The CD-11 Indicator may be operated using the AC Adapter supplied, or 6 Alkaline C-type batteries (not supplied).

2.5.1 AC Adapter

Connect the AC Adapter connector to the receptacle located at the right-hand side of the Indicator and plug the adapter into a convenient outlet.

NOTICE:



The socket/outlet must be installed near the equipment and shall be easily accessible.

2.5.2 Battery Installation

Open the battery cover on the bottom of the housing.

Insert 6 Alkaline C-type batteries into the two battery sleeves (3 in each sleeve) making sure the batteries are all facing in the same direction.

Place the batteries into the two slots in the housing. Orient the batteries so that the positive (+) ends are against the reeds and the negative (-) ends rest against the springs.

2.5.2 Battery Installation (Cont.)

NOTE: It is recommended that when the CD-11 is operated from batteries, the Auto-Off Timer feature be turned on to extend battery life.

2.5.3 Switching On the Indicator

Once the Indicator and Scale Base are connected and installed, follow the setup procedure outlined below.

Power On/Off

With the Indicator connected to an appropriate power supply, press the **ON/ZERO Off** button. The Indicator performs a self-test, displays the software revision momentarily and then goes to a weighing mode.

At this point, the Indicator is on and ready for initial setup.

Stabilization

Before initially using the Indicator, allow time for it to adjust to its new environment. Recommended warm up period is five (5) minutes.

2.6 Initial Setup

The CD-11 Indicator is equipped with menus which permit certain functions to be locked out (not changed) during operation. If locking out changes to the setup selections, access the CAL jumper located on the circuit board following the setup procedure. Once all setup procedures are completed, reassemble the Indicator. For first time setup, step through all menus and set the parameters as desired. As the last step, enter the CAL menu and calibrate the system.

The Indicator has five menus; CAL (Calibration), SEtUP (Setup), rEAd (Read) , Print (Printing) and LOCSW (Lockswitch) which are entered by pressing and holding the **G/N/T/Menu** button until MEnu is displayed, then releasing it. The display then switches to CAL.

To access the rest of the menus, the **PRINT/Units** button is repeatedly pressed until the desired menu is reached.

2.6.1 Control Functions

During setup, the following buttons are used.

PRINT/Units Button

Change between menus horizontally or change sub-menu parameters.

G/N/T/Menu Button

Press and hold to enter menu. Enters menu and steps through sub-menus vertically.

Tare Button

Change print interval settings.

2.6.2 Menu Structure

The following table illustrates the menu structure in the CD-11 Indicator.

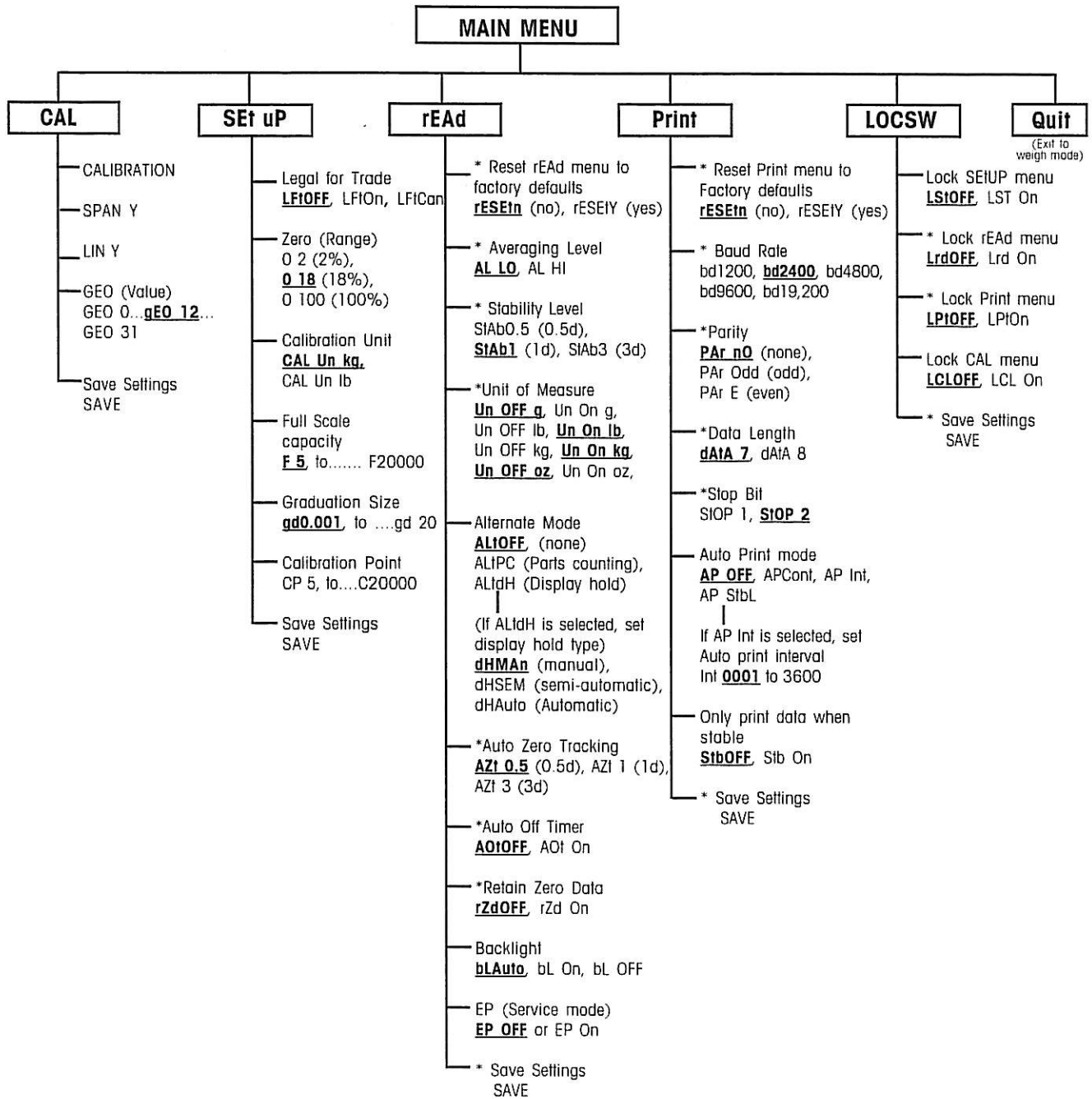

Press (**G/N/T/MENU**) to enter the display submenu or select a displayed setting.

Press (**PRINT/UNITS**) to change the displayed submenu or setting.

Factory default settings are shown in **underlined and boldface** type.

When jumper (CAL) on the circuit board is opened, all of the menus can be reached except CALIBRATION Menu, but only the submenus which are marked '*' can be setup, see menu structure.

2.6.3 Load Cell Setup Parameters

Review the specifications of the scale base to be used with the Indicator. Make sure the settings you select in the indicator are compatible with the scale base. The Capacity (full scale), readability (graduation size) and calibration point (Span and Linearity) selections are shown in the setup table below.

Full Scale Capacity (Fxxxxx)	Graduation Size with LFT OFF (gdxxxx)	Graduation Size with LFT On and LFT CA _n	Span Calibration Point (CPxxxx)	Linearity Calibration Points (not user selectable)
5	0.001, 0.002, 0.005	0.001, 0.002, 0.005	<u>5</u>	2 & 5
10	0.001, 0.002, 0.005, 0.01	0.002, 0.005, 0.01	5, <u>10</u>	5 & 10
15	0.001, 0.002, 0.005, 0.01	0.005, 0.01	5, 10, <u>15</u>	5 & 15
20	0.001, 0.002, 0.005, 0.01, 0.02	0.005, 0.01, 0.02	5, 10, 15, <u>20</u>	10 & 20
25	0.002, 0.005, 0.01, 0.02	0.005, 0.01, 0.02	5, 10, 15, 20, <u>25</u>	10 & 25
30	0.002, 0.005, 0.01, 0.02	0.01, 0.02	5, 10, 15, 20, 25, <u>30</u>	15 & 30
40	0.002, 0.005, 0.01, 0.02	0.01, 0.02	5, 10, 15, 20, 25, 30, <u>40</u>	20 & 40
50	0.005, 0.01, 0.02, 0.05	0.01, 0.02, 0.05	5, 10, 15, 20, 25, 30, 40, <u>50</u>	25 & 50
60	0.005, 0.01, 0.02, 0.05	0.02, 0.05	5, 10, 15, 20, 25, 30, 40, 50, <u>60</u>	30 & 60
75	0.005, 0.01, 0.02, 0.05	0.02, 0.05	5, 10, 15, 20, 25, 30, 40, 50, 60, <u>75</u>	30 & 75
100	0.005, 0.01, 0.02, 0.05, 0.1	0.02, 0.05, 0.1	5, 10, 15, 20, 25, 30, 40, 50, 60, 75, <u>100</u>	50 & 100
120	0.01, 0.02, 0.05, 0.1	0.05, 0.1	5, 10, 15, 20, 25, 30, 40, 50, 60, 75, 100, <u>120</u>	60 & 120
150	0.01, 0.02, 0.05, 0.1	0.05, 0.1	5, 10, 15, 20, 25, 30, 40, 50, 60, 75, 100, 120, <u>150</u>	75 & 150
200	0.01, 0.02, 0.05, 0.1, 0.2	0.05, 0.1, 0.2	5, 10, 15, 20, 25, 30, 40, 50, 60, 75, 100, 120, 150, <u>200</u>	100 & 200
250	0.02, 0.05, 0.1, 0.2	0.05, 0.1, 0.2	5, 10, 15, 20, 25, 30, 40, 50, 60, 75, 100, 120, 150, 200, <u>250</u>	120 & 250
300	0.02, 0.05, 0.1, 0.2	0.1, 0.2	5, 10, 15, 20, 25, 30, 40, 50, 60, 75, 100, 120, 150, 200, 250, <u>300</u>	150 & 300
400	0.02, 0.05, 0.1, 0.2	0.1, 0.2	5, 10, 15, 20, 25, 30, 40, 50, 60, 75, 100, 120, 150, 200, 250, 300, <u>400</u>	200 & 400
500	0.05, 0.1, 0.2, 0.5	0.1, 0.2, 0.5	5, 10, 15, 20, 25, 30, 40, 50, 60, 75, 100, 120, 150, 200, 250, 300, 400, <u>500</u>	250 & 500
600	0.05, 0.1, 0.2, 0.5	0.2, 0.5	5, 10, 15, 20, 25, 30, 40, 50, 60, 75, 100, 120, 150, 200, 250, 300, 400, 500, <u>600</u>	300 & 600
750	0.05, 0.1, 0.2, 0.5	0.2, 0.5	5, 10, 15, 20, 25, 30, 40, 50, 60, 75, 100, 120, 150, 200, 250, 300, 400, 500, 600, <u>750</u>	300 & 750
1000	0.05, 0.1, 0.2, 0.5, 1	0.2, 0.5, 1	5, 10, 15, 20, 25, 30, 40, 50, 60, 75, 100, 120, 150, 200, 250, 300, 400, 500, 600, 750, <u>1000</u>	500 & 1000
1200	0.1, 0.2, 0.5, 1	0.5, 1	5, 10, 15, 20, 25, 30, 40, 50, 60, 75, 100, 120, 150, 200, 250, 300, 400, 500, 600, 750, 1000, <u>1200</u>	600 & 1200
1500	0.1, 0.2, 0.5, 1	0.5, 1	5, 10, 15, 20, 25, 30, 40, 50, 60, 75, 100, 120, 150, 200, 250, 300, 400, 500, 600, 750, 1000, 1200, <u>1500</u>	750 & 1500
2000	0.1, 0.2, 0.5, 1, 2	0.5, 1, 2	5, 10, 15, 20, 25, 30, 40, 50, 60, 75, 100, 120, 150, 200, 250, 300, 400, 500, 600, 750, 1000, 1200, 1500, <u>2000</u>	1000 & 2000
2500	0.2, 0.5, 1, 2	0.5, 1, 2	5, 10, 15, 20, 25, 30, 40, 50, 60, 75, 100, 120, 150, 200, 250, 300, 400, 500, 600, 750, 1000, 1200, 1500, 2000, <u>2500</u>	1200 & 2500
3000	0.2, 0.5, 1, 2	1, 2	5, 10, 15, 20, 25, 30, 40, 50, 60, 75, 100, 120, 150, 200, 250, 300, 400, 500, 600, 750, 1000, 1200, 1500, 2000, 2500, <u>3000</u>	1500 & 3000
5000	0.5, 1, 2, 5	1, 2, 5	5, 10, 15, 20, 25, 30, 40, 50, 60, 75, 100, 120, 150, 200, 250, 300, 400, 500, 600, 750, 1000, 1200, 1500, 2000, 2500, 3000, <u>5000</u>	2500 & 5000
7500	0.5, 1, 2, 5	2, 5	5, 10, 15, 20, 25, 30, 40, 50, 60, 75, 100, 120, 150, 200, 250, 300, 400, 500, 600, 750, 1000, 1200, 1500, 2000, 2500, 3000, 5000, <u>7500</u>	3000 & 7500
10000	0.5, 1, 2, 5, 10	2, 5, 10	5, 10, 15, 20, 25, 30, 40, 50, 60, 75, 100, 120, 150, 200, 250, 300, 400, 500, 600, 750, 1000, 1200, 1500, 2000, 2500, 3000, 5000, 7500, <u>10000</u>	5000 & 10000
20000	1, 2, 5, 10, 20	5, 10, 20	5, 10, 15, 20, 25, 30, 40, 50, 60, 75, 100, 120, 150, 200, 250, 300, 400, 500, 600, 750, 1000, 1200, 1500, 2000, 2500, 3000, 5000, 7500, 10000, <u>20000</u>	10000 & 20000

2.6.4 Setup Menu

The CD-11 Indicator SEtUP Menu *must be entered the first time* the Indicator is used to set the scale base parameters to match the Indicator. **Do not attempt to calibrate the Indicator** before initially setting up the SEtUP Menu. All other menus should be entered and set up the first time the Indicator is used.

Procedure

With the Indicator ON, press and hold the **G/N/T/Menu** button until MENU is displayed. When the **G/N/T/Menu** button is released, CAL is displayed if the CAL jumper on the PC board is in place. When the CAL jumper is removed, the Indicator will not permit calibration. This jumper should be in place initially.

Press the **PRINT/Units** button, SEtUP is displayed.

Press the **G/N/T/Menu** button, LFTOFF is displayed. Legal for trade selections are:

'ON' - LFT (Legal for Trade) is ON

'OFF' - LFT is OFF.

'CAN' - LFT is set for Canada

Press the **PRINT/Units** button until desired LFT setting is reached.

Press **G/N/T/Menu** button, 0 2 is displayed. This is the Zero setting. Selections are:

2%: zero operating range is -2% to +2%.

18%: zero operating range is -2% to +18%.

100%: zero operating range is -2% to +100%.

NOTE: If LFT is ON, only 2% and 18% are available.

Press the **PRINT/Units** button until desired zero setting is reached.

Press the **G/N/T/Menu** button, CAL Un kg is displayed. This is the calibration unit setting. Selections are:

'lb' - calibration unit is lb

'kg' - calibration unit is kg.

Press the **PRINT/Units** button until desired calibration unit setting is reached.

2.6.4 Setup Menu (Cont.)

Procedure

Press the **G/NT/Menu** button, F xx is displayed. This is the full scale capacity setting. xx= value last set. Available selections are shown in the Setup Table in section 2.6.3.

A rectangular digital display showing the characters 'F' on the left and '5 kg' on the right.

Press the **PRINT/Units** button until desired capacity value is reached.

Press the **G/NT/Menu** button, gd0.001 is displayed. This is the graduation size setting. Available selections are shown in the Setup Table in section 2.6.3.

A rectangular digital display showing the characters 'gd0.001' followed by 'kg' on the right.

Press the **PRINT/Units** button until desired graduation value is reached.

Press the **G/NT/Menu** button, CP 5 kg is displayed. This is the full scale calibration point setting. The range is from 5kg/lb to 100% Full scale capacity.

A rectangular digital display showing the characters 'CP' on the left and '5 kg' on the right.

Press the **PRINT/Units** button until desired calibration value is reached.

Press the **G/NT/Menu** button to end this block, SAVE is displayed.

A rectangular digital display showing the characters 'SAVE' in a large, spaced-out font.

Press the **G/NT/Menu** button to save the menu setup setting. The next menu rEAD is displayed. The Indicator is now matched up with the scale base and the Indicator parameters may now be set and calibrated.

A rectangular digital display showing the characters 'rEAd' in a large, spaced-out font.

or

Press the **PRINT/Units** button to return to the SEtuP menu without saving changes.

A rectangular digital display showing the characters 'SEt uP' in a large, spaced-out font.

2.6.5 Readout Menu

The Readout menu is used to adapt the Indicator to environmental conditions and set various features that include: averaging level, stability level, measuring units, parts counting, display hold, auto zero tracking, timer, retain zero data, backlight and a factory service mode. Review all of the settings available before proceeding.

Procedure

To select any of the items in the Readout menu, proceed as follows:

NOTE: If entering from the preceding menu, disregard the first step.

With the Indicator ON, press and hold the **G/N/T/Menu** button until MENU is displayed. When the **G/N/T/Menu** button is released, CAL is displayed, then press the **PRINT/Units** button until rEAd is displayed.

Press the **G/N/T/Menu** button, rESEtn is displayed. This allows resetting the rEAd menu to factory defaults.

rESEtn = no, does not reset settings.

rESEty= yes, will reset the entire readout menu to factory defaults as follows:

AL Lo, StAb 1, UnOff g, Un On kg, Un On Lb, Un Off oz, Alt Off, AZt 0.5, AOt Off, rZd Off, bLAuto and EP OFF (service mode).

Press the **PRINT/Units** button for selections N or Y.

AVERAGING LEVEL

Press the **G/N/T/Menu** button, AL LO is displayed. This is the averaging level settings. Selections are:

'Lo' - Less processing, less stability and faster stabilization time.

'Hi' - More processing, greater stability and slower stabilization time.

(This is the default setting)

Averaging level compensates for vibration or excessive air currents on the scale base. During operation, the Indicator continually takes weight readings from the load cell. Successive readings are then digitally processed to achieve a stabilized display. Using this feature specifies how much processing is needed.

Press the **PRINT/Units** button until desired averaging level setting is reached.

2.6.5 Readout Menu (Cont.)

STABILITY

Press the **G/NT/Menu** button, StAb1 is displayed. This is the stability setting. Selections are:

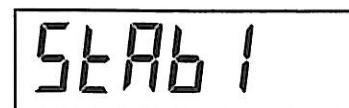

0.5d Smallest range: stability indicator is ON only when displayed weight is within .5 division.

1d Normal stability (this is the default setting). Fixed for LFT.

3d Higher stability, less sensitive.

The stability range specifies the weighing results and must be within a preset tolerance limit for a certain time to turn the stability indicator ON. When a displayed weight changes beyond the allowable range, the stability indicator turns OFF, indicating an unstable condition.

Press the **PRINT/Units** button until desired stability setting is reached.

UNITS SELECTION

Press the **G/NT/Menu** button, Un OFF g is displayed. This is the unit gram setting.

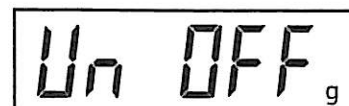

NOTE: g unit is not available for full scale capacities 100kg and above.

Press the **PRINT/Units** button for selections ON or OFF. OFF is the default setting.

Press the **G/NT/Menu** button, Un ON lb is displayed. This is the unit pound setting. This will be displayed when CAL UNIT kg was selected. When lb was selected as calibration unit, kg will display.

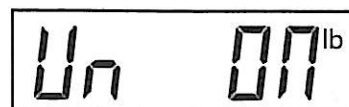

Press the **PRINT/Units** button for selections ON or OFF. ON is the default setting.

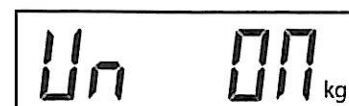

Press the **G/NT/Menu** button, Un OFF oz is displayed. This is the unit ounce setting.

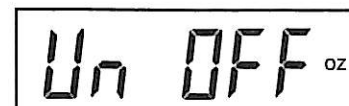

Press the **PRINT/Units** button for selections ON or OFF. OFF is the default setting.

2.6.5 Readout Menu (Cont.)

ALTERNATE MODE - not available with LFT ON or CAN

Press the **G/NT/Menu** button, ALtOFF is displayed. This is the alternate mode setting.

Selections are: OFF Standard weighing (this is the default setting)
 PC Parts Counting
 DH Display Hold - Man (manual)
 Semi (semi-automatic)
 Auto (automatic)

Press the **PRINT/Units** button until desired alternate mode setting is reached.

Alternate Mode enables either simple parts counting or display hold functions. When ALtdH (display hold) is selected, a choice of manual, semi-automatic or automatic settings are available. The alternate mode can be turned off so that neither mode is available. It is not possible to have both modes activated at the same time. For a complete description of alternate modes, refer to Section 4 Operation.

AUTO ZERO

Press the **G/NT/Menu** button, AZt 0.5 is displayed. This is the Auto Zero Threshold setting. Selections are:

0.5d Sets threshold to 0.5 divisions. (this is the default setting)
 1d Sets threshold to 1 division.
 3d Sets threshold to 3 divisions.

Auto Zero minimizes the effects of temperature changes and small disturbances on the zero reading. The Indicator maintains the zero display until the threshold is exceeded.

Press the **PRINT/Units** button until desired auto zero threshold setting is reached.

AUTO OFF TIMER

Press the **G/NT/Menu** button, AOtOFF is displayed. This is the Auto Off Timer setting. When set ON, the Indicator will shut off automatically after 5 minutes has elapsed on the condition that no button is pressed and the scale base platform is stable during that period.

Press the **PRINT/Units** button for selections ON or OFF. OFF is the default setting.

2.6.5 Readout Menu (Cont.)

RETAIN ZERO DATA

Press the **G/NT/MENU** button, Un rZdOFF is displayed. This is the Retain Zero Data setting. When set On, the Indicator stores the current zero point and restores it on the power-up.

Press the **PRINT/Units** button for selections ON or OFF. OFF is the default setting.

LCD BACK LIGHT

Press the **G/NT/MENU** button, bLAuTO is displayed. This is the LCD backlight setting. Selections are:

Auto Turns off the backlight in 5 seconds (this is the default setting)

ON Backlight is on continuously

OFF Backlight does not turn on

Press the **PRINT/Units** button until desired LCD backlight setting is reached.

EP

This is a service function and is not a user-operated feature. OFF is the default setting.

Not available with LFT ON or CAN.

SAVE

Press the **G/NT/MENU** button to end this block, SAVE is displayed.

Press the **G/NT/MENU** button to save the readout menu settings. The next menu Print is displayed.

or

Press the **PRINT/Units** button to go back to the SEtuP menu without saving changes.

NOTE: If initial setup, go to the next paragraph. To exit from the SEtuP menu, press the **PRINT/Units** button to skip to PRINT then to LOCKSW, then Quit. Press the **G/NT/MENU** button to go back to the weighing mode.

2.6.6 Print Menu

The Print menu provides data communication settings. It contains 9 submenus: Reset, Baud rate, Parity, Data Length, Stop Bits, Auto Print, Interval, Stable and Save.

Procedure

To select any of the items in the Print menu, proceed as follows:

NOTE: If entering from the preceding menu, disregard the first step.

With the Indicator ON, press and hold the **G/N/T/Menu** button until MENU is displayed. When the **G/N/T/Menu** button is released, CAL is displayed, then press the **PRINT/Units** button until Print is displayed.





Press the **G/N/T/Menu** button, rESEtN is displayed. This allows resetting the Print menu to factory defaults. rESEtN = no, does not reset settings. rESEtY=yes, will reset the entire Print menu to factory defaults as follows:
 Baud rate =2400, parity =none, data length=7, stop bit=2, Auto Print=AP OFF, if interval is selected=.0001, Stable Print= StbOFF.



Press the **PRINT/Units** button for selections N or Y.

Press the **G/N/T/Menu** button, bd2400 displayed. This is the baud rate setting. Selections are: 1200, 2400, 4800, 9600 and 19,200. 2400 is the default setting.



Press the **PRINT/Units** button until the desired baud rate is reached.

Press the **G/N/T/Menu** button, PAr nO is displayed. This is the parity bit setting. Selections are:

- PAr nO=none (this is the default setting)
- PAr Odd=odd
- PAr E=even



Press the **PRINT/Units** button until desired parity bit setting is reached.

Press the **G/N/T/Menu** button, dAtA 7 is displayed. This is the data length setting.



Press the **PRINT/Units** button for selections dAtA 7 or dAtA 8. Default setting is dAtA 7.

2.6.6 Print Menu (Cont.)

Press the **G/NT/Menu** button, StOP 2 is displayed. This is the stop bit setting.

Press the **PRINT/Units** button for selections StOP 1 or StOP 2. Default setting is StOP 2.

AUTO PRINT

Press the **G/NT/Menu** button, AP OFF is displayed.

This is the Auto print setting which enables data to a printer or PC to be printed automatically. Selection are:

- OFF (this is the default setting)
- Cont Prints data continuously
- Int Prints data on user selected intervals
- Stbl Print first stable non-zero value after each change in weighing value.

Press the **PRINT/Units** button until desired auto print setting is reached.

INTERVAL PRINTING

When interval has been selected in the previous step, an interval from 1 to 3600 seconds can be set. If Interval was not selected, this submenu does not appear.

Press the **G/NT/Menu** button, int is displayed. After a few seconds, a second display appears which allows the interval time in seconds to be set.

Pressing the **PRINT/Units** button advances the zero from left to right. Pressing the **TARE** button increments the active digit from 0 to 9.

Sample at right indicates 10 seconds.

NOTE: 0000 not valid.

2.6.6 Print Menu (Cont.)

STABLE

Press the **G/NT/Menu** button, Stb OFF is displayed.

When set to Stb ON, allows only stable weight values to be printed. When set Stb OFF, prints immediate value with stability indication. In LFT, fixed to Stb ON.

Press the **PRINT/Units** button for selections Stb ON or Stb OFF. Default setting is OFF.

SAVE

Press the **G/NT/Menu** button to end this block, SAVE is displayed.

Press the **G/NT/Menu** button to save the Print menu settings. The next menu LOCSW is displayed.

or

Press the **PRINT/Units** button to go back to the rEAd menu without saving.

NOTE: If initial setup, go to the next paragraph. To exit from the SEtUP, press the **PRINT/Units** button to skip to LOCKSW, then Quit. Press the **G/NT/Menu** button to go back to the weighing mode.

2.6.7 Lockout Menu

The Lockout menu (LOCSW) allows the user to lock and unlock the settings in the CAL, SEtUP, rEAd, and Print menus to prevent tampering or accidental changes. When used in conjunction with the Lock Switch (jumper) on the printed circuit board, the CAL, SEtUP, rEAd and Print menus can be read only and not changed.

Procedure

To select any of the items in the LOCSW menu, proceed as follows:

NOTE: If entering from the preceding menu, disregard the first step.

With the Indicator ON, press and hold the **G/NT/Menu** button until MEnU is displayed. When the **G/NT/Menu** button is released, CAL is displayed, then press the **PRINT/Units** button until LOCSW is displayed.

2.6.7 Lockout Menu (Cont.)

Press the **G/NT/Menu** button, LStOFF is displayed. This permits locking the SEtuP menu. LStOFF is unlocked, LSt On is read only (locked). This menu is hidden if the CAL jumper is off.

Press the **PRINT/Units** button for selections LSt ON or LStOFF.

Press the **G/NT/Menu** button, LrdOFF displayed. This permits locking the rEAd menu. LrdOFF is unlocked, Lrd On is read only (locked).

Press the **PRINT/Units** button for selections Lrd On or LrdOFF.

Press the **G/NT/Menu** button, LPtOFF is displayed. This permits locking the Print menu. LPtOFF is unlocked, LPtOn is read only (locked).

Press the **PRINT/Units** button for selections LPtOn or LPtOFF.

Press the **G/NT/Menu** button, LCLOFF is displayed. This permits locking the Calibration menu. LCLOFF is unlocked, LCL On is read only (locked). This menu is hidden if the CAL jumper is off.

Press the **PRINT/Units** button for selections LCL On or LCLOFF.

Press the **G/NT/Menu** button to end this block, SAVE is displayed.

Press the **G/NT/Menu** button to save the lockout menu settings. The next menu Quit is displayed.

or

Press the **PRINT/Units** button to go back to the lockout menu without saving.

After saving the lockout menu settings, press the **PRINT/Units** button to go to CAL or press the **G/NT/Menu** button to return to a weighing mode.

NOTE: At this point, the Indicator must be calibrated and the jumper removed from the CAL connector in order to lock the menus. The top cover of the Indicator should be free to gain access to the CAL jumper.

3. CALIBRATION AND SEALING

Model CD-11 Indicator requires span calibration before using. Span calibration ensures that the Indicator reads correctly within specifications. For best results, calibrate at or near full capacity. Calibration unit can be set to either kg or lb.

NOTE: When the Indicator is used in Legal for Trade or legally controlled applications, the calibration menu is locked out and is not accessible. This is to prevent unauthorized personnel from changing calibration.

Before beginning calibration, make sure masses are available. If you begin calibration and realize calibration masses are not available, exit the menu. The Indicator will retain previously stored calibration data. Calibration should be performed as necessary to ensure accurate weighing. Masses required to perform the procedures should be in compliance with the requirements of the scale base being used with the Indicator.

You have a choice of either span or linearity calibration. Span calibration checks zero and full span calibration points. Linearity calibration checks zero, mid span and full span points.

Procedure

SPAN CALIBRATION

With the Indicator ON, press and hold the **G/NT/Menu** button until MEnU is displayed. When the **G/NT/Menu** button is released, CAL is displayed.

Press the **G/NT/Menu** button, SPAN Y is displayed.

Press the **G/NT/Menu** button, -C- is displayed. The scale base **MUST** be stable during this period as it establishes a zero point. After a few seconds, the requested weight value is displayed. The sample illustration indicates a 5kg weight value (Cal Point CP was set for 5kg).

Place the indicated mass on the platform. Keep the platform stable during this period.

Press the **G/NT/Menu** button, -C- is displayed while the Indicator stores the reading and then displays the weight of the mass.

If the calibration was successful, the calibration weight is displayed and the calibration data is saved automatically. If unsuccessful, refer to the troubleshooting section.

Remove calibration masses from the platform.

NOTE: If the Indicator is to be used for legal for trade or legally controlled applications, it must be calibrated and the jumper removed from the CAL connector in order to lock the menus. The top cover of the Indicator should be free to gain access to the CAL jumper. Refer to section 3.1 for sealing for legal for trade use.

Procedure**LINEARITY CALIBRATION**

With the Indicator ON, press and hold the button **G/N/T/Menu** until MEnU is displayed. When the **G/N/T/Menu** button is released, CAL is displayed.

Press the **G/N/T/Menu** button, SPAN Y is displayed.

Press the **PRINT/Units** button, Lin Y is displayed.

Press the **G/N/T/Menu** button, -C- is displayed. The scale base **MUST** be stable during this period as it establishes a zero point. After a few seconds, the display flashes LIN CP twice and the requested weight value is displayed. The sample illustration indicates a 2kg center point for a 5kg scale.

Place the indicated mass on the platform. Keep the platform stable during this period.

Press the **G/N/T/Menu** button, -C- is displayed. The scale base **MUST** be stable during this period as it establishes a center point. After a few seconds, the display flashes FULLCP twice and the requested weight value is displayed.

Place the indicated mass on the platform and press the **G/N/T/Menu** button -C- is displayed.

If linearity calibration was successful, the calibration weight is displayed and the calibration data is saved automatically. If unsuccessful, refer to the troubleshooting section.

Remove calibration masses from platform.

NOTE: If the Indicator is to be used for legal for trade or legally controlled applications, it must be calibrated and the jumper removed from the CAL connector in order to lock out the menus. The top cover of the Indicator should be free to gain access to the CAL jumper. Refer to section 3.1 for sealing for legal for trade use.

GEOGRAPHICAL FACTOR (For Europe Only)

Press the **G/N/T/Menu** button, gEO 19 is displayed. This is the current geographical adjustment value.

A rectangular digital display showing the text "gEO 19" in a seven-segment font.

The geo factor includes settings from 0 to 31 and is used to compensate for varying gravity at different geographical areas (complete geographical adjustment settings are listed in the following table).

NOTE:

Only an authorized manufacturer's representative or certified verification personnel may make these changes.

Changing the geographical setting alters the calibration values.

Press the **Print/Units** button until the desired geographical adjustment value is reached. The factory default setting is gEO 19

SAVE

Press the **G/N/T/Menu** button to end this block, SAVE is displayed.

A rectangular digital display showing the text "SAVE" in a seven-segment font.

Press the **G/N/T/Menu** button to save the geographical factor setting. The next menu SEt uP is displayed.

A rectangular digital display showing the text "SEt uP" in a seven-segment font.

or

Press the **Print/Units** button to go back to the CAL menu without saving changes to the geographical setting.

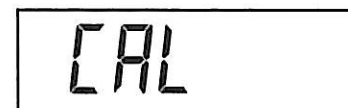
A rectangular digital display showing the text "CAL" in a seven-segment font.**QUIT**

To exit from the CAL menu, press the **Print/Units** button to advance to Quit. Then press the **G/N/T/Menu** button to go back to the weighing mode.

A rectangular digital display showing the text "Quit" in a seven-segment font.

GEOGRAPHICAL FACTOR (cont.)

GEOGRAPHICAL ADJUSTMENT VALUES

Geographical latitude in the northern or southern hemisphere in degrees and minutes	Elevation above sea level in meters										
	0	325	650	975	1300	1625	1950	2275	2600	2925	3250
	325	650	975	1300	1625	1950	2275	2600	2925	3250	3575
	Elevation above sea level in feet										
	0	1060	2130	3200	4260	5330	6400	7460	8530	9600	10660
	1060	2130	3200	4260	5330	6400	7460	8530	9600	10660	11730
0°0'-5°46'	5	4	4	3	3	2	2	1	1	0	0
5°46'-9°52'	5	5	4	4	3	3	2	2	1	1	0
9°52'-12°44'	6	5	5	4	4	3	3	2	2	1	1
12°44'-15°6'	6	6	5	5	4	4	3	3	2	2	1
15°6'-17°10'	7	6	6	5	5	4	4	3	3	2	2
17°10'-19°2'	7	7	6	6	5	5	4	4	3	3	2
19°2'-20°45'	8	7	7	6	6	5	5	4	4	3	3
20°45'-22°22'	8	8	7	7	6	6	5	5	4	4	3
22°22'-23°54'	9	8	8	7	7	6	6	5	5	4	4
23°54'-25°21'	9	9	8	8	7	7	6	6	5	5	4
25°21'-26°45'	10	9	9	8	8	7	7	6	6	5	5
26°45'-28°6'	10	10	9	9	8	8	7	7	6	6	5
28°6'-29°25'	11	10	10	9	9	8	8	7	7	6	6
29°25'-30°41'	11	11	10	10	9	9	8	8	7	7	6
30°41'-31°56'	12	11	11	10	10	9	9	8	8	7	7
31°56'-33°9'	12	12	11	11	10	10	9	9	8	8	7
33°9'-34°21'	13	12	12	11	11	10	10	9	9	8	8
34°21'-35°31'	13	13	12	12	11	11	10	10	9	9	8
35°31'-36°41'	14	13	13	12	12	11	11	10	10	9	9
36°41'-37°50'	14	14	13	13	12	12	11	11	10	10	9
37°50'-38°58'	15	14	14	13	13	12	12	11	11	10	10
38°58'-40°5'	15	15	14	14	13	13	12	12	11	11	10
40°5'-41°12'	16	15	15	14	14	13	13	12	12	11	11
41°12'-42°19'	16	16	15	15	14	14	13	13	12	12	11
42°19'-43°26'	17	16	16	15	15	14	14	13	13	12	12
43°26'-44°32'	17	17	16	16	15	15	14	14	13	13	12
44°32'-45°38'	18	17	17	16	16	15	15	14	14	13	13
45°38'-46°45'	18	18	17	17	16	16	15	15	14	14	13
46°45'-47°51'	19	18	18	17	17	16	16	15	15	14	14
47°51'-48°58'	19	19	18	18	17	17	16	16	15	15	14
48°58'-50°6'	20	19	19	18	18	17	17	16	16	15	15
50°6'-51°13'	20	20	19	19	18	18	17	17	16	16	15
51°13'-52°22'	21	20	20	19	19	18	18	17	17	16	16
52°22'-53°31'	21	21	20	20	19	19	18	18	17	17	16
53°31'-54°41'	22	21	21	20	20	19	19	18	18	17	17
54°41'-55°52'	22	22	21	21	20	20	19	19	18	18	17
55°52'-57°4'	23	22	22	21	21	20	20	19	19	18	18
57°4'-58°17'	23	23	22	22	21	21	20	20	19	19	18
58°17'-59°32'	24	23	23	22	22	21	21	20	20	19	19
59°32'-60°49'	24	24	23	23	22	22	21	21	20	20	19
60°49'-62°9'	25	24	24	23	23	22	22	21	21	20	20
62°9'-63°30'	25	25	24	24	23	23	22	22	21	21	20
63°30'-64°55'	26	25	25	24	24	23	23	22	22	21	21
64°55'-66°24'	26	26	25	25	24	24	23	23	22	22	21
66°24'-67°57'	27	26	26	25	25	24	24	23	23	22	22
67°57'-69°35'	27	27	26	26	25	25	24	24	23	23	22
69°35'-71°21'	28	27	27	26	26	25	25	24	24	23	23
71°21'-73°16'	28	28	27	27	26	26	25	25	24	24	23
73°16'-75°24'	29	28	28	27	27	26	26	25	25	24	24
75°24'-77°52'	29	29	28	28	27	27	26	26	25	25	24
77°52'-80°56'	30	29	29	28	28	27	27	26	26	25	25
80°56'-85°45'	30	30	29	29	28	28	27	27	26	26	25
85°45'-90°00'	31	30	30	29	29	28	28	27	27	26	26

3.1 Legal for Trade (LFT) Operation and Sealing

Before this product can be used in legal-for-trade or legally controlled applications, it must be inspected in accordance with local weights and measures or approval agency regulations. It is the responsibility of the purchaser to ensure that all pertinent legal requirements are met. Please contact your local weights and measures office or authorized manufacturer's representative for further details.

Legal for Trade (LFT) operation is possible through a software controlled LOCSW menu which can be set to lock out the CAL, SEtUP, rEAd, and Print menus by setting the lock settings to ON. When the menus have been locked and the Indicator has been calibrated, the Indicator can be used to operate in a legal for trade application after sealing. The software settings work in conjunction with a Lock Switch (CAL jumper) located on the PC board. The Indicator **MUST** be calibrated prior to performing this procedure.

Procedure

Perform the procedure in section 2.6.7 and set all menu items ON. This effectively locks all menus from being changed but can be viewed.

Remove the front cover from the Indicator to expose the PC board and tilt it back. Be careful as the cover is connected to the PC board by a flexible cable.

Refer to the illustrations on the right and note the position of the CAL jumper. The first illustration shows the jumper in place. To lock out the menus, remove the jumper and position it on one pin as shown in the second illustration. This removes the jumper and stores it in the event it has to be repositioned.

Replace the four cover screws and one sealing screw.

Replace the batteries and battery cover.

After the Indicator has been tested and found to comply with local applicable regulations by local approving personnel, it may be sealed as follows:

LEAD AND WIRE SEAL

Replace the pan head screw with the hex socket security screw and washer in the plastic bag containing the accessories. See illustration at right. Place wire seal through the hole as shown and compress lead seal in place.

PAPER SEAL

If an audit trail or paper seal will be used, install the pan head screw to the case and place seal over the screw area. The sealing area is located on the bottom of the case in a recessed area.

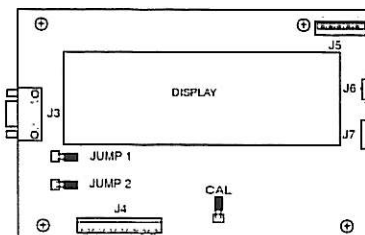

PC Board Connections.

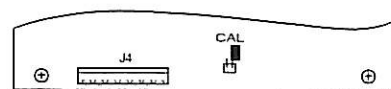

CAL Jumper Shown in Stored or ON Position.

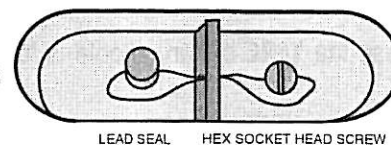

LEAD SEAL HEX SOCKET HEAD SCREW

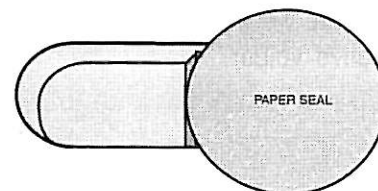

Sealing Methods

4. OPERATION

Before using the Indicator, make sure it has been properly set up and calibrated. Refer to Sections 2 and 3 and the Overview of Controls and Indicator Functions to review settings.

4.1 Turning On Indicator

Press the **ON ZERO/Off** button until the LCD display appears. The display momentarily displays segment check, the software version of the Indicator and then goes into a weighing mode. The weighing mode and decimal point position may be different depending on the setup of the Indicator.



4.2 Turning Off Indicator

To turn the Indicator off, press and hold the **ON ZERO/Off** button until OFF is displayed.

4.3 Zero Operation

Press the **ON ZERO/Off** button to zero the Indicator. The display acknowledges by indicating the selected measuring unit followed by a zeroed display.

NOTE: Stable cursor must be lit to accept zero operation.

Place item to be weighed on the scale platform. The display indicates a sample of 5kg, gross weight.

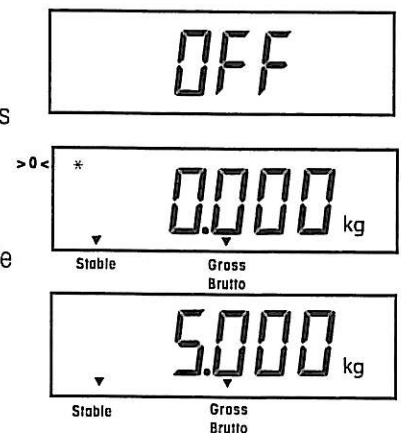

4.4 Tare Operation

When weighing material or objects that must be held in a container, taring stores the container weight in the Indicator's memory. To store the container weight, proceed as follows:

Place the container on the scale. Sample shown is 2kg.

Press the **TARE** button. Scale is tared and shows Net weight.

NOTE: Stable cursor must be lit to accept tare operation.

If the tare weight is removed from the scale, the Net weight is displayed as a negative value

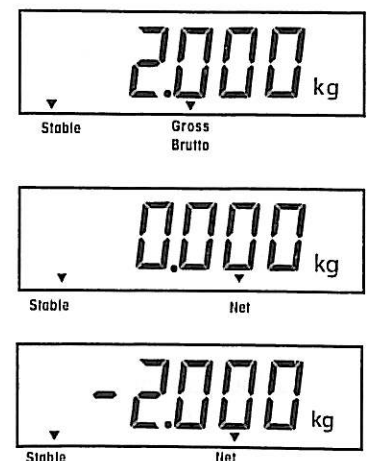

4.5 Gross/Net/Tare Recall Operation

When a container has been placed on the platform and tared, its weight is stored in memory. Adding material to the container is shown as NET weight. The gross weight is a combination of the tared weight and the material. The **G/N/T/Menu** button allows switching between GROSS, NET and TARE weights.

Repeatedly press the **G/N/T/Menu** button to cycle through Gross, Tare and Net readings. The sample illustrations indicate a tare weight of 2kg simulating a container, a net weight of 3kg which would be the material in the container and a gross weight of 5kg which is the total weight of the container and material. After a few seconds, the display will return to a NET weight.



4.6 Clear Tare Operation

To clear the tared weight stored in memory, proceed as follows:
With no load on the scale base, press the **TARE** button.

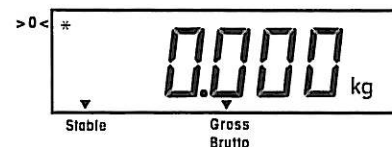

4.7 Unit Switch Operation

To switch measuring units, proceed as follows:
Press and hold **PRINT/Units** button until display changes to selected measuring unit. Depending on which units are enabled in the menu, you have a choice of g, lb, kg or oz. The display sample indicates 3kg load changed to lbs.

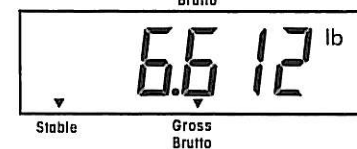

4.8 Parts Counting Operation

Parts counting is enabled only when selected in the rEAd menu (refer to section 2.6.5). In the parts counting mode, the Indicator displays the quantity of parts placed on the platform. The Indicator determines the quantity based on the average weight of a single part. All parts must be uniform in weight for accurate measurements.

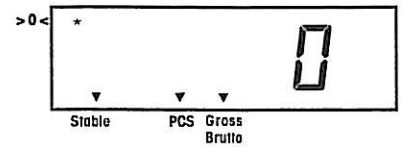

4.9 Establishing the Average Piece Weight (APW)

Press and hold the **PRINT/Units** button until the PCS cursor is displayed.

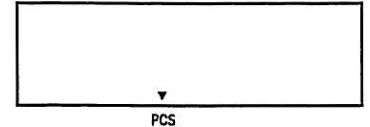

Press and hold the **G/NT/Menu** until SEtPCS is displayed. This is displayed for about 1 second, then SEt 5 is displayed.

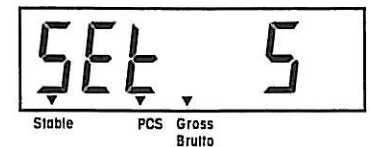

Select an alternate sample size by pressing and holding the **PRINT/Units** button. Choices are 5, 10, 20, and 50. Place count samples on platform.

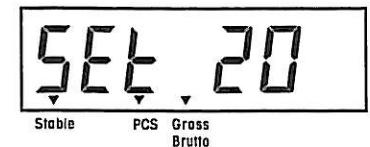
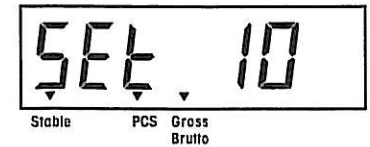

Press the **G/NT/Menu** button to accept current sample. The new APW is established. Place parts on platform or in a container to count. If a container is used, be sure to tare the empty container first.

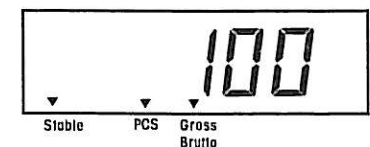

Additional samples may be added to the platform as long as the same sample weight initially entered is used with the samples being weighed.

4.10 Returning to a Weighing Mode

Press the **PRINT/Units** button until the display indicates the desired measuring unit either kg, lb, g or oz.



4.11 Returning to a Preset APW

If the APW has been calculated previously, the Indicator stores the value in memory. Proceed as follows to use a previously set APW:

Press and hold the **PRINT/Units** button until PCS cursor is displayed.

Place samples on the platform. The display indicates the number of pieces based on the previously entered data. Sample shown at right indicates 100 pieces.

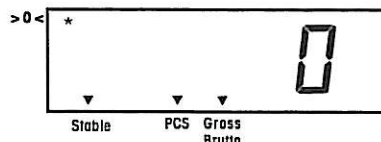

CAUTION

**WHEN POWER IS TURNED OFF, APW
WILL ALWAYS RETURN TO THE PREVIOUSLY STORED APW.**

4.12 Display Hold Modes

The Display Hold mode is enabled by entering the Alternate mode sub-menu in the rEAd menu. The Alternate mode selections are: ALtOFF, ALt PC, ALt dH. To enable the Display Hold mode, select ALt dH.

When ALt dH (display hold) is selected, the following choices are available: dHMAN (manual display hold), dHSEM (semi-automatic display hold), and dHAuto (automatic display hold). dHMan is the default setting. These choices are displayed only if ALt dH is selected.

The Display Hold mode allows the maximum stable weight value to be held on the display and sent to a peripheral device prior to being cleared.

The Display Hold types operate as described below:

4.12.1 Manual Display Hold (dHMAN)

To activate the Manual Display Hold mode, press and hold the **PRINT/Units** button until the LCD cursor lights above the Display Hold text on the panel. The cursor will blink to indicate that the scale is ready. Display shown at right indicates an empty platform.

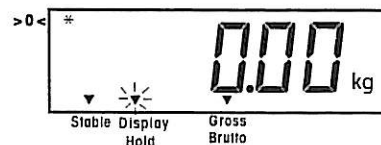

4.12.1 Manual Display Hold (dHMA) (Cont.)

When a load exceeding 5d (divisions) above zero is placed on the scale, the highest stable weight reading will be frozen on the display and the cursor will stop blinking. Example 5kg.

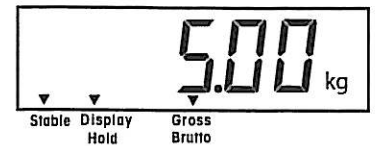

If an additional load exceeding 5d above the current Display Hold value is added to the scale (example 10kg), the value will be replaced by the new Display Hold value.



A short press of the **PRINT/Units** button sends the Display Hold value to the RS232, the display is unfrozen, the scale returns to the normal weighing mode and the Display Hold cursor turns off. The Display Hold value can also be cleared, without sending the value to the RS232, by turning the scale off.



4.12.2 Semi-automatic Display Hold (dHSEM)

When dHSEM is selected, the Semi-Automatic Display Hold mode becomes active immediately upon exiting the SEtUP menu. In this case, the display hold operation starts automatically and is cleared manually.

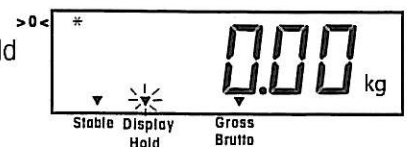

When a load exceeding 5d above zero is placed on the platform, the highest stable weight reading will be frozen on the display and the cursor will stop blinking. Example 5kg.

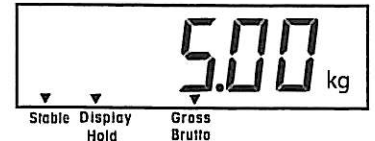

If an additional load exceeding 5d above the current Display Hold value is added to the scale (example 10kg), the value will be replaced by the new Display Hold value.



After the load is removed to within 5d of zero, a short press of the **PRINT/Units** button sends the Display Hold value to the RS232, the display is unfrozen, the scale returns to the ready mode and the Display Hold cursor resumes blinking. The Display Hold value can also be cleared, without sending the value to the RS232, by turning the scale off.

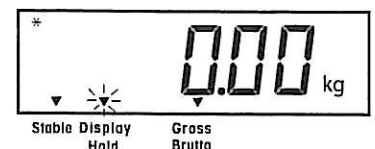

4.12.3 Automatic Display Hold (dHAuto)

When dHAuto is selected, the Automatic Display Hold mode becomes active immediately upon exiting the SetuP menu. In this case, the display hold operation is started and cleared automatically. When the load on the platform is within 5d of zero, the scale is in the ready mode with the Display Hold cursor blinking.

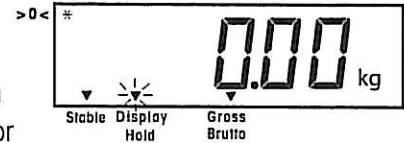

When a load exceeding 5d above zero is placed on the platform, the highest stable weight reading will be frozen on the display and the Display Hold cursor will stop blinking. Example 5kg.



If an additional weight exceeding 5d above the current Display Hold value is added to the scale (example 10kg), the value will be replaced by the new Display Hold value.

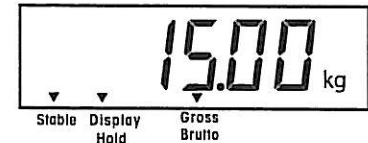

When the load is removed to within 5d of zero, the Display Hold value is sent to the RS232, the display is unfrozen, the scale returns to the ready mode and the Display Hold cursor resumes blinking. The Indicator retains the current weight display until a new load exceeding 5d of zero is placed on the platform. The Display Hold value can also be cleared, without sending the value to the RS232, by turning the scale off.



4.13 RS232 Commands

All communication is accomplished using standard ASCII format. Characters shown in the following table are acknowledged by the Indicator. Invalid command response "ES" error indicates the Indicator has not recognized the command. Commands sent to the Indicator must be terminated with a carriage return (CR) or carriage return-line feed (CRLF). Data output by the Indicator is always terminated with a carriage return - line feed (CRLF). See section 2.6.6 for RS232 and Print Setup.

Data output can be initiated in one of two ways:

1. By pressing the **PRINT/Units** button, or
2. Sending a print command ("P") from a computer.

Output Formats

The output format is as follows:

	Weight*	Spaces	Unit	Stable	Legend	CR	LF
Length:	9	1	3	1	1	1	1

blank=stable G,N,T
 "? "= not stable

- * Displayed weight sent right justified with lead zero blanking. Nine characters (fixed) include:
- decimal point (1)
 - weight (7 max)
 - polarity (1) : blank if positive
 - floating negative (1)

4.13 RS232 Commands (Cont.)

RS232 USER COMMAND TABLE

Command Character	Description
?	Print current mode: kg, g, lb, oz.
P	Same as pressing PRINT button.
T	Same as pressing TARE button.
Z	Same as pressing ZERO button.
xS	Print Stable only. Where x=0 Off, and x=1 On
AS	Automatically send data when stable after motion.
xxxxS	Send at interval. Where xxxx=1 to 3600 seconds.
CS	Send as fast as possible (continuous print)
M	Increment to next enabled unit

NOTE: To turn auto printing, interval printing or continuous printing off, send 1S or 0S to reset normal printing mode.

4.14 Printing Data

Printing data to an external computer or printer requires that the communication parameters in the Print menu be set first. Refer to paragraph 2.6.6 Print Menu for proper set up.

To print data, press the **PRINT/Units** button. The display acknowledges by momentarily blinking off.

NOTE: If the **PRINT/Units** button is held down too long, the display will advance to another measuring unit without sending the print data.

5 CARE AND MAINTENANCE

To keep the Indicator operating properly, the housing should be kept clean and free from foreign material. If necessary, a cloth dampened with a mild detergent may be used.

5.1 Troubleshooting

SYMPTOM	PROBABLE CAUSE(S)	REMEDY
Unit will not turn on.	<p>Adapter not plugged in or properly connected.</p> <p>Batteries dead or not properly installed.</p> <p>Membrane switch failure.</p>	<p>Check ac power.</p> <p>Check AC adapter connections.</p> <p>Make sure adapter connector is plugged securely on the Indicator.</p> <p>Check battery connector.</p> <p>Check orientation of the batteries.</p> <p>Replace batteries.</p> <p>Check functions of membrane switch.</p>
Cannot zero Indicator, or will not zero when turned on.	<p>Load on scale base exceeds allowable zero % entered in ZERO parameter of Setup menu.</p> <p>Retain Zero Data is enabled in scale menu.</p>	<p>Remove load on scale base to less than entered zero %.</p> <p>Change allowable zero % in ZERO parameter of Setup menu.</p> <p>Normal operation when this feature is disabled.</p>
Center of Zero display indicator erratic or does not appear with no load on scale base.	Scale base motion or disturbances exceed center of zero criteria.	<p>Remove disturbances or reduce motion.</p> <p>Increase AZT level in readout menu.</p> <p>Increase averaging level in readout menu.</p>

5 CARE AND MAINTENANCE (Cont.)

5.1 Troubleshooting (Cont.)

SYMPTOM	PROBABLE CAUSE(S)	REMEDY
Cannot display weight in desired weighing unit.	Desired unit not set to ON in Readout menu.	<p>Enable desired unit in Readout menu. See section 2.6.5</p> <p>Conversion too large (typically in g).</p>
RS232 not working.	<p>RS232 communication parameters set up incorrectly.</p> <p>Improper or loose cable connections.</p>	<p>Verify communication parameters.</p> <p>Check cable connections.</p>
Unable to calibrate unit.	<p>Scale base disconnected.</p> <p>SETUP Lockout switch set to ON and jump CAL on the circuit board set to open position.</p> <p>Incorrect value for calibration mass.</p>	<p>Check connections.</p> <p>Set LCL to OFF in the LocSW menu, and set Jump CAL on the circuit board to short position. Refer to sections 2.3 and 2.6.7.</p> <p>Use correct calibration mass.</p>

5.2 Error Codes List

The following list describes the various error codes and which can appear on the display and the suggested remedy.

LoBat	Indicates weak batteries. Approximately 20 minutes of operating time remain.
Error 1	Indicates an overload condition.
Error 2	Indicates an underload condition.
Error 7	EEPROM data incorrect.
Error 14	Zero exceeds <u>ZERO%</u> and cannot be zeroed.
Err 21	Calibration data does not match current full scale, Grad and Cal Point settings. Settings must be restored or the Indicator must be recalibrated using the current settings.

5.3 Service Information

If the Troubleshooting section does not resolve or describe your problem, you will need to contact an authorized Ohaus Service Agent. For Service assistance in the United States, please call Aftermarket, Ohaus Corporation toll-free at (800) 526-0659. An Ohaus Product Service Specialist will be available to help you.

5.4 Replacement parts

<u>Description</u>	<u>Ohaus Part No.</u>
AC Adapter North America, 100-132 V ac, 60 Hz	80500435
AC Adapter Continental Europe, 196-253 V ac, 50 Hz	80500436
AC Adapter UK, 196-264 V ac, 50 Hz	80500437

5.5 Accessories

<u>Description</u>	<u>Ohaus Part No.</u>
Adjustable Column	71135127
Wall Mounting Bracket	71152686
Scale Base Mounting Plate	80250686
RS232 Interface Cable/Printer SF42	80500537
RS232 Interface Cable/blunt end	80500430
RS232 Interface Cable/PC 25 Pin	80500431
RS232 Interface Cable/PC 9 Pin	80500433
Printer	SF42

5.6 Technical Data

Materials

Housing GEC6200 Cyclooy plastic.
Keypad/display overlay polyester

Ambient conditions

The technical data is valid under the following ambient conditions:

Ambient temperature	-10°C to 40°C/ 14°F to 104°F
Relative humidity	10%.....95%, noncondensing
Height above sea level	up to 4000m

5.6 Technical Data (Cont.)

Capacity (lb or kg)*	5 to 20,000
Graduation (readability) lb or kg*	0.001 to 20
Maximum Displayed Resolution	1: 20,000
LFT Resolution	1:5000
Weighing Units*	lb, kg, oz, g**
Functions*	Parts counting, Display hold
Over Range Capacity	Maximum Capacity +9d
Stabilization Time	< 3 seconds
Auto-Zero Tracking*	Off, 0.5, 1, or 3 divisions
Zeroing Range*	2%, 18%, or 100% of capacity
Span Calibration*	5kg/lb to 100% of scale base capacity
Weighing System	Analog strain gauge load cell
Load Cell Excitation Voltage	5V dc
Load Cell Input Sensitivity	Up to 3mV/V
Load Cell Drive	4 x 350 ohm load cells
Display	1 in./2.5 cm digit height 1.5 in./3.8 cm high x 4.9 in./12.5 cm wide backlit LCD
Power	AC 120 or 230 V ac and 240 Vac, 43-63 Hz or 6 alkaline C-type batteries
Typical Battery Life	up to 100 hours with one 350 ohm load cell
Operating Temperature	-10°C to 40°C (14°F to 104°F)
Keyboard	4 function membrane switches
Dimensions (WxDxH) (in/cm)	8.25 x 6.75 x 3/20.0 x 17.2 x 7.7
Shipping Packing Dimensions (in/cm)	13 x 9 x 5/32 x 22.5 x 12.5
Net Weight (lb/kg)	1.3/0.6
Shipping Weight (lb/kg)	3/1.5

* User selectable

** g unit not available for full scale capacities 100kg and above.

Legal for Trade/Type approvals: NTEP, Canada Weights and Measures, CE/OIML

LIMITED WARRANTY

Ohaus products are warranted against defects in materials and workmanship from the date of delivery through the duration of the warranty period. During the warranty period Ohaus will repair, or, at its option, replace any component(s) that proves to be defective at no charge, provided that the product is returned, freight prepaid, to Ohaus.

This warranty does not apply if the product has been damaged by accident or misuse, exposed to radioactive or corrosive materials, has foreign material penetrating to the inside of the product, or as a result of service or modification by other than Ohaus. In lieu of a properly returned warranty registration card, the warranty period shall begin on the date of shipment to the authorized dealer. No other express or implied warranty is given by Ohaus Corporation. Ohaus Corporation shall not be liable for any consequential damages.

As warranty legislation differs from state to state and country to country, please contact Ohaus or your local Ohaus dealer for further details.