

DATA SHEET

CBT3244

Octal bus switch with Quad Output
Enables

Preliminary specification

1998 Dec 08

Octal bus switch with Quad Output Enables

CBT3244

FEATURES

- Functionally equivalent to QS3244
- Standard '244-type pinout
- 5Ω switch connection between two ports
- TTL compatible control input levels
- Package options include plastic small outline (D), shrink small outline (DB), thin shrink small outline (TSSOP)

DESCRIPTION

The CBT3244 provides eight bits of high-speed TTL-compatible bus switching in a standard '244 device pinout. The low on-state resistance of the switch allows connections to be made with minimal propagation delay.

The CBT3244 device is organized as two 4-bit low-impedance switches with separate output-enable (\overline{OE}) inputs. When \overline{OE} is low, the switch is on and data can flow from port A to port B, or vice versa. When \overline{OE} is high, the switch is open and high-impedance state exists between the two ports.

The CBT3244 is characterized for operation from -40°C to 85°C .

QUICK REFERENCE DATA

SYMBOL	PARAMETER	CONDITIONS $T_{amb} = 25^{\circ}\text{C}; \text{GND} = 0\text{V}$	TYPICAL	UNIT
t_{PLH} t_{PHL}	Propagation delay An to Yn	$C_L = 50\text{pF}; V_{CC} = 5\text{V}$		ns
$C_{IO(OFF)}$	Pin capacitance (OFF state)	$V_O = 3\text{V}$ or 0V	6	pF
I_{CCZ}	Total supply current	Outputs disabled; $V_{CC} = 5.5\text{V}$		μA

ORDERING INFORMATION

PACKAGES	TEMPERATURE RANGE	OUTSIDE NORTH AMERICA	NORTH AMERICA	DWG NUMBER
20-Pin plastic SO	-40°C to 85°C	CBT3244 D	CBT3244 D	SOT163-1
20-Pin Plastic SSOP Type II	-40°C to 85°C	CBT3244 DB	CBT3244 DB	SOT339-1
20-Pin Plastic TSSOP Type I	-40°C to 85°C	CBT3244 PW	CBT3244PW DH	SOT360-1

PIN CONFIGURATION

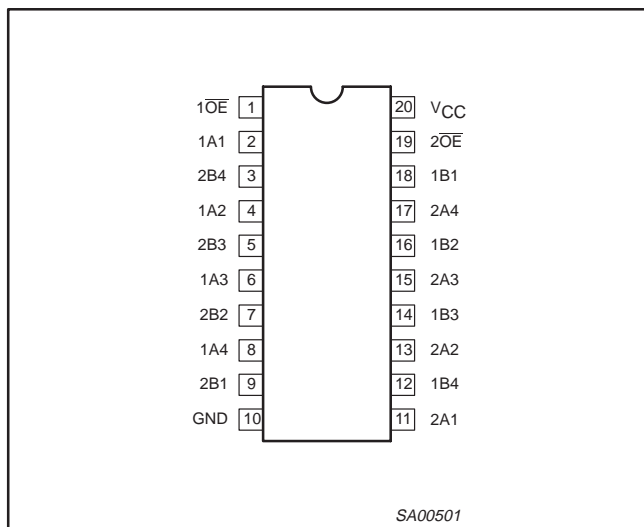

PIN DESCRIPTION

PIN NUMBER	SYMBOL	NAME AND FUNCTION
1, 19	$1\overline{OE}, 2\overline{OE}$	Output enable
2, 4, 6, 8	1A1–1A4	
11, 13, 15, 17	2A1–2A4	
18, 16, 14, 12	1B1–1B4	
9, 7, 5, 3	2B1–2B4	
10	GND	Ground (0V)
20	V_{CC}	Positive supply voltage

Octal bus switch with Quad Output Enables

CBT3244

LOGIC SYMBOL

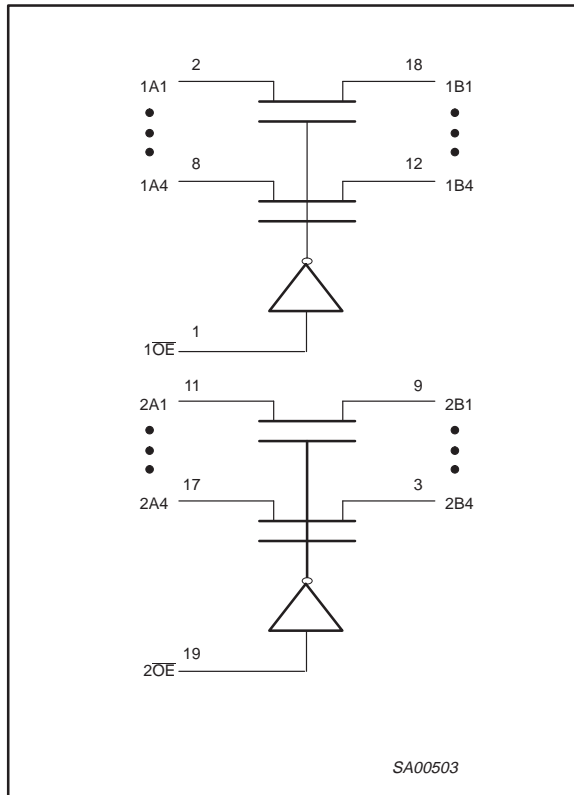

FUNCTION TABLE

INPUTS		OUTPUTS	
1OE	2OE	1A, 1B	2A, 2B
L	L	1A = 1B	2A = 2B
L	H	1A = 1B	Z
H	L	Z	2A = 2B
H	H	Z	Z

H = High voltage level
 L = Low voltage level
 Z = High impedance "off" state

ABSOLUTE MAXIMUM RATINGS^{1, 2}

SYMBOL	PARAMETER	CONDITIONS	RATING	UNIT
V _{CC}	DC supply voltage		-0.5 to +7.0	V
I _{IK}	DC input diode current	V _I < 0	-18	mA
V _I	DC input voltage ³		-1.2 to +7.0	V
I _{OK}	DC output diode current	V _O < 0	-50	mA
V _{OUT}	DC output voltage ³	output in Off or High state	-0.5 to +7	V
I _{OUT}	DC output current	output in Low state	128	mA
T _{stg}	Storage temperature range		-65 to 150	°C

NOTES:

- Stresses beyond those listed may cause permanent damage to the device. These are stress ratings only and functional operation of the device at these or any other conditions beyond those indicated under "recommended operating conditions" is not implied. Exposure to absolute-maximum-rated conditions for extended periods may affect device reliability.
- The performance capability of a high-performance integrated circuit in conjunction with its thermal environment can create junction temperatures which are detrimental to reliability. The maximum junction temperature of this integrated circuit should not exceed 150°C.
- The input and output voltage ratings may be exceeded if the input and output current ratings are observed.

Octal bus switch with Quad Output Enables

CBT3244

RECOMMENDED OPERATING CONDITIONS

SYMBOL	PARAMETER	LIMITS		UNIT
		Min	Max	
V_{CC}	DC supply voltage	4.5	5.5	V
V_{IH}	High-level input voltage	2.0		V
V_{IL}	Low-level Input voltage		0.8	V
T_{amb}	Operating free-air temperature range	-40	+85	°C

DC ELECTRICAL CHARACTERISTICS

SYMBOL	PARAMETER	TEST CONDITIONS	LIMITS			UNIT
			$T_{amb} = -40^{\circ}\text{C to } +85^{\circ}\text{C}$			
			Min	Typ ¹	Max	
V_{IK}	Input clamp voltage	$V_{CC} = 4.5\text{V}; I_I = -18\text{mA}$			-1.2	V
I_I	Input leakage current	$V_{CC} = 5.5\text{V}; V_I = \text{GND or } 5.5\text{V}$			± 5	μA
I_{CC}	Quiescent supply current ²	$V_{CC} = 5.5\text{V}; I_O = 0, V_I = V_{CC} \text{ or GND}$			50	μA
ΔI_{CC}	Additional supply current per input pin ²	$V_{CC} = 5.5\text{V}$, one input at 3.4V, other inputs at V_{CC} or GND			3.5	mA
C_I	Control pins	$V_I = 3\text{V or } 0, \overline{OE} = V_{CC}$		3		pF
$C_{IO(OFF)}$	Power-off leakage current	$V_O = 3\text{V or } 0$		6		pF
r_{on}^3	On-resistance	$V_{CC} = 4.5\text{V}; V_1 = 0\text{V}; I_1 = 64\text{mA}$		5	7	Ω
		$V_{CC} = 4.5\text{V}; V_1 = 0\text{V}; I_1 = 30\text{mA}$		5	7	
		$V_{CC} = 4.5\text{V}; V_1 = 0\text{V}; I_1 = 15\text{mA}$		10	15	

NOTES:

1. All typical values are at $V_{CC} = 5\text{V}$, $T_A = 25\text{C}$
2. This is the increase in supply current for each input that is at the specified TTL voltage level rather than V_{CC} or GND
3. Measured by the voltage drop between the A and the B terminals at the indicated current through the switch.
On-state resistance is determined by the lowest voltage of the two (A or B) terminals.

AC CHARACTERISTICS

GND = 0V; t_R ; $C_L = 50\text{pF}$

SYMBOL	PARAMETER	FROM (INPUT)	TO (OUTPUT)	74CBT3244		UNIT
				$T_{amb} = -40^{\circ}\text{C to } +85^{\circ}\text{C}$ $V_{CC} = +5.0\text{V} \pm 0.5\text{V}$		
				Min	Max	
t_{pd}	Propagation delay ¹	A or B	B or A		.25	ns
t_{en}	Output enable time to High and Low level	OE	A or B	1.0	8.9	ns
t_{dis}	Output disable time from High and Low level	OE	A or B	1.0	7.4	ns

NOTES:

1. This parameter is warranted but not production tested. The propagation delay is based on the RC time constant of the typical on-state resistance of the switch and a load capacitance of 50 pF, when driven by an ideal voltage source (zero output impedance).

Octal bus switch with Quad Output Enables

CBT3244

AC WAVEFORMS

$V_M = 1.5V, V_{IN} = GND \text{ to } 3.0V$

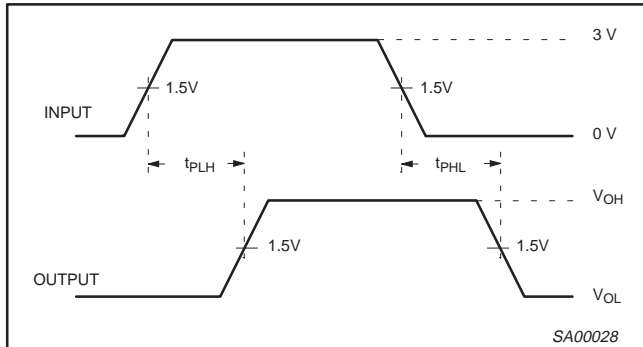

Waveform 1. Input to Output Propagation Delays

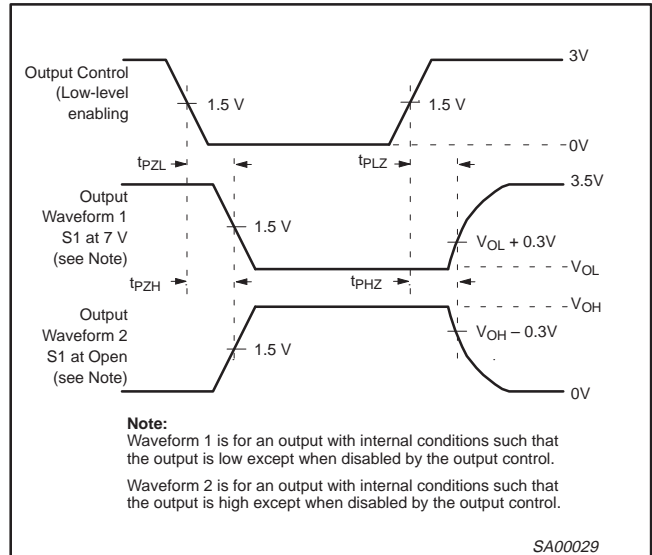

Note:
Waveform 1 is for an output with internal conditions such that the output is low except when disabled by the output control.
Waveform 2 is for an output with internal conditions such that the output is high except when disabled by the output control.

SA00029

Waveform 2. 3-State Output Enable and Disable Times

TEST CIRCUIT AND WAVEFORMS

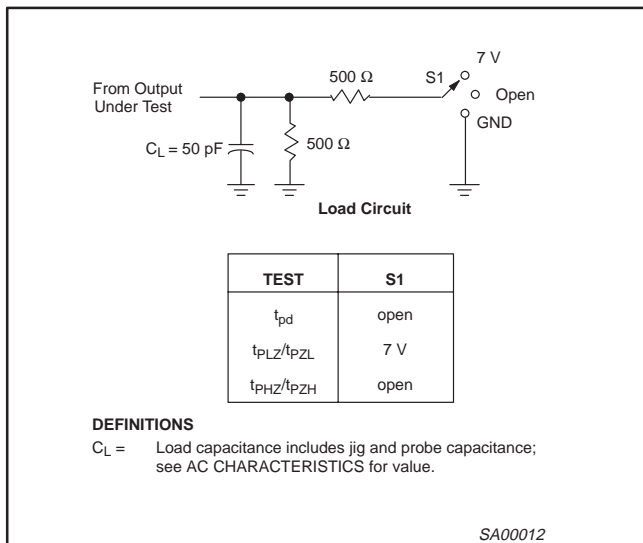

SA00012

NOTES:

1. All input pulses are supplied by generators having the following characteristics: $PRR \leq 10MHz, Z_O = 50 \Omega, t_r \leq 2.5 ns, t_f \leq 2.5 ns$.
2. The outputs are measured one at a time with one transition per measurement.

Octal bus switch with Quad Output Enables

CBT3244

SO20: plastic small outline package; 20 leads; body width 7.5 mm

SOT163-1

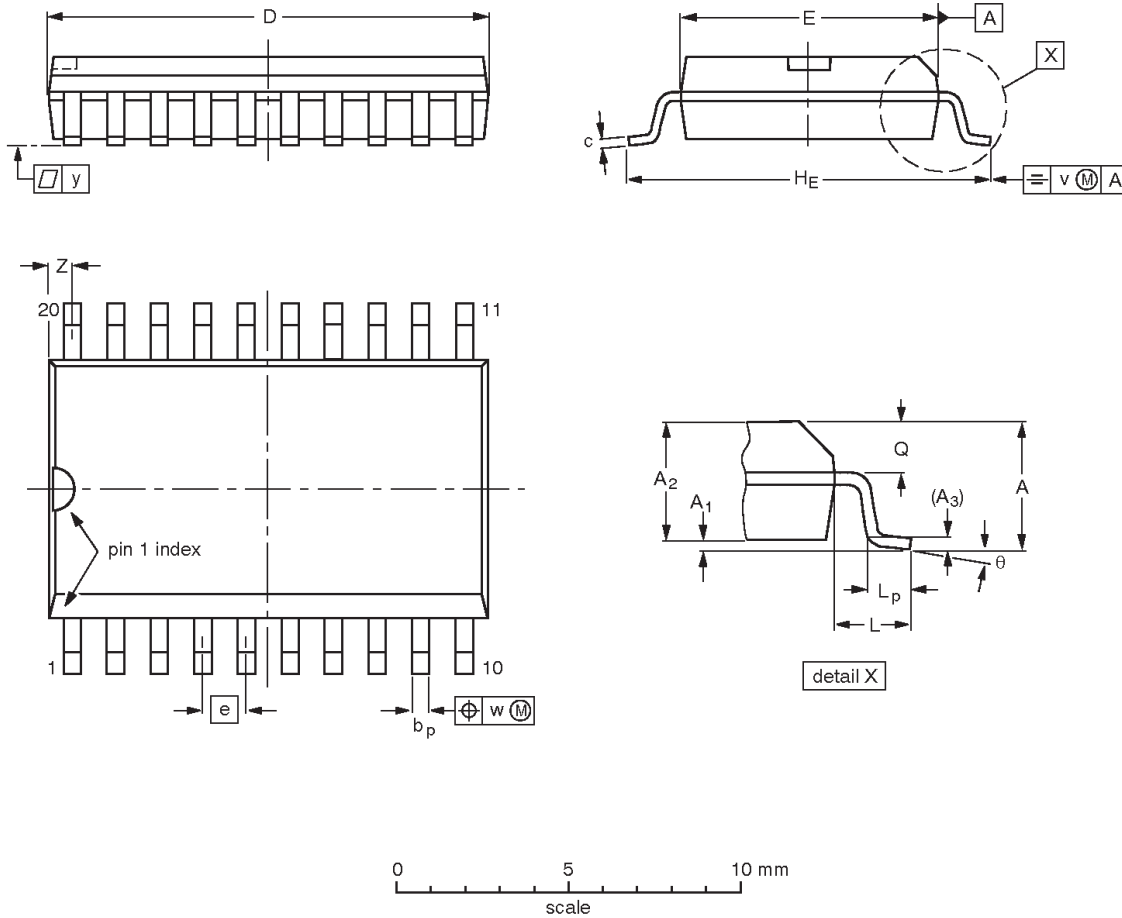

DIMENSIONS (inch dimensions are derived from the original mm dimensions)

UNIT	A max.	A ₁	A ₂	A ₃	b _p	c	D ⁽¹⁾	E ⁽¹⁾	e	H _E	L	L _p	Q	v	w	y	z ⁽¹⁾	θ
mm	2.65	0.30 0.10	2.45 2.25	0.25	0.49 0.36	0.32 0.23	13.0 12.6	7.6 7.4	1.27	10.65 10.00	1.4	1.1 0.4	1.1 1.0	0.25	0.25	0.1	0.9 0.4	8° 0°
inches	0.10	0.012 0.004	0.096 0.089	0.01	0.019 0.014	0.013 0.009	0.51 0.49	0.30 0.29	0.050	0.419 0.394	0.055	0.043 0.016	0.043 0.039	0.01	0.01	0.004	0.035 0.016	

Note

1. Plastic or metal protrusions of 0.15 mm maximum per side are not included.

OUTLINE VERSION	REFERENCES				EUROPEAN PROJECTION	ISSUE DATE
	IEC	JEDEC	EIAJ			
SOT163-1	075E04	MS-013AC				95-01-24 97-05-22

Octal bus switch with Quad Output Enables

CBT3244

SSOP20: plastic shrink small outline package; 20 leads; body width 5.3 mm

SOT339-1

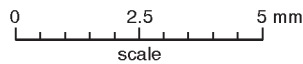
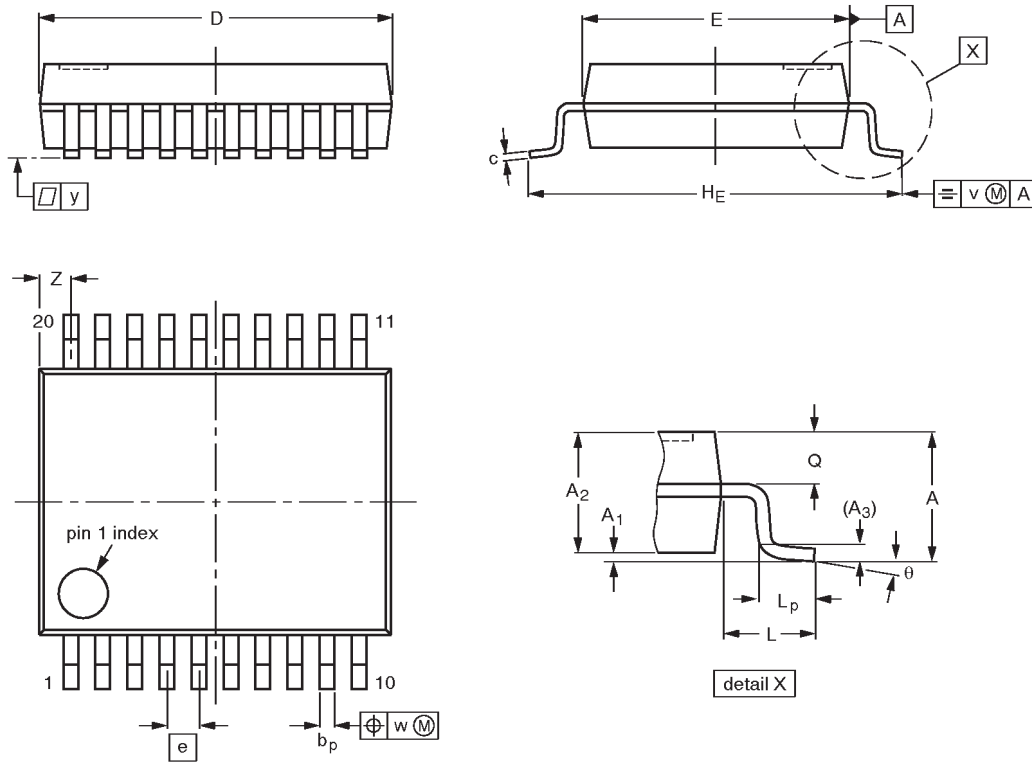

DIMENSIONS (mm are the original dimensions)

UNIT	A max.	A ₁	A ₂	A ₃	b _p	c	D ⁽¹⁾	E ⁽¹⁾	e	H _E	L	L _p	Q	v	w	y	Z ⁽¹⁾	θ
mm	2.0	0.21 0.05	1.80 1.65	0.25	0.38 0.25	0.20 0.09	7.4 7.0	5.4 5.2	0.65	7.9 7.6	1.25	1.03 0.63	0.9 0.7	0.2	0.13	0.1	0.9 0.5	8° 0°

Note

1. Plastic or metal protrusions of 0.20 mm maximum per side are not included.

OUTLINE VERSION	REFERENCES				EUROPEAN PROJECTION	ISSUE DATE
	IEC	JEDEC	EIAJ			
SOT339-1		MO-150AE				93-09-08 95-02-04

Octal bus switch with Quad Output Enables

CBT3244

TSSOP20: plastic thin shrink small outline package; 20 leads; body width 4.4 mm

SOT360-1

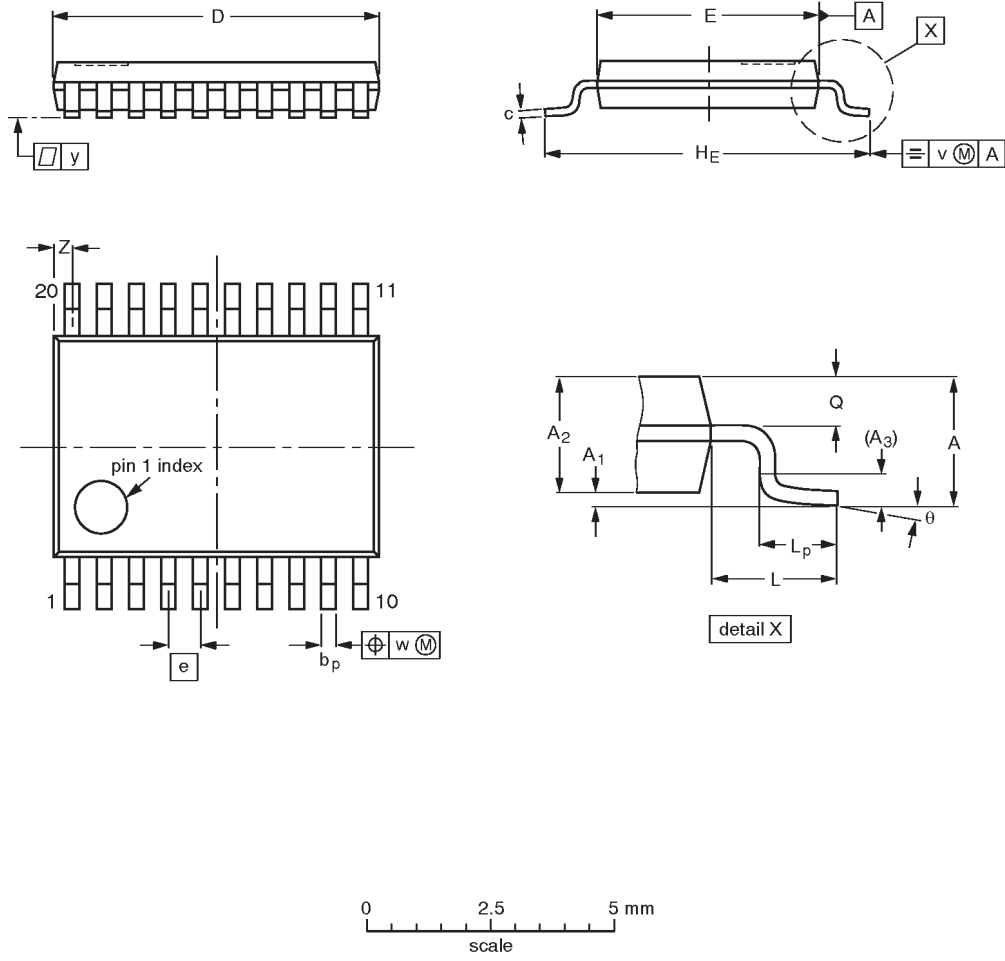

DIMENSIONS (mm are the original dimensions)

UNIT	A max.	A ₁	A ₂	A ₃	b _p	c	D ⁽¹⁾	E ⁽²⁾	e	H _E	L	L _p	Q	v	w	y	Z ⁽¹⁾	θ
mm	1.10	0.15 0.05	0.95 0.80	0.25	0.30 0.19	0.2 0.1	6.6 6.4	4.5 4.3	0.65	6.6 6.2	1.0	0.75 0.50	0.4 0.3	0.2	0.13	0.1	0.5 0.2	8° 0°

Notes

1. Plastic or metal protrusions of 0.15 mm maximum per side are not included.
2. Plastic interlead protrusions of 0.25 mm maximum per side are not included.

OUTLINE VERSION	REFERENCES				EUROPEAN PROJECTION	ISSUE DATE
	IEC	JEDEC	EIAJ			
SOT360-1		MO-153AC				-93-06-16- 95-02-04

Octal bus switch with Quad Output Enables

CBT3244

NOTES

Octal bus switch with Quad Output Enables

CBT3244

Data sheet status

Data sheet status	Product status	Definition [1]
Objective specification	Development	This data sheet contains the design target or goal specifications for product development. Specification may change in any manner without notice.
Preliminary specification	Qualification	This data sheet contains preliminary data, and supplementary data will be published at a later date. Philips Semiconductors reserves the right to make changes at any time without notice in order to improve design and supply the best possible product.
Product specification	Production	This data sheet contains final specifications. Philips Semiconductors reserves the right to make changes at any time without notice in order to improve design and supply the best possible product.

[1] Please consult the most recently issued datasheet before initiating or completing a design.

Definitions

Short-form specification — The data in a short-form specification is extracted from a full data sheet with the same type number and title. For detailed information see the relevant data sheet or data handbook.

Limiting values definition — Limiting values given are in accordance with the Absolute Maximum Rating System (IEC 134). Stress above one or more of the limiting values may cause permanent damage to the device. These are stress ratings only and operation of the device at these or at any other conditions above those given in the Characteristics sections of the specification is not implied. Exposure to limiting values for extended periods may affect device reliability.

Application information — Applications that are described herein for any of these products are for illustrative purposes only. Philips Semiconductors make no representation or warranty that such applications will be suitable for the specified use without further testing or modification.

Disclaimers

Life support — These products are not designed for use in life support appliances, devices or systems where malfunction of these products can reasonably be expected to result in personal injury. Philips Semiconductors customers using or selling these products for use in such applications do so at their own risk and agree to fully indemnify Philips Semiconductors for any damages resulting from such application.

Right to make changes — Philips Semiconductors reserves the right to make changes, without notice, in the products, including circuits, standard cells, and/or software, described or contained herein in order to improve design and/or performance. Philips Semiconductors assumes no responsibility or liability for the use of any of these products, conveys no license or title under any patent, copyright, or mask work right to these products, and makes no representations or warranties that these products are free from patent, copyright, or mask work right infringement, unless otherwise specified.

Philips Semiconductors
811 East Arques Avenue
P.O. Box 3409
Sunnyvale, California 94088-3409
Telephone 800-234-7381

© Copyright Philips Electronics North America Corporation 1998
All rights reserved. Printed in U.S.A.

print code

Date of release: 05-96

Document order number:

Let's make things better.