

FEATURES

- Individual select controls
- Extended 100E VEE range of -4.2V to -5.5V
- 550ps max. D to Output
- 800ps max. SEL to Output
- Internal 75KΩ input pull-down resistors
- Fully compatible with industry standard 10KH, 100K ECL levels
- Available in 28-pin PLCC package

DESCRIPTION

The SY10/100E157 contain four 2:1 multiplexers with differential outputs. The output data are controlled by the individual Select (SEL) inputs. The individual select control makes the devices well suited for random logic designs.

BLOCK DIAGRAM

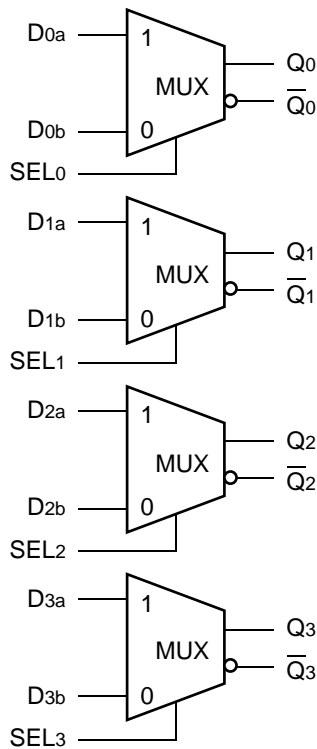

PIN CONFIGURATION

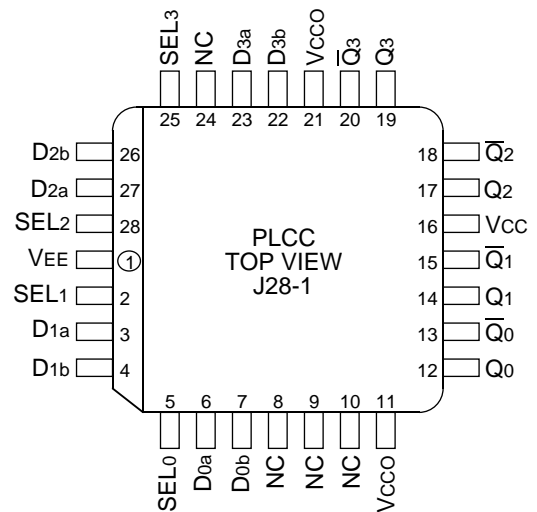

PIN NAMES

Pin	Function
D0a – D3a	Input Data a
D0b – D3b	Input Data b
SEL0 – SEL3	Select Inputs
Q0 – Q3	True Outputs
$\bar{Q}0 - \bar{Q}3$	Inverted Outputs
Vcco	Vcc to Output

TRUTH TABLE

SEL	Data
H	a
L	b

DC ELECTRICAL CHARACTERISTICS

$V_{EE} = V_{EE} (\text{Min.})$ to $V_{EE} (\text{Max.})$; $V_{CC} = V_{CCO} = \text{GND}$

Symbol	Parameter	$T_A = -40^\circ\text{C}$			$T_A = 0^\circ\text{C}$			$T_A = +25^\circ\text{C}$			$T_A = +85^\circ\text{C}$			Unit
		Min.	Typ.	Max.	Min.	Typ.	Max.	Min.	Typ.	Max.	Min.	Typ.	Max.	
I _{IH}	Input HIGH Current	—	—	200	—	—	200	—	—	200	—	—	200	μA
	D SEL	—	—	150	—	—	150	—	—	150	—	—	150	
I _{EE}	Power Supply Current	—	32	38	—	32	38	—	32	38	—	32	38	mA
	10E	—	32	38	—	32	38	—	32	38	—	32	38	
	100E	—	32	38	—	32	38	—	32	38	—	37	44	

AC ELECTRICAL CHARACTERISTICS

$V_{EE} = V_{EE} (\text{Min.})$ to $V_{EE} (\text{Max.})$; $V_{CC} = V_{CCO} = \text{GND}$

Symbol	Parameter	$T_A = -40^\circ\text{C}$			$T_A = 0^\circ\text{C}$			$T_A = +25^\circ\text{C}$			$T_A = +85^\circ\text{C}$			Unit
		Min.	Typ.	Max.	Min.	Typ.	Max.	Min.	Typ.	Max.	Min.	Typ.	Max.	
t _{PLH} t _{PHL}	Propagation Delay to D	220	380	550	220	380	550	220	380	550	220	380	550	ps
	SEL	425	600	800	425	600	800	425	600	800	425	600	800	
t _{skew}	Within-Device Skew ⁽¹⁾	—	70	—	—	70	—	—	70	—	—	70	—	ps
t _r t _f	Rise/Fall Time 20% to 80%	275	400	650	275	400	650	275	400	650	275	400	650	ps

NOTE:

1. Within-device skew is defined as identical transitions on similar paths through a device.

PRODUCT ORDERING CODE

Ordering Code	Package Type	Operating Range
SY10E157JC	J28-1	Commercial
SY10E157JCTR	J28-1	Commercial
SY100E157JC	J28-1	Commercial
SY100E157JCTR	J28-1	Commercial

Ordering Code	Package Type	Operating Range
SY10E157JI	J28-1	Industrial
SY10E157JITR	J28-1	Industrial
SY100E157JI	J28-1	Industrial
SY100E157JITR	J28-1	Industrial

28 LEAD PLCC (J28-1)

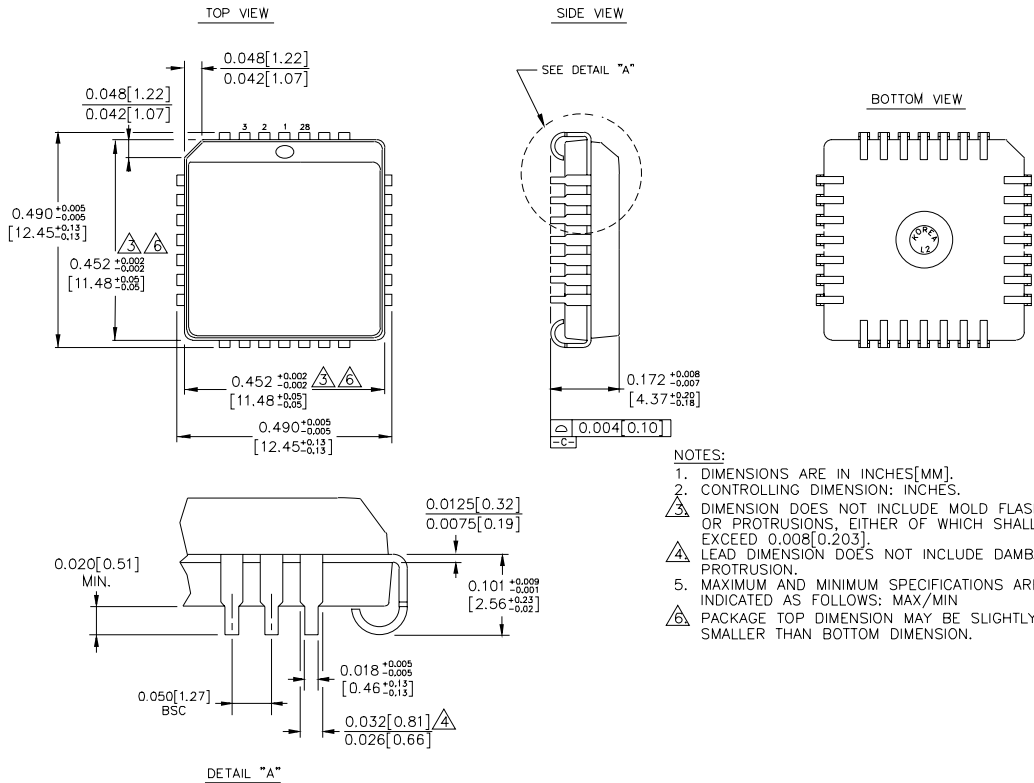

- NOTES:**
1. DIMENSIONS ARE IN INCHES[MM].
 2. CONTROLLING DIMENSION: INCHES.
 3. DIMENSION DOES NOT INCLUDE MOLD FLASH OR PROTRUSIONS, EITHER OF WHICH SHALL NOT EXCEED 0.008[0.203].
 4. LEAD DIMENSION DOES NOT INCLUDE DAMBAR PROTRUSION.
 5. MAXIMUM AND MINIMUM SPECIFICATIONS ARE INDICATED AS FOLLOWS: MAX/MIN
 6. PACKAGE TOP DIMENSION MAY BE SLIGHTLY SMALLER THAN BOTTOM DIMENSION.

Rev. 03

MICREL-SYNERGY 3250 SCOTT BOULEVARD SANTA CLARA CA 95054 USA

TEL + 1 (408) 980-9191 FAX + 1 (408) 914-7878 WEB <http://www.micrel.com>

This information is believed to be accurate and reliable, however no responsibility is assumed by Micrel for its use nor for any infringement of patents or other rights of third parties resulting from its use. No license is granted by implication or otherwise under any patent or patent right of Micrel Inc.

© 2000 Micrel Incorporated
