



# QUAD DIFFERENTIAL AND/NAND

**SY10E404**  
**SY100E404**

## FEATURES

- Differential D and Q
- Extended 100E VEE range of -4.2V to -5.5V
- 700ps max. propagation delay
- High frequency outputs
- Internal 75KΩ input pull-down resistors
- Fully compatible with Motorola 10E/100E404
- Available in 28-pin PLCC package

## DESCRIPTION

The SY10/100E404 are 4-bit differential AND/NAND devices. The differential operation of these devices make them ideal for pulse shaping applications where duty cycle skew is critical. Special design techniques were incorporated to minimize the skew between the upper and lower level gate inputs.

Because a negative 2-input NAND function is equivalent to a 2-input OR function, the differential inputs and outputs of the devices also allow for their use as fully differential 2-input OR/NOR functions.

The output RISE/FALL times of these devices are significantly faster than most other standard ECLinPS devices, resulting in an increased bandwidth.

The differential inputs have clamp structures which will force the Q output of a gate in an open input condition to go to a LOW state. Thus, inputs of unused gates can be left open and will not affect the operation of the rest of the device.

## BLOCK DIAGRAM

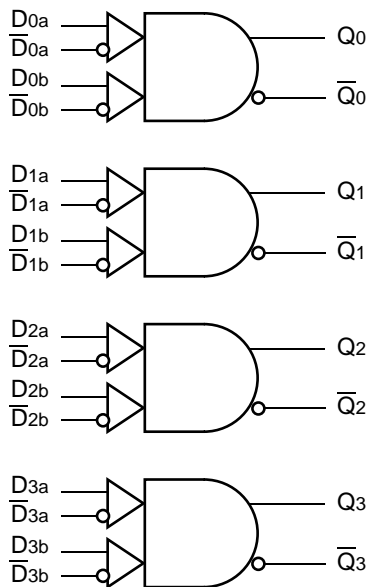

## PIN CONFIGURATION

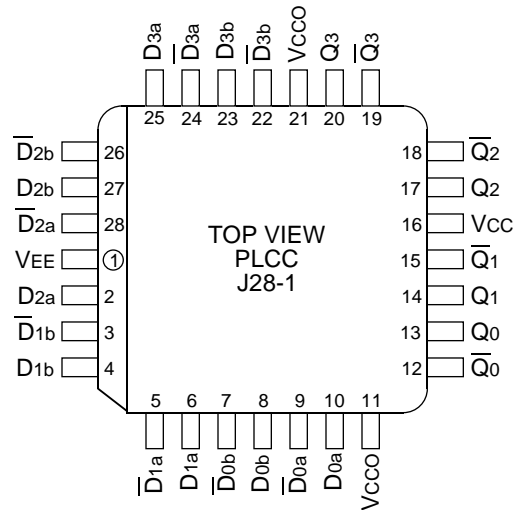

## PIN NAMES

Pin	Function
D[0:4], $\bar{D}$ [0:4]	Differential Data Inputs
Q[0:4], $\bar{Q}$ [0:4]	Differential Data Outputs
Vcco	Vcc to Output

**TRUTH TABLE**

Da	Db	Q	$\overline{D}a$	$\overline{D}b$	$\overline{Q}$
L	L	L	L	L	L
L	H	L	L	H	H
H	L	L	H	L	H
H	H	H	H	H	H

**DC ELECTRICAL CHARACTERISTICS**

VEE = VEE (Min.) to VEE (Max.); VCC = VCCO = GND

Symbol	Parameter	TA = 0°C			TA = +25°C			TA = +85°C			Unit	Condition	
		Min.	Typ.	Max.	Min.	Typ.	Max.	Min.	Typ.	Max.			
I <sub>IH</sub>	Input HIGH Current	—	—	150	—	—	150	—	—	150	μA	—	
I <sub>EE</sub>	Power Supply Current	10E	—	106	127	—	106	127	—	106	127	mA	—
		100E	—	106	127	—	106	127	—	122	146		
V <sub>PP</sub> (DC)	Input Sensitivity	50	—	—	50	—	—	50	—	—	mV	1	
V <sub>CMR</sub>	Common Mode Range	-1.5	—	0	-1.5	—	0	-1.5	—	0	V	2	

**NOTES:**

- Differential input voltage required to obtain a full ECL swing on the outputs.
- V<sub>CMR</sub> is referenced to the most positive side of the differential input signal. Normal operation is obtained when the input signals are within the V<sub>CMR</sub> range and the input swing is greater than V<sub>PP</sub> (min.) and <1V.

**AC ELECTRICAL CHARACTERISTICS**

VEE = VEE (Min.) to VEE (Max.); VCC = VCCO = GND

Symbol	Parameter	TA = 0°C			TA = +25°C			TA = +85°C			Unit	Condition
		Min.	Typ.	Max.	Min.	Typ.	Max.	Min.	Typ.	Max.		
t <sub>PLH</sub> t <sub>PHL</sub>	Propagation Delay to Output Da (Diff) Da (SE) Db (Diff) Db (SE)	350 300 375 325	475 475 500 500	650 700 675 725	350 300 375 325	475 475 500 500	650 700 675 725	350 300 375 325	475 475 500 500	650 700 675 725	ps	—
t <sub>skew</sub>	Within-Device Skew	—	50	—	—	50	—	—	50	—	ps	1
V <sub>PP</sub> (AC)	Minimum Input Swing	150	—	—	150	—	—	150	—	—	mV	2
t <sub>r</sub> t <sub>f</sub>	Rise/Fall Time 20–80%	150	—	400	150	—	400	150	—	400	ps	—

**NOTES:**

- Within-device skew is defined as identical transitions on similar paths through a device.
- Minimum input swing for which AC parameters are guaranteed.

**PRODUCT ORDERING CODE**

Ordering Code	Package Type	Operating Range
SY10E404JC	J28-1	Commercial
SY10E404JCTR	J28-1	Commercial
SY100E404JC	J28-1	Commercial
SY100E404JCTR	J28-1	Commercial

**28 LEAD PLCC (J28-1)**

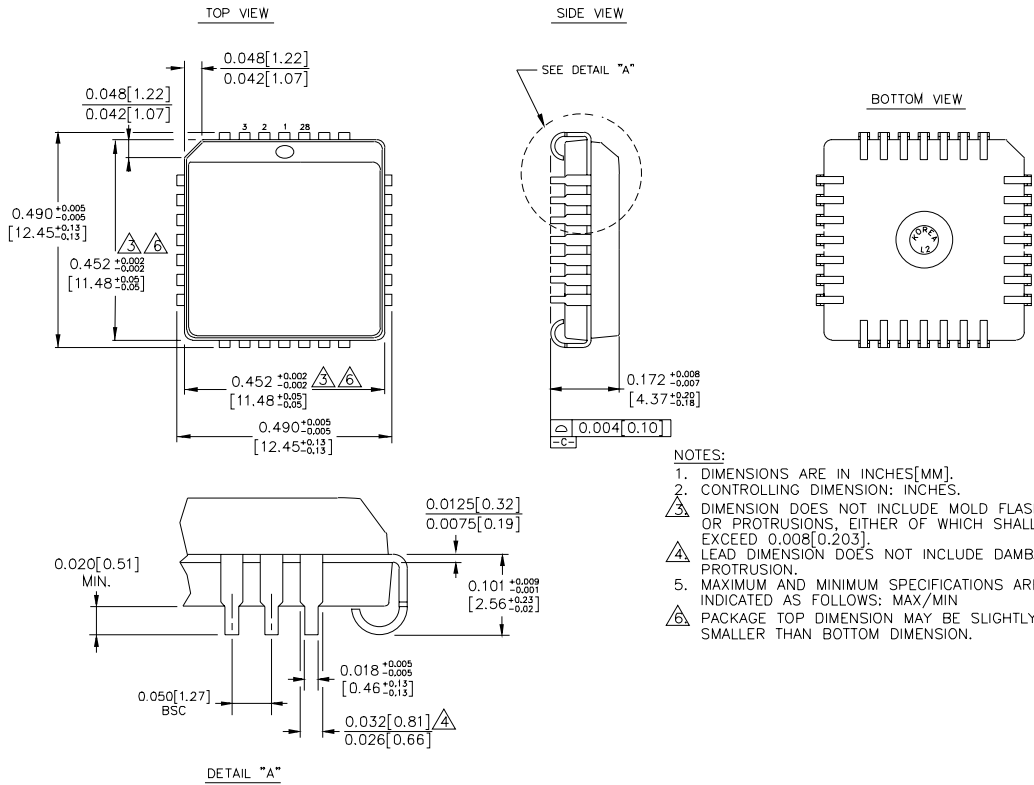

Rev. 03

---

**MICREL-SYNERGY 3250 SCOTT BOULEVARD SANTA CLARA CA 95054 USA**

TEL + 1 (408) 980-9191 FAX + 1 (408) 914-7878 WEB <http://www.micrel.com>

This information is believed to be accurate and reliable, however no responsibility is assumed by Micrel for its use nor for any infringement of patents or other rights of third parties resulting from its use. No license is granted by implication or otherwise under any patent or patent right of Micrel Inc.

© 2000 Micrel Incorporated

---