



Document Title

4Mx4 bit Dynamic RAM with EDO Page Mode

Revision History

<u>Revision No</u>	<u>History</u>	<u>Draft Date</u>	<u>Remark</u>
0A	Initial Draft	September 4,2001	

The attached datasheets are provided by ICSI. Integrated Circuit Solution Inc reserve the right to change the specifications and products. ICSI will answer to your questions about device. If you have any questions, please contact the ICSI offices.

4M x 4 (16-MBIT) DYNAMIC RAM WITH EDO PAGE MODE

FEATURES

- Extended Data-Out (EDO) Page Mode access cycle
- TTL compatible inputs and outputs
- Refresh Interval:
-- 2,048 cycles/32 ms
- Refresh Mode: $\overline{\text{RAS}}$ -Only, $\overline{\text{CAS}}$ -before- $\overline{\text{RAS}}$ (CBR), and Hidden
- JEDEC standard pinout
- Single power supply:
5V \pm 10% or 3.3V \pm 10%
- Self Refresh 2048 cycles for S version
- Low power for L version.

DESCRIPTION

The *ICSI* 44002 Series is a 4,194,304 x 4-bit high-performance CMOS Dynamic Random Access Memory. These devices offer an accelerated cycle access called EDO Page Mode. EDO Page Mode allows 2,048 random accesses within a single row with access cycle time as short as 20 ns per 4-bit word.

These features make the 44002 Series ideally suited for high-bandwidth graphics, digital signal processing, high-performance computing systems, and peripheral applications.

The 44002 Series is packaged in a 24-pin 300mil SOJ and a 24 pin TSOP-2

PRODUCT SERIES OVERVIEW

Part No.	Refresh	Voltage
IS41C44002A	2K	5V \pm 10%
IS41C44002AS(L)	2K	5V \pm 10%
IS41LV44002A	2K	3.3V \pm 10%
IS41LV44002AS(L)	2K	3.3V \pm 10%

KEY TIMING PARAMETERS

Parameter	-50	-60	Unit
RAS Access Time (t_{RAC})	50	60	ns
CAS Access Time (t_{CAC})	13	15	ns
Column Address Access Time (t_{AA})	25	30	ns
EDO Page Mode Cycle Time (t_{PC})	20	25	ns
Read/Write Cycle Time (t_{RC})	84	104	ns

PIN CONFIGURATION

24 Pin SOJ, TSOP-2

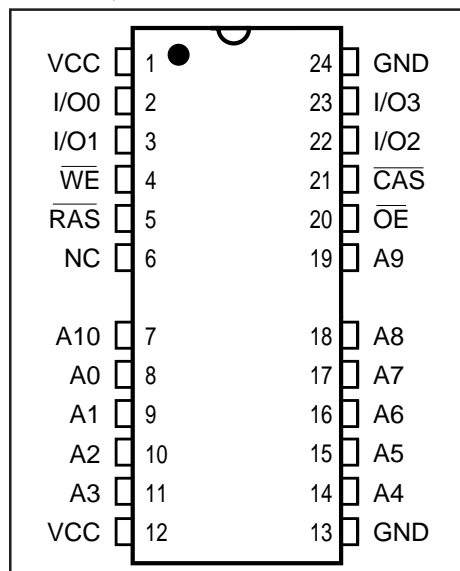

PIN DESCRIPTIONS

A0-A10	Address Inputs (2K Refresh)
I/O0-3	Data Inputs/Outputs
$\overline{\text{WE}}$	Write Enable
$\overline{\text{OE}}$	Output Enable
$\overline{\text{RAS}}$	Row Address Strobe
$\overline{\text{CAS}}$	Column Address Strobe
Vcc	Power
GND	Ground
NC	No Connection

FUNCTIONAL BLOCK DIAGRAM

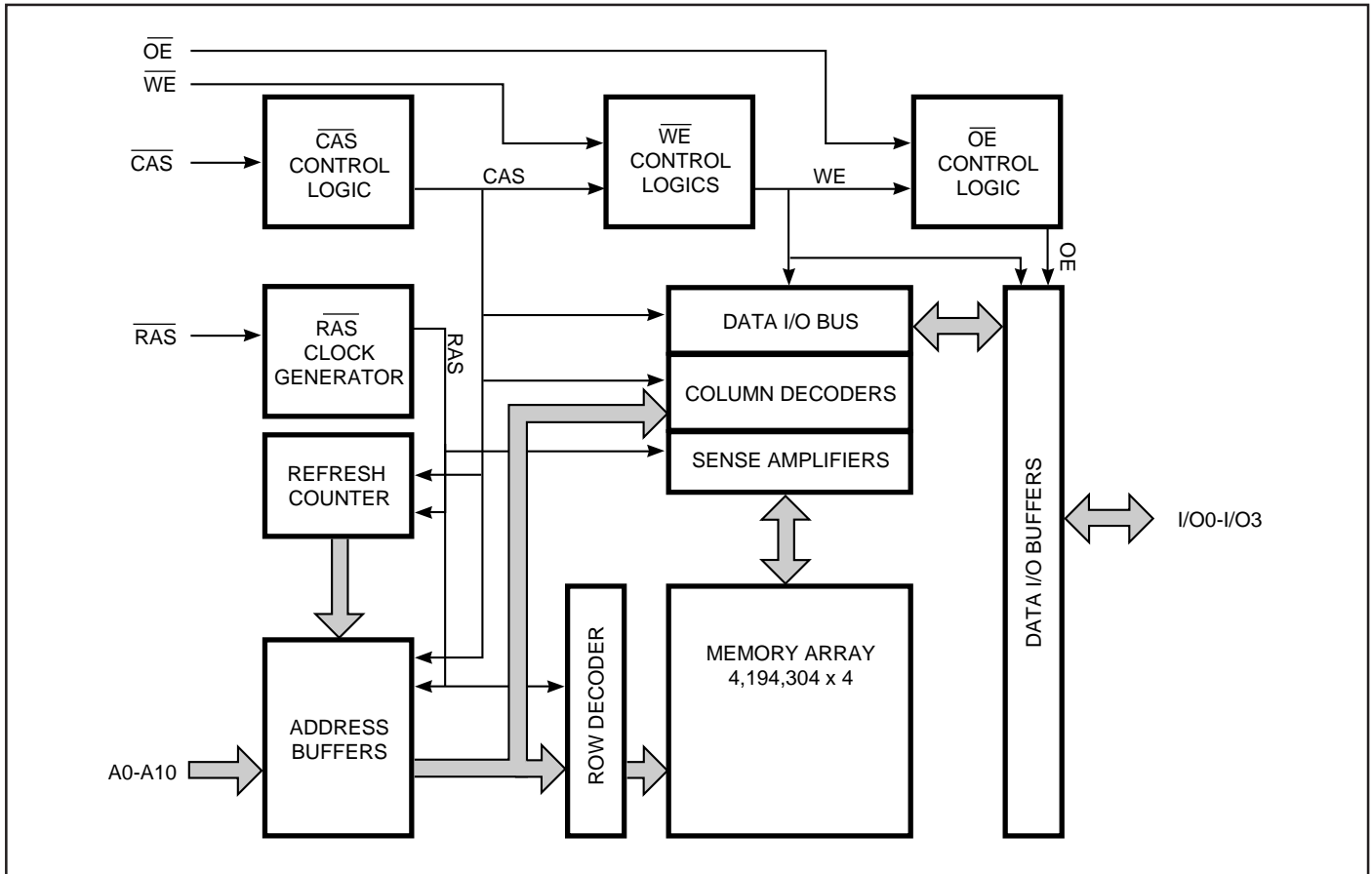

TRUTH TABLE

Function		RAS	CAS	WE	OE	Address tr/tc	I/O
Standby		H	H	X	X	X	High-Z
Read		L	L	H	L	ROW/COL	DoUT
Write: Word (Early Write)		L	L	L	X	ROW/COL	DiN
Read-Write		L	L	H→L	L→H	ROW/COL	DoUT, DiN
EDO Page-Mode Read	1st Cycle:	L	H→L	H	L	ROW/COL	DoUT
	2nd Cycle:	L	H→L	H	L	NA/COL	DoUT
EDO Page-Mode Write	1st Cycle:	L	H→L	L	X	ROW/COL	DiN
	2nd Cycle:	L	H→L	L	X	NA/COL	DiN
EDO Page-Mode Read-Write	1st Cycle:	L	H→L	H→L	L→H	ROW/COL	DoUT, DiN
	2nd Cycle:	L	H→L	H→L	L→H	NA/COL	DoUT, DiN
Hidden Refresh	Read	L→H→L	L	H	L	ROW/COL	DoUT
	Write ⁽¹⁾	L→H→L	L	L	X	ROW/COL	DiN
RAS-Only Refresh		L	H	X	X	ROW/NA	High-Z
CBR Refresh		H→L	L	H	X	X	High-Z

Note:

1. EARLY WRITE only.

Functional Description

The IC41C44002A and IC41LV44002A are CMOS DRAMs optimized for high-speed bandwidth, low power applications. During READ or WRITE cycles, each bit is uniquely addressed through the 11 address bits. These are entered 11 bits (A0-A10) at a time for the 2K refresh device. The row address is latched by the Row Address Strobe (RAS). The column address is latched by the Column Address Strobe (CAS). RAS is used to latch the first 11 bits and CAS is used to latch the latter 11 bits.

Memory Cycle

A memory cycle is initiated by bringing $\overline{\text{RAS}}$ LOW and it is terminated by returning both RAS and CAS HIGH. To ensure proper device operation and data integrity any memory cycle, once initiated, must not be ended or aborted before the minimum t_{RAS} time has expired. A new cycle must not be initiated until the minimum precharge time t_{RP} , t_{CP} has elapsed.

Read Cycle

A read cycle is initiated by the falling edge of $\overline{\text{CAS}}$ or $\overline{\text{OE}}$, whichever occurs last, while holding WE HIGH. The column address must be held for a minimum time specified by t_{AR} . Data Out becomes valid only when t_{RAC} , t_{AA} , t_{CAC} and t_{OE} are all satisfied. As a result, the access time is dependent on the timing relationships between these parameters.

Write Cycle

A write cycle is initiated by the falling edge of $\overline{\text{CAS}}$ and $\overline{\text{WE}}$, whichever occurs last. The input data must be valid at or before the falling edge of CAS or WE, whichever occurs last.

Refresh Cycle

To retain data, 2,048 refresh cycles are required in each 32 ms period. There are two ways to refresh the memory:

1. By clocking each of the 2,048 row addresses (A0 through A10) with $\overline{\text{RAS}}$ at least once every 32 ms. Any read, write, read-modify-write or $\overline{\text{RAS}}$ -only cycle refreshes the addressed row.
2. Using a $\overline{\text{CAS}}$ -before- $\overline{\text{RAS}}$ refresh cycle. $\overline{\text{CAS}}$ -before- $\overline{\text{RAS}}$ refresh is activated by the falling edge of $\overline{\text{RAS}}$, while holding $\overline{\text{CAS}}$ LOW. In $\overline{\text{CAS}}$ -before- $\overline{\text{RAS}}$ refresh cycle, an internal 11-bit counter provides the row addresses and the external address inputs are ignored.

$\overline{\text{CAS}}$ -before- $\overline{\text{RAS}}$ is a refresh-only mode and no data access or device selection is allowed. Thus, the output remains in the High-Z state during the cycle.

Self Refresh Cycle⁽¹⁾

The Self Refresh allows the user a dynamic refresh, data retention mode at the extended refresh period of 64 ms. i. e., 32 μs per row when using distributed CBR refreshes. The feature also allows the user the choice of a fully static, low power data retention mode. The optional Self Refresh feature is initiated by performing a CBR Refresh cycle and holding RAS LOW for the specified t_{RAS} .

The Self Refresh mode is terminated by driving $\overline{\text{RAS}}$ HIGH for a minimum time of t_{RPS} . This delay allows for the completion of any internal refresh cycles that may be in process at the time of the RAS LOW-to-HIGH transition. If the DRAM controller uses a distributed refresh sequence, a burst refresh is not required upon exiting Self Refresh.

However, if the DRAM controller utilizes a $\overline{\text{RAS}}$ -only or burst refresh sequence, all 2048 rows must be refreshed within the average internal refresh rate, prior to the resumption of normal operation.

Power-On

After application of the V_{CC} supply, an initial pause of 200 μs is required followed by a minimum of eight initialization cycles (any combination of cycles containing a RAS signal).

During power-on, it is recommended that $\overline{\text{RAS}}$ track with V_{CC} or be held at a valid V_{IH} to avoid current surges.

Note:

1. Self Refresh is for S version only.

ABSOLUTE MAXIMUM RATINGS⁽¹⁾

Symbol	Parameters	Rating	Unit
V _T	Voltage on Any Pin Relative to GND	5V	-1.0 to +7.0
		3.3V	-0.5 to +4.6
V _{CC}	Supply Voltage	5V	-1.0 to +7.0
		3.3V	-0.5 to +4.6
I _{OUT}	Output Current	50	mA
P _D	Power Dissipation	1	W
T _A	Commercial Operation Temperature	0 to +70	°C
T _{STG}	Storage Temperature	-55 to +125	°C

Note:

1. Stress greater than those listed under ABSOLUTE MAXIMUM RATINGS may cause permanent damage to the device. This is a stress rating only and functional operation of the device at these or any other conditions above those indicated in the operational sections of this specification is not implied. Exposure to absolute maximum rating conditions for extended periods may affect reliability.

RECOMMENDED OPERATING CONDITIONS (Voltages are referenced to GND.)

Symbol	Parameter	Min.	Typ.	Max.	Unit
V _{CC}	Supply Voltage	5V	4.5	5.0	5.5
		3.3V	3.0	3.3	3.6
V _{IH}	Input High Voltage	5V	2.4	-	V _{CC} + 1.0
		3.3V	2.0	-	V _{CC} + 0.3
V _{IL}	Input Low Voltage	5V	-1.0	-	0.8
		3.3V	-0.3	-	0.8
T _A	Commercial Ambient Temperature	0	-	70	°C

CAPACITANCE^(1,2)

Symbol	Parameter	Max.	Unit
C _{IN1}	Input Capacitance: A0-A10(A11)	5	pF
C _{IN2}	Input Capacitance: RAS, CAS, WE, OE	7	pF
C _{IO}	Data Input/Output Capacitance: I/O0-I/O3	7	pF

Notes:

1. Tested initially and after any design or process changes that may affect these parameters.
2. Test conditions: T_A = 25°C, f = 1 MHz.

ELECTRICAL CHARACTERISTICS⁽¹⁾

(Recommended Operating Conditions unless otherwise noted.)

Symbol	Parameter	Test Condition	Speed	Min.	Max.	Unit
I _{IL}	Input Leakage Current	Any input $0V \leq V_{IN} \leq V_{CC}$ Other inputs not under test = 0V		-5	5	μA
I _{IO}	Output Leakage Current	Output is disabled (Hi-Z) $0V \leq V_{OUT} \leq V_{CC}$		-5	5	μA
V _{OH}	Output High Voltage Level	I _{OH} = -5.0 mA with V _{CC} =5V I _{OH} = -2.0 mA with V _{CC} =3.3V		2.4	-	V
V _{OL}	Output Low Voltage Level	I _{OL} = 4.2 mA with V _{CC} =5V I _{OL} = 2 mA with V _{CC} =3.3V		-	0.4	V
I _{CC1}	Standby Current: TTL	$\overline{RAS}, \overline{CAS} \geq V_{IH}$	5V 3.3V	- -	2 2	mA
I _{CC2}	Standby Current: CMOS	$\overline{RAS}, \overline{CAS} \geq V_{CC} - 0.2V$	5V 3.3V	- -	1 0.5	mA
I _{CC3}	Operating Current: Random Read/Write ^(2,3,4) Average Power Supply Current	$\overline{RAS}, \overline{CAS}$, Address Cycling, t _{RC} = t _{RC} (min.)	-50 -60	- -	120 110	mA
I _{CC4}	Operating Current: EDO Page Mode ^(2,3,4) Average Power Supply Current	$\overline{RAS} = V_{IL}, \overline{CAS}$, Cycling t _{PC} = t _{PC} (min.)	-50 -60	- -	90 80	mA
I _{CC5}	Refresh Current: CBR ^(2,3,5) Average Power Supply Current	$\overline{RAS}, \overline{CAS}$ Cycling t _{RC} = t _{RC} (min.)	-50 -60	- -	120 110	mA
I _{CCS}	Self Refresh current ⁽⁶⁾	Self Refresh Mode	5V, normal version 5V, L version 3.3V, normal version 3.3, L version		500 350 450 350	μA

Notes:

1. An initial pause of 200 μs is required after power-up followed by eight \overline{RAS} refresh cycles (\overline{RAS} -Only or CBR) before proper device operation is assured. The eight \overline{RAS} cycles wake-up should be repeated any time the t_{REF} refresh requirement is exceeded.
2. Dependent on cycle rates.
3. Specified values are obtained with minimum cycle time and the output open.
4. Column-address is changed once each EDO page cycle.
5. Enables on-chip refresh and address counters.
6. I_{CCS} is for S version only.

AC CHARACTERISTICS^(1,2,3,4,5,6)

(Recommended Operating Conditions unless otherwise noted.)

Symbol	Parameter	-50		-60		Units
		Min.	Max.	Min.	Max.	
t _{RC}	Random READ or WRITE Cycle Time	84	–	104	–	ns
t _{RAC}	Access Time from $\overline{\text{RAS}}$ ^(6, 7)	–	50	–	60	ns
t _{CAC}	Access Time from $\overline{\text{CAS}}$ ^(6, 8, 15)	–	14	–	15	ns
t _{AA}	Access Time from Column-Address ⁽⁶⁾	–	25	–	30	ns
t _{RAS}	$\overline{\text{RAS}}$ Pulse Width	50	10K	60	10K	ns
t _{RP}	$\overline{\text{RAS}}$ Precharge Time	30	–	40	–	ns
t _{CAS}	$\overline{\text{CAS}}$ Pulse Width ⁽²³⁾	8	10K	10	10K	ns
t _{CP}	$\overline{\text{CAS}}$ Precharge Time ⁽⁹⁾	10	–	10	–	ns
t _{CSH}	$\overline{\text{CAS}}$ Hold Time ⁽²¹⁾	38	–	40	–	ns
t _{RCD}	$\overline{\text{RAS}}$ to $\overline{\text{CAS}}$ Delay Time ^(10, 20)	12	37	14	45	ns
t _{ASR}	Row-Address Setup Time	0	–	0	–	ns
t _{RAH}	Row-Address Hold Time	8	–	10	–	ns
t _{ASC}	Column-Address Setup Time ⁽²⁰⁾	0	–	0	–	ns
t _{CAH}	Column-Address Hold Time ⁽²⁰⁾	8	–	10	–	ns
t _{RAD}	$\overline{\text{RAS}}$ to Column-Address Delay Time ⁽¹¹⁾	10	25	12	30	ns
t _{RAL}	Column-Address to $\overline{\text{RAS}}$ Lead Time	25	–	30	–	ns
t _{RSH}	$\overline{\text{RAS}}$ Hold Time	8	–	10	–	ns
t _{RHCP}	$\overline{\text{RAS}}$ Hold Time from $\overline{\text{CAS}}$ Precharge	30	–	35	–	ns
t _{CLZ}	$\overline{\text{CAS}}$ to Output in Low-Z ^(15, 24)	0	–	0	–	ns
t _{CRP}	$\overline{\text{CAS}}$ to $\overline{\text{RAS}}$ Precharge Time ⁽²¹⁾	5	–	5	–	ns
t _{OD}	Output Disable Time ^(19, 24)	0	15	0	15	ns
t _{OE}	Output Enable Time ^(15, 16)	–	12	–	15	ns
t _{OE D}	Output Enable Data Delay (Write)	20	–	20	–	ns
t _{OE H C}	$\overline{\text{OE}}$ HIGH Hold Time from $\overline{\text{CAS}}$ HIGH	5	–	5	–	ns
t _{OE P}	$\overline{\text{OE}}$ HIGH Pulse Width	10	–	10	–	ns
t _{RCS}	Read Command Setup Time ^(17, 20)	0	–	0	–	ns
t _{RRH}	Read Command Hold Time (referenced to $\overline{\text{RAS}}$) ⁽¹²⁾	0	–	0	–	ns
t _{RCH}	Read Command Hold Time (referenced to $\overline{\text{CAS}}$) ^(12, 17, 21)	0	–	0	–	ns
t _{WCH}	Write Command Hold Time ⁽¹⁷⁾	8	–	10	–	ns
t _{WP}	Write Command Pulse Width ⁽¹⁷⁾	8	–	10	–	ns
t _{WPZ}	$\overline{\text{WE}}$ Pulse Widths to Disable Outputs	10	–	10	–	ns
t _{RWL}	Write Command to $\overline{\text{RAS}}$ Lead Time ⁽¹⁷⁾	13	–	15	–	ns
t _{CWL}	Write Command to $\overline{\text{CAS}}$ Lead Time ^(17, 21)	8	–	10	–	ns
t _{WCS}	Write Command Setup Time ^(14, 17, 20)	0	–	0	–	ns

AC CHARACTERISTICS (Continued)^(1,2,3,4,5,6)

(Recommended Operating Conditions unless otherwise noted.)

Symbol	Parameter	-50		-60		Units
		Min.	Max.	Min.	Max.	
t _{OEH}	\overline{OE} Hold Time from \overline{WE} during READ-MODIFY-WRITE cycle ⁽¹⁸⁾	8	–	10	–	ns
t _{DS}	Data-In Setup Time ^(15, 22)	0	–	0	–	ns
t _{DH}	Data-In Hold Time ^(15, 22)	8	–	10	–	ns
t _{RWC}	READ-MODIFY-WRITE Cycle Time	108	–	133	–	ns
t _{RWD}	RAS to \overline{WE} Delay Time during READ-MODIFY-WRITE Cycle ⁽¹⁴⁾	64	–	77	–	ns
t _{CWD}	CAS to \overline{WE} Delay Time ^(14, 20)	26	–	32	–	ns
t _{AWD}	Column-Address to \overline{WE} Delay Time ⁽¹⁴⁾	39	–	47	–	ns
t _{PC}	EDO Page Mode READ or WRITE Cycle Time	20	–	25	–	ns
t _{RASP}	RAS Pulse Width in EDO Page Mode	50	100K	60	100K	ns
t _{CPA}	Access Time from CAS Precharge ⁽¹⁵⁾	–	30	–	35	ns
t _{PRWC}	EDO Page Mode READ-WRITE Cycle Time	56	–	68	–	ns
t _{COH}	Data Output Hold after \overline{CAS} LOW	5	–	5	–	ns
t _{OFF}	Output Buffer Turn-Off Delay from CAS or RAS ^(13,15,19, 24)	0	12	0	15	ns
t _{WHZ}	Output Disable Delay from \overline{WE}	3	10	3	10	ns
t _{CSR}	CAS Setup Time (CBR REFRESH) ^(20, 25)	5	–	5	–	ns
t _{CHR}	CAS Hold Time (CBR REFRESH) ^(21, 25)	8	–	10	–	ns
t _{RPC}	RAS to CAS Precharge Time	5	–	5	–	ns
t _{ORD}	\overline{OE} Setup Time prior to \overline{RAS} during HIDDEN REFRESH Cycle	0	–	0	–	ns
t _{REF}	Auto Refresh Period	2,048 Cycles	–	32	–	ms
t _r	Transition Time (Rise or Fall) ^(2, 3)	1	50	1	50	ns

AC TEST CONDITIONS

Output load: Two TTL Loads and 100 pF ($V_{CC}=5.0V \pm 10\%$)

One TTL Loads and 100 pF ($V_{CC}=3.3V \pm 10\%$)

Input timing reference levels: $V_{IH} = 2.4V$, $V_{IL} = 0.8V$

Output timing reference levels: $V_{OH} = 2.0V$, $V_{OL} = 0.8V$

Notes:

1. An initial pause of 200 μ s is required after power-up followed by eight $\overline{\text{RAS}}$ refresh cycle ($\overline{\text{RAS}}$ -Only or CBR) before proper device operation is assured. The eight $\overline{\text{RAS}}$ cycles wake-up should be repeated any time the t_{REF} refresh requirement is exceeded.
2. V_{IH} (MIN) and V_{IL} (MAX) are reference levels for measuring timing of input signals. Transition times, are measured between V_{IH} and V_{IL} (or between V_{IL} and V_{IH}) and assume to be 1 ns for all inputs.
3. In addition to meeting the transition rate specification, all input signals must transit between V_{IH} and V_{IL} (or between V_{IL} and V_{IH}) in a monotonic manner.
4. If $\overline{\text{CAS}}$ and $\overline{\text{RAS}} = V_{\text{IH}}$, data output is High-Z.
5. If $\overline{\text{CAS}} = V_{\text{IL}}$, data output may contain data from the last valid READ cycle.
6. Measured with a load equivalent to one TTL gate and 50 pF.
7. Assumes that $\leq t_{\text{RCD}}$ After appli t_{RCD} (MAX). If t_{RCD} is greater than the maximum recommended value shown in this table, t_{RAC} will increase by the amount that t_{RCD} exceeds the value shown.
8. Assumes that $t_{\text{RCD}} \geq t_{\text{RCD}}$ (MAX).
9. If $\overline{\text{CAS}}$ is LOW at the falling edge of $\overline{\text{RAS}}$, data out will be maintained from the previous cycle. To initiate a new cycle and clear the data output buffer, $\overline{\text{CAS}}$ and $\overline{\text{RAS}}$ must be pulsed for t_{CP} .
10. Operation with the t_{RCD} (MAX) limit ensures that t_{RAC} (MAX) can be met. t_{RCD} (MAX) is specified as a reference point only; if t_{RCD} is greater than the specified t_{RCD} (MAX) limit, access time is controlled exclusively by t_{CAC} .
11. Operation within the t_{RAD} (MAX) limit ensures that t_{RCD} (MAX) can be met. t_{RAD} (MAX) is specified as a reference point only; if t_{RAD} is greater than the specified t_{RAD} (MAX) limit, access time is controlled exclusively by t_{AA} .
12. Either t_{RCH} or t_{RRH} must be satisfied for a READ cycle.
13. t_{OFF} (MAX) defines the time at which the output achieves the open circuit condition; it is not a reference to V_{OH} or V_{OL} .
14. t_{WCS} , t_{RWD} , t_{AWD} and t_{CWD} are restrictive operating parameters in LATE WRITE and READ-MODIFY-WRITE cycle only. If $t_{\text{WCS}} \geq t_{\text{WCS}}$ (MIN), the cycle is an EARLY WRITE cycle and the data output will remain open circuit throughout the entire cycle. If $t_{\text{RWD}} \geq t_{\text{RWD}}$ (MIN), $t_{\text{AWD}} \geq t_{\text{AWD}}$ (MIN) and $t_{\text{CWD}} \geq t_{\text{CWD}}$ (MIN), the cycle is a READ-WRITE cycle and the data output will contain data read from the selected cell. If neither of the above conditions is met, the state of I/O (at access time and until $\overline{\text{CAS}}$ and $\overline{\text{RAS}}$ or $\overline{\text{OE}}$ go back to V_{IH}) is indeterminate. $\overline{\text{OE}}$ held HIGH and $\overline{\text{WE}}$ taken LOW after $\overline{\text{CAS}}$ goes LOW result in a LATE WRITE ($\overline{\text{OE}}$ -controlled) cycle.
15. Output parameter (I/O) is referenced to corresponding $\overline{\text{CAS}}$ input.
16. During a READ cycle, if $\overline{\text{OE}}$ is LOW then taken HIGH before $\overline{\text{CAS}}$ goes HIGH, I/O goes open. If $\overline{\text{OE}}$ is tied permanently LOW, a LATE WRITE or READ-MODIFY-WRITE is not possible.
17. Write command is defined as $\overline{\text{WE}}$ going low.
18. LATE WRITE and READ-MODIFY-WRITE cycles must have both t_{OD} and t_{OEH} met ($\overline{\text{OE}}$ HIGH during WRITE cycle) in order to ensure that the output buffers will be open during the WRITE cycle. The I/Os will provide the previously written data if $\overline{\text{CAS}}$ remains LOW and $\overline{\text{OE}}$ is taken back to LOW after t_{OEH} is met.
19. The I/Os are in open during READ cycles once t_{OD} or t_{OFF} occur.
20. Determined by falling edge of $\overline{\text{CAS}}$.
21. Determined by rising edge of $\overline{\text{CAS}}$.
22. These parameters are referenced to $\overline{\text{CAS}}$ leading edge in EARLY WRITE cycles and $\overline{\text{WE}}$ leading edge in LATE WRITE or READ-MODIFY-WRITE cycles.
23. $\overline{\text{CAS}}$ must meet minimum pulse width.
24. The 3 ns minimum is a parameter guaranteed by design.
25. Enables on-chip refresh and address counters.

READ CYCLE

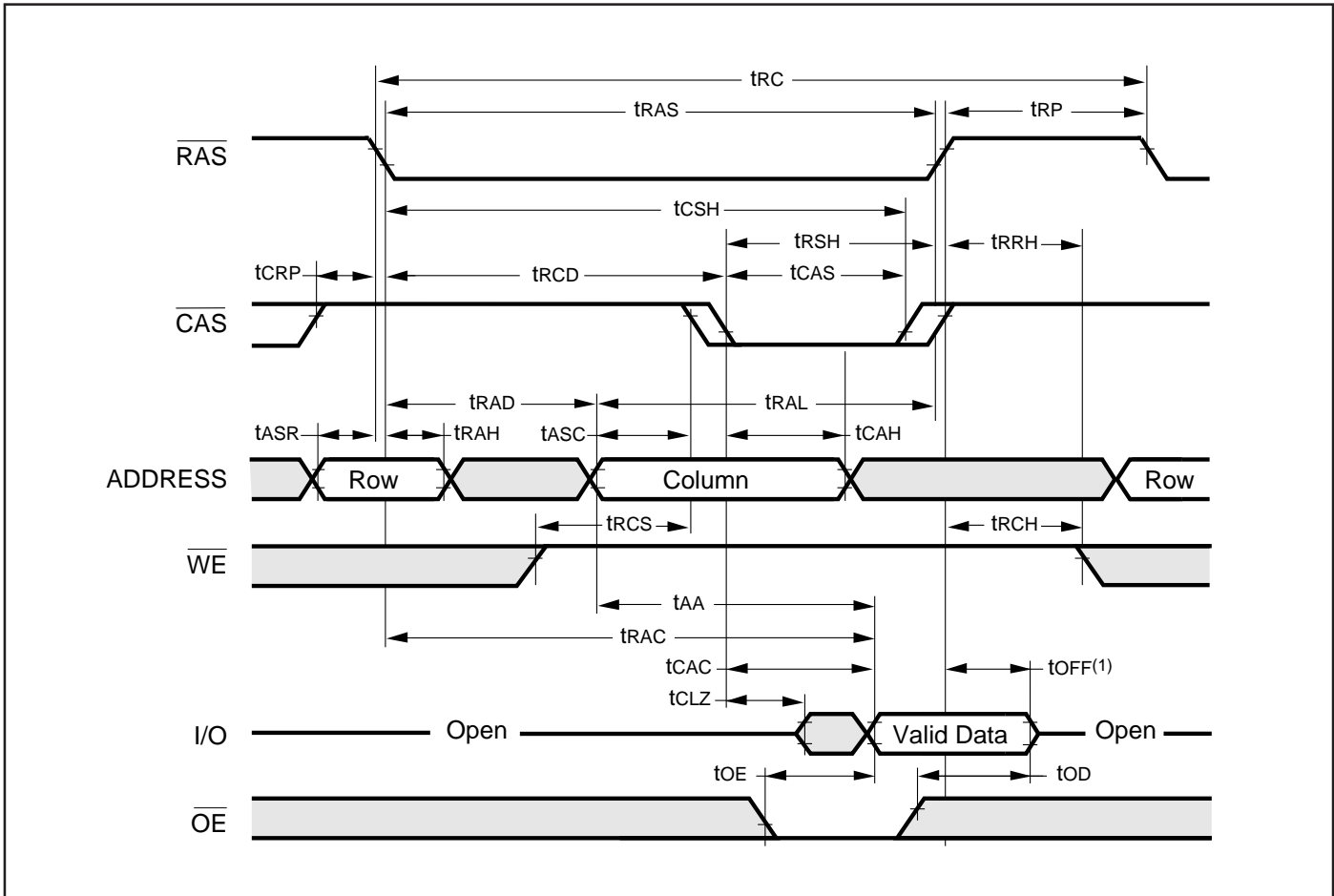

Note:

1. t_{OFF} is referenced from rising edge of \overline{RAS} or \overline{CAS} , whichever occurs last.

EARLY WRITE CYCLE (\overline{OE} = DON'T CARE)

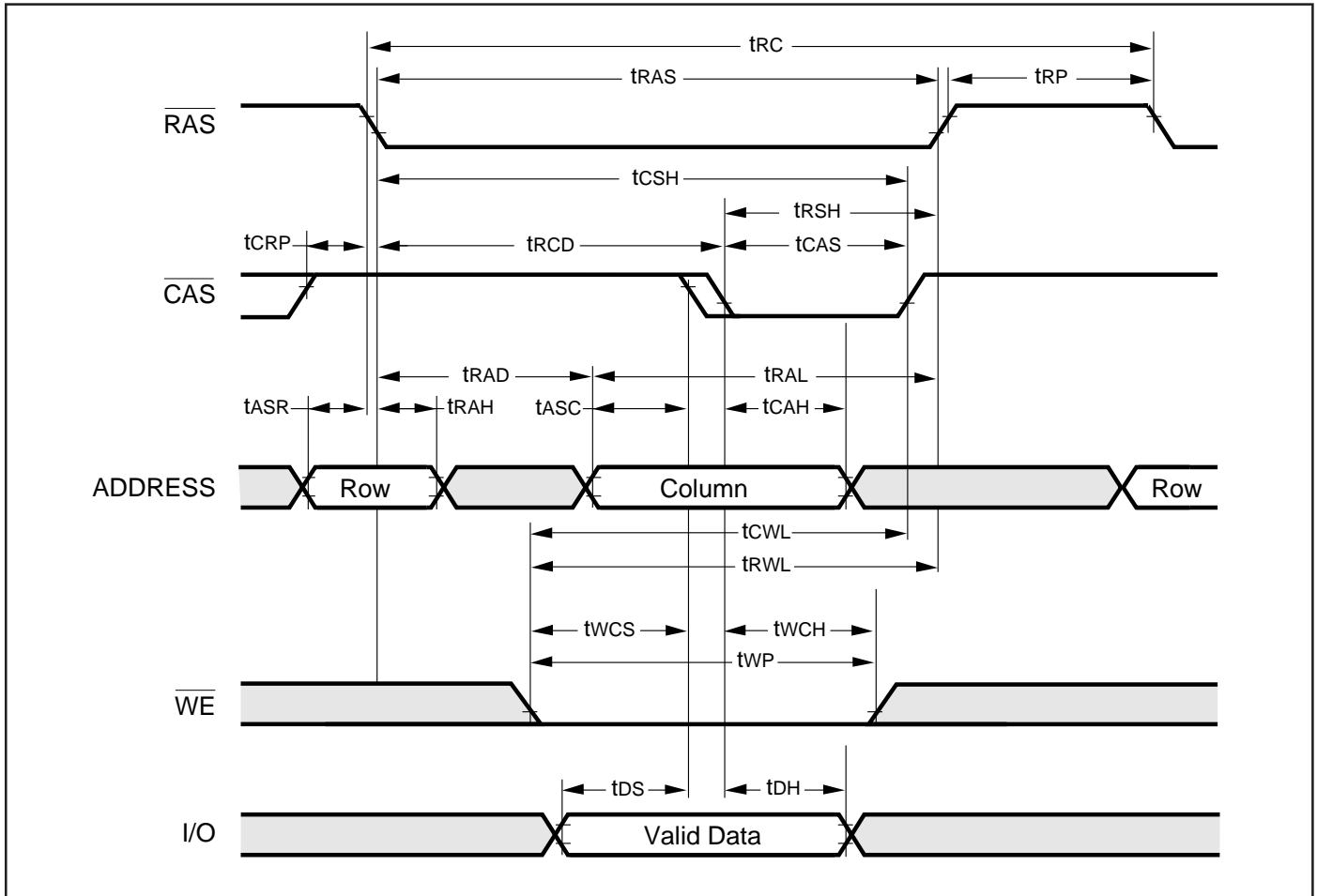

READ WRITE CYCLE (LATE WRITE and READ-MODIFY-WRITE Cycles)

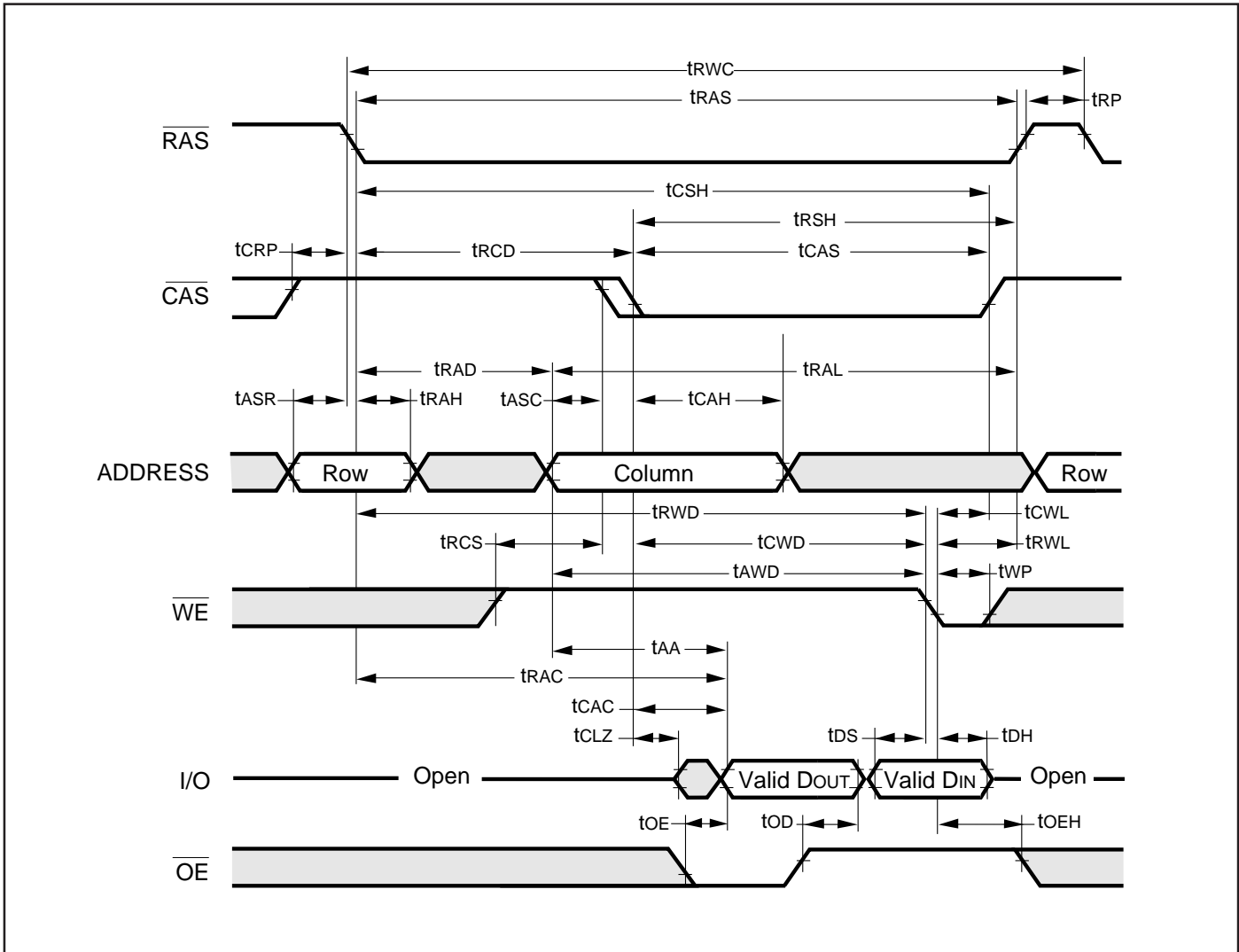

EDO-PAGE-MODE EARLY-WRITE CYCLE

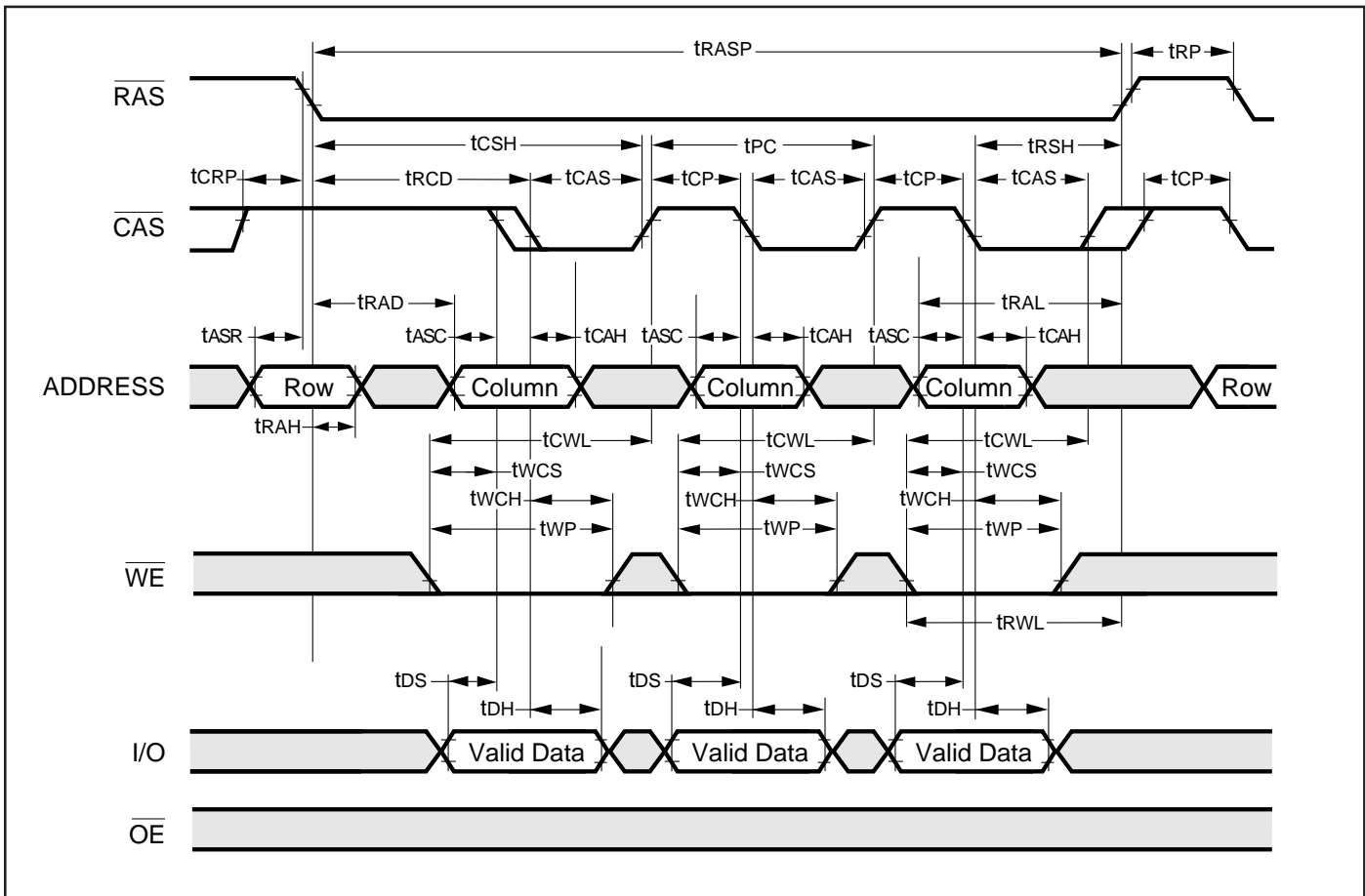

EDO-PAGE-MODE READ-EARLY-WRITE CYCLE (Psuedo READ-MODIFY WRITE)

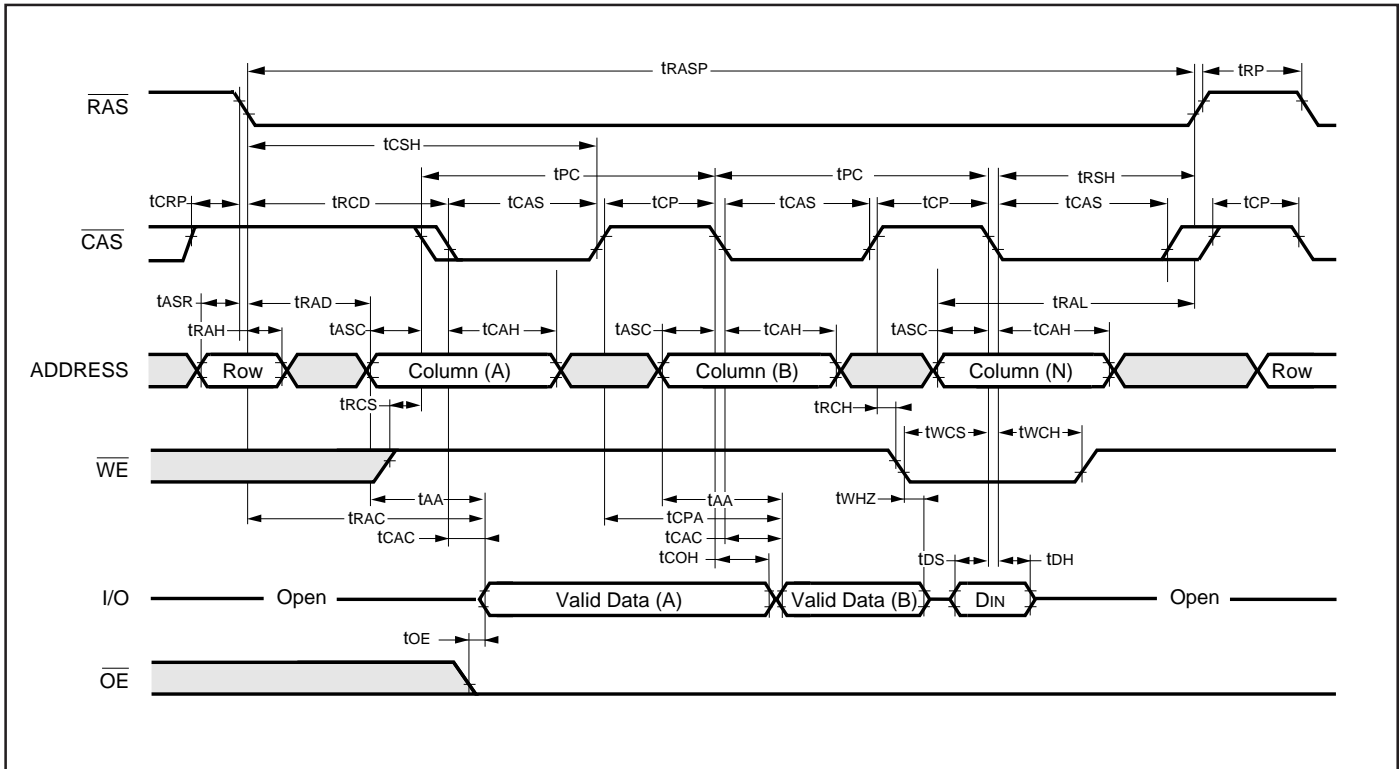

AC WAVEFORMS

READ CYCLE (With \overline{WE} -Controlled Disable)

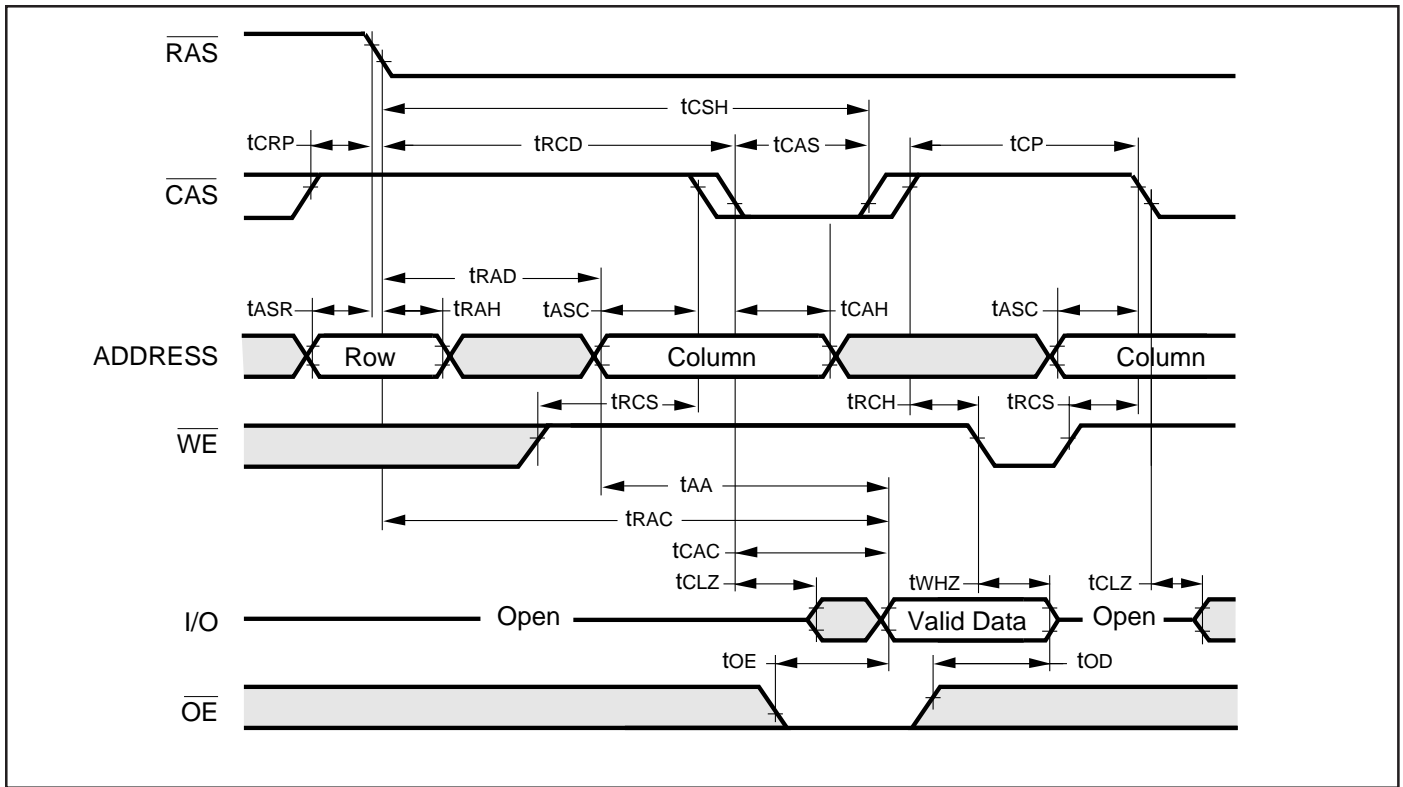

RAS-ONLY REFRESH CYCLE (\overline{OE} , \overline{WE} = DON'T CARE)

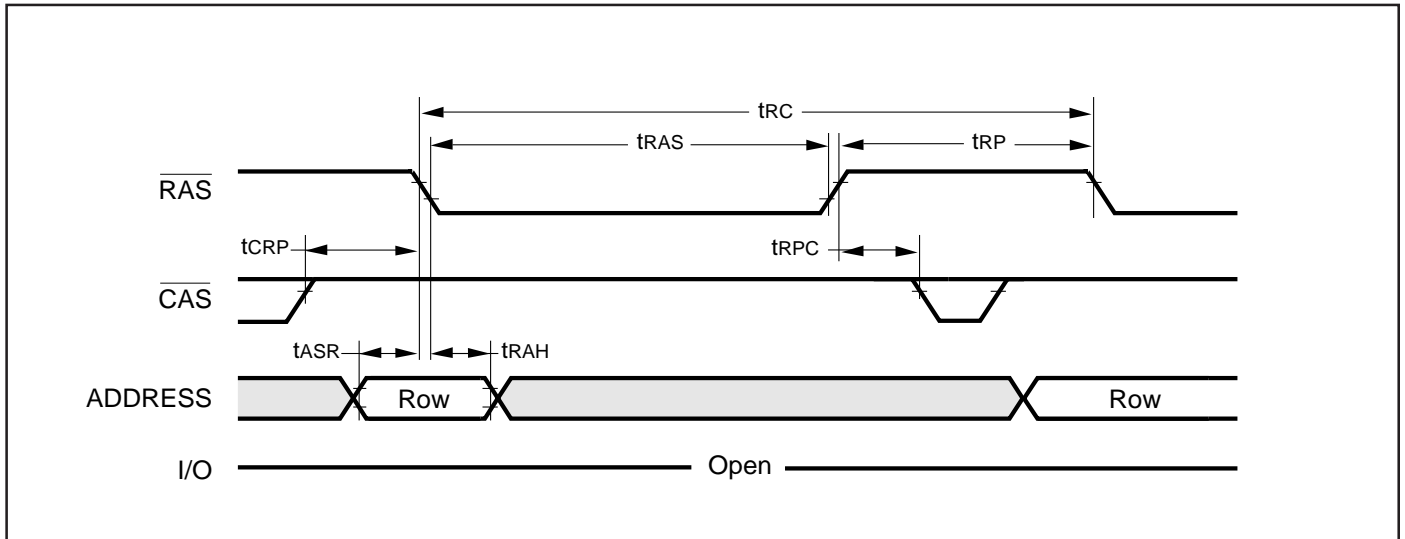

CBR REFRESH CYCLE (Addresses; \overline{OE} = DON'T CARE, \overline{WE} =HIGH)

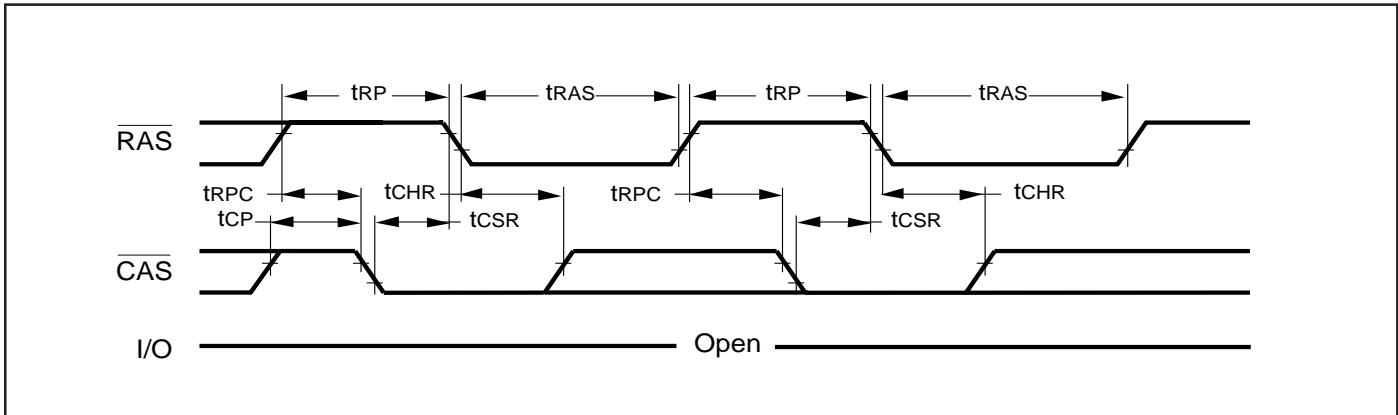

HIDDEN REFRESH CYCLE⁽¹⁾ (\overline{WE} = HIGH; \overline{OE} = LOW)

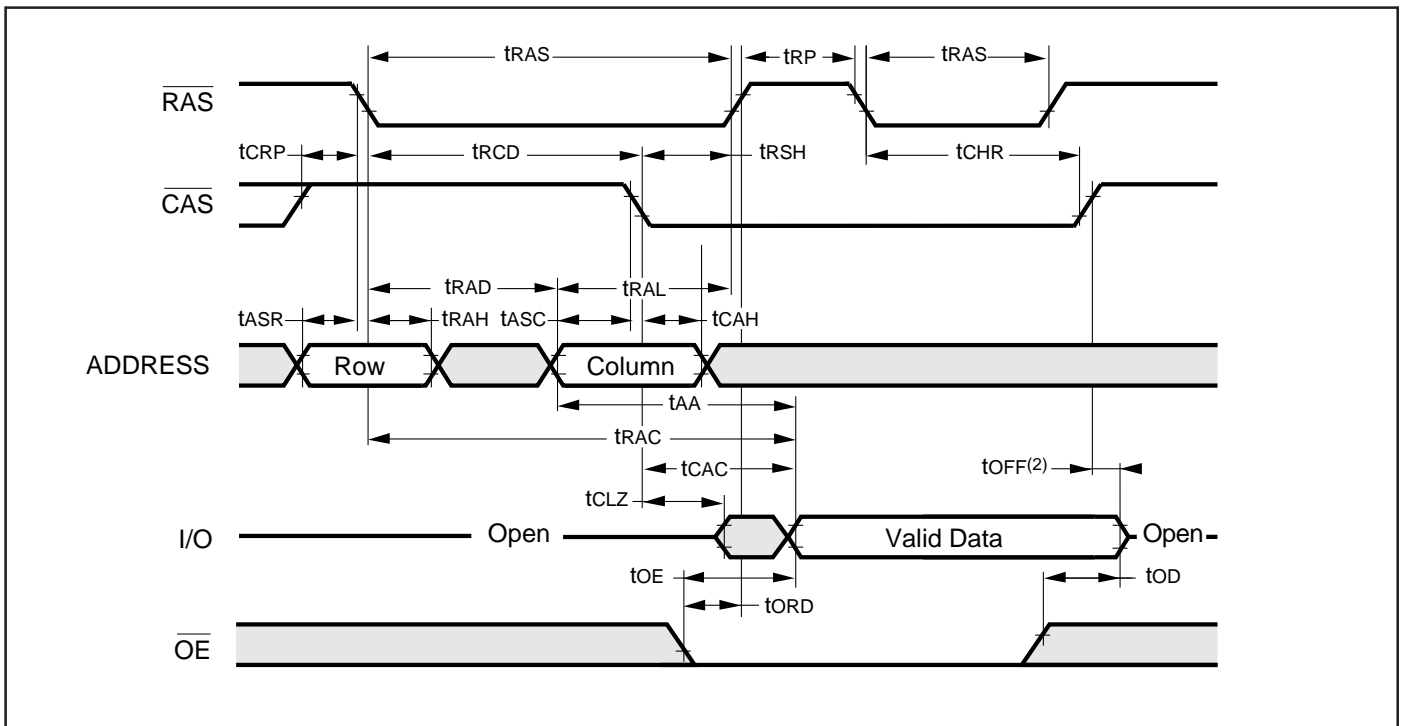

Notes:

1. A Hidden Refresh may also be performed after a Write Cycle. In this case, \overline{WE} = LOW and \overline{OE} = HIGH.
2. toff is referenced from rising edge of RAS or CAS, whichever occurs last.

SELF REFRESH CYCLE (Addresses : \overline{WE} and \overline{OE} = DON'T CARE)

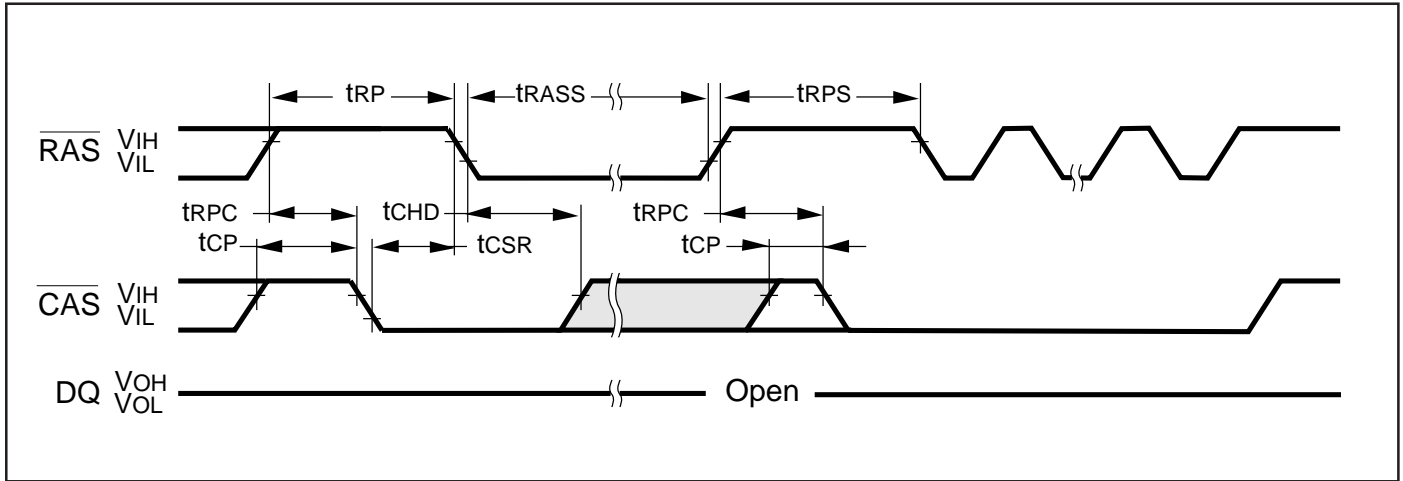

TIMING PARAMETERS

Symbol	-50		-60		Units
	Min.	Max.	Min.	Max.	
tCHD	10	—	10	—	ns
tCP	9	—	9	—	ns
tCSR	10	—	10	—	ns
tRASS	100	—	100	—	μs
tRP	30	—	40	—	ns
tRPS	84	—	104	—	ns
tRPC	5	—	5	—	ns

ORDERING INFORMATION

Commercial Range: 0°C to 70°C

Voltage: 5V

Speed (ns)	Order Part No.	Refresh	Package
50	IC41C44002A-50J	2K	300mil SOJ
50	IC41C44002A-50T	2K	300mil TSOP-2
60	IC41C44002A-60J	2K	300-mil SOJ
60	IC41C44002A-60T	2K	300mil TSOP-2

Speed (ns)	Order Part No.	Refresh	Package
50	IC41C44002AS-50J	2K	300mil SOJ
50	IC41C44002AS-50T	2K	300mil TSOP-2
50	IC41C44002ASL-50J	2K	300mil SOJ
50	IC41C44002ASL-50T	2K	300mil TSOP-2
60	IC41C44002AS-60J	2K	300mil SOJ
60	IC41C44002AS-60T	2K	300mil TSOP-2
60	IC41C44002ASL-60J	2K	300mil SOJ
60	IC41C44002ASL-60T	2K	300mil TSOP-2

Voltage: 3.3V

Speed (ns)	Order Part No.	Refresh	Package
50	IC41LV44002A-50J	2K	300mil SOJ
50	IC41LV44002A-50T	2K	300mil TSOP-2
60	IC41LV44002A-60J	2K	300mil SOJ
60	IC41LV44002A-60T	2K	300mil TSOP-2

Speed (ns)	Order Part No.	Refresh	Package
50	IC41LV44002AS-50J	2K	300mil SOJ
50	IC41LV44002AS-50T	2K	300mil TSOP-2
50	IC41LV44002ASL-50J	2K	300mil SOJ
50	IC41LV44002ASL-50T	2K	300mil TSOP-2
60	IC41LV44002AS-60J	2K	300mil SOJ
60	IC41LV44002AS-60T	2K	300mil TSOP-2
60	IC41LV44002ASL-60J	2K	300mil SOJ
60	IC41LV44002ASL-60T	2K	300mil TSOP-2



Integrated Circuit Solution Inc.

HEADQUARTER:
NO.2, TECHNOLOGY RD. V, SCIENCE-BASED INDUSTRIAL PARK,
HSIN-CHU, TAIWAN, R.O.C.

TEL: 886-3-5780333

Fax: 886-3-5783000

BRANCH OFFICE:
7F, NO. 106, SEC. 1, HSIN-TAI 5TH ROAD,
HSICHIH TAIPEI COUNTY, TAIWAN, R.O.C.

TEL: 886-2-26962140

FAX: 886-2-26962252

<http://www.icsi.com.tw>