



商用冷藏柜 / 冷冻柜

COMMERCIAL REFRIGERATOR/FREEZER

使用说明书 INSTRUCTION MANUAL



HRE/HFE-127B-_HD

- 使用说明书是本产品不可分割的重要组成部分，用户须妥善保管。
- 请务必仔细阅读本使用说明书中描述的指南和警告事项，因为这些指南和警告事项为安装人员/用户提供了正确安装、持续安全地使用和保养本产品所需的重要信息。
- 请妥善保管本使用说明书，以便必要时参考使用。
- This booklet is an integral and essential part of the product and should be kept and preserved by the user.
- Please read carefully the guidelines and warnings contained herein as they are intended to provide the installer/user with essential information for the proper installation and the continued safe use and maintenance of the product.
- Please preserve this booklet for any further consultation that may be necessary.

生产商：**星崎电机(苏州)有限公司**
Manufacturer: **HOSHIZAKI (SUZHOU) CO., LTD.**

HRE-67B- * HD-_
HRE-77B- * HD-_
HRE-77B- * LD-_
HRE-127B- * HD-_
HRE-127B- * LD-_
HRE-147B- * HD-_
HRE-147B- * LD-_
HRE-187B- * HD-_
HRE-187B- * LD-_
HRE-70B- * HD-_
HRE-70B- * LD-_
HRE-140B- * HD-_
HRE-140B- * LD-_
HFE-67B- * HD-_
HFE-77B- * HD-_
HFE-77B- * LD-_
HFE-127B- * HD-_
HFE-127B- * LD-_
HFE-147B- * HD-_
HFE-147B- * LD-_
HFE-187B- * HD-_
HFE-187B- * LD-_
HFE-70B- * HD-_
HFE-70B- * LD-_
HFE-140B- * HD-_
HFE-140B- * LD-_
HRFE-77B- * HD-_
HRFE-77B-WR-_
* : C, S, T, A
_ : GN, ML

L1R27330B (071018)

中文

- I. 一般信息1
 - 1. 结构(HRE-147B-CHD/SHD/THD)1
 - 2. 附件1
 - 3. 安装位置1
 - 4. 安装2
 - 5. 层板和导轨3
 - [a] 层板和层板托(标准)3
 - [b] 导轨(定制)3
 - [c] 支撑杆(定制)4
 - 6. 电气连接4
 - 7. 排水管连接4
- II. 操作说明5
 - 1. 启动5
 - 2. 前板5
 - 3. 柜内温度设置6
 - 4. 框架加热器6
 - 5. 除霜6
 - 6. 关机7
- III. 保养和清洁说明7
 - 1. 内部、外部、层板7
 - 2. 空气过滤网7
- IV. 报修前8
 - 1. 显示故障代码的故障8
 - 2. 不显示故障代码的故障8
- V. 废弃处理8
- VI. 保修9

ENGLISH

- I. INSTALLATION INSTRUCTIONS10
 - 1. CONSTRUCTION (HRE-147B-CHD/SHD/THD)10
 - 2. ACCESSORIES10
 - 3. LOCATION10
 - 4. SET UP11
 - 5. SHELF AND RAIL12
 - [a] SHELF AND SHELF CLIP (standard)12
 - [b] RAIL (customized)12
 - [c] HANGER (customized)13
 - 6. ELECTRICAL CONNECTIONS13
 - 7. DRAIN CONNECTIONS13
- II. OPERATING INSTRUCTIONS14
 - 1. START UP14
 - 2. FRONT PANEL15
 - 3. CABINET TEMPERATURE SETTING15
 - 4. FRAME HEATER16
 - 5. DEFROST16
 - 6. SHUT DOWN16
- III. MAINTENANCE16
 - 1. INTERIOR, EXTERIOR, SHELF16
 - 2. AIR FILTER17
- IV. BEFORE CALLING A SERVICE AGENT17
 - 1. TROUBLES WITH ERROR CODE INDICATION17
 - 2. TROUBLES WITHOUT ERROR CODE INDICATION18
- V. DISPOSAL18
- VI. WARRANTY18

警告



请勿弄湿本产品或在潮湿环境下使用本产品。否则可能会导致漏电，进而造成触电或火灾。

保持干燥

重要

1. 本冷藏柜/冷冻柜为商用设备，仅适用于该设备所指定的设计用途。用于任何其它用途将被认为使用不当，并且将非常危险。对因本产品使用不当、使用不正确和不合理而引发的任何后果，生产厂家恕不承担责任。
2. 本产品不适合残障、智障及缺乏相应经验和知识的人士(包括儿童)单独使用，除非有专人负责其安全，并对其使用本产品加以监督和指导。另外还应对年幼儿童加以看管，以确保其不玩耍本产品。

I. 一般信息

1. 结构(HRE-147B-CHD/SHD/THD)



图 1

2. 附件

宽度	700mm	1200/1400mm	1800mm
a) 层板:	4 [4]	8 [8]	12 [12]
b) 层板托:	16 [16]	32 [32]	48 [48]
	16 [16] (HRFE机型)		
c) 层板支架:	4 [0]	8 [0]	12 [0]
	8 [0] (HRFE机型)		
d) 扳手:	1 [1]	1 [1]	1 [1]
	(仅限带脚轮的机型)		
e) 隔垫:	4 [4]	4 [4]	6 [6]
	(仅限带脚轮的机型)		

注：1. 中括号中的数值适用于无层板支架的机型。
2. 定制产品的附件可能会与上述不同。

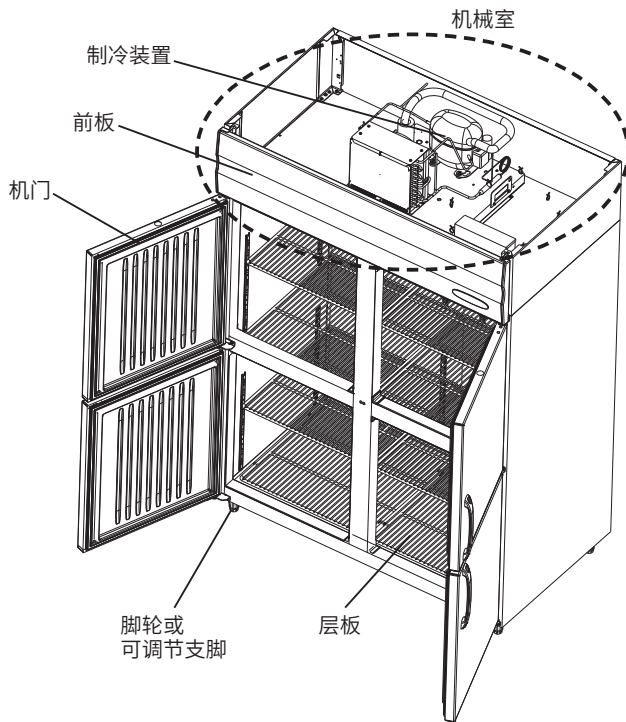
3. 安装位置

重要

本冷藏柜/冷冻柜仅供室内使用。正常的工作环境温度应在5°C至43°C的范围内。

为了获得最佳性能:

- * 请勿将冷藏柜/冷冻柜安装在炉子、烤架或其他会产生高温的设备附近。
- * 安装位置应坚实，足以承受设备重量。
- * 避免将其安装在不允许出现滴落的场所。尤其当采用并排或背靠背安装方式(可以与其他制造商的产品一起安装)时，由于两台机器之间可能会出现冷凝，因此冷凝水会滴落到地板上。
- * 请勿将本机暴露在直射阳光或高温下。
- * 本机前方至少应留出100cm的空间，以便能够顺利地开关机门。同时，本机上方至少应具有30cm的空间，以确保空气流通顺畅。



图 2

* 请使用下列防倾倒套件(选购件)固定四个支腿，以防止本机倾倒：

[防倾倒套件]

可调节支腿(4Y2042-01, 选购件)	4
防震支腿(454440-01, 选购件)	4
防震接头(454441-01, 选购件)	4
地脚螺栓M10(不提供)	4

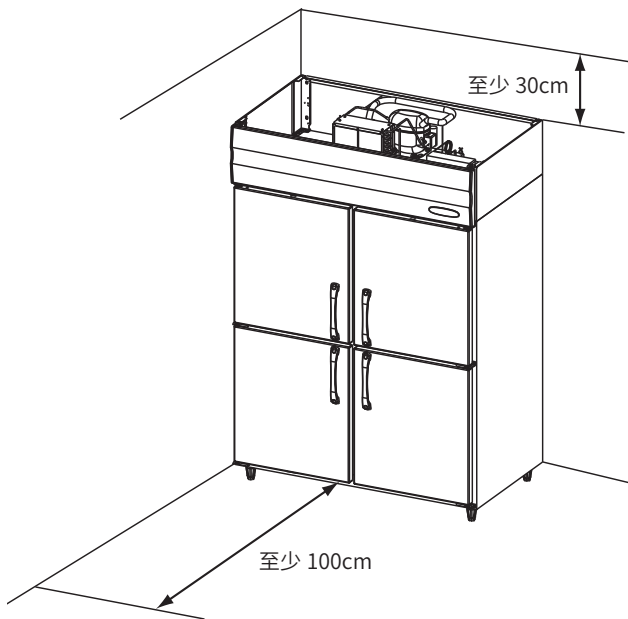
[安装示例]

- 1) 使用选购的可调节支腿更换脚轮/可调节支腿。
- 2) 将支腿的可调节端更换为防震支腿。
- 3) 将两个后部防震接头安装至地板。
- 4) 将冷藏柜/冷冻柜安装至固定好的防震接头。
- 5) 安装前部防震接头。

* 调节接头的位置和方向，以便优化地脚螺栓的功能。

* 使用防震支腿会导致高度提高约5mm。

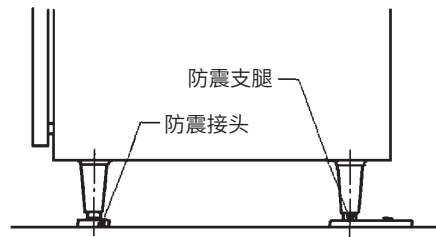

侧视图

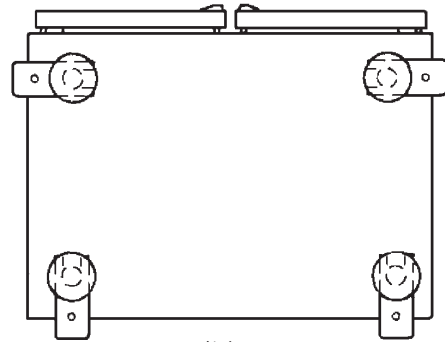

仰视图

图 3

4. 安装

重要

1. 安装支腿或脚轮时，请勿倾斜本机超过45°。
2. 搬运本机时，请握住其底部。
3. 请将库内所有物品清空后再进行冰箱位置的移动。

- 1) 割断乙烯基装运胶带，拆开纸箱。
- 2) 取出层板和层板托这两个附件。
将四个层板托水平安装至层板立柱。将层板搁在层板托上。
- 3) 使用本机前，请拆下所有装运纸箱、包装、胶带和本机外表面上的保护塑料膜。请小心不要损坏外部的面板。
- 4) 将本机置于所选的安装位置。
- 5) 将软布浸泡在由冷水或温水加适量中性清洁剂混合而成的溶液中，然后取出软布并拧干，再使用该软布清洁本机内部。

[带脚轮的机型]

- 6) 调节冷藏柜/冷冻柜的高度，使其在左右和前后方向保持水平。若要调节本机的高度，请将隔垫(附件)插入脚轮接头。使用扳手(附件)拧松或拧紧脚轮。调平本机后，请将脚轮拧紧。锁止前部脚轮的止动器。



图 4

[带可调节支腿的机型]

6) 冷藏柜/冷冻柜应在左右和前后方向保持水平。若要调节本机的高度，请转动可调节支腿的调节器。

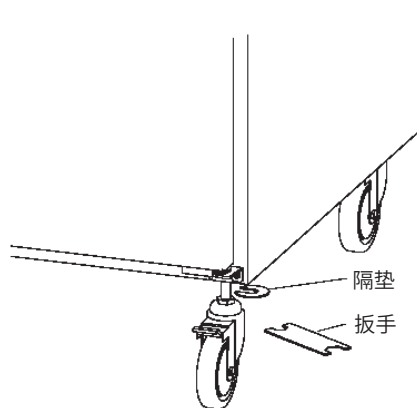

图 5

注意

可调节支腿的高度必须为9~12(或15~18) cm。如果过度伸长，可能会减弱支腿强度，或者导致调节器脱落，造成意外的人身伤害。

5. 层板和导轨

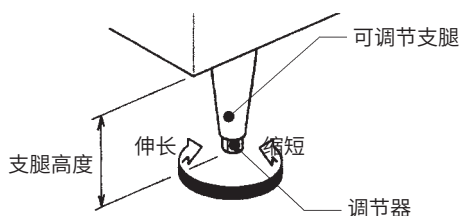
[a] 层板和层板托(标准)

- * 层板高度可以2.5cm高度单位进行调节。请根据存放的物品的高度调节层板托。
- * 若要安装层板托，请将上部凸片插入层板立柱中的调节孔以钩住层板托，然后将下部凸片推入另一个调节孔，直至其锁止到位。若要拆下层板托，请按照相反的步骤进行操作。



图 6

注意

请正确安装层板托，以保持层板水平。

* 如下图所示，若要将层板放于柜体的底部，请在左右边柜处分别安装两个层板支架。

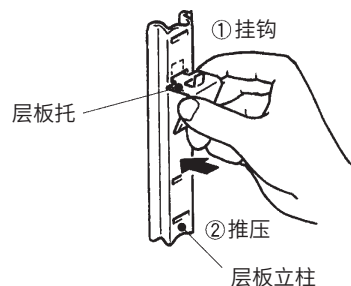

图 7

重要

请勿在柜体底部放置任何物品，以防止柜体底部受损或变形，从而导致腐蚀。

[b] 导轨(定制)

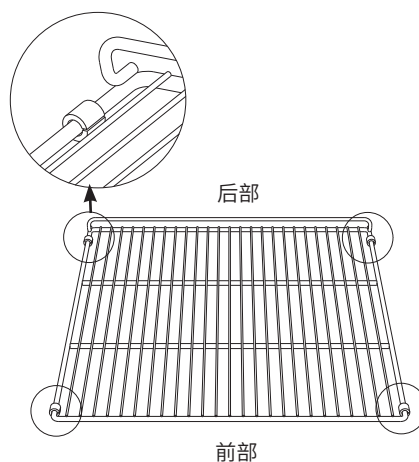
- * 若要安装导轨，(1)请将导轨挂钩向后推入后层板立柱上的方孔，(2)然后将导轨挂钩向下推入前层板立柱上的方孔。若要拆下导轨，请按照与上述相反的步骤操作。详见图8。

注意

请正确安装层板托，以保持层板水平。



图 8

[c] 支撑杆(定制)

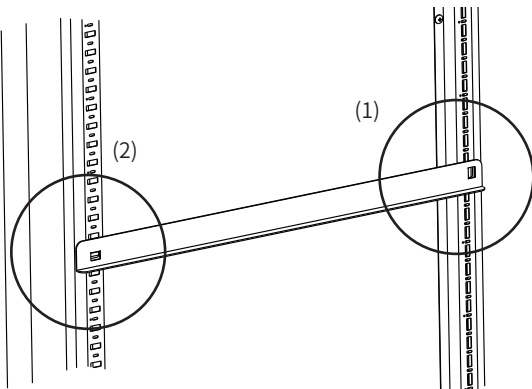
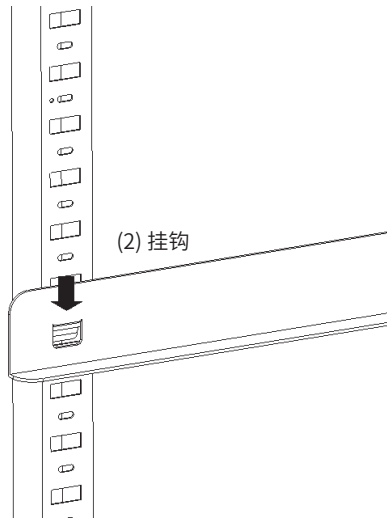
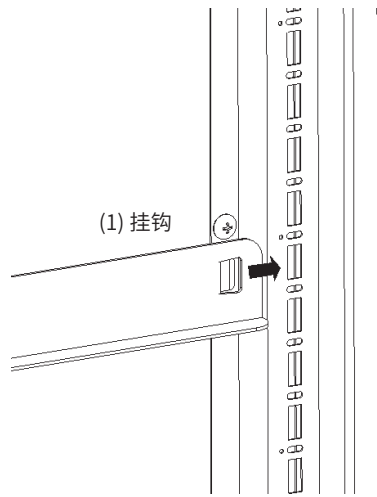

图 9

6. 电气连接

重要

本冷藏柜/冷冻柜未配备电源开关或接地漏电断路器，而只配备过电流保护装置。请在主电源上安装一个不小于15A的、防止过载的接地漏电断路器。

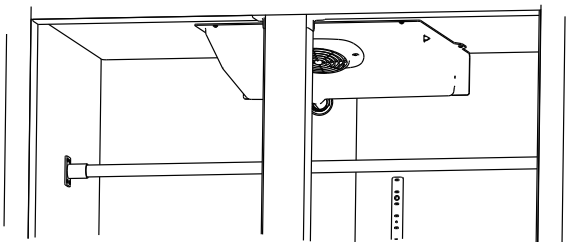
- * 本冷藏柜/冷冻柜的插头必须插入单独的电源插座，且该插座必须方便插拔且具有足够的容量。允许的最大电压波动不得超过铭牌额定电压的±10%。请参见铭牌。
- * 如需更换电源线和插头，务必联系合格的维修工程师来开展这项工作，以免发生危险。

7. 排水管连接

小心

请务必切实连接好排水软管。否则，排水软管可能漏水，并破坏周围环境。

重要

1. 排水管路应尽量短而直，且应保证有足够的坡度及落差，以确保管路高度始终低于排水口。
2. 为防止废水回流，请勿将排水软管直接连至下水道系统。请在排水软管的末端与排水水位间至少留出5cm的空隙。

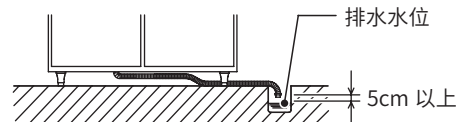

3. 当安装2台以上的机器时，请勿将排水软管连在一起。如果需要连接在一起，请在每台机器间留出足够的空隙。

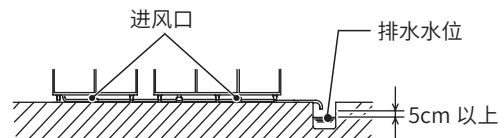

- * 排水口位于柜体的底部。请使用附件连接排水软管。
 - * HRFE机型配备2个除霜排水口，而HRE和HFE机型仅配备一个除霜排水口。
- 1) 请将挠性软管一端(直径18mm)插入除霜排水口中，再用附带的排水软管卡箍固定挠性软管。
 - 2) 将挠性软管的另一端(外径26mm)连接到下水道系统处。



图 10

* 强制排水蒸汽机型(定制)未配备排水口。排水在机体后侧内部蒸发。

II. 操作说明

重要

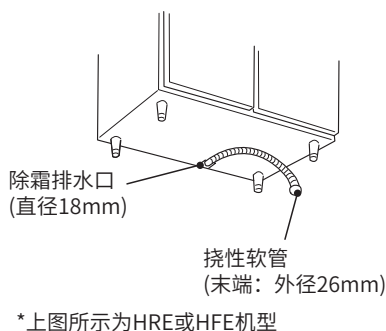
1. 请不要弄湿制冷机械室。否则可能会导致本机故障或触电。
2. 为防止触电，请勿用湿手触摸连接插头。
3. 请勿在本机中存放易挥发或易燃物品，如汽油、乙醚、粘合剂和LPG。
4. 本冷藏柜/冷冻柜的设计用途是临时存放食物。将其用于任何其它用途(例如存放疫苗、血清等化学或医学用品)可能会导致存放的物品变质。
5. 请勿将物品抛掷到层板上或者在单块层板上放置60kg以上的物品。否则层板可能会掉落并导致受伤。
6. 请勿在出风口处存放玻璃瓶或易拉罐。否则，瓶罐中的液体可能会结冰和破裂，进而导致受伤。
7. 请勿在本机附近使用可燃喷雾剂或放置易挥发物品和易燃物品。否则，操作开关或类似装置时产生的火花可能会导致这些物品起火。
8. 请勿在机械室内或进风口/出风口处放置任何物品。内部高速旋转的风扇可能会造成人员受伤或产生高温。
9. 在柜内放置食物前，请使冷藏柜/冷冻柜通电1小时，并检查温度是否正常。
10. 请勿将食物放置在阻挡进风口/出风口的位置。
11. 请勿在柜内塞满食物。请在食物与食物之间留出适当空间，以确保空气流通顺畅。

12. 请勿放入温热或滚烫的食物。请首先让食物自然冷却，否则会导致柜内温度上升，从而可能会造成柜内存放的其它食物变质或导致冷藏柜/冷冻柜过载。
13. 确保所有物品在各个层板上摆放有序。
14. 潮湿或新鲜的食物以及海鲜等具有强烈气味的食物应使用保鲜膜包裹或存放在容器中。否则，这些食物可能会变干或使得其它食物串味。
15. 含有醋酸或酵母的食物应使用保鲜膜包裹。否则，这些食物可能会加速蒸发器和铜管的腐蚀，进而导致故障。
16. 直接食用的食物应放置在合适的容器内，并且避免与柜壁直接接触。
17. 请勿使用冷冻柜来冷冻食物。冷冻柜仅用来存放冷冻好的食物。除霜过程中，高品质冰激凌可能会融化，因此不应将其存放在冷冻柜中。
18. 柜门刚关闭时难以立即打开，因为此时柜内会产生负压。请等待约30秒。

1. 启动

- 1) 插入本机插头。
- 2) 压缩机和冷凝器风扇马达将在3分钟内启动。

2. 前板

打开和关闭前板：

朝前拉前板，以便将其从底部的夹持器上松开，然后如图所示将前板向上翻。

要关闭前板，请将底部两侧切实卡入夹持器中。



图 11

拆下前板:

将底部两侧从夹持器上松开，然后将其垂直提起。

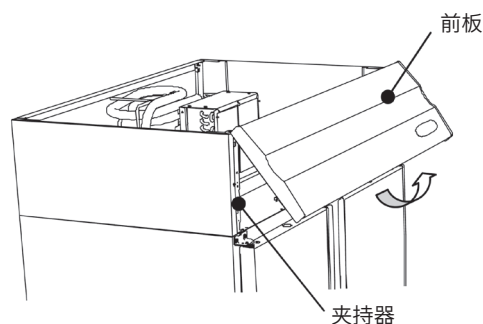

图 12

3. 柜内温度设置

注意

1. 按温度控制按钮(向下)只能降低温度设定值，并不会起到加快制冷速度的作用。
2. 下文中的温度范围仅指可调节范围。柜内的实际温度取决于环境温度和其它条件。

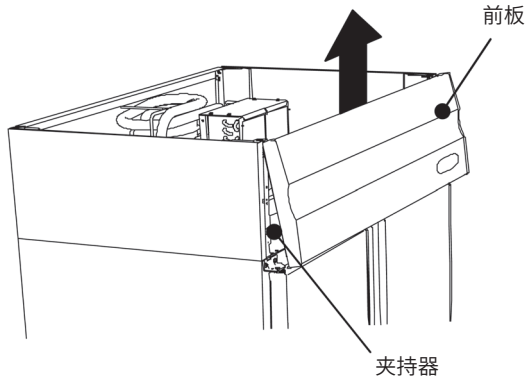
柜内温度在出厂时设为3°C(用作冷藏柜时)和-18°C(用作冷冻柜时)。如果需要，请按照如下方法重新调节温度:

- 1) 打开前板。
- 2) 按设置点按钮以显示当前设置点温度。
- 3) 按住设置点按钮，并按温度控制按钮，直至温度显示窗口显示所需的温度。可以在-0°C和16°C之间(或-6°C和12°C之间)以及-25°C和-7°C之间(用作冷冻柜时)调节柜内温度。
- 4) 显示的柜内温度会被调节为与未放置食物时柜内中心处的温度近似的温度。但是，根据存放的食物、机门开启频率或测量点不同，这一温度可能与实际温度有所不同。

HRE, HFE

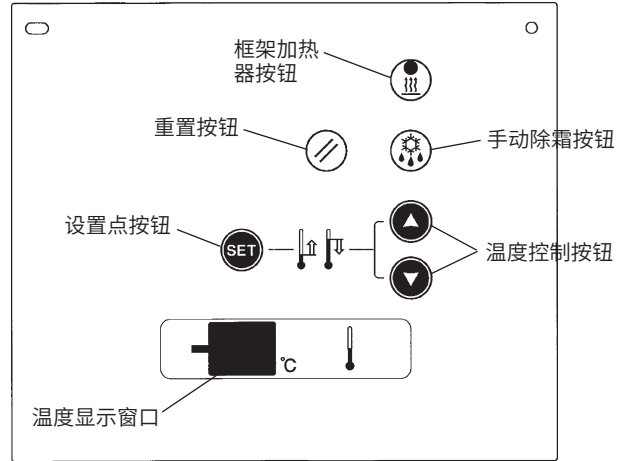

HRFE



图 13

4. 框架加热器

前部框架配有内置加热器，用来防止冷凝。该加热器的出厂设置为“低温”。如果前部框架上出现冷凝水，则可以将框架加热器调节至“高温”。

按住操作面板上的框架加热器按钮3秒以上。此时，指示灯会亮起，且框架加热器将被调节至“高温”。

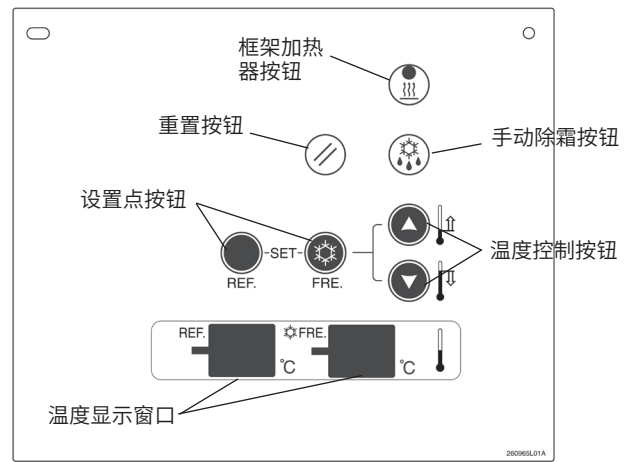
若要将设置更改为“低温”，请按住框架加热器按钮3秒以上。此时，指示灯将熄灭，且框架加热器将被设置为“低温”。

5. 除霜

冷藏柜/冷冻柜会每隔6个小时自动对蒸发器除霜。用作冷藏柜时，温度显示窗口会在除霜过程中交替显示柜内温度和“dF”。用作冷冻柜时，温度显示窗口会在除霜过程中显示“dF”。

若要启动手动除霜过程，请按住手动除霜按钮5秒以上。下一次除霜过程将在6个小时内开始。

6. 关机

- 1) 关机前，请将存放的食物移至另一台冷藏柜/冷冻柜。
- 2) 拔下插头或断开主电源。
- 3) 长时间不使用机器时，请清洁柜内部和机门衬垫，并将它们彻底晾干，然后将机器保管在干燥场所。

III. 保养和清洁说明

重要

1. 开展清洁或保养操作前，请拔下本机插头。
2. 请勿触摸或弄湿制冷装置室零件。否则可能会导致本机故障或损坏。
3. 请勿将塑料零件放入温度超过40°C的水中或洗碗机中清洗，以免损坏零件。

1. 内部、外部、层板

- * 为保持冷藏柜/冷冻柜清洁，至少每隔一星期清洁冷藏柜/冷冻柜内部和外部。如需移动本机，请解锁脚轮。[带脚轮的机型]
- * 将软布浸泡在由冷水或温水加适量中性清洁剂混合而成的溶液中，然后取出软布并拧干，再使用该软布清洁本机内部和外部。请勿用喷水器清洁机械室。
- * 使用中性清洁剂以外的化学试剂可能会导致内表面和外表面损坏。
- * 任何洗涤剂残留都将损伤金属或塑料表面，因此请使用蘸有温水的软布将其擦除。



图 14

- * 请勿使用下列物品，以免其损坏喷漆或塑料表面：抛光粉、酒精、稀释剂、挥发油、酸性或碱性洗涤剂、热水、石油精、肥皂粉、金属打磨工具或刷子等。尤其不可使用专用于清除通风设备或微波炉上油脂的洗涤剂。

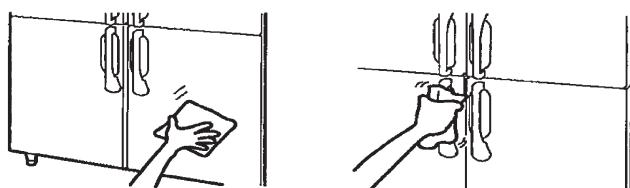

图 15

注：上述以外的洗涤剂也有可能损伤涂装保护面及塑料表面。
出现异常时请立即停止使用。

- * 柜门衬垫及其接触表面很容易变脏，请彻底清洁这些部位。否则，食物残渣会加速这些部位的老化。
- * 用抹布擦去柜内的积水。

2. 空气过滤网

重要

为防止空气过滤网变形，请勿使用40°C以上的水清洗空气过滤网。

该空气过滤网可以清除空气中的污垢或灰尘，防止冷凝器堵塞。
如果过滤器堵塞，冷藏柜/冷冻柜的制冷性能将下降。至少每月检查过滤器两次。如果过滤器堵塞，请使用温水和中性清洁剂进行清洗。请勿在空气过滤网已拆下的情况下使用本机，否则会导致冷凝器堵塞，进而造成本机故障。

- 1) 打开前板并拆下空气过滤网。请勿直接触摸冷凝器的翅片，以免受伤。



图 16

- 2) 使用含有适量中性清洁剂的冷水或温水小心地清洗空气过滤网。冲洗并彻底晾干空气过滤网。

3) 若要重新安装空气过滤网, 请将其安装到冷凝器顶部的导板上, 再插入制冷机组基座的插槽中。

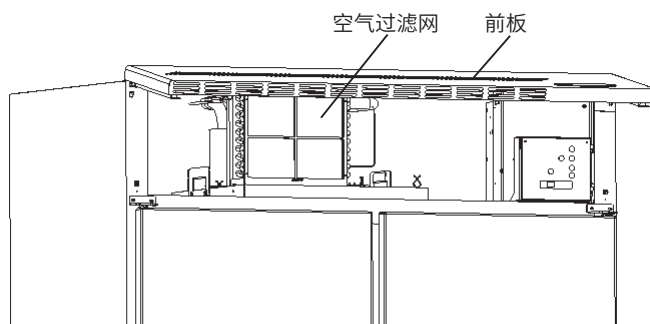

图 17

IV. 报修前

重要

1. 如果操作面板上的显示屏显示故障代码或本机存在故障迹象, 请根据以下说明查找可能的故障原因。如果故障仍然存在, 请立即联系授权的星崎维修公司。
2. 联系维修公司时, 请向对方说明型号、序列号、安装日期(参见保修卡)以及故障状况。
3. 请勿尝试自行维修本机。

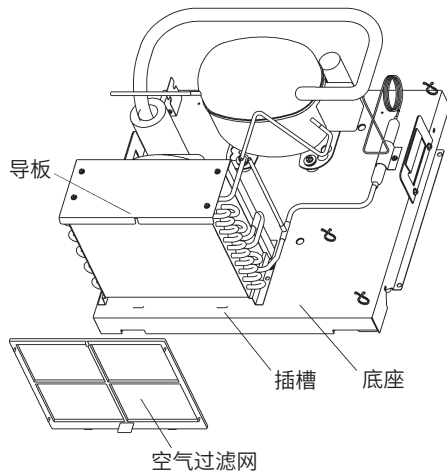
1. 显示故障代码的故障

代码	故障及可能的原因
E1	柜内温度过高。 (1) 环境温度过高(43°C以上)。 (2) 柜内存放了温热或滚烫的食物。 (3) 机门打开。
E2	柜内温度过低。 (1) 环境温度过低(5°C以下)。 (2) 冷冻食物正在解冻。
E3	除霜故障。立即联系授权的星崎维修公司。
E4, E7	空气过滤网堵塞。 (1) 环境温度过高(43°C以上)。 (2) 空气过滤网变脏。
E5, E8, E9	热敏电阻故障。立即联系授权的星崎维修公司。
EA, Eb, Ed	电脑板故障。立即联系授权的星崎维修公司。
EE	与压缩机有关的故障。立即联系授权的星崎维修公司。

* 若要取消故障代码显示:

如果某个代码不停闪烁, 请打开前板, 并按操作面板上的重置按钮。(代码“E7”、“E8”、“E9”、“EA”、“Eb”和“Ed”无法取消。)

如果多个代码不停闪烁, 按重置按钮会取消优先级最高的第一个代码, 然后再次按该按钮取消其他代码。

故障代码将按照如下优先级顺序显示:

EA > Ed > EE > E5 > E8 > E9 > E4 > E7 > E3 > E1 > E2

* “dF”代码并非故障代码, 而是表示本机正处于除霜过程中。

2. 不显示故障代码的故障

- 1) 本机无法运转:
 - (1) 未插电源插头。
 - (2) 停电。
 - (3) 主电源断开。
- 2) 制冷性能不佳:
 - (1) 环境温度过高(43°C以上)。
 - (2) 频繁打开柜门。
 - (3) 柜内温度设定过高。
 - (4) 食物放入过多。
 - (5) 空气过滤网脏污。
 - (6) 柜门未关闭。
- 3) 柜门附近出现冷凝水:
 - (1) 环境湿度过高。
 - (2) 框架加热器按钮设定为“低”(指示灯熄灭)。
 - (3) 柜门未关紧。
- 4) 噪声:
 - (1) 压缩机或冷凝器风扇的正常运转声。
- 5) 机械室内部结霜:
 - (1) 环境湿度过高。
 - (2) 频繁打开柜门。
 - (3) 食物放入过多, 超出了机器的负荷。

V. 废弃处理

对冷藏柜/冷冻柜进行废弃处理时, 请联系授权的星崎维修公司或专门的废品处理公司。

重要



用于机体的隔热材料发泡剂含有易燃气体环戊烷。请记住这一点, 正确处置冷藏柜/冷冻柜。

VI. 保修

星崎向拥有者/用户保证，星崎品牌的所有产品在产品“保修期”内不存在材料和/或工艺缺陷。产品保修在自产品安装之日起一年内有效。

星崎在此保修条款下承担有限责任，但日常维护、清洁、必需的保养和/或因误用以及未根据星崎的准则安装而导致的修理除外。

保修范围内的维修应由授权的星崎经销商或维修机构负责，且应使用纯正的星崎零件。

若要获取有关保修和授权维修机构的详细信息，请联系经销商/供货商或最近的星崎维修办事处。

生产许可证号：
XK06-015-02299

制品标准番号：
GB 4706.1
SB 10424
GB/T 21001.2 (玻璃门机型)
GB/T 21001.3 (玻璃门机型)
JB/T 7244 (不锈钢门机型)

安全注意事项

有毒有害物质元素分析

商用制冰机、商用冰箱、商用电磁烹饪机、商用啤酒机的环保标识和产品中心非环保类物质或元素的名称及含量的说明

1. 产品中心非环保类物质或元素的名称及含量：

部件名称	对象机种(型号)	非环保类物质或元素					
		铅及其化合物	汞及其化合物	镉及其化合物	六价铬及其化合物	多溴联苯及其化合物	多溴二苯醚及其化合物
		(Pb)	(Hg)	(Cd)	(Cr(VI))	(PBB)	(PBDE)
填充阀	制冰机全型号、冰箱全型号、啤酒机	×	○	○	○	○	○
拨动开关	制冰机 (KMD-270AA;KMD-270AWA)	×	○	×	○	○	○
电源线	啤酒机 (DBF-40SAC;DBF-25SAC)	×	○	○	○	○	○
供电板	冰箱 (HRE-*B;HFE-*B;HRFE-*B)	×	○	○	○	○	○
风扇马达	冰箱 (HRE-*B;HFE-*B;HRFE-*B) 电磁烹饪机 (HIH-*YA)	×	○	○	○	○	○
开关稳压器	冰箱 (RTC-S*A;FTC-S*A)	×	○	○	○	○	○
水量调节阀	制冰机 (KMD-*AWA;IM-220AWA)	×	○	○	○	○	○
把手	电磁烹饪机 (HIH-*YA)	×	○	○	○	○	○
膨胀阀	制冰机 (IM-220A*A)	×	○	○	○	○	○

○：表示该有害物质在该部件所有均质材料中的含量均在GB/T 26572规定的限量要求以下。

×：表示该有害物质至少在该部件的某一均质材料中的含量超出GB/T 26572规定的限量要求。

注：本产品的部件均采用无毒无害的绿色环保材料制造，所含有的非环保类物质或元素皆由于全球的技术和工艺水平限制而无法实现非环保类物质或元素的完全替代，但本产品中非环保类物质或元素的含量极其微小，长期使用不会对人体产生危害，请放心使用。

2. 环保标识的说明：



本产品根据国家法规《电器电子产品有害物质限制使用管理办法》的相关规定，采用了行业标准《SJ/T 11364 电子电气产品有害物质限制使用标识要求》中电子电器产品有害物质控制标志。

3. 废弃电子电器产品回收处理说明：

为了更好的关爱及保护地球，当用户不再需要此产品或产品寿命终止时，请遵守国家废弃电子电器产品回收处理相关法律法规，将其交给当地具有国家认可的回收处理资质的厂商进行回收处理。

型号别能效标识参数

规格型号		有效容积	总能量消耗	温度分级	冷柜类型	能效等级
RTC-120MNA	RT-126MA	231	2.84	M1	VC5	3
RTC-120MDA	RT-128MA	307	2.75	M1	VC5	3
RTC-150MNA	RT-156MA	318	3.07	M1	VC5	4
RTC-150MDA	RT-158MA	420	3.01	M1	VC5	3
RTC-180MNA	RT-186MA	401	3.55	M1	VC5	5
RTC-180MDA	RT-188MA	502	3.94	M1	VC5	4
FTC-120MNA	FT-126MA	231	5.99	L1	VF5	4
FTC-120MDA	FT-128MA	307	6.18	L1	VF5	3
FTC-150MNA	FT-156MA	318	7.62	L1	VF5	4
FTC-150MDA	FT-158MA	420	5.78	L1	VF5	1
FTC-180MNA	FT-186MA	401	6.88	L1	VF5	3
FTC-180MDA	FT-188MA	502	8.32	L1	VF5	3
RTC-90SNA		143	1.99	M1	VC5	2
RTC-90SDA		190	1.98	M1	VC5	2
RTC-120SNA		228	2.51	M1	VC5	3
RTC-120SDA		301	2.72	M1	VC5	3
RTC-150SNA		313	3.00	M1	VC5	4
RTC-150SDA		413	2.93	M1	VC5	3
RTC-180SNA		398	3.39	M1	VC5	4
RTC-180SDA		502	3.42	M1	VC5	3
FTC-90SNA		143	5.19	L1	VF5	4
FTC-90SDA		190	5.53	L1	VF5	4
FTC-120SNA		228	5.79	L1	VF5	3
FTC-120SDA		301	6.16	L1	VF5	3
FTC-150SNA		313	6.34	L1	VF5	3
FTC-150SDA		413	8.17	L1	VF5	3
FTC-180SNA		398	8.07	L1	VF5	3
FTC-180SDA		502	8.86	L1	VF5	3
HRE-77MA-CHD	HR-78MA	546	3.29	M1	VC5	3
HRE-127MA-CHD	HR-128MA	1110	5.15	M1	VC5	3
HRE-147MA-CHD	HR-148MA	1217	4.90	M1	VC5	3
HRE-187MA-CHD	HR-188MA	1600	5.50	M1	VC5	3
HFE-77MA-CHD	HF-78MA	546	8.71	L1	VF5	3
HFE-127MA-CHD	HF-128MA	1100	14.14	L1	VF5	3
HFE-147MA-CHD	HF-148MA	1203	13.36	L3	VF5	3
HFE-187MA-CHD	HF-188MA	1600	16.09	L1	VF5	2
HRE-77B-CHD		547	3.02	M1	VC5	2
HRE-127B-CHD		1109	3.93	M1	VC5	2
HRE-147B-CHD		1218	4.79	M1	VC5	3
HRE-187B-CHD		1600	5.48	M1	VC5	3
HFE-77B-CHD		546	7.40	L1	VF5	2
HFE-127B-CHD		1102	10.17	L1	VF5	1
HFE-147B-CHD		1205	12.03	L1	VF5	1
HFE-187B-CHD		1600	14.10	L1	VF5	1
HRFE-77MA-CHD	HRF-78MA	260/ 280	8.42	M1 L1	VC5 VF5	4
HRFE-127MAF-CHD	HRF-128MA	454/ 454	12.05	M1 L1	VC5 VF5	5
HRFE-147MAF-CHD	HRF-148MA	550/ 550	11.38	M1 L1	VC5 VF5	3
HRFE-187MAF-CHD	HRF-188MA	1025/ 498	12.40	M1 L1	VC5 VF5	4
HRFE-77B-CHD		0.299/ 0.243	8.48	M1 L1	VC5 VF5	4

标识参考图样：



注：特注机采用标准机标签。



WARNING

Do not wet this product or use it in potentially wet conditions. This may cause electric leakage, resulting in electric shock or fire.

IMPORTANT

1. This is a commercial refrigerator/freezer, and should be destined only to be used for the purpose for which it has been expressly designed. Any other use should be considered improper and therefore dangerous. The manufacturer will not be held liable or responsible for any damage caused by improper, incorrect and unreasonable use.
2. This appliance is not intended for use by persons (including children) with reduced physical, sensory or mental capabilities, or lack of experience and knowledge, unless they have been given supervision or instruction concerning use of the appliance by a person responsible for their safety. Young children should be supervised to ensure that they do not play with the appliance.

2. ACCESSORIES

Width	700mm	1200/1400mm	1800mm
a) Shelf:	4 [4]	8 [8]	12 [12]
b) Shelf clip:	16 [16]	32 [32]	48 [48]
	16 [16] (HRFE)		
c) Shelf holder:	4 [0]	8 [0]	12 [0]
	8 [0] (HRFE)		
d) Spanner:	1 [1]	1 [1]	1 [1]
	(caster model only)		
e) Spacer:	4 [4]	4 [4]	6 [6]
	(caster model only)		

- Note: 1. Numbers in parentheses are for models without shelf holders.
2. Customized products may have different numbers and specifications of accessories.

3. LOCATION

IMPORTANT

This refrigerator/freezer is not intended for outdoor use. Normal operating ambient temperature should be within 5°C to 43°C.

I. INSTALLATION INSTRUCTIONS

1. CONSTRUCTION (HRE-147B-CHD/SHD/THD)

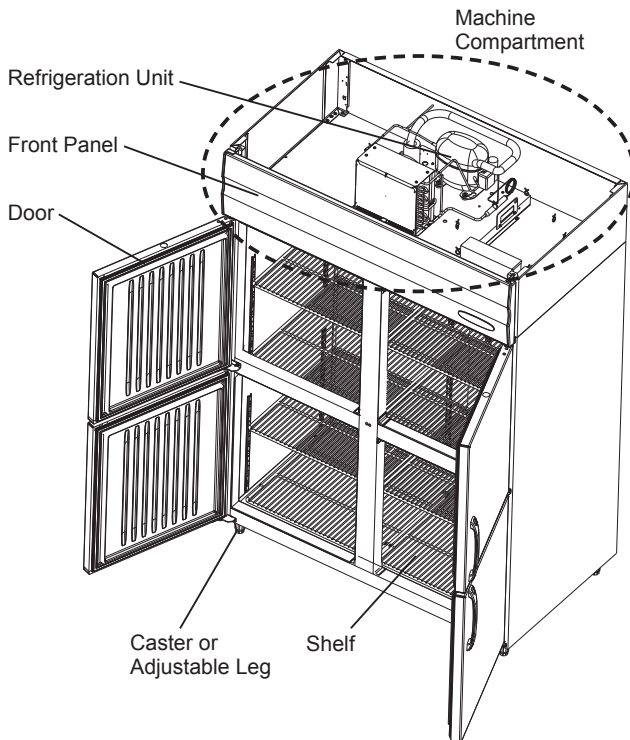

Fig. 1

For best operating results:

- * The refrigerator/freezer should not be located next to ovens, grills or other high heat producing equipment.
- * The location should provide a firm foundation for the equipment.
- * Avoid a site where dripping is not allowed. Especially, a side-by-side or back-to-back installation (possibly with other manufacturer's unit) may cause condensation between the two units, resulting in dripping onto the floor.
- * Do not expose the unit to direct sunlight or higher temperatures.
- * Allow at least 100 cm clearance at the front of the unit for smooth door operation. Also allow at least 30 cm clearance from the ceiling to the top of the unit for proper air circulation.

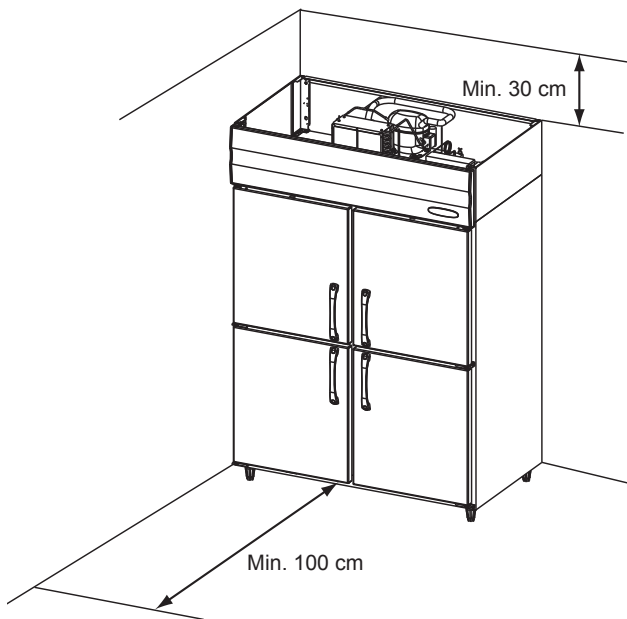
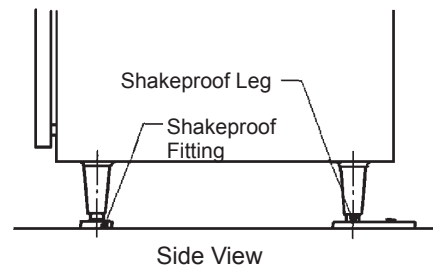
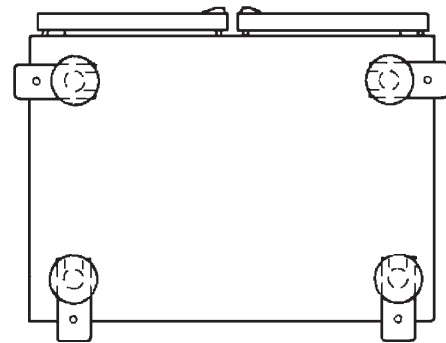

Fig. 2



Side View



Bottom View

Fig. 3

* Protect the unit from tipping over by fixing the four legs with the following tip-resistant kit (optional):

[Tip-resistant kit]

Adjustable leg (4Y2042-01, optional)	4
Shakeproof leg (454440-01, optional)	4
Shakeproof fitting (454441-01, optional)	4
Anchor bolt M10 (not provided)	4

[Installation example]

- 1) Replace the casters/adjustable legs with the optional adjustable legs.
- 2) Replace the adjustable ends of the legs with the shakeproof legs.
- 3) Fix the two rear shakeproof fittings to the floor.
- 4) Mount the refrigerator/freezer on the fixed shakeproof fittings.
- 5) Fix the front shakeproof fittings.

- * Locate and orient the fittings to optimize the function of the anchor bolts.
- * The shakeproof legs will raise the height by about 5 mm.

4. SET UP

IMPORTANT

1. Do not tilt the unit more than 45° when mounting the legs or casters.
2. Carry the unit by holding its bottom.
3. Remove all stuff inside the cabinet before moving the unit.

- 1) Cut the vinyl shipping tape and remove the carton.
- 2) Take out the accessory shelves and shelf clips. Attach the four shelf clips horizontally to the shelf posts. Place the shelf on the shelf clips.
- 3) Before operating the unit, remove all shipping carton, packing, tape(s) and protective plastic film on the exterior. Be careful not to damage the exterior panels.
- 4) Position the unit in a selected site.
- 5) Clean the interior with a soft cloth soaked in cold or warm water containing the proper amount of neutral cleaner and wrung dry.

[Caster models]

- 6) Level the refrigerator/freezer in both the left-to-right and the front-to-rear directions. To adjust the height of the unit, insert the spacers (accessory)

ENGLISH

into the caster joints. Use the spanner (accessory) to loosen or tighten the casters. After making the unit level, tighten the casters securely. Lock the stoppers of the front casters.

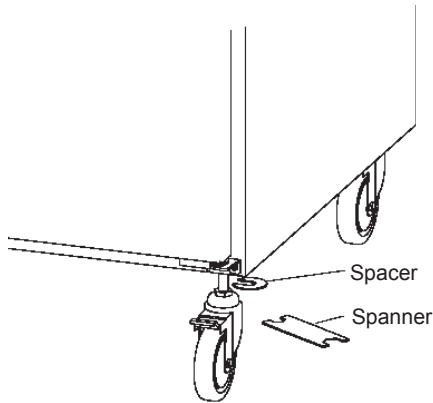

Fig. 4

[Adjustable leg models]

6) Level the refrigerator/freezer in both the left-to-right and the front-to-rear directions. To adjust the height of the unit, turn the adjusters of the adjustable legs.

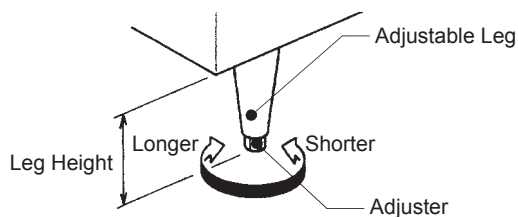

Fig. 5

CAUTION

The height of the adjustable legs must be within 9 - 12 cm (or 15 - 18). If extended too much, the legs may become weak or the adjusters can come off, causing unexpected injuries.

5. SHELF AND RAIL

[a] SHELF AND SHELF CLIP (standard)

* The shelf is adjustable in 2.5 cm increments. Adjust the shelf clips according to the height of stored items.

* To attach the shelf clip, insert the upper tab into an adjust hole in the shelf post to hook the shelf clip, and push the lower tab into another adjust hole until it locks in place. To detach the shelf clip, reverse the above procedure.

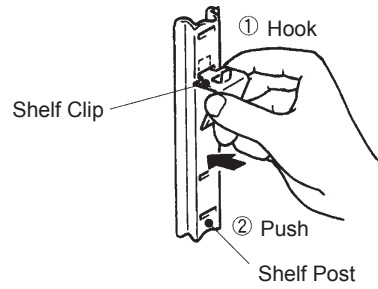

Fig. 6

CAUTION

Attach the shelf clips properly to make the shelf level.

* To lay the shelf at the bottom of the cabinet, attach two shelf holders each to the left and right frames as shown below.

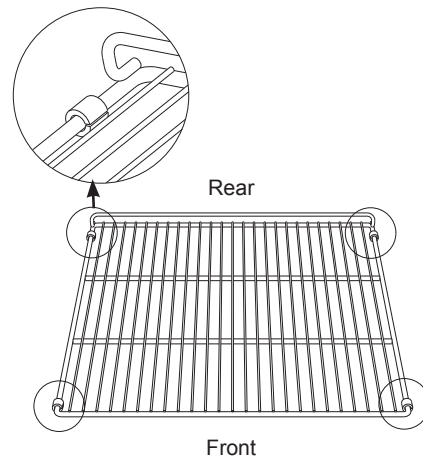

Fig. 7

IMPORTANT

Do not put anything at the bottom of the cabinet to prevent damage or deformation to the cabinet bottom, resulting in corrosion.

[b] RAIL (customized)

* To attach the rail, (1) push the rail hook backwards to fit into the square hole in the rear shelf post, and (2) push the rail hook down to fit into the square hole in the front shelf post. To detach the rail, reverse the above procedure. See Fig. 8.

CAUTION

Attach the rail properly to make it level.

6. ELECTRICAL CONNECTIONS

IMPORTANT

This refrigerator/freezer is provided with no power switch or earth leakage circuit breaker, but with overcurrent protection only. Install an earth leakage circuit breaker with overload protection rated at least 15A on the main power supply.

- * This refrigerator/freezer must be plugged into the separated power receptacle which is readily accessible and has enough capacity. The maximum allowable voltage variation should not exceed ± 10 percent of the nameplate rating. See the nameplate.
- * If the supply cord and the plug should need to be replaced, it should only be done by a qualified service engineer to avoid any danger.

7. DRAIN CONNECTIONS

CAUTION

Be sure to connect the drain hoses properly. Otherwise water leaks from the drain hoses may damage the surroundings (property).

IMPORTANT

1. Drain lines shall be as short and straight as possible. The drain hoses shall have an adequate pitch and fall so that no part is higher than the drain outlets.
2. To prevent a backflow, do not connect the drain hoses directly with the sewer system. An air gap of a minimum of 5 cm should be between the ends of the drain hoses and the water level of drainage.

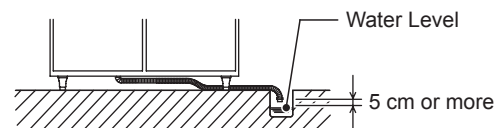

3. When installing more than two units, do not interconnect their drain hoses. If the interconnection is necessary, provide an air inlet per unit.

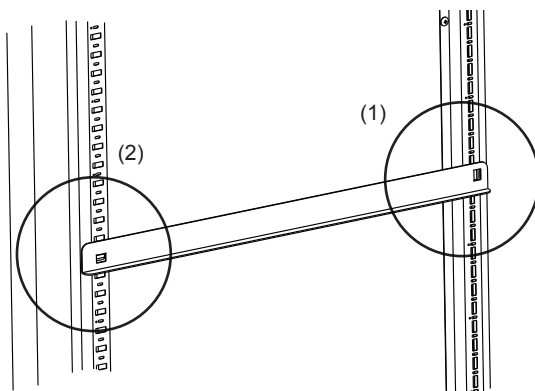
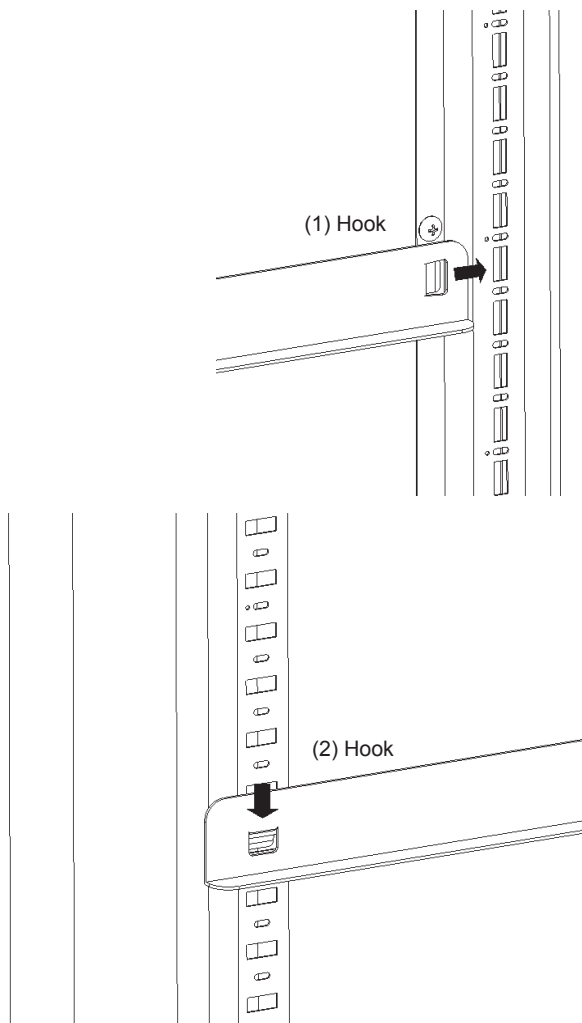
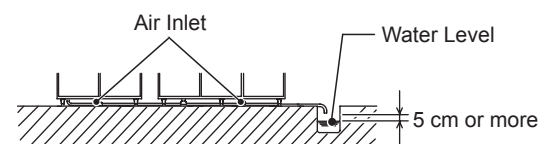

Fig. 8

[c] HANGER (customized)

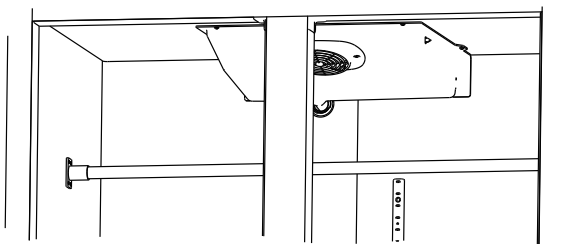
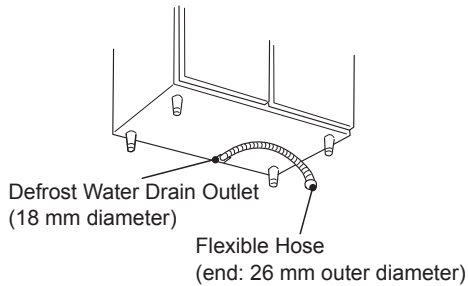

Fig. 9

ENGLISH

- * The drain outlets are at the bottom of the body. Use the accessories to connect the drain hoses.
 - * HRFE type is provided with two defrost water drain outlets while HRE and HFE types are provided with only one.
- 1) Insert the 18 mm diameter end of flexible hose into the defrost water drain outlet, and fix the flexible hose with the accessory drain hose band.
 - 2) Attach the other end (26 mm outer diameter) of the flexible hose to the drainage.



* The illustration above shows HRE or HFE

Fig. 10

- * The drain outlet is not provided for forced drain water evaporation model (customized). Drain water is evaporated inside the rear side of the body.

II. OPERATING INSTRUCTIONS

IMPORTANT

1. Be careful not to wet the machine compartment. This might cause failure or electric shock hazard.
2. To prevent electric shock, do not touch the attachment plug with wet hands.
3. Do not store any volatile or flammable substances, such as benzene, ether, adhesives and LPG, in the unit.
4. This refrigerator/freezer is designed only for temporary storage of foods. Use for any other purposes (e.g. storage of chemicals or medical supplies such as vaccine and serum) could cause deterioration of stored items.
5. Do not throw anything onto the shelves or load more than 60 kg on each of them. They may fall off and cause injury.
6. Do not store bottles or cans near the air outlet. They may freeze up and break, causing a risk of injury.

7. Do not use combustible spray or place volatile and flammable substances near the unit. They could catch fire from a spark of a switch or the like.
8. Do not put anything into the machine compartment or the air inlet/outlet. The fan rotating rapidly inside may cause injury or heat.
9. Energise the refrigerator/freezer for 1 hour and check for proper temperature before putting foods in the cabinet.
10. Do not block the air inlet/outlet with foods.
11. Do not pack the cabinet with foods. Allow some space between them to ensure good air flow.
12. Do not put in warm or hot foods. Let them cool first, or they will raise the cabinet temperature and could deteriorate other foods in the cabinet or overload the refrigerator/freezer.
13. Make sure all items are snug on each shelf.
14. Moist or fresh foods and those with a strong smell like seafood should be wrapped up in a plastic film or packed in a container. Otherwise the foods may dry up or give their smells to other foods.
15. Foods containing acetic acid or yeast should be wrapped up in a plastic film. Otherwise they may accelerate corrosion of the evaporator and copper tubes, resulting in failure.
16. Foods intended for direct human consumption should be stored on the shelf in a proper container and protected from direct contact with the cabinet walls.
17. Do not use the freezer to freeze foods. It is designed only to store frozen foods. High quality ice cream may melt during defrost cycle and should not be stored in the freezer.
18. The doors may become difficult to open just after closed because of the negative pressure created inside the cabinet. Wait for about 30 seconds.

1. START UP

- 1) Plug in the unit.

2) The compressor and condenser fan motor will start in 3 minutes.

2. FRONT PANEL

To open and close the front panel:

Pull each side of the front panel toward you to release it from the grip on each side of the bottom, and swing up the front panel as shown. To close the front panel, fit both sides of the bottom securely in the grips.

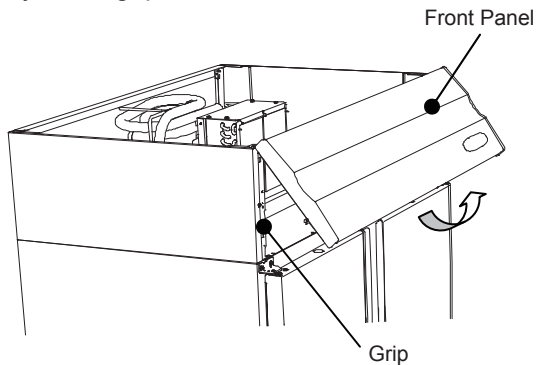

Fig. 11

To remove the front panel:

Release both sides of the bottom from the grips, and lift it off vertically.

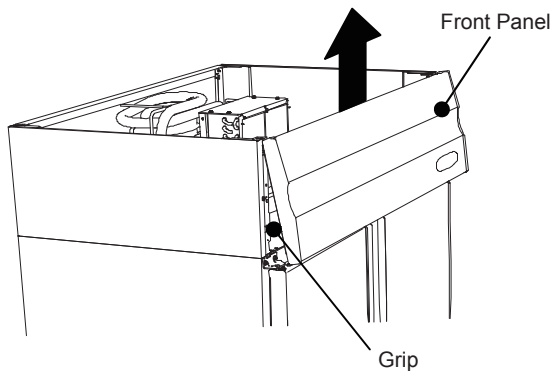

Fig. 12

3. CABINET TEMPERATURE SETTING

IMPORTANT

1. Pressing the temperature control button (downward) will not speed up refrigeration, but will only lower the temperature setting.
2. The temperature range given below is only the adjustable range. The actual cabinet temperature depends on the ambient temperature and other conditions.

The cabinet temperature is factory-adjusted to 3°C for the refrigerator and -18°C for the freezer. If necessary, readjust the temperature as follows:

- 1) Open the front panel.
- 2) Press the set point button to display the current set point temperature.
- 3) Press and hold the set point button, and push the temperature control button until the temperature display window shows the desired temperature. The cabinet temperature is adjustable between -0°C and 16°C (or -6°C and 12°C) for the refrigerator and between -25°C and -7°C for the freezer.
- 4) The displayed cabinet temperature is adjusted to be almost equal to the temperature at the center of the cabinet without foods. But it can be different from the actual temperature depending on arrangement of stored foods, frequency of door opening or measuring points.

HRE, HFE

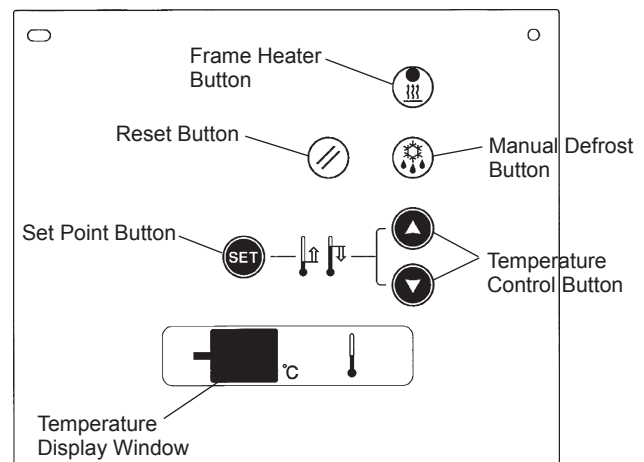

HRFE

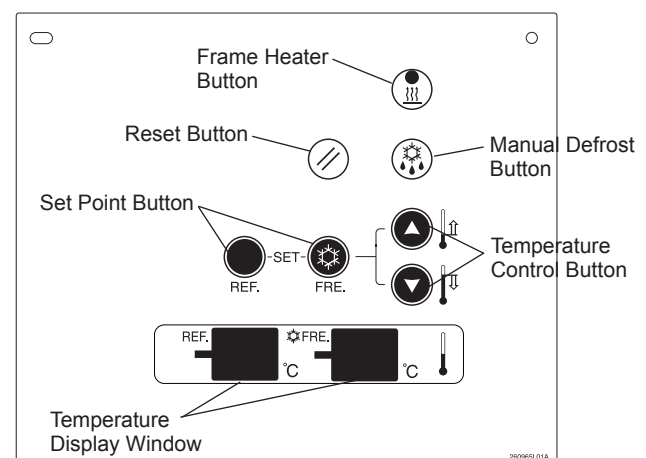

Fig. 13

ENGLISH

4. FRAME HEATER

The front frame is provided with a built-in heater to prevent condensation. It is factory-adjusted to "low". If condensation forms on the front frame, the frame heater can be adjusted to "high".

Press the frame heater button on the operation panel for more than 3 seconds. The lamp will illuminate and the frame heater will be adjusted to "high".

To change the setting to "low", press the frame heater button for more than 3 seconds. The lamp will go out and the frame heater will be set to "low".

5. DEFROST

The refrigerator/freezer automatically defrosts the evaporator every 6 hours. For the refrigerator, the temperature display window shows the cabinet temperature and "dF" alternately during defrost cycle. For the freezer, the temperature display window shows "dF" during defrost cycle.

To start a manual defrost cycle, press the manual defrost button for more than 5 seconds. The next defrost cycle will begin in 6 hours.

6. SHUT DOWN

- 1) Before shutting down the unit, move the stored foods into another refrigerator/freezer.
- 2) Unplug the unit or disconnect the main power supply.
- 3) When preparing the unit for long storage, clean the cabinet interior and door gaskets, dry them thoroughly and store the unit in a dry place.

III. MAINTENANCE

IMPORTANT

1. Before carrying out any cleaning or maintenance operations, unplug the unit.
2. Do not touch or wet the machine compartment parts. This could result in failure or breakdown.
3. To prevent possible damage, do not clean the plastic parts with water above 40°C or in a dishwasher.

1. INTERIOR, EXTERIOR, SHELF

- * Clean the interior and exterior at least once a week for sanitary use. The unit can be moved by unlocking the casters [caster models].
- * Clean off the interior and exterior with a soft cloth soaked in cold or warm water containing the proper amount of neutral cleaner and wrung dry. Do not use a water jet to clean the machine compartment.
- * Chemical agents other than neutral cleaner might cause damage to the interior and exterior surfaces.
- * Any remaining detergent will damage metal or plastic surfaces. Use a soft cloth dampened with warm water to wipe it off.

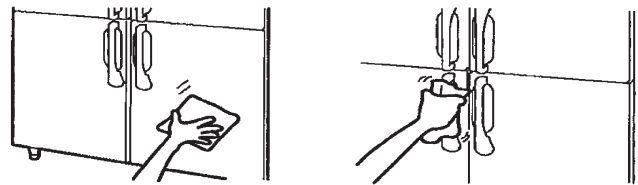

Fig. 14

- * Do not use the following items. They could damage painted or plastic surfaces:

Polishing powder, alcohol, thinner, benzine, acidic or alkaline detergent, hot water, petroleum, soap powder, metal scourer or brush, etc. Especially detergent to clean grease on ventilator or microwave.



Fig. 15

Note: Some solutions other than the above may also damage painted or plastic surfaces. Immediately stop using such solutions if they cause any problems.

- * The door gasket and its contact surface get soiled easily. Clean every surface of these parts thoroughly. Remnants of food will accelerate aging.
- * Use a cloth to wipe off any water staying inside the cabinet.

2. AIR FILTER

IMPORTANT

To prevent deformation, do not wash the air filter with hot water above 40°C.

Plastic mesh air filters remove dirt or dust from the air, and keep the condenser from getting clogged. If the filters get clogged, the refrigerator/freezer's performance will be reduced. Check the filters at least twice a month. When clogged, use warm water and a neutral cleaner to wash the filters. Do not operate the unit with the air filters removed, or the condenser will get clogged, resulting in failure.

- 1) Open the front panel and remove the air filter. To prevent injury, do not touch the condenser fins directly.

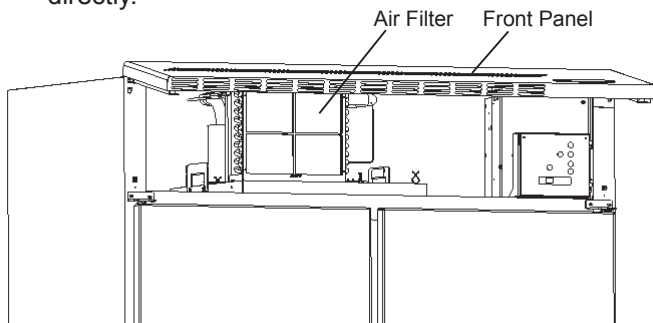

Fig. 16

- 2) Wash the air filter carefully with cold or warm water containing the proper amount of neutral cleaner. Rinse and dry the air filter thoroughly.
- 3) To refit the air filter, attach it to the guide at the top of the condenser and put the tabs into the slots in the refrigeration unit base.

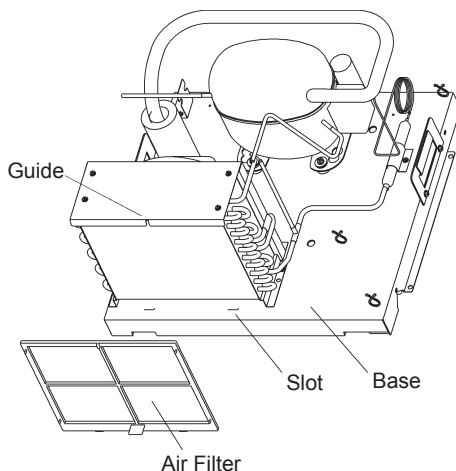

Fig. 17

IV. BEFORE CALLING A SERVICE AGENT

IMPORTANT

1. If the temperature display window on the operation panel indicates an error code or something seems wrong with the unit, check for possible causes according to the following instructions. If the problem still exists, immediately contact an authorized Hoshizaki service company.
2. When contacting a service company, let them know the model name, serial number, date of installation (see warranty card) and state of the trouble.
3. Do not attempt to repair the unit yourself.

1. TROUBLES WITH ERROR CODE INDICATION

Code	Problem and Possible Cause
E1	Cabinet temperature too high. (1) Ambient temperature too high (above 43°C). (2) Warm or hot foods inside. (3) Door(s) left open.
E2	Cabinet temperature too low. (1) Ambient temperature too low (below 5°C). (2) Frozen foods being defrosted.
E3	Defrost error. Immediately contact an authorized Hoshizaki service company.
E4, E7	Air filter clogged. (1) Ambient temperature too high (above 43°C). (2) Air filter not clean.
E5, E8, E9	Thermistor defective. Immediately contact an authorized Hoshizaki service company.
EA, Eb, Ed	Controller board defective. Immediately contact an authorized Hoshizaki service company.
EE	Compressor related error. Immediately contact an authorized Hoshizaki service company.

* To cancel the error code indication:

If only one code is flashing, open the front panel and press the reset button on the operation panel. (The codes "E7", "E8", "E9", "EA", "Eb" and "Ed" cannot be canceled.)

ENGLISH

If more than one code is flashing, press the reset button to cancel the first code in the highest priority and press it again to cancel the other code(s).

The error codes are indicated in the following order of priority:

EA > Ed > EE > E5 > E8 > E9 > E4 > E7 > E3 > E1 > E2

* The code “dF” is not an error code but indicates the unit is in defrost cycle.

2. TROUBLES WITHOUT ERROR CODE INDICATION

1) Unit fails to operate:

- (1) Unplugged.
- (2) Power failure.
- (3) Main power supply disconnected.

2) Poor cooling performance:

- (1) Ambient temperature too high (above 43°C).
- (2) Door(s) opened too often.
- (3) Cabinet temperature setting too high.
- (4) Too packed with foods.
- (5) Air filter not clean.
- (6) Door(s) left open.

3) Condensation around door(s):

- (1) Ambient humidity too high.
- (2) Frame heater button set to “low” (lamp off).
- (3) Door(s) not closed tightly.

4) Noise:

- (1) Normal operating sounds of compressor or condenser fan.

5) Frosting inside compartment:

- (1) Ambient humidity too high.
- (2) Door(s) opened too often.
- (3) Too packed with foods beyond load line.

V. DISPOSAL

When disposing of the refrigerator/freezer, contact an authorized Hoshizaki service company or a specialized waste disposal company.

IMPORTANT



The insulation foaming agent used for the unit body contains flammable gas cyclopentane. With this in mind, dispose of the refrigerator/freezer properly.

VI. WARRANTY

Hoshizaki warrants to the original owner/user that all Hoshizaki branded products shall be free of defects in material and/or workmanship for the duration of the “warranty period”. The warranty shall be effective for one year from the date of installation.

Hoshizaki’s liability under the terms of the warranty are limited and shall exclude routine servicing, cleaning, essential maintenance and/or repairs occasioned by misuse and installations not in accordance with Hoshizaki guidelines.

Warranty repairs should be completed by an approved Hoshizaki dealer or service agency using genuine Hoshizaki components.

To obtain full details of your warranty and approved service agency, please contact your dealer/supplier, or the nearest Hoshizaki Service office.

联系人:

星崎冷热机械(上海)有限公司

上海市静安区天目西路128号嘉里企业中心第一座501室

邮编: 200070

电话: +86 21 5228-8181

传真: +86 21 5228-0113



专用微信公众号

星崎香港有限公司

香港九龍觀塘巧明街95號世達中心17樓G室

电话: +852 2866-2108

传真: +852 2866-2109

Hoshizaki Singapore Pte Ltd

18 Boon Lay Way #07-142 Tradehub 21, Singapore 609966

Tel: +65 6225-2612

Fax: +65 6225-3219

台湾星崎股份有限公司

106 台北市大安區敦化南路一段337號5樓

Tel: +886 2-2706-8818

Fax: +886 2-2708-7999

Hoshizaki Lancer Pty Ltd

5 Toogood Avenue, Beverley SA 5009 Australia

Tel: +61 8-8268-1388

Fax: +61 8-8268-1978

Contact:

Hoshizaki Shanghai Co., Ltd.

Room 501, Tower 1, Kerry Enterprise Centre, 128 Tianmu Road West,
Jing'an District, Shanghai, 200070 China

Tel: +86 21 5228-8181

Fax: +86 21 5228-0113

Hoshizaki Hong Kong Co., Limited

Unit G, 17/F, World Tech Center, No. 95 How Ming Street,
Kwun Tong, Kowloon, Hong Kong

Tel: +852 2866-2108

Fax: +852 2866-2109

Hoshizaki Singapore Pte Ltd

18 Boon Lay Way #07-142 Tradehub 21, Singapore 609966

Tel: +65 6225-2612

Fax: +65 6225-3219

Hoshizaki Taiwan, Inc.

5F, No. 337, Sec. 1, Dunhua S. Rd., Da'an Dist, Taipei City 106, Taiwan (R.O.C.)

Tel: +886 2-2706-8818

Fax: +886 2-2708-7999

Hoshizaki Lancer Pty Ltd

5 Toogood Avenue, Beverley SA 5009 Australia

Tel: +61 8-8268-1388

Fax: +61 8-8268-1978

info@hoshizaki.com.au

http://www.hoshizaki.com.au



To register your product for warranty with Hoshizaki, visit
<http://www.hoshizaki.com.au/warranty-registration>
or scan the QR code.

生产商:

星崎电机(苏州)有限公司

江苏省苏州工业园区青丘街15号

邮编: 215126

电话: +86 512-62807850

传真: +86 512-62807860

Manufacturer:

HOSHIZAKI (SUZHOU) CO., LTD.

No. 15 Qingqiu Street, Suzhou Industrial Park, Suzhou 215126 China

Tel: +86 512-62807850

Fax: +86 512-62807860

HOSHIZAKI