



NTC (NO TOUCH CLEANING) OPERATOR & PARTS MANUAL

www.kaivac.com

P/N: MANUALNTC

©2017 Kaivac, Inc. All rights reserved



Denis Rawlins Ltd. 17 Maybrook, Sutton Coldfield. B76 1AL

T: 0121 351 4444 E: sales@rawlins.co.uk W: www.rawlins.co.uk

REVISION SHEET

Release No.	Date	Revision Description



OPERATOR & PARTS MANUAL - TABLE OF CONTENTS

1.0 Getting Started

1.1	PRODUCT IDENTIFICATION	5
1.2	SAFETY PRECAUTIONS:CORDED UNITS ONLY	6
1.2	SAFETY PRECAUTIONS:CORDED (CONTINUED)	7
1.3	LIMITED WARRANTY PROTECTION PLAN	8
1.3	WARRANTY REGISTRATION FORM	9

2.0 Assembly

2.1	OUT OF BOX SETUP	10
2.2	TOOL ARRANGEMENT	11
2.3	PREPARATION FOR USE	12

3.0 Maintenance

3.1	MACHINE MAINTENANCE	13
3.2	VACUUM DIAGRAM	14
3.3	PUMP DIAGRAM	15
3.4	ELECTRICAL DIAGRAM	16

4.0 Troubleshooting and Upkeep

4.1	TROUBLESHOOTING	17
4.2	TROUBLESHOOTING (CONTINUED)	18
4.3	TROUBLESHOOTING (CONTINUED)	19
4.4	TROUBLESHOOTING (CONTINUED)	20
4.5	REPLACEMENT (MONTHLY)	20

5.0 Parts Diagrams and Specifications

5.1	1200 VAC TANK ASSEMBLY	21
5.2	1200 WATER TANK ASSEMBLY	21
5.3	1200 BLACK BOX ASSEMBLY	22
5.4	1200 SWITCH PANEL ASSEMBLY	23
5.5	1200 VALVE ASSEMBLY	23
5.6	1250 PUMP ASSEMBLY	24
5.7	1200 VAC MOTOR ASSEMBLY	24
5.8	1700/17001 VAC TANK ASSEMBLY	25
5.9	1700/17001 WATER TANK ASSEMBLY	25
5.10	1750/17501 BLACK BOX ASSEMBLY	26
5.11	1700/17001 SWITCH PLATE ASSEMBLY	27
5.12	1700/17001 VALVE ASSEMBLY	27
5.13	1750/17501 PUMP ASSEMBLY	28
5.14	1700/17001 VAC MOTOR ASSEMBLY	28
5.15	27001 VAC TANK ASSEMBLY	29
5.16	27001 WATER TANK ASSEMBLY	29
5.17	27501 BLACK BOX ASSEMBLY	30
5.18	27001 HEPA ASSEMBLY	31
5.19	27001 SWITCH PLATE ASSEMBLY	31
5.20	27001 VALVE ASSEMBLY	32
5.21	27001 PUMP ASSEMBLY	32
5.21	27001 VAC MOTOR ASSEMBLY	32

1.1 PRODUCT IDENTIFICATION

Identify your system below to see the correct manual pages for your product.

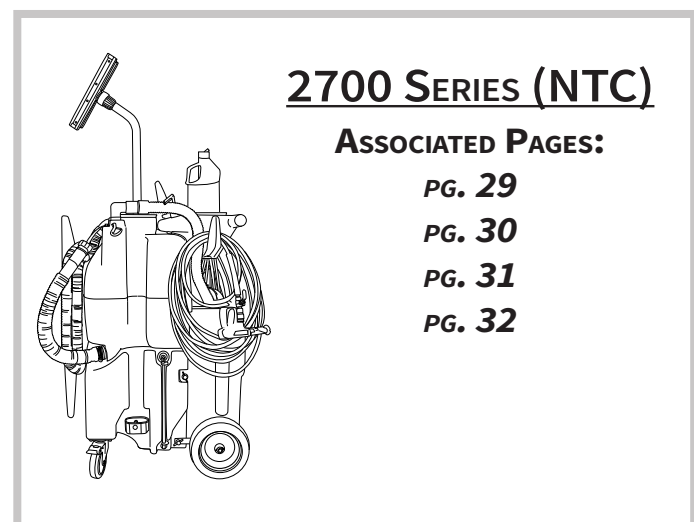
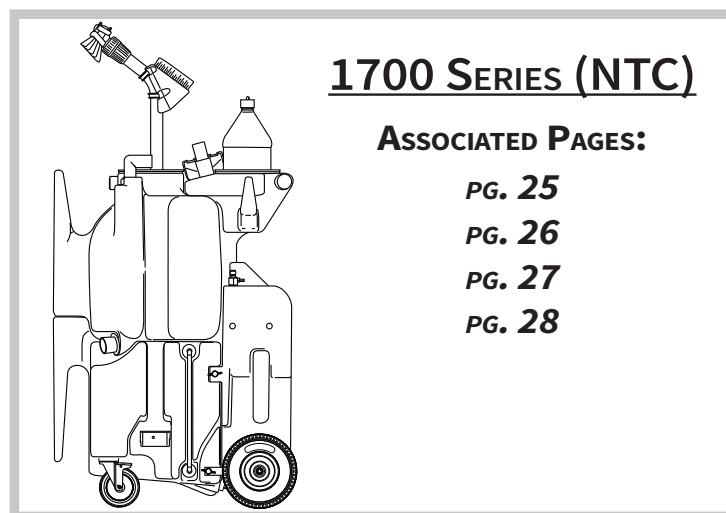
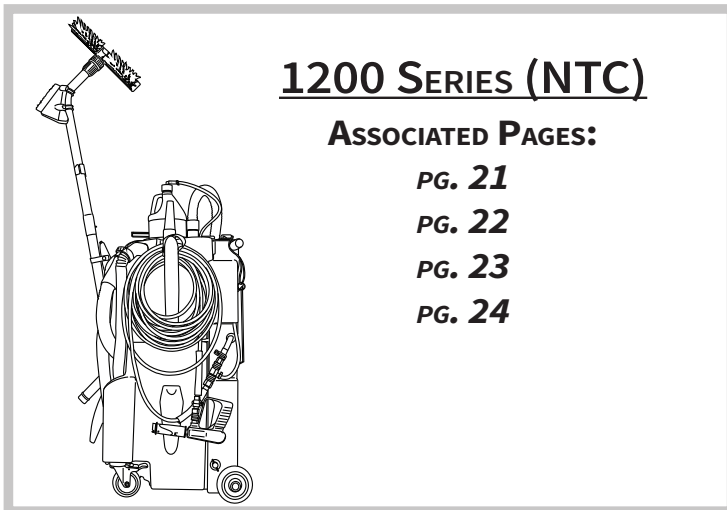

1.2 SAFETY PRECAUTIONS: CORDED UNITS ONLY

IMPORTANT SAFETY INSTRUCTIONS — SAVE THESE INSTRUCTIONS

READ ALL INSTRUCTIONS BEFORE USING (THIS APPLIANCE)

When using an electrical appliance, basic precautions should always be followed, including the following:



WARNING: To reduce the risk of fire, electric shock, or injury:

- Turn off the unit before unplugging. Do not leave appliance when plugged in. Unplug from outlet when not in use and before servicing.
- Connect to a properly grounded outlet only. Do not remove ground pin. See Grounding Instructions below.
- DO NOT allow to be used as a toy. Close attention is necessary when used by or near children.
- Use only as described in this manual. Use only manufacturer's recommended attachments.
- Inspect cord prior to use. Do not use with damaged cord or plug. If appliance is not working as it should, has been dropped, damaged, left outdoors or dropped into water, return it to a service center.
- DO NOT handle plug or appliance with wet hands.
- DO NOT pull or carry by cord, use cord as handle, close a door on cord, or pull cord around sharp edges or corners. Do not run appliance over cord. Keep cord away from heated surfaces.
- DO NOT unplug by pulling on cord. To unplug, grasp the plug, not the cord.
- DO NOT put any object into openings. Do not use with any opening blocked; keep free of dust, lint, hair, and anything that may reduce air flow.
- Keep hair, loose clothing, fingers, and all parts of body away from openings and moving parts. Turn off all controls before unplugging.
- Use extra care when cleaning on stairs.
- DO NOT use to pick up flammable or combustible liquids such as gasoline, or use in areas where they may be present.
- DO NOT pick up anything that is burning or smoking, such as cigarettes, matches or hot ashes.
- If using extension cord with appliance, make sure the connection is above the floor and away from exposure to liquid.
- Keep all connections dry and off the ground.
- To reduce the risk of injury, close supervision is necessary when a product is used near children.
- Stay alert - watch what you are doing.
- Keep operating area clear of all persons.
- The Kaivac shall be disconnected from mains during cleaning or maintenance and when replacing parts or converting the machine to another function.
- DO NOT overreach or stand on unstable support. Keep good footing and balance at all times.
- DO NOT operate without the float installed. If float is removed, reinstall by screwing back into place.
- Keep the cord away from heated surfaces.
- DO NOT use without dust bag and/or filters in place.
- This product comes with a grounded attachable extension cord. If damaged, replace with equivalent cord. This cord must be attached and mechanically secured using the provided cord connector to use the equipment.
- DO NOT operate the product when fatigued or under the influence of alcohol or drugs.
- Know how to stop the product and bleed pressures quickly. Be thoroughly familiar with the controls.
- Follow the maintenance instructions specified in the manual.

SPRAY SYSTEM WARNINGS (ONLY):

- DO NOT spray liquid from the Kaivac onto electrical outlets or any electrical devices.
- Risk of injection or injury to persons - DO NOT direct discharge stream at persons.
- INJECTION HAZARD: Equipment can cause serious injury if the spray permeates the skin. Do not point the gun at anyone or any part of the body. In case of permeation, seek medical aid immediately.
- THIS SYSTEM IS CAPABLE OF PRODUCING 500 PSI (3447 kPa). To avoid rupture and injury, do not operate this pump with components rated less than 500 PSI (3447 kPa) working pressure (including but not limited to spray guns, hose, and hose connections); and before servicing, cleaning or removal of any part, shut off power and relieve pressure.

1.2 SAFETY PRECAUTIONS:CORDED (CONTINUED)

- High pressure cleaners shall not be used by children, persons with reduced physical, sensory or mental capabilities or lack of experience and knowledge or untrained personnel. Children shall not play with the appliance. Cleaning and user maintenance shall not be made by children without supervision.
- This product may also have been provided with a ground fault circuit interrupter built into the power cord. If replacement of the plug or cord is needed, use only identical replacement parts.
- Test the ground fault circuit interrupter (GFCI) before each use.
- **Personal Protective Equipment (PPE): It is recommended to wear proper personal protective equipment as required by the chemical product label instructions used in conjunction with the appliance.**

GROUND FAULT CIRCUIT INTERRUPTER PROTECTION *(for spray systems only)*

This machine was supplied with a ground-fault circuit-interrupter(GFCI) built into the plug of the power-supply cord. This device provides additional protection from the risk of electric shock. Should replacement of the plug or cord become necessary, use only identical replacement parts that include GFCI protection.

This appliance is for use on a nominal circuit and has a grounding attachment plug. Make sure that the appliance is connected to an outlet having the same configuration as the plug. No adapter should be used with this appliance.

GROUNDING INSTRUCTIONS

This product must be grounded. If it should malfunction or breakdown, grounding provides a path of least resistance for electric current to reduce the risk of electric shock. This product is equipped with a cord having an equipment-grounding conductor and a grounding plug. The plug must be plugged into an appropriate outlet that is properly installed and grounded in accordance with all local DOE and ordinances.

WARNING

Improper connection of the equipment-grounding conductor can result in a risk of electric shock. Check with a qualified electrician or service person if you are in doubt as to whether the outlet is properly grounded. Do not modify the plug provided with the appliance – if it will not fit the outlet have a proper outlet installed by a qualified electrician.

FOR INDOOR USE ONLY

INTENDED FOR COMMERCIAL USE



WARNING — To Reduce the Risk of Electric Shock — Do not expose to rain. Store indoors.

1.3 LIMITED WARRANTY PROTECTION PLAN

The Kaivac has been engineered and tested to provide long lasting performance. This warranty covers defects in workmanship or materials under normal use and service from the date of purchase.

Kaivac, Inc. warrants the following components to be free from defects in materials and workmanship for these time periods:

1. Extended Warranty for end users who use only Kaivac chemicals for the life of the machine.
 - 5 years on rotationally molded parts
 - 3 years on other parts (excluding wear items)
 - 1 year on labor
2. Standard Warranty (for approved non-Kaivac chemicals)
 - 1 year parts and labor
3. Chemicals that have not been approved by Kaivac (If uncertain, please contact Kaivac to verify your chemical before using).
 - No warranty

All Kaivac replacement parts are guaranteed for 90 days from the date of installation. Normal wear items such as wheels, hoses, seals, gaskets, cords, casters, squeegees and GFCI are excluded from warranty coverage.

All warranty claims must be accompanied by a Return Authorization Number (RAN), which is available by calling the Kaivac, Inc. Customer Service Department. No returns will be accepted without a RAN.

This warranty does not apply to return freight costs, damage or defect caused by accident, negligence, misuse, fire or repair done by anyone other than a Kaivac authorized repair center. In no event shall Kaivac, Inc. be liable for incidental or consequential damages, or any damages to persons or property.

Please Note: Under no circumstances will the seller be liable for any loss, damage, expenses or consequential damages arising in connection with the use or inability to use seller's product. Kaivac, Inc. reserves the right to make changes or improvements to its equipment without notice. Some states do not allow the exclusion or limitation of incidental or consequential damages. This warranty is in lieu of any other warranty expressed or implied, including any warranty of merchantability or fitness for a particular purpose.

1.3 WARRANTY REGISTRATION FORM

Form must be completed and mailed or faxed by the customer purchasing equipment. Return this warranty card within ten days of purchase.

Purchased By:

Name: _____ Title: _____

Company: _____

Street Address: _____

City: _____ State: _____ Zip Code: _____

Phone Number: _____ FAX: _____

Date Purchased: ____/____/____ Where Purchased: _____

I would like to receive updated information via email Yes ____ No ____

Email Address: _____

OmniFlex

- OmniFlex Trolley-Bucket
- OmniFlex Wet Vacuum
- UniVac
- OmniFlex Dispense-and-Vac
- AutoVac
- AutoVac Battery
- OmniFlex Spray-and-Vac
- SUV

No-Touch Cleaning

- KV1250
- KV1750
- KV17501
- KV2750

Serial Number (1): _____

Serial Number (2): _____

Thank you for registering for our warranty program.

Please return completed forms to:

Kaivac, Inc.
2608 Van Hook Ave.
Hamilton, OH 45015
Or Fax to: (513) 896-8548



2.1 OUT OF BOX SETUP

Accessory Box: Open Box and remove contents. Listed below are placement instructions. Tote Bag can be removed and filled with remaining tools; set aside.

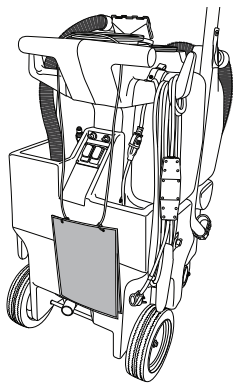
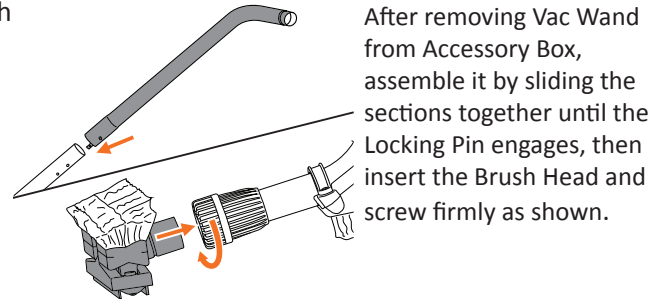
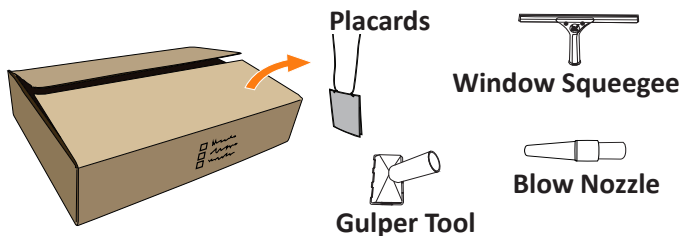

Place Placards around Push Handles of your Kaivac Machine.

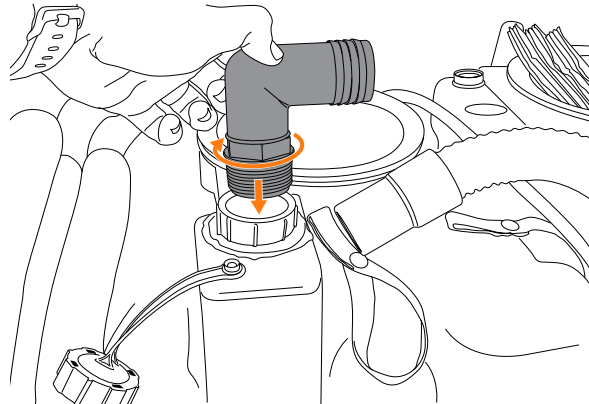

After removing the machine from the container, attach the Plastic Elbow to the Vacuum Tank as shown above.

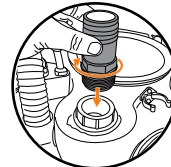

Plastic Elbow installation for KV1250 shown above.

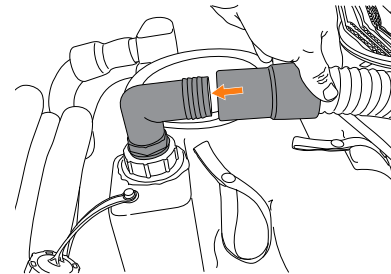

Attach Vacuum Motor Hose to Elbow.

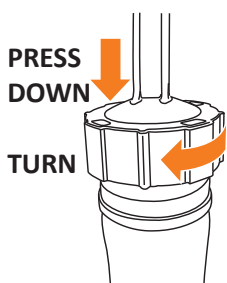

Ensure dump hose is secured to the cap-and-tether.

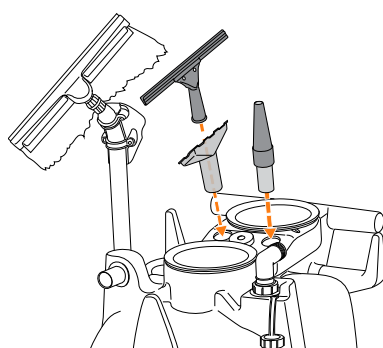

Remove Window Squeegee, KaiDrain and Blow Nozzle from Accessory Box, and place them in the appropriate locations as shown above.

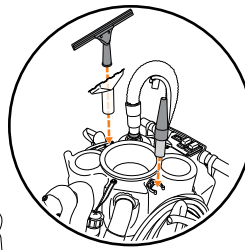

Setup for KV1250.

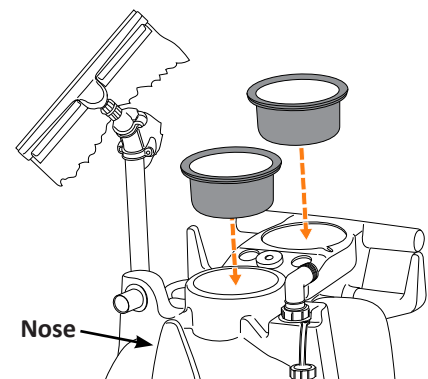

Make sure Vac Lid Jug Holders are firmly on Vacuum Tank, and place remaining tools into Tote Bag to hang on nose.

2.2 TOOL ARRANGEMENT

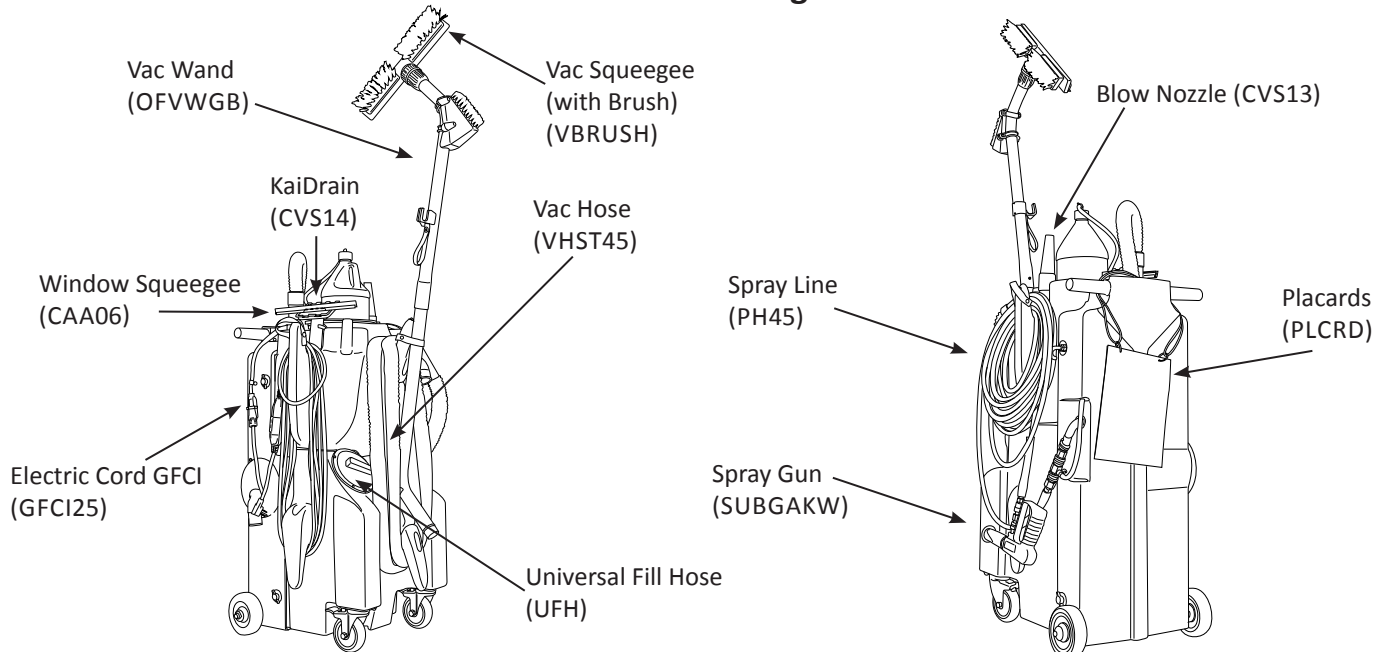

1200 Tool Arrangement

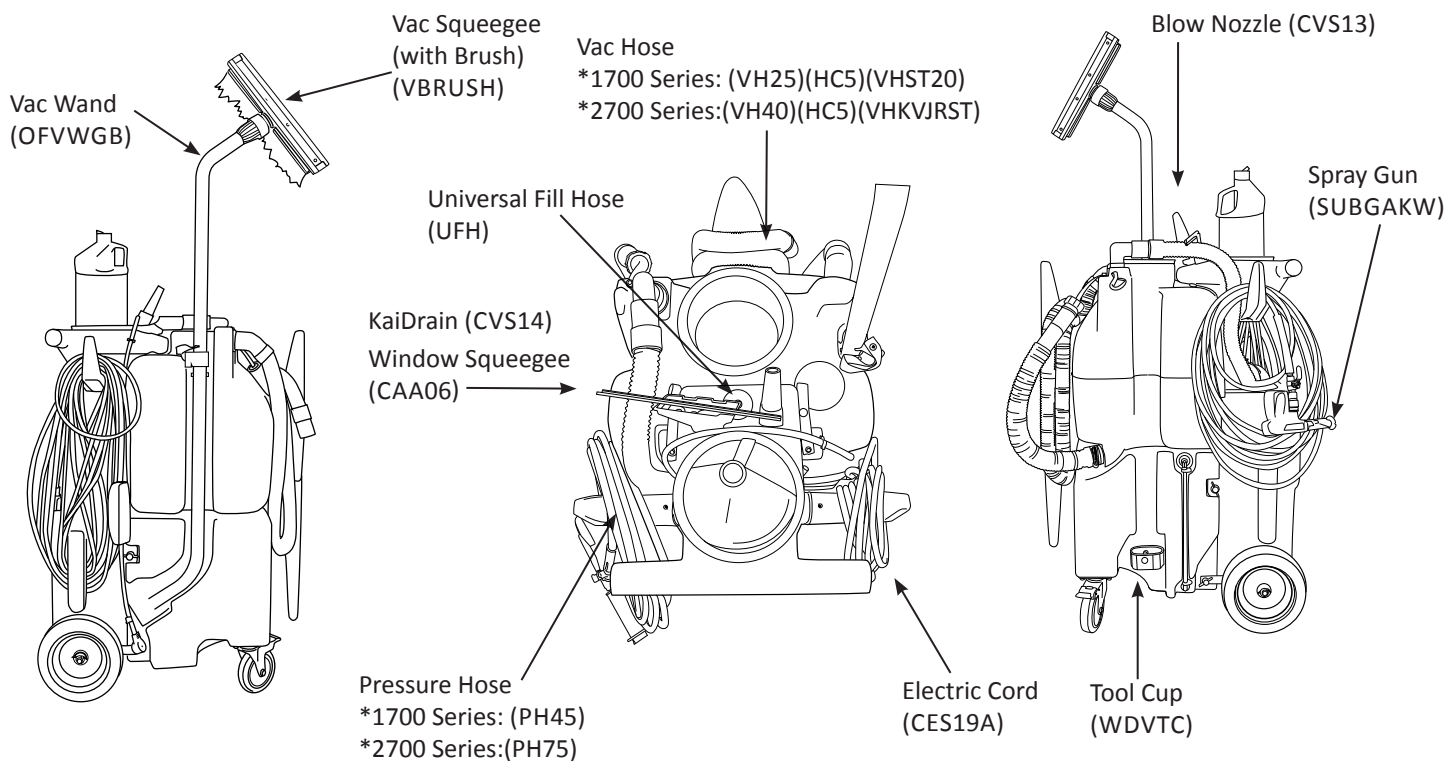

1700 and 2700 Tool Arrangement

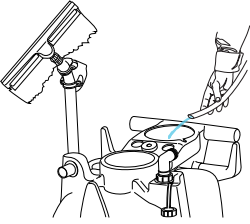
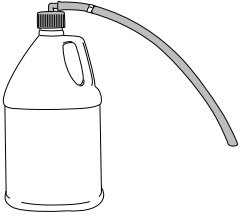
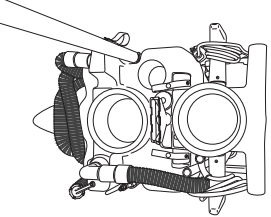

2.3 PREPARATION FOR USE

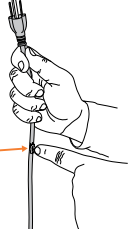
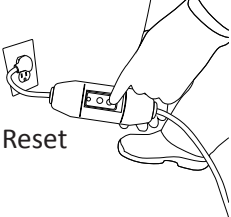
<p>1. Fill machine with clean, cool water.</p>	
<p>2. Prepare the cleaning solution you will be using by attaching the chemical feed line and cap to the top of your chemical bottle. Then select the proper metering tip. (See placard for metering tip information)</p>	
<p>3. Check machine for all tools and supplies needed to complete task. See <i>Tool Arrangement</i> in Section 2.2 of this manual.</p>	
<p>4. If using a cleaning product that foams, use a foam inhibitor to cut excess. Pour 2 capfuls of inhibitor in the Vac Hose with Vac running to coat inside of Hose.</p>	
<p>5. Check all hoses and spray lines for damage prior to use. If damage is found, do not continue until proper repairs are completed.</p>	
<p>6. Plug in machine and test GFCI (Ground Fault Circuit Interrupter) to ensure it is working properly. You are now ready.</p>	

3.1 MACHINE MAINTENANCE

⚠ CAUTION: Always unplug machine before lifting electric cover assembly.

ITEM	PROCEDURE
Floor Squeegee	<ul style="list-style-type: none"> • Check condition of squeegee blades and wheels on the floor tool. • Rough floor surfaces will cause the blades and wheels to wear out more quickly. Replace as necessary.
Spray Gun	<ul style="list-style-type: none"> • Check spray pattern. If spray pattern will not pinpoint, clean orifice by removing it with an Allen wrench and flushing. Replace if needed. • If nozzle becomes difficult to move from high to low pressure, lubricate nozzle with lithium grease.
Pressure Hose	<ul style="list-style-type: none"> • Wipe clean after each use. • Check for cuts or frays in the hose jacket, particularly at the end of the fittings. Replace hose if cuts are found.
Water Tank	<ul style="list-style-type: none"> • Check condition of filter in water tank. Clean as needed. • Empty the water tank to prevent mildew and bacteria growth. Empty tank by dipping the vacuum hose into the water tank and transferring the water to the vacuum tank.
Vacuum Tank	<ul style="list-style-type: none"> • Empty and flush vacuum tank. • Clean and disinfect. • Check the float shutoff screen to be sure it is not blocked or dirty. A plugged filter screen restricts airflow and results in reduced suction.
Leaks	<ul style="list-style-type: none"> • Be alert for leaks around hoses, fittings, spray wand, tanks or elsewhere. • Discontinue use until leaks are repaired.
Electrical System	<ul style="list-style-type: none"> • The ground fault circuit interrupter (GFCI) must be tested before each use. • Electrical cord must be inspected for tears or cuts in the insulation.
Vacuum Wand	<ul style="list-style-type: none"> • Use a wire or coarse brush with acid cleaner to remove residue from threads on the coupling and coupling nut. Apply grease when done.
HEPA Filter	<ul style="list-style-type: none"> • Replace every 3-6 months depending on use.

3.2 VACUUM DIAGRAM

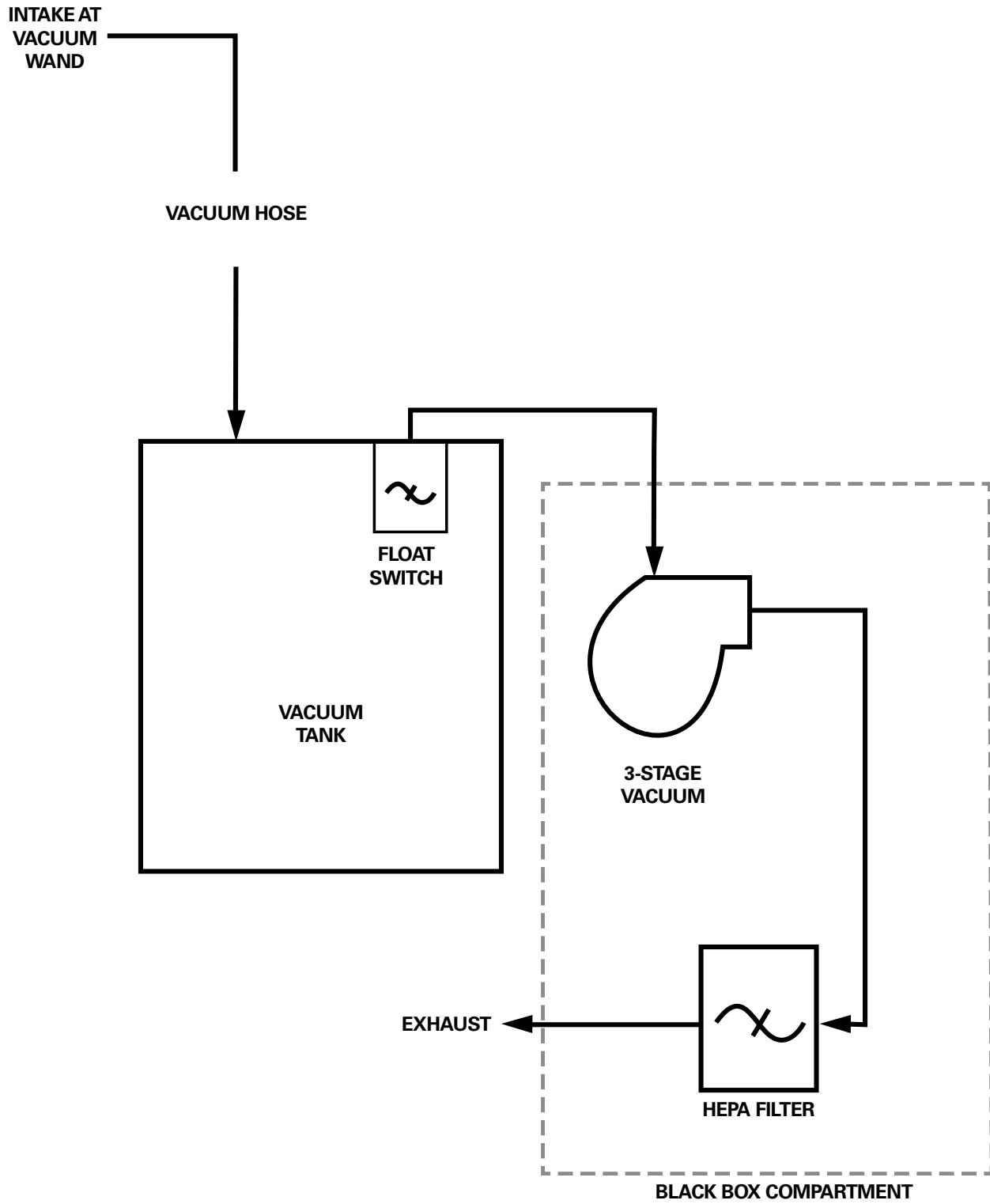

3.3 PUMP DIAGRAM

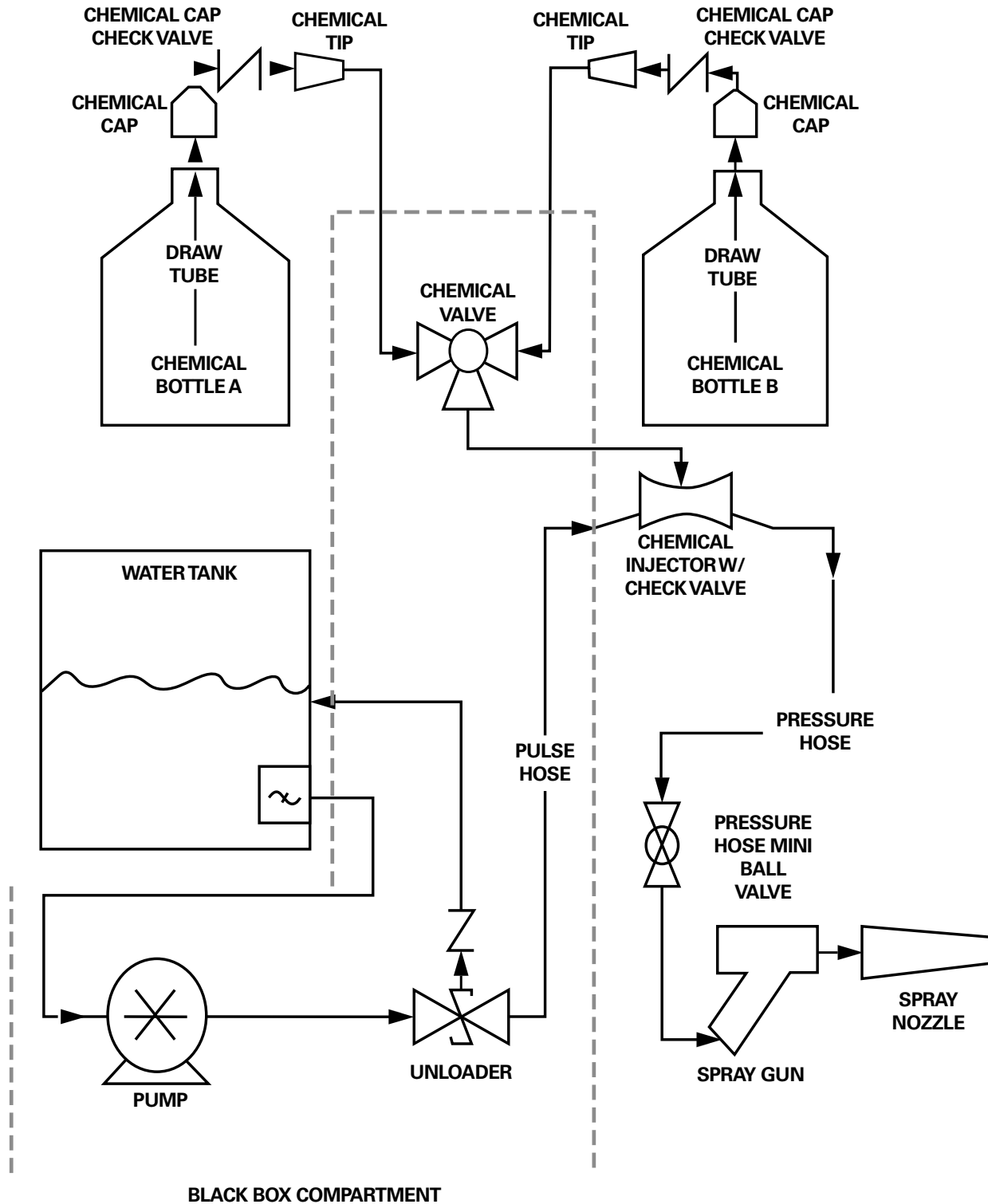

3.4 ELECTRICAL DIAGRAM

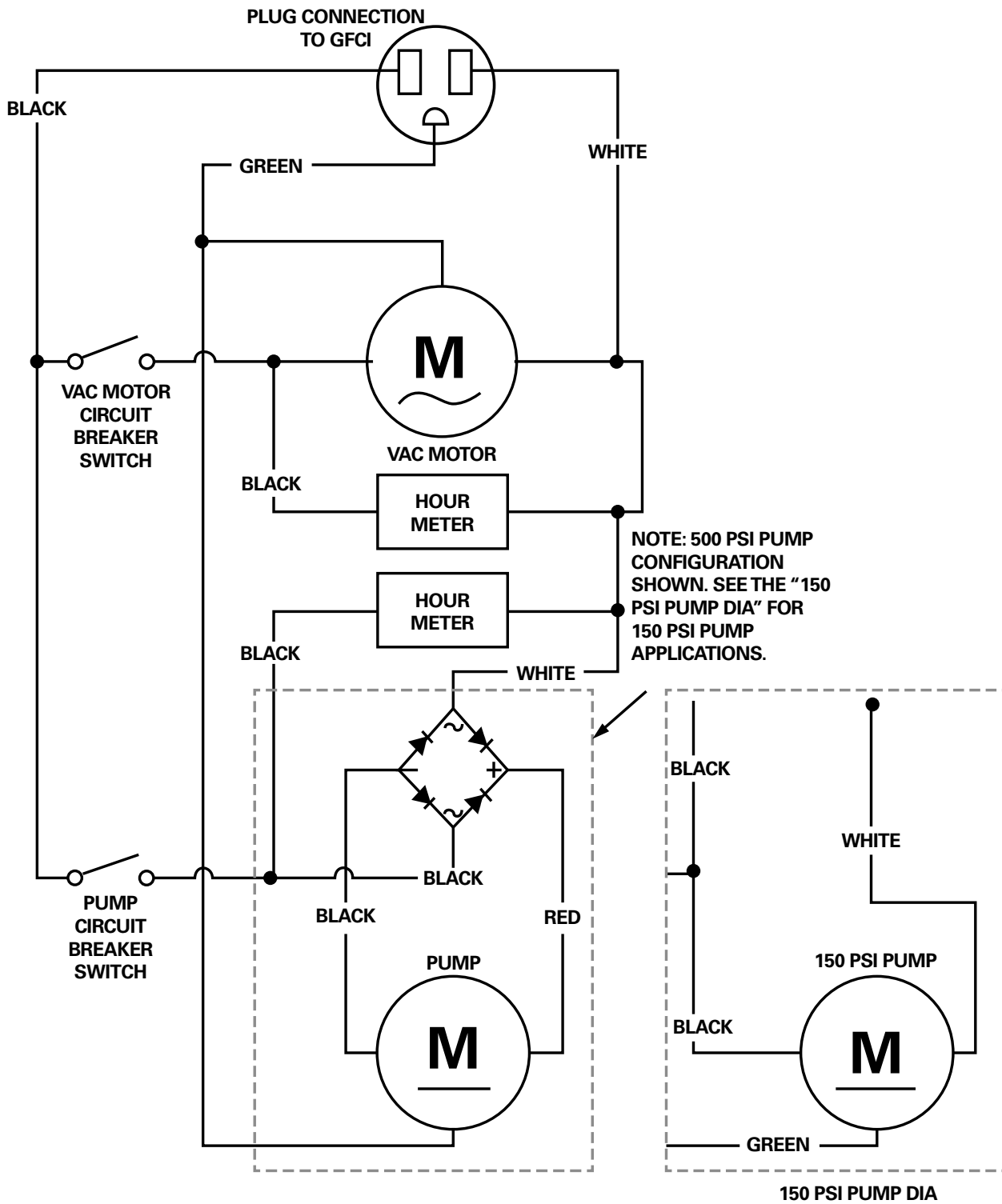

4.1 TROUBLESHOOTING

⚠ CAUTION: Always unplug machine before lifting electric cover assembly.

AREA	PROBLEM	POSSIBLE CAUSE	SOLUTION
Electrical	No Power to pump or vac motor	Machine not plugged in	Plug machine in
		Switch not "on"	Check switches for "on"
		GFCI tripped	Test and reset GFCI
		Building circuit overloaded	Check and reset circuit
		Switch wires loose	Disconnect power and check for loose wire
		Connections loose	Disconnect power and check for loose wire under panel
Electrical	Electrical burning smell	Vac motor brushes worn	Remove vac motor and repair
		Vac motor hung up	Release pressure on hose and jog vac switch, or replace
		Pump motor hung up	Release pressure on hose and jog pump switch, or replace
Vacuum System	No/Weak vacuum	Vac tank full	Empty vac tank
		Squeegee blades or wheels worn	Replace wheels or blades and check periodically
		Float shutoff screen dirty	Spray off float screen to clean
		Float ball stuck	Tap float and release/clean
		Damaged hose	Cut and repair/replace
		Dump hose plug missing	Contact dealer and replace
		Access lid not right	Tighten lid hand tight
		Vacuum hose plugged	Flush hose to remove debris
		Too much liquid in vac hose	Allow air in when vacuuming
		Vac hose still wrapped	Unwrap vac hose fully
		Exhaust plugged	Remove HEPA filter and clean
		Leak in vac tank	If repairable, clean and dry affected area and seal with silicone
	HEPA filter clogged	Remove HEPA filter and clean	
	Moisture from exhaust	Vac tank full	Dump vac tank
		Float shutoff missing	Replace
Excessive foam in vac tank		Use defoamer	
Blow Dry System	No air flow	Hose disconnected	Reconnect hose
	Moisture from exhaust	Water in blow hose	Dry blow line
	Suction, not blow action	Vacuum hose connected to vac tank	Reconnect to vac motor exhaust hose

4.2 TROUBLESHOOTING

⚠ CAUTION: Always unplug machine before lifting electric cover assembly.

AREA	PROBLEM	POSSIBLE CAUSE	SOLUTION
High Pressure System	No water from pump or low pressure	Out of water	Fill water tank
		Gun nozzle plugged	Remove orifice with Allen wrench and clean
		Air in pump (vapor lock)	Use power prime technique
		Gun orifice missing	Replace orifice
		Water tank filter plugged	Clean tank and filter
		In-line bowl filter plugged	Remove filter cover and clean
		Bowl filter lid loose	Gently tighten bowl cover
		Pressure hose damaged	Repair or replace
		Quick disconnect leaking	Tighten or replace
		Injector plugged	Remove safety cap from chemical and blow small amounts of compressed air into line
		Pulse hose damaged	Repair or replace
		Regulator failed	Replace
		Hose kinked	Unkink and check for damage
	Seals in pump need replaced	Remove and replace seals	
	Bad fan pattern or pinpoint pattern on gun	Debris in nozzle	Remove orifice with Allen wrench and clean
Orifice damaged		Remove and replace	
Chemical Injection System	No chemical flow	Out of chemical	Refill chemical
		Safety cap not secure	Check safety cap/tighten
		Chemical valve "off"	Check on/off valve
		Safety cap plugged	Replace cap
		Spray gun in wrong mode	Make sure gun nozzle is pulled out away from gun chemical mode
		Metering tip plugged	Check metering tip for clog
		Injector plugged	Remove safety cap from chemical and blow small amounts of compressed air into line
		Air entering system	Check for air entering system around chemical lines or injector
		Injector installed backwards	If fluttering or pulsing sound can be heard while spraying or when machine is running, it is possible that your injector is in backwards. Remove; reinstall.
		Kink in chemical line	Replace chemical line

4.3 TROUBLESHOOTING

⚠ CAUTION: Always unplug machine before lifting electric cover assembly.

AREA	PROBLEM	POSSIBLE CAUSE	SOLUTION
Chemical Injection System continued	Not enough chemical	Metering tip plugged	Remove and clean
		Wrong metering tip	Check and replace per chart
	Chemical line blows off safety cap	Debris in injector	Remove safety cap from chemical and blow small amounts of compressed air into line
		Water back flows into chemical bottle	Bad seat on injector check valve
Dump System	Dump hose will not empty tank	Dump hose cap not removed	Remove cap
		Clog in bottom of tank	Tip dump contents, remove debris
	Dump hose leaks	Hose cut	If leak is less than 4" from tank side, cut and reattach, or replace
		Clamp loose	Tighten hose clamp
		Dump cap missing	Replace cap
Wheels and Casters	Wheels will not roll; rubbing	Flat tires	Inflate tires to 30 p.s.i.
		Debris wrapped around axle	Check for debris on axle
		Bearings tight	Grease bearings
		Wheels too loose on axle	Remove wheel, add washers to take up slack
		Bearings falling out	Replace bearing assembly
Squeegee Head	Floor streaks	Worn blades or wheels	Replace wheels and/or blades
	Squeegee head does not easily rotate when installed on wand	Brass ring on wand not in groove	Loosen coupling nut and re-position head on groove
		Coupling nut too tight	Loosen 1/2 turn
	Head will not stay on wand	Coupling nut cracked	Replace
		Brass ring worn	Replace
	Premature blade wear	Squeegee wheels worn	Check wheels for wear/replace
Sucks to the floor too tightly	Squeegee wheels worn	Check wheels for wear/replace	

4.4 TROUBLESHOOTING TIPS

• POOR VACUUM PICKUP

1. Check Squeegee Blades. If blades are worn or damaged, replace Squeegee Head.
2. Clean float cage.
3. Check for leaks in the Vacuum Hose or Gasket.
4. Check for clogged Vacuum Hose.
5. Check to see if float ball was tripped.

• VACUUM SHUTS OFF PREMATURELY

1. Check Float Cage; clean if dirty.
2. Cleaning Chemicals may be producing too much foam. Use correct Chemicals.

• OTHER ISSUES? CONTACT TECHNICAL SUPPORT

PHONE:

United States and Canada: 1-800-287-1136

International: 1-513-887-4600

EMAIL:

info@kaivac.com

For Technical Support Contact Form go to: <https://www.kaivac.com/contactus.php> and choose Technical Support tab.

4.5 REPLACEMENT (MONTHLY)

The following tasks should be performed monthly to keep your system operating at peak performance.

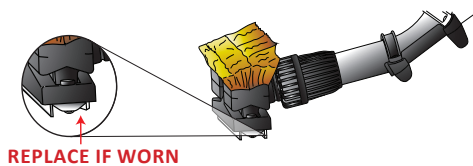

Check for worn squeegee blades. Worn blades cause streaking and loss of vacuum suction.

Unscrew cuff at end of Vac Wand, remove old head and replace with new every 6-8 weeks for optimal performance.

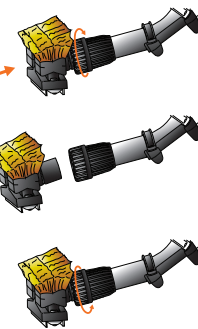

5.1 1200 VAC TANK ASSEMBLY

[P/N: VTA1200]

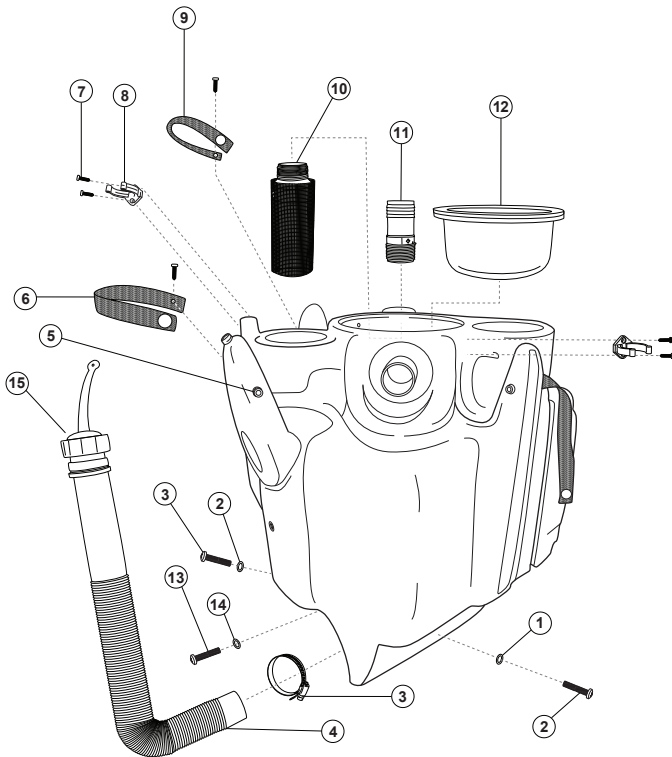

#	PART NO.	PART DESCRIPTION
1	KMB16	3/8 SST FLAT WASHER
2	CSS91	3/8 X 2 1/4 BOLT
3	CSS03	1 9/16 - 2 1/2 HOSE CLAMP
4	DH25	26" X 1.5" DUMP HOSE 2" CUFF
5	CSS20	SNAP STUD
6	SUBSS7	7 IN. SNAP AND STRAP
7	CSS17	#8 FLAT HEAD SQUARE SCREW
8	CSS14	13 CLAMP, FOR TOOLS
9	SUBSS9	9 IN. SNAP AND STRAP
10	KZFLOAT	FLOAT SHUT OFF
11	CSS173	1 1/4 NPT X 1 1/2 HOSE ADAPTER
12	VLJHA	VAC LID, JUG HOLDER ASSEMBLY
13	CSS58	3/8 X 16 X 1 SST SCREW
14	CSS48	3/8 SST LARGE OD WASHER
15	SCCAP	DUMP HOSE CAP

5.2 1200 WATER TANK ASSEMBLY

[P/N: WTA1200]

#	PART NO.	PART DESCRIPTION
1	CSS14	13 CLAMP, FOR TOOLS
2	CSS17	#8 FLAT HEAD SQUARE SCREW
3	LID4	LID WITH TETHER 4 1/4 IN
4	MFILT	MUSHROOM FILTER
5	CSS142	3/8 IN BRASS HOSE BARB
6	CPS20	3/8 NPT X 1/2 BRASS HOSE BARB
7	LCST4	4 TOTAL LOCK CASTER
8	CSS133	5/16 SPLIT LOCK WASHER 300 SS
9	CSS132	5/16-18X1 BUTTON HEAD

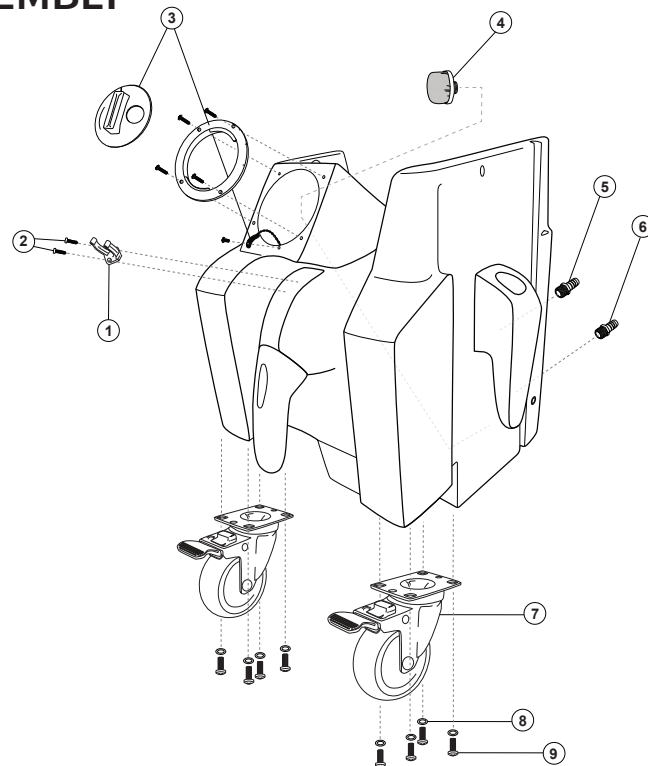

5.3 1250 BLACK BOX ASSEMBLY

[P/N: BBA1250R, BBA1250240V (AUS, EU, UK)]

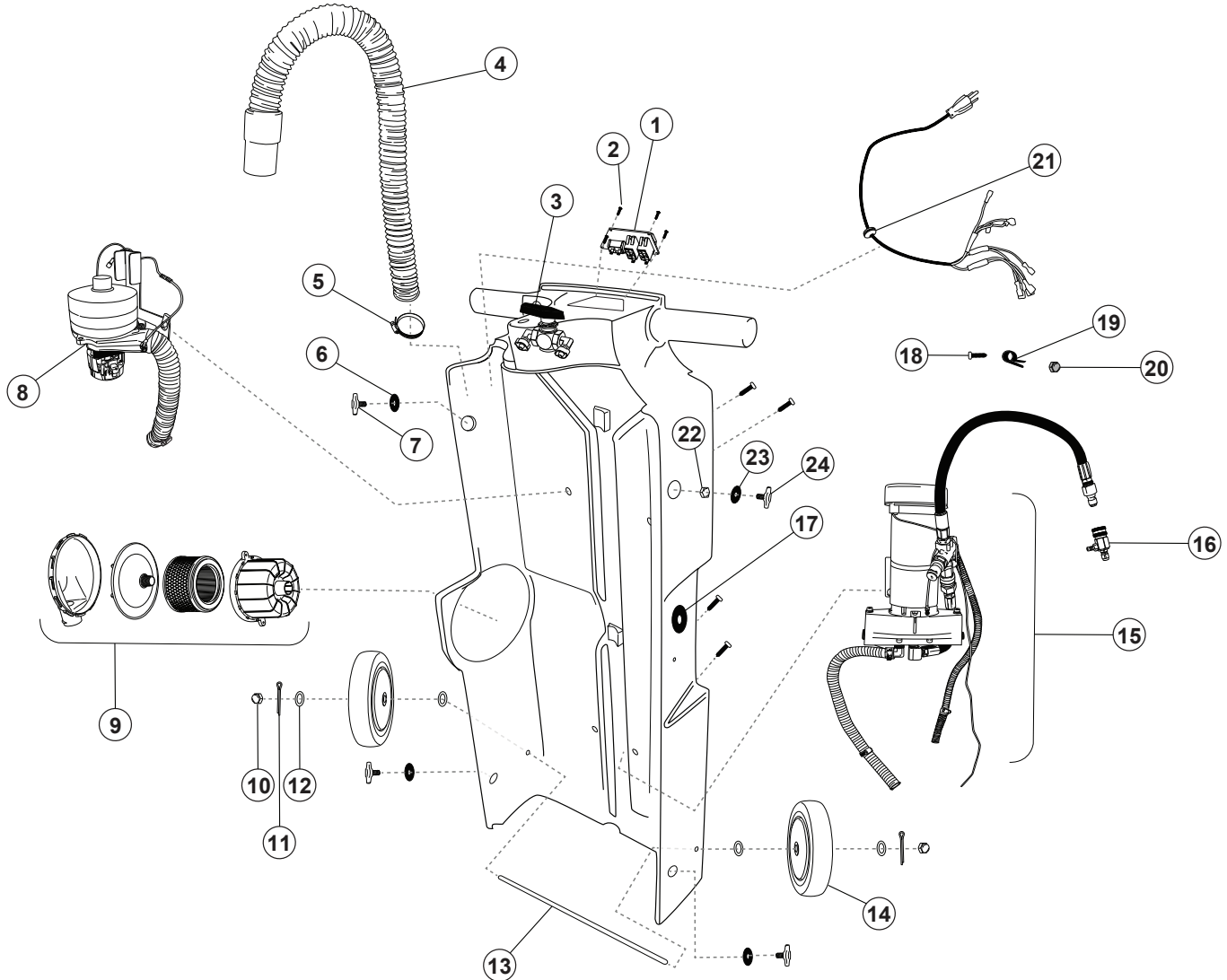

#	PART NO.	PART DESCRIPTION
1	SPA1250	SWITCH PANEL ASSEMBLY FOR KV1250
2	CSS17A	8 SST SCREW 3/4
3	VA2W	VALVE ASSEMBLY 2 WAY FOR KV1250
4	VMH27	VAC MOTOR HOSE NEW
5	CSS03	1 9/16 - 2 1/2 HOSE CLAMP
6*	CSS48	3/8 SST LARGE OD WASHER
7*	CSS156	3/8 X 3/4 T THUMB SCREW YELLOW
8A	VMA1200	VAC MOTOR ASY KV1200
8B	VMA1250240V	VAC MOTOR ASY KV1250
9	HEPAHA2	HEPA HOUSING ASSEMBLY
10	CSS01	1/2 IN PUSH CAP NUT
11	CSS72	COTTER PIN 1/8 DIA X 11/4 LG
12	CSS40	1/2 DIA WASHERS

13	AX195	AXLE 19.75 X 1/2 CR STEEL
14	WHL5	5 X 1 1/2 TPU WHEEL W-1/2 BB
15A	PA1250	PUMP ASSEMBLY FOR KV1200
15B	PA1250240V-2	PUMP ASSEMBLY FOR KV1250
16	CPS12JQC	QUICK CONNECT INJECTOR
17	CSS175	3/4 ID X 1 3/8 OD GROMMET
18	CSS174	1/4-20 X 5/8 MACHINE SCREW SS
19	CSS130	RUBBER CUSHIONED STEEL LOOP
20	CSS101	ACORN NUT 1/4 20
21A	PCKV1A	POWER CORD MOLDED WITH GROMMET
21B	CES20 (AUS, EU, UK)	POWER CORD MOLDED WITH GROMMET
22	CSS54	3/8 HEX NUT
23	CSS48	3/8 SST LARGE OD WASHER
24	CSS308	1200 BLACK BOX HOSE HOOK

* Shown but not part of assembly

5.4 1200 SWITCH PANEL ASSEMBLY

[P/N: SPA1250]

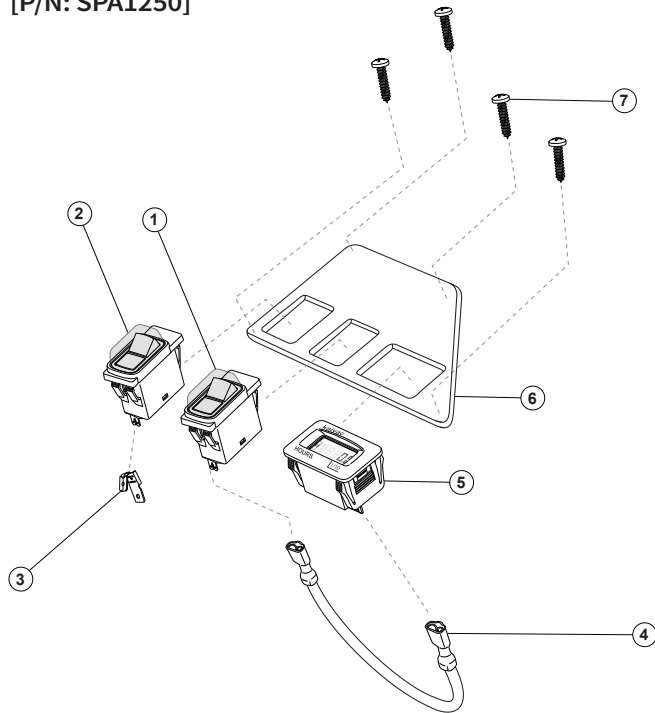

#	PART NO.	PART DESCRIPTION
1	5ACBS (PUMP)	5 AMP CIRCUIT BREAKER SWITCH BLACK
2	15ACBS (VAC)	15 AMP CIRCUIT BREAKER SWITCH WHITE
3	CSS123	QUICK CONNECT PIGGY BACK TERM
4	JWB5	JUMPER WIRE BLACK 5 IN
5	HMETER	SNAP IN DIGITAL METER
6	SPLSSB1200	SWITCH PLATE SS W/ BREAKER
7*	CSS17A	8 SST SCREW 3/4

* Shown but not part of assembly

5.5 1200 VALVE ASSEMBLY

[P/N: VA2W]

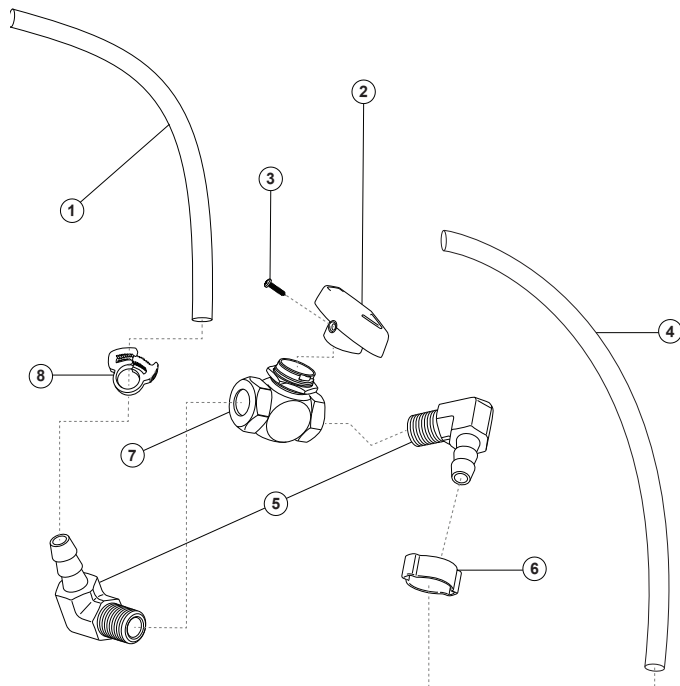

#	PART NO.	PART DESCRIPTION
1	SPH18	2 WAY VALVE HOSE FOR KV1250
2	CPS50B	BLACK KNOB FOR 3 WAY VALVE
3	CPS50C	SET SCREW FOR 3 WAY VALVE
4	SPH24	ELECT BOX CHEMICAL HOSE 24 IN
5	CPS68	90 DEG 1/8 NPT MALE X
6	CPS65	1/2 IN CLAMP
7	CPS43A	2 WAY BRASS VALVE VITON SEALS (INCLUDES KNOB)
8	CSS21F	SNAP GRID HOSE CLAMP SIZE C

5.6 1250 PUMP ASSEMBLY

[P/N: PA1250, PA1250240V-2]

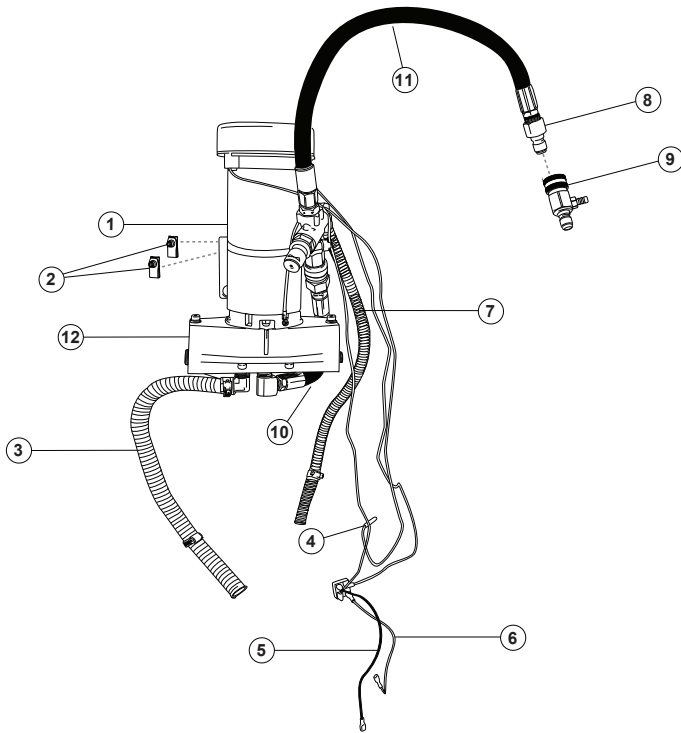

#	PART NO.	PART DESCRIPTION
1	PMA217	MOTOR ONLY
2	CSS08	5/16-18 U-NUT
3	WL1750	WATER LINE FOR 1750
4	CSS127	QUICK DISCONNECT TERMINAL
5	JWB	JUMPER WIRE BLACK 12 IN
6	JWW	JUMPER WIRE WHITE 12 IN
7	RL1750	RETURN LINE FOR 1750
8	CPS38	3/8 QD PLUG
9*	CPS12JQC	QUICK CONNECT INJECTOR
10	CPS14B	PULSE HOSE SHORT
11	CPS14	PULSE HOSE LONG
12	PUMPSPARE217	PUMP ONLY

* Shown but not part of assembly

5.7 1200 VAC MOTOR ASSEMBLY

[P/N: VMA1200, VMA1250240V]

#	PART NO.	PART DESCRIPTION
1	CSS203	HEX BOLT 1/4 20 X 1 1/4
2	CSS44	1/4 FLAT WASHER
3A	CVM1R	MOTOR FOR BUILDS
3B	CVM240V	3 STAGE VAC MOTOR 240V
4	HFH16	HEPA FILTER HOSE 16 IN
5	CSS39	1 1/16-2 HOSE CLAMP
6	CSS11	NO 10 3/4 SELF DRILLING
7	CSS27	1/4 NYLOC NUT
8	VBRAK	VAC MOTOR BRACKET KV1200
9	CSS08	5/16-18 U NUT
10	VMH27	VAC MOTOR HOSE

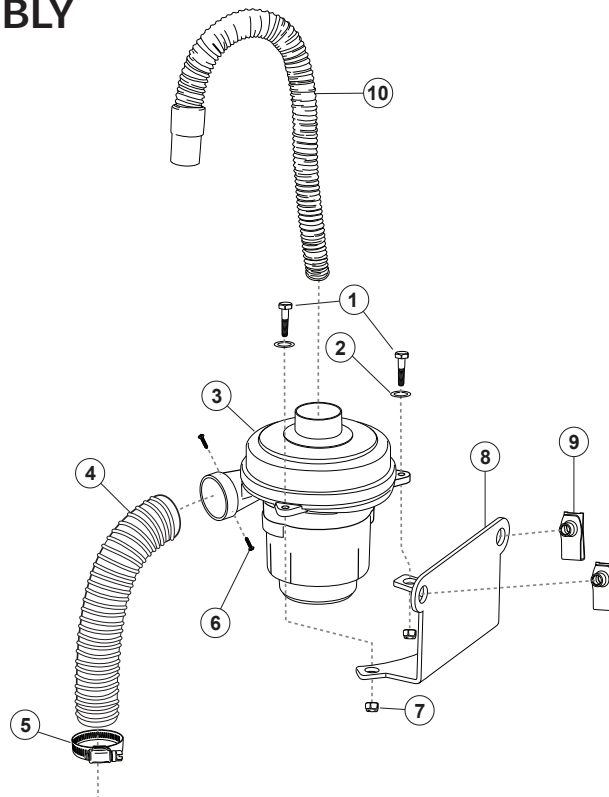

5.8 1700/17001 VAC TANK ASSEMBLY

[P/N: VTA18, VTA17]

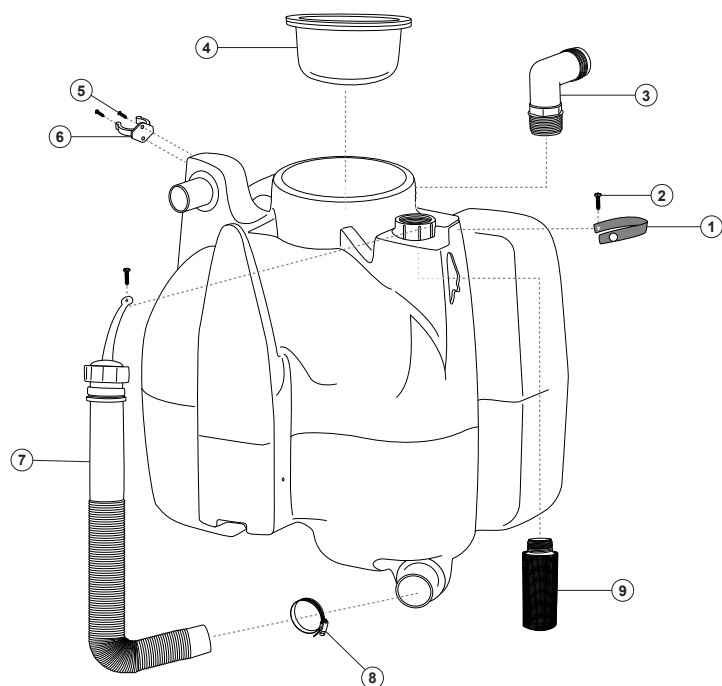

#	PART NO.	PART DESCRIPTION
1	SUBSS11	11 IN SNAP AND STRAP
2	CSS20	SNAP STUD
3	CSS144	1 1/4 NPT X 1 1/2 HOSE BARB
4	VLJHA	VAC LID, JUG HOLDER ASSEMBLY
5	CSS17	#8 FLAT HEAD SQUARE SCREW
6	CSS14	13 CLAMP, FOR TOOLS
7	DH25	26" X 1.5" DUMP HOSE 2" CUFF
8	CSS03	1 9/16 - 2 1/2 HOSE CLAMP
9	KZFLOAT	FLOAT SHUT OFF

5.9 1700/17001 WATER TANK ASSEMBLY

[P/N: WTA20, WTA17]

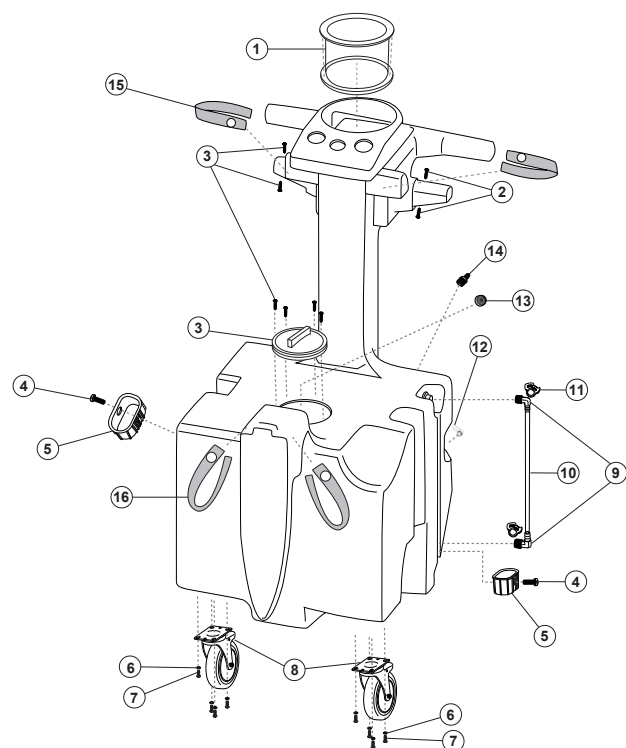

#	PART NO.	PART DESCRIPTION
1	VLJHA	VAC LID, JUG HOLDER ASSEMBLY
2	CSS17A	8 SST SCREW 3/4
3	LID4	LID WITH TETHER 4 1/2 IN
4	CSS88	1/4 20 X 3/4 SST SCREW
5	WDVTC	TOOL CUP
6	CSS133	5/16 SPLIT LOCK WASHER 300 SS
7	CSS132	5/16-18X1 BUTTON HEAD
8	CFS03	5 IN CASTER, MOUNTING PLATE
9A	CSS158	90 DEG BRASS 3/8 NPT X 1/2 HOSE
9B	CSS143	3/8 IN 90 DEG BRASS BARB
10A	ST16	SIGHT TUBE 16 IN 1/2 ID
10B	ST14	SIGHT TUBE 13 1/2 IN ID
11A	CSS114	NYLON SNAP GRIP CLAMP SIZE F
11B	CSS21	SNAP GRIP HOSE CLAMP SIZE D
12	CSS158	90 DEG BRASS 3/8 NPT X 1/2 HOSE
13	MFLT	MUSHROOM FILTER
14	CSS142	3/8 IN BRASS HOSE BARB
15	SUBSS4	4 IN SNAP AND STRAP
16	SUBSS6	6 IN SNAP AND STRAP

5.10 1750/17501 BLACK BOX ASSEMBLY

[P/N: BBA1750R, BBA217E, BBA1750240V (AUS, EU, UK), BBA17501R, BBA17501E, BBA17501240V (AUS, EU, UK)]

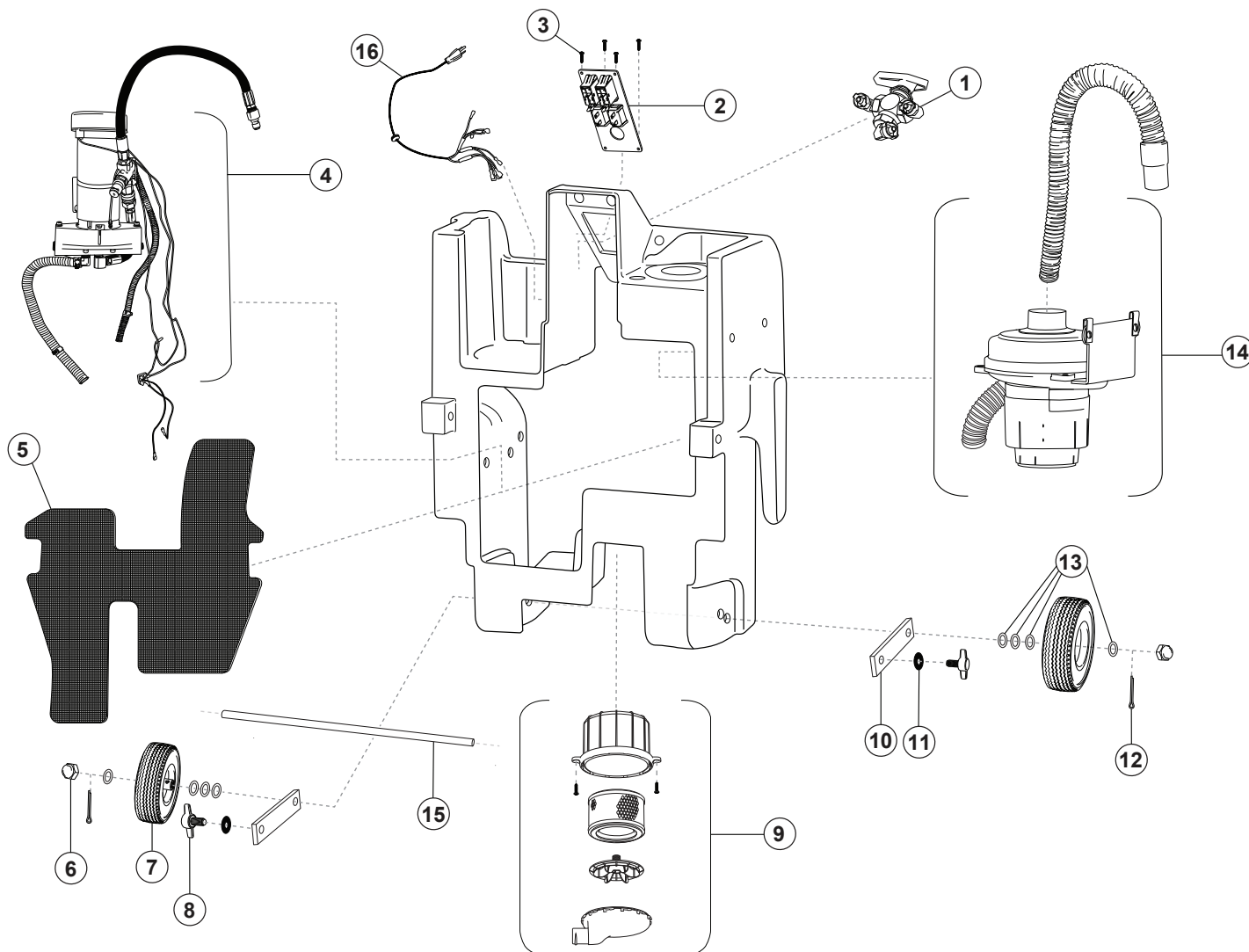

#	PART NO.	PART DESCRIPTION
1	VA3W	VALVE ASSEMBLY 3 WAY
2A	SPADC	SWITCH PANEL ASSEMBLY
2B	SPADCE	SWITCH PANEL ASSEMBLY FOR ETL
3	CSS17A	#8 SST SCREW 3/4
4A	PA217	PUMP ASSEMBLY COMPLETE KV1750
4B	PA217E	PUMP ASSEMBLY COMPLETE FOR KV1750 ETL
4C	PA1750240V-2	PUMP ASSEMBLY COMPLETE KV1750
5A	SPLATE17	SPLASH PLATE FOR 1700
5B	SPLATE17B	SPLASH PLATE 17001 - 27501
6	CSS01	1/2 IN PUSH CAP NUT
7	WHEEL8B	FLAT FREE TIRE 8 IN 1/2 HUB
8*	CSS156	3/8 X 3/4 T THUMB SCREW YELLOW

9	HEPAHA2	HEPA HOUSING ASSEMBLY
10	AXSTRAP	AXLE STRAP
11*	KMB16	3/8 SST FLAT WASHER
12	CSS72	COTTER PIN 1/8 DIA X 11/4 LG
13	CSS40	1/2 DIA WASHERS
14A	VMA1700R	HE 120V VMA 1700
14B	VMA1700E	HE 120V VMA 1700 ETL
14C	VMA240V	1750 VAC MOTOR ASSEMBLY 240V
15	AX205	AXLE 20.5 IN X 1/2 DIA 303 SST
16A	PCKV1A	POWER CORD MOLDED W/ GROMMET
16B	PCKV1TA	POWER CORD MOLDED W/ GROMMET & TWIST LOCK
16C	CES20 (AUS, EU, UK)	50' PRONG CORD WITH RCD

* Shown but not part of assembly

5.11 1700/17001 SWITCH PLATE ASSEMBLY

[P/N: SPADC, SPADCE]

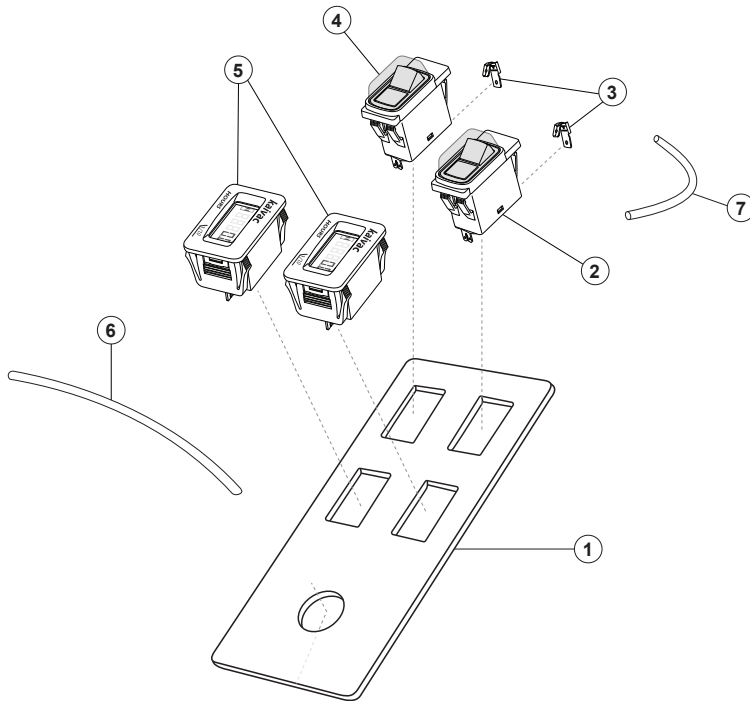

#	PART NO.	PART DESCRIPTION
1	SPDCSSB	SWITCH PNL DUALCHEM FOR BREAKER SWITCH
2	5ACBS	5 AMP PUMP CIRCUIT BREAKER SWITCH
3	CSS123	QUICK CONNECT PIGGY BACK TERM
4	15ACBS	15 AMP VAC CIRCUIT BREAKER SWITCH WHT
5	HMETER	SNAP IN DIGITAL HOUR METER
6	JWW	JUMPER WIRE WHITE 12 IN
7	JWB5	JUMPER WIRE BLACK 5 IN

5.12 1700/17001 VALVE ASSEMBLY

[P/N: VA3W]

#	PART NO.	PART DESCRIPTION
1	CPS50A	3 WAY BRASS VALVE WITH VITON SEAL (INCLUDES KNOB)
2	CPS50B	BLACK KNOB 3 WAY VALVE
3	CPS68	90 DEG 1/8 NPT M X 1/4 BARB
4	CPS65	1/2 IN CLAMP
5	SPH34	SWITCH PANEL HOSE 34 IN
6	SPH18	SWITCH PANEL HOSE 18 IN
7	SPH9	SWITCH PANEL HOSE 9 IN

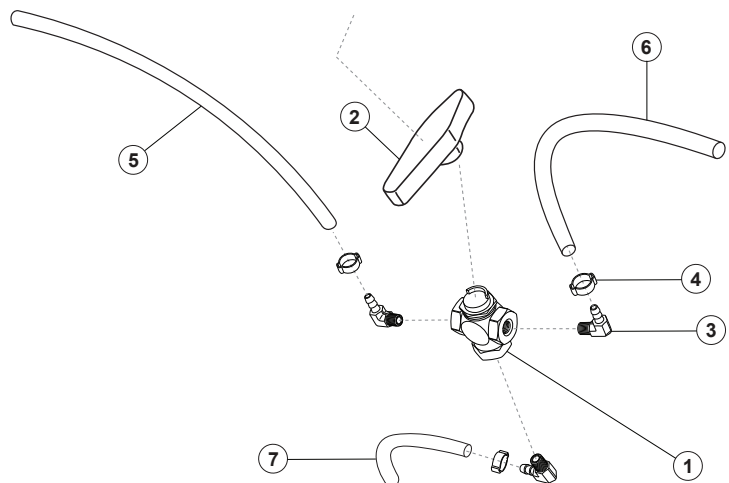

5.15 27001 VAC TANK ASSEMBLY

[P/N: VTA27]

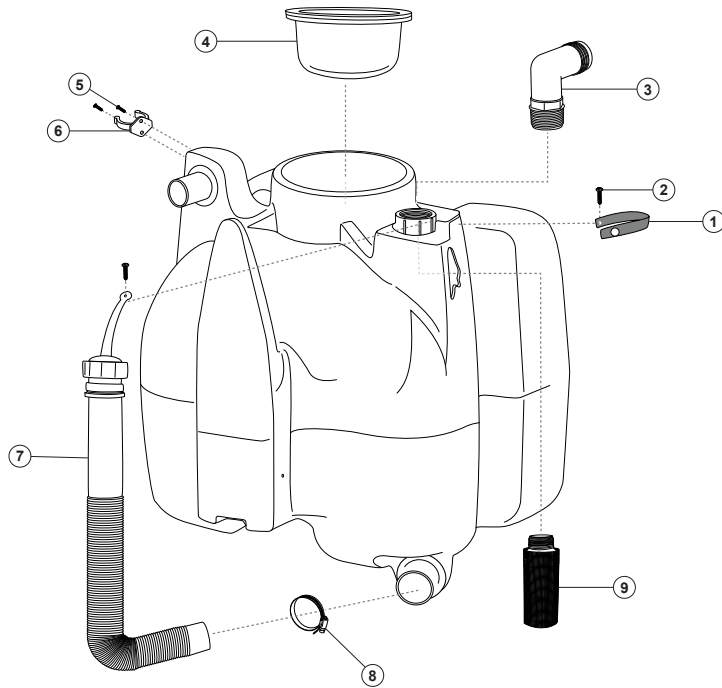

#	PART NO.	PART DESCRIPTION
1	SUBSS11	11 IN SNAP AND STRAP
2	CSS20	SNAP STUD
3	CSS144	1 1/4 NPT X 1 1/2 HOSE BARB
4	VLJHA	VAC LID, JUG HOLDER ASSEMBLY
5	CSS14	13 CLAMP, FOR TOOLS
6	CSS17	#8 FLAT HEAD SQUARE SCREW
7	DH25	26" X 1.5" DUMP HOSE 2" CUFF
8	CSS03	1 9/16 - 2 1/2 HOSE CLAMP
9	KZFLOAT	FLOAT SHUT OFF

5.16 27001 WATER TANK ASSEMBLY

[P/N: WTA27]

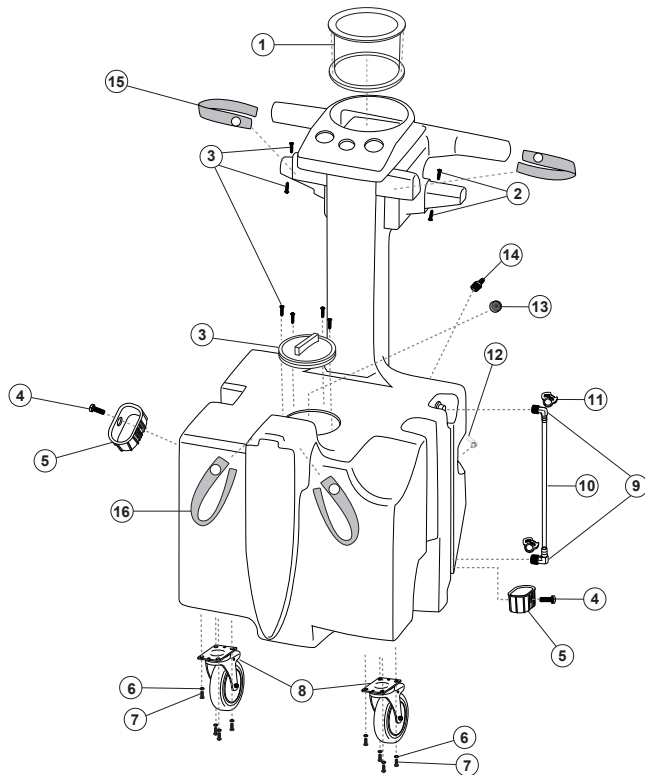

#	PART NO.	PART DESCRIPTION
1	VLJHA	VAC LID, JUG HOLDER ASSEMBLY
2	CSS17A	8 SST SCREW 3/4
3	LID4	LID WITH TETHER 4 1/2 IN
4	CSS88	1/4 20 X 3/4 SST SCREW
5	WDVTC	TOOL CUP
6	CSS133	5/16 SPLIT LOCK WASHER 300 SS
7	CSS132	5/16-18X1 BUTTON HEAD
8	CFS04	6 IN CASTER, MOUNTING PLATE
9	CSS143	3/8 IN 90 DEG BRASS HOSE BARB
10	ST16B	SIGHT TUBE 16.25 IN 3/8 ID
11	CSS21	SNAP GRIP HOSE CLAMP SIZE D
12	CSS158	90 DEG BRASS 3/8 NPT X 1/2 HOSE
13	MFILT	MUSHROOM FILTER
14	CSS142	3/8 IN BRASS HOSE BARB
15	SUBSS4	4 IN SNAP AND STRAP
16	SUBSS7	7 IN SNAP AND STRAP

5.17 27501 BLACK BOX ASSEMBLY

[P/N: BBA27501R, BBA27501240V (AUS, EU, UK)]

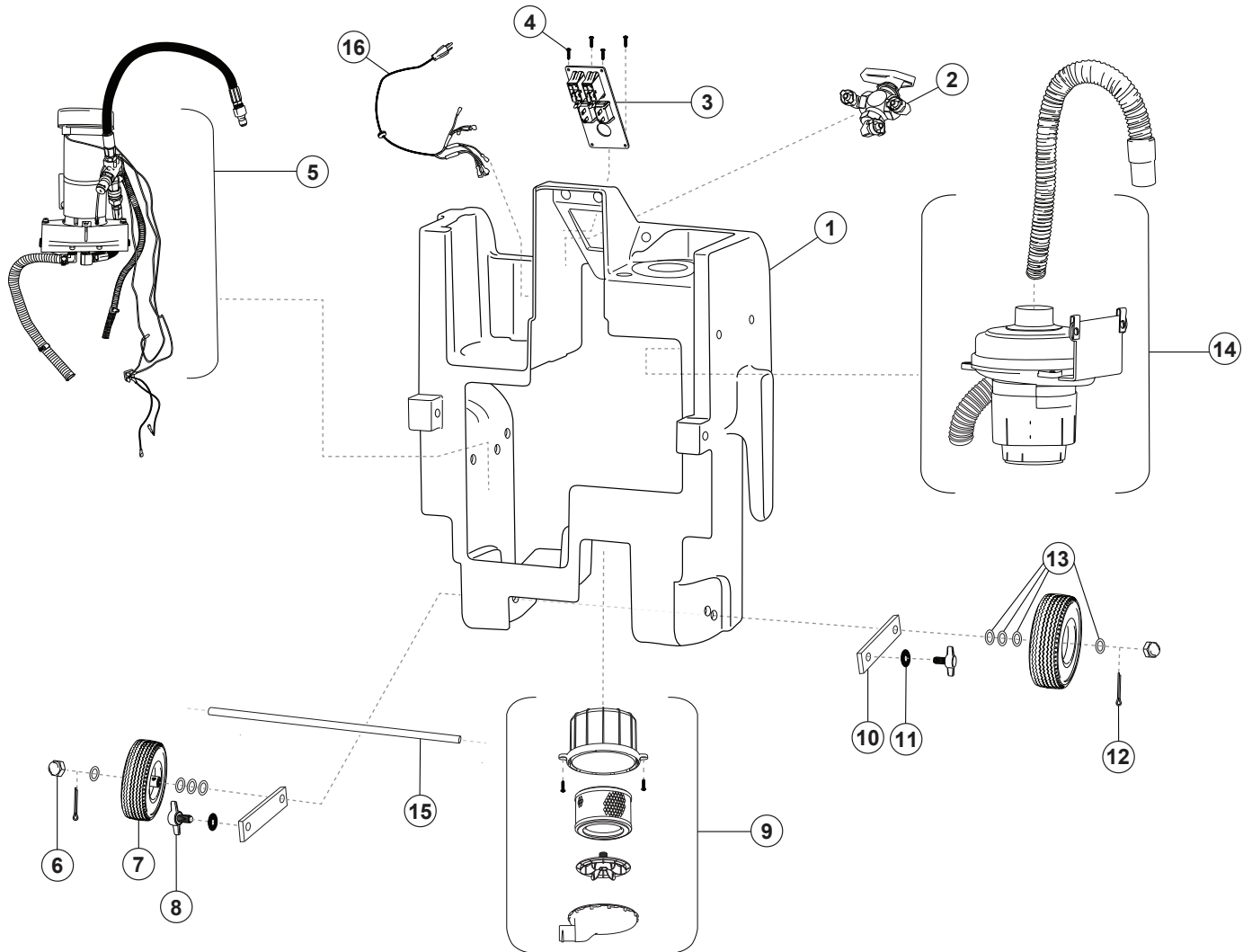

#	PART NO.	PART DESCRIPTION
1	BBNTC	BLACK BOX NTC
2	VA3W27	VALVE ASSEMBLY 3 WAY
3	SPADC	SWITCH PANEL ASSEMBLY
4	CSS17A	#8 SST SCREW 3/4
5A	PA217	PUMP ASSEMBLY COMPLETE KV1750
5B	PA1750240V-2	PUMP ASSEMBLY COMPLETE KV1750
6	CSS43	5/8 PUSH CAP NUT
7	WHEEL10	FLAT FREE TIRE 10 IN 5/8 HUB
8	CSS156	3/8 X 3/4 T THUMB SCREW YELLOW

9	HEPAHA2	HEPA HOUSING ASSEMBLY
10	AXSTRAP	AXLE STRAP
11	KMB16	3/8 SST FLAT WASHER
12	CSS72	COTTER PIN 1/8 DIA X 11/4 LG
13	CSS46	5/8 STEEL WASHER
14A	VMA27001	HE 120V VMA 27001
14B	VMA27001240V	HE 240V VMA 27001
15	AX21	AXLE 21 IN X 5/8 DIA
16A	PCKV1A	POWER CORD MOLDED W/ GROMMET
16B	CES20 (AUS, EU, UK)	50' CORD WITH RCD

5.18 27001 SWITCH PLATE ASSEMBLY

[P/N: SPADC]

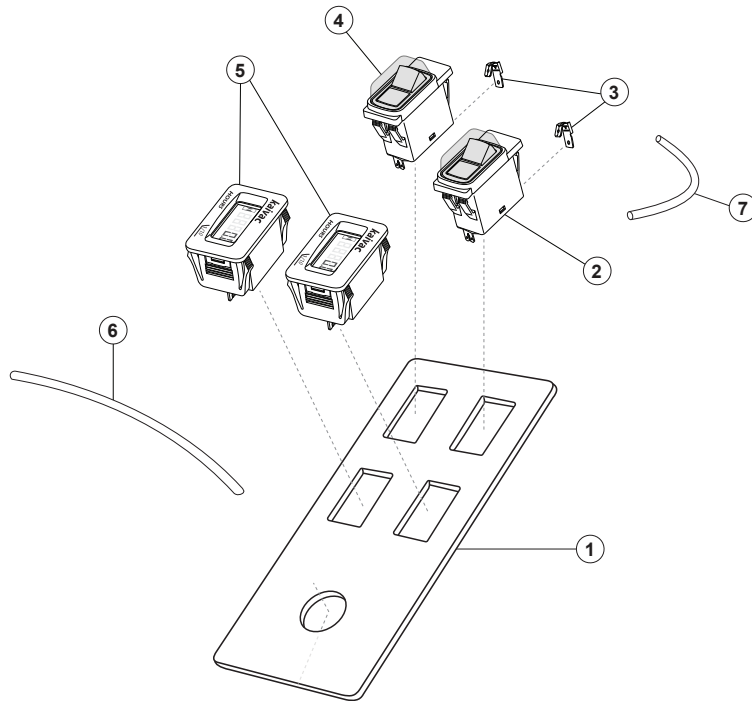

#	PART NO.	PART DESCRIPTION
1	SPDCSSB	SWITCH PNL DUALCHEM FOR BREAKER SWITCH
2	5ACBS	5 AMP PUMP CIRCUIT BREAKER SWITCH
3	CSS123	QUICK CONNECT PIGGY BACK TERM
4	15ACBS	15 AMP VAC CIRCUIT BREAKER SWITCH WHT
5	HMETER	SNAP IN DIGITAL HOUR METER
6	JWW	JUMPER WIRE WHITE 12 IN
7	JWB5	JUMPER WIRE BLACK 5 IN

5.19 27001 VALVE ASSEMBLY

[P/N: VA3W25]

#	PART NO.	PART DESCRIPTION
1	CPS50A	3 WAY BRASS VALVE WITH VITON SEAL (INCLUDES KNOB)
2	CPS50B	BLACK KNOB 3 WAY VALVE
3	CPS68	90 DEG 1/8 NPT M X 1/4 BARB
4	CPS65	1/2 IN CLAMP
5	SPH43	SWITCH PANEL HOSE 43 IN
6	SPH18	SWITCH PANEL HOSE 18 IN
7	SPH9	SWITCH PANEL HOSE 9 IN

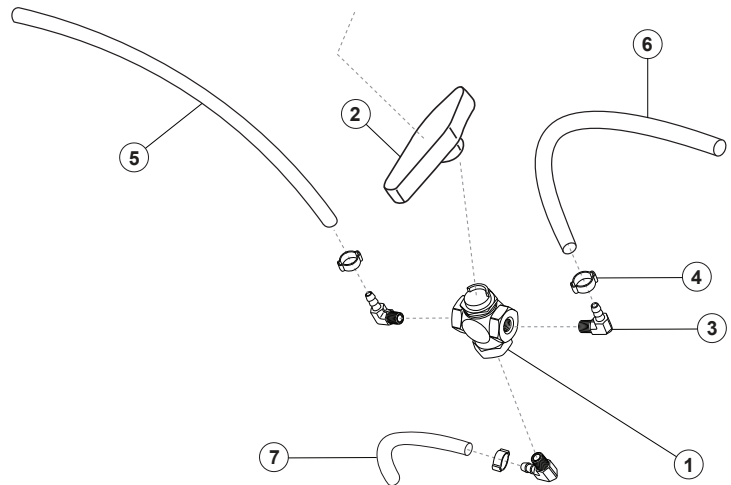

5.20 27501 PUMP ASSEMBLY

[P/N: PA217, PA1750240V-2]

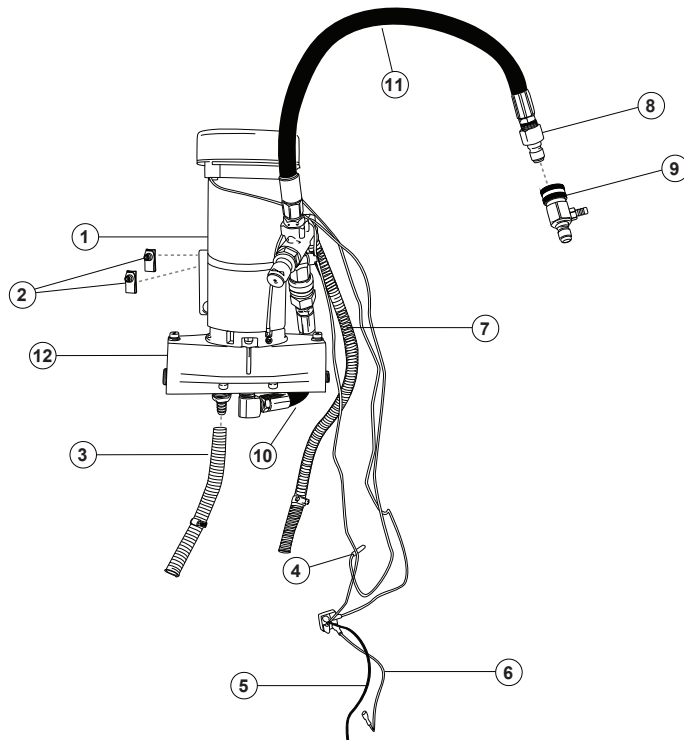

#	PART NO.	PART DESCRIPTION
1A	PA217	PUMP ASSEMBLY
1B	PUMP217240VDC	PUMP SERIES 217240VDC
1C	PMA217	MOTOR ONLY
2	CSS08	5/16-18 U-NUT
3	WL1750	WATER LINE FOR 1750
4	CSS127	QUICK DISCONNECT TERMINAL
5	JWB	JUMPER WIRE BLACK 12 IN
6	JWW	JUMPER WIRE WHITE 12 IN
7	RL1750	RETURN LINE FOR 1750
8	CPS38	3/8 QD PLUG
9*	CPS12JQC	QUICK CONNECT INJECTOR
10	CPS14B	PULSE HOSE SHORT
11	CPS14	PULSE HOSE LONG
12	PUMPSPARE217	PUMP ONLY

* Shown but not part of assembly

5.21 27001 VAC MOTOR ASSEMBLY

[P/N: VMA27001, VMA27001240V]

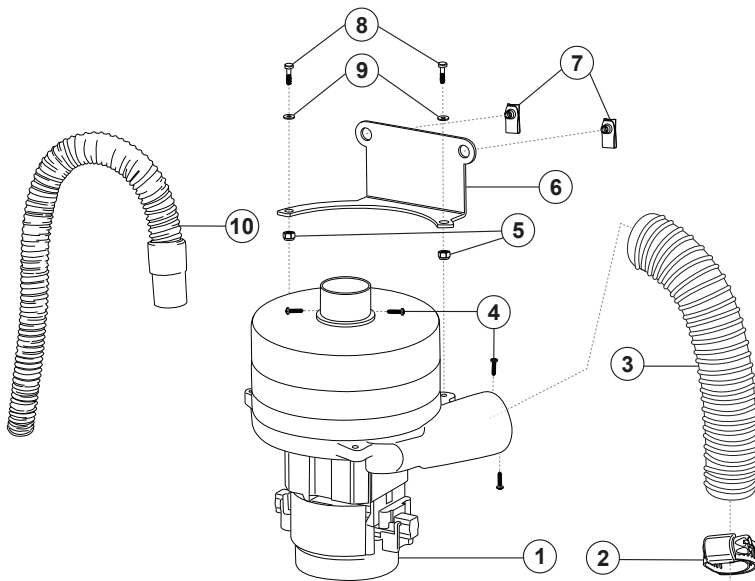

#	PART NO.	PART DESCRIPTION
1A	HEVM1	HIGH EFFICIENCY 120V VAC MOTOR
1B	HEVM1240V	HIGH EFFICIENCY VAC MOTOR 240V
2	CSS39	1 1/16 - 2 HOSE CLAMP
3	VEH19	VAC MOTOR EXHAUST HOSE 19 IN
4	CSS11	NO 10 X 3/4 SELF DRILLING
5	CSS27	1/4 NYLOC NUT
6	VBRAK4	VAC MOTOR BRKT KV1700
7	CSS08	5/16-18 U-NUT
8	CSS203	HEX HEAD BOLT 1/4 20 X 1 1/4
9	CSS44	1/4 FLAT WASHER
10	VMH34A	VAC MOTOR HOSE SHORT CUFF 34 IN

5.22 HEPA ASSEMBLY

[P/N: HEPAHA2]

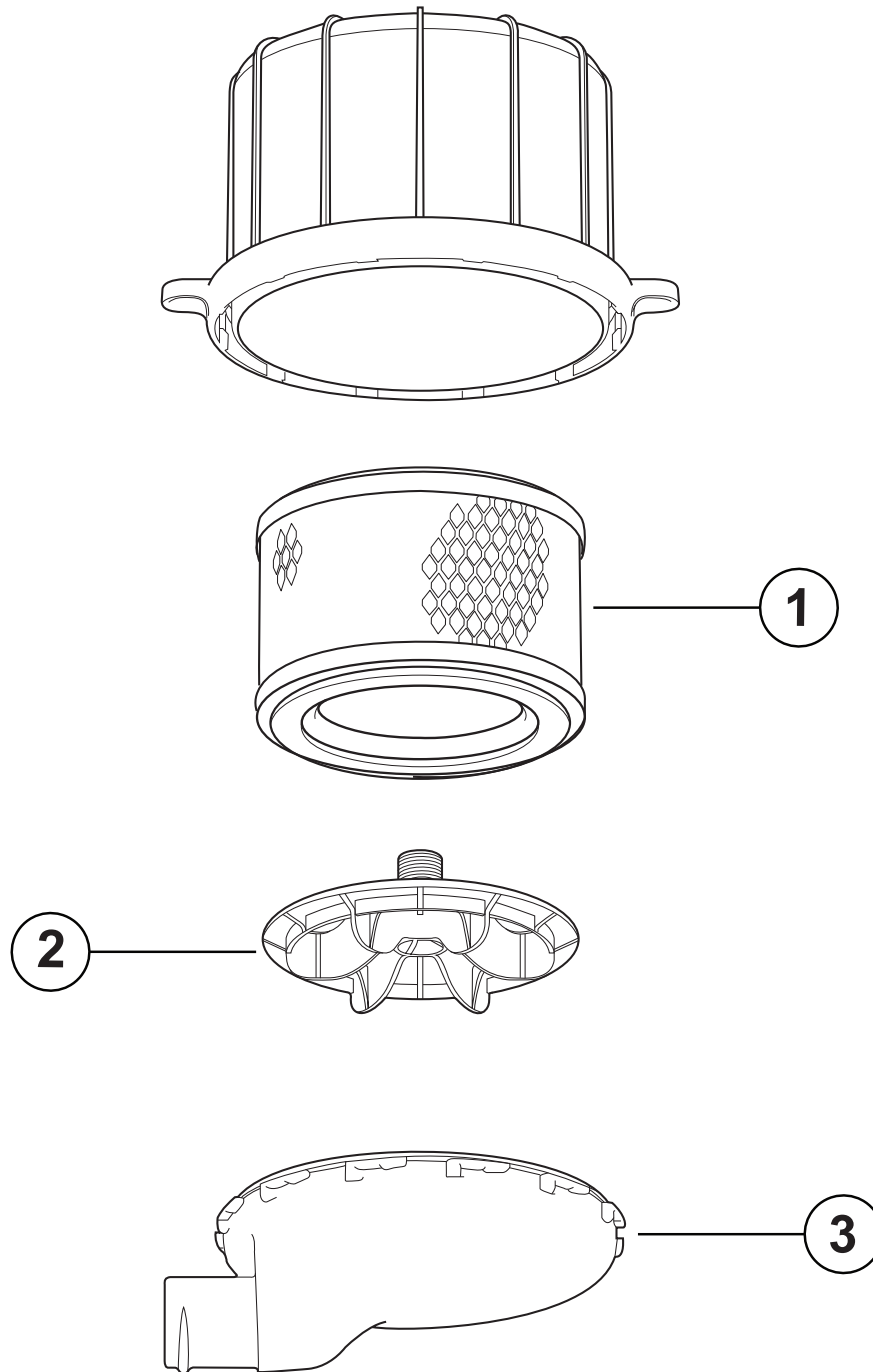

#	PART NO.	PART DESCRIPTION
1	HEPA	HEPA FILTER
2	FKEEP2	HEPA FILTER KEEPER
3	HCOVER	HEPA COVER





kaivac cleaning systems™

Don't just clean it. Kaivac it.™

Contact Us

Denis Rawlins Ltd. 17 Maybrook, Sutton Coldfield. B76 1AL

T: 0121 351 4444 **E:** sales@rawlins.co.uk **W:** www.rawlins.co.uk

