

LAPLACE INSTRUMENTS LTD

RF300

**Large Loop Antenna
(Van Leen Loop)
2 metre diameter**

Mk II-A

USER MANUAL
Ver 2.00 October 2011

Serial number: XXXX

Distributed by:
Reliant EMC LLC
3311 Lewis Ave
Signal Hill CA 90755
408-916-5750
www.reliantemc.com

This Page intentionally blank

Index

- 1.0 Introduction
- 2.0 Packing List
- 3.0 Assembly
- 4.0 Calibration loop
- 5.0 Calibration
- 6.0 Operation

Appendix

- A. Calibration data
- B. Latest changes to standards
CISPR15 & CISPR16.

This Page intentionally blank

1.0 Introduction

The RF300 large loop antenna has been developed to meet the requirements of EN55015: 2006 + A2: 2009, section 9.9.1, which refers to CISPR16-1-4: 2007 + A1: 2008 section 4.6.1. This specifies the limits for magnetic field induced current for luminaires with lamp operating frequencies in excess of 100Hz.

Construction of the RF300 is as detailed in annex C of EN55016. This antenna is fully compliant with the standard and details of the calibration factors are included in this manual. These antenna factors should be added to the results to obtain correct measurements that can be compared directly with the limits.

Test setup and limits should be conducted as required by EN55015, section 4.4.

The design of the RF300 is such that it can be readily erected and provide a rigid and stable configuration for accurate and repeatable measurements.

A calibration loop (RF300C) is available as an option if on-site calibration is deemed necessary. The RF300C allows the calibration loop to be used on all three axes and rotated within each as required by the standards.

2.0 Packing List

On receipt of the RF300, check the contents of the packages against the diagram shown in fig 1.

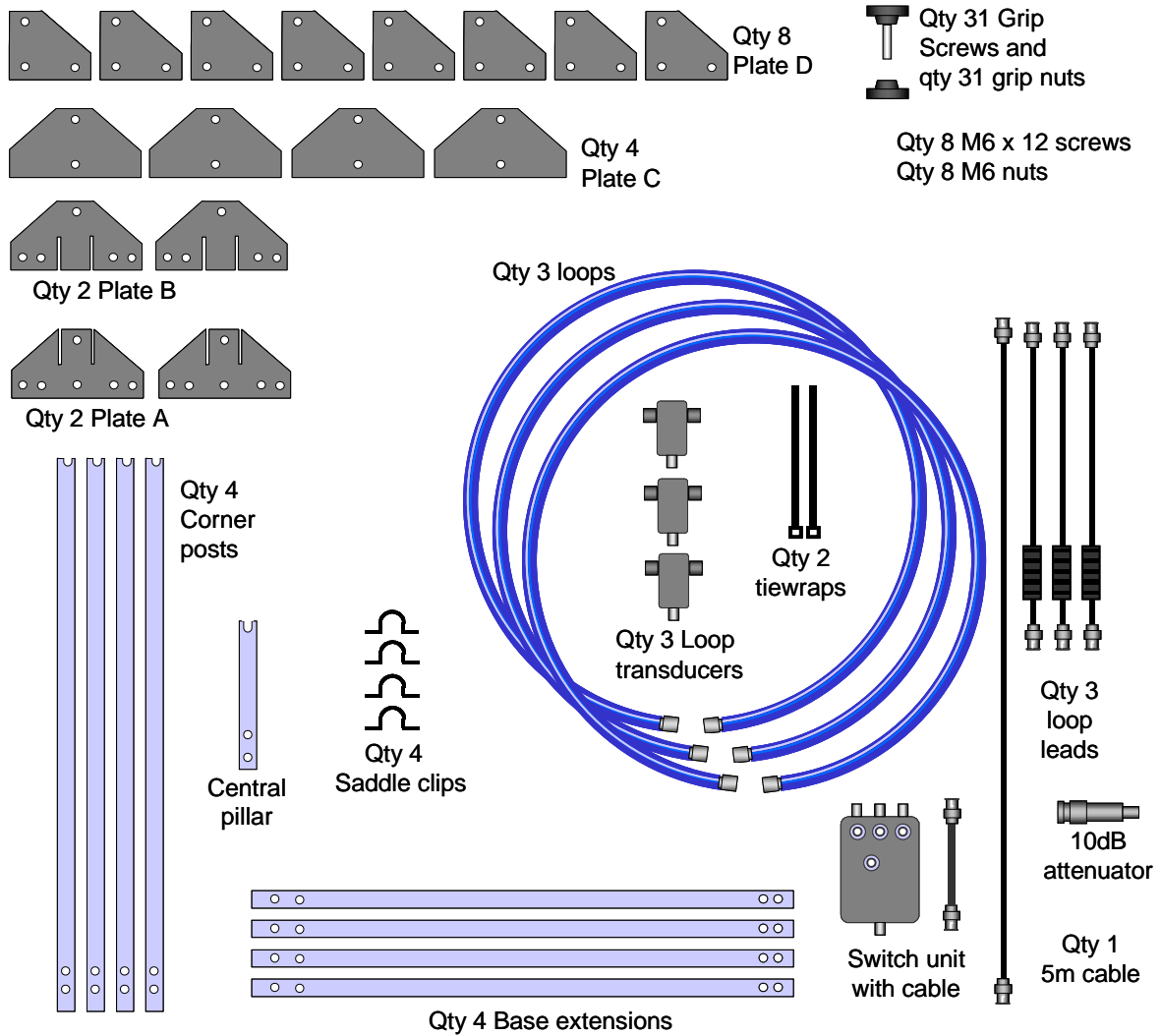

Identify each component and check for shortages.

Quantity	Item
2	Plates A
2	Plates B
4	Plates C
8	Plates D
3	Loop antennas (Blue)
4	Corner posts
4	Base extensions
1	Central pillar
4	Saddle Clips
31	Grip screws (M10)
31	Grip nuts (M10)
8	M6 x 12 screws and nuts
3	Loop transducers (current sensors)
1	Switch Unit
1	Short BNC—BNC cable, patch cable
1	BNC—BNC cable (5m), output cable
3	BNC—BNC cable (1.5m), loop leads
1	10dB attenuator
2	Tiewraps

3.0 Assembly

3.1 Stage 1 Central sub-assembly

Establish a clear area with a level floor clear of metallic structures and having a 3m clearance height.

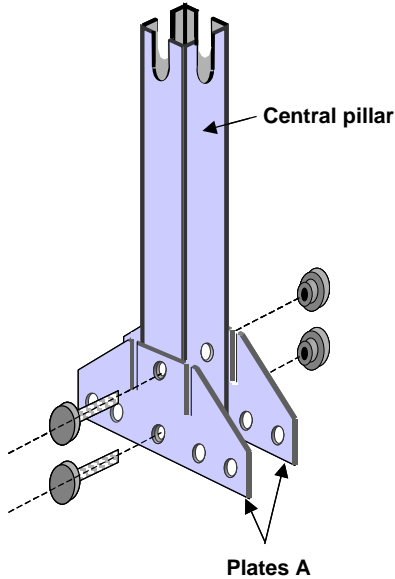

Figure 2

1(a)....Secure Plates A to the central pillar using the supplied grip screws.. Note that the plates have tapered holes to mach the taper on the grip screws, so ensure that these plates are assembled correct way round.

1(b)....Secure Plates B as shown in fig 3.

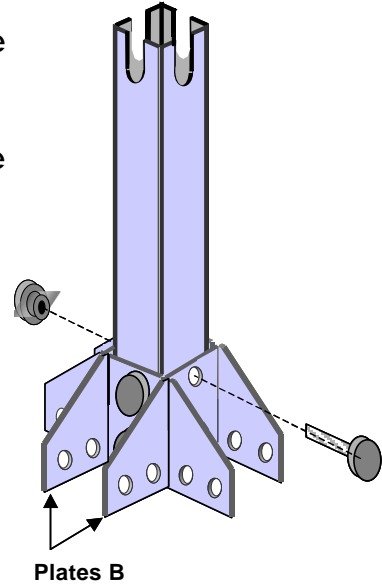

Figure 3

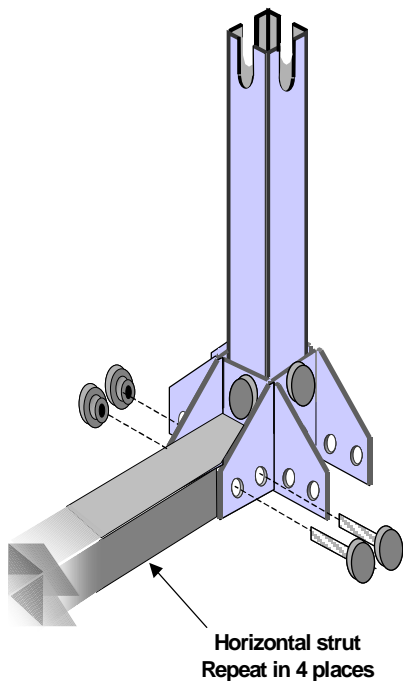

Figure 4

1(c).....Place the central post assembly in the centre of the prepared area and add the 4 base extensions, each using 2 grip screws.

3.2 Stage 2 Corner post assembly

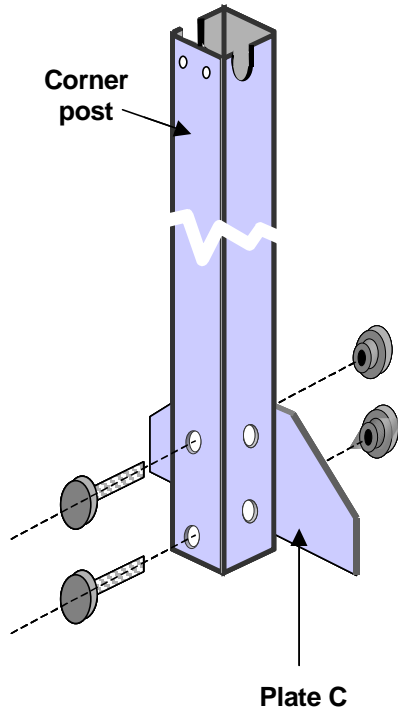

Figure 5

2(a) ...Add plate C to the base of each corner post using 2 grip screws. Repeat for the other corner posts. Note that the plate is fitted on the opposite side to the 2 mounting holes at the top of the post.

2(b)... Add the 2 Plates D to each corner post as shown. In Fig 6.

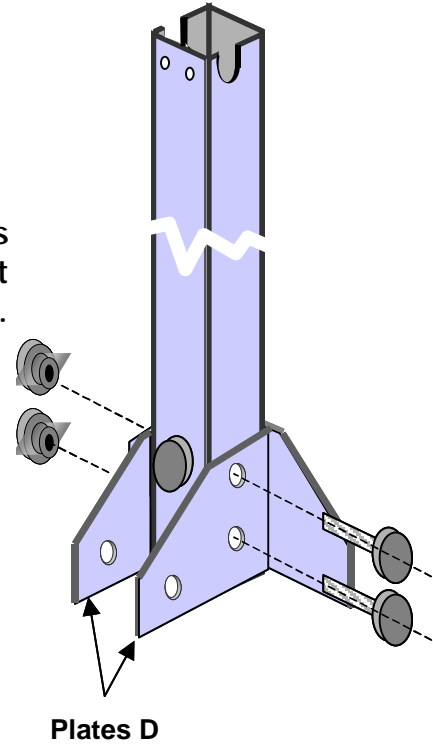

Figure 6

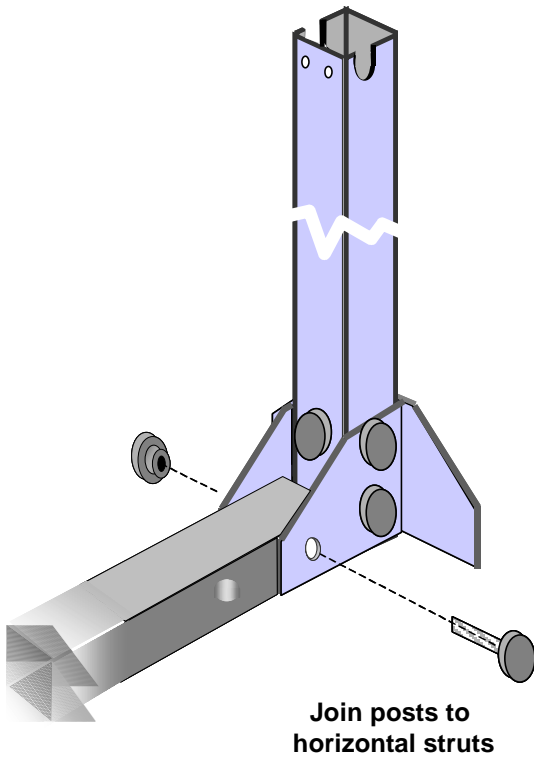

Figure 7

2(c.).....Secure the corner posts to the outer end of each base extension.

3.3 Assembly of Loops

The frame should now look like that shown in Figure 8.

The next steps are to add the loops.

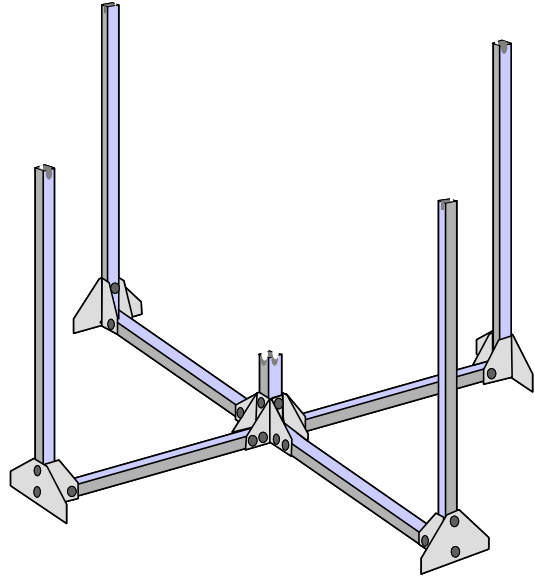

Figure 8

3.3(a) The configuration of these loops is as shown in fig 9 and fig 10. The connectors on each end of the loop are mated with the sockets either side of each loop transducer. The retaining ring on each connector needs to be screwed firmly to the socket but take care. These rings will bind and be difficult to turn unless the loop is aligned properly. Force is not necessary, simple jiggle the loop into alignment and the ring will turn easily.

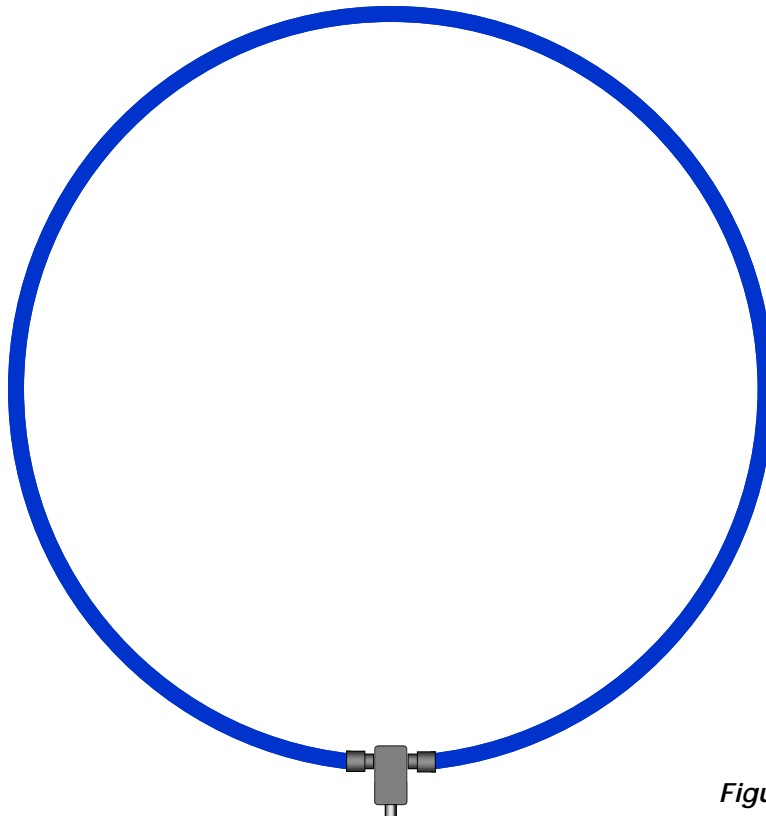

Figure 9

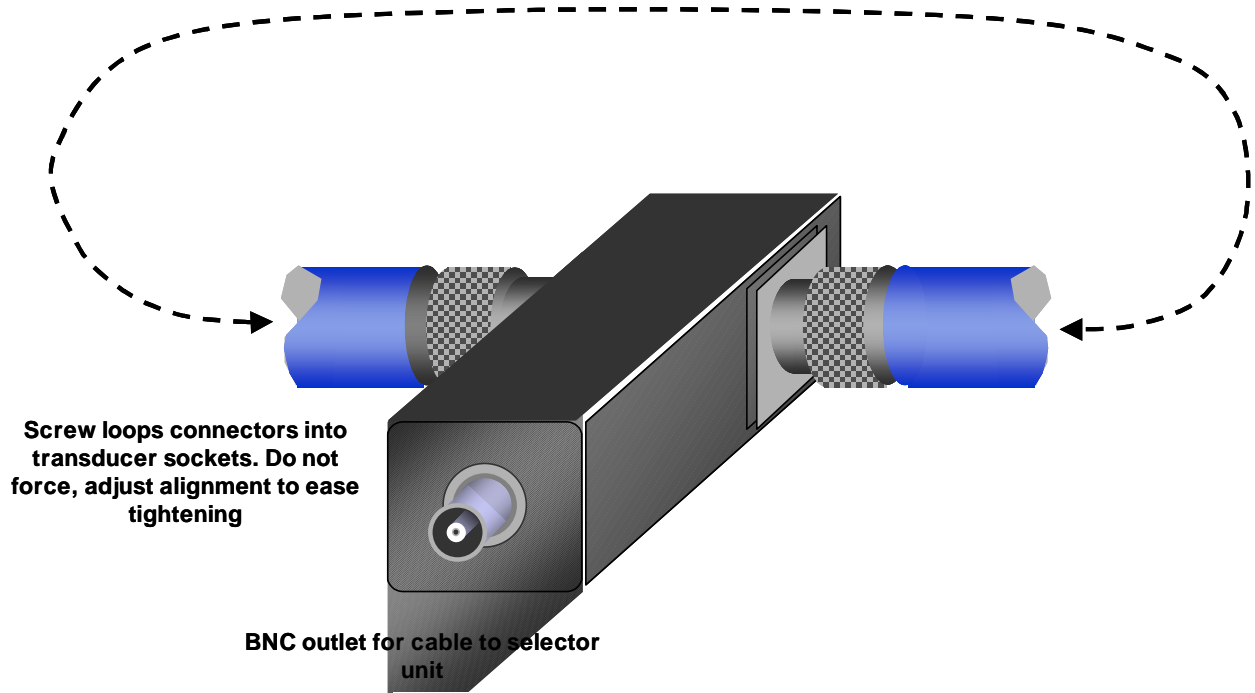

Figure 10

3.3(b) Install the first loop on the stand. This is the horizontal orientation. This task requires at least 2 persons. The loop will simply rest in the slots at the top of the corner posts. Locate the current transducer close to one of the corner posts. It will be found that if the loop does not lie flat, by rotating it relative to the stand, and/or inverting it, an optimum position can be found which results in the 'flatest' loop. Note that there is no requirement for a perfectly flat loop. Some vertical displacement round the loop will not affect results.

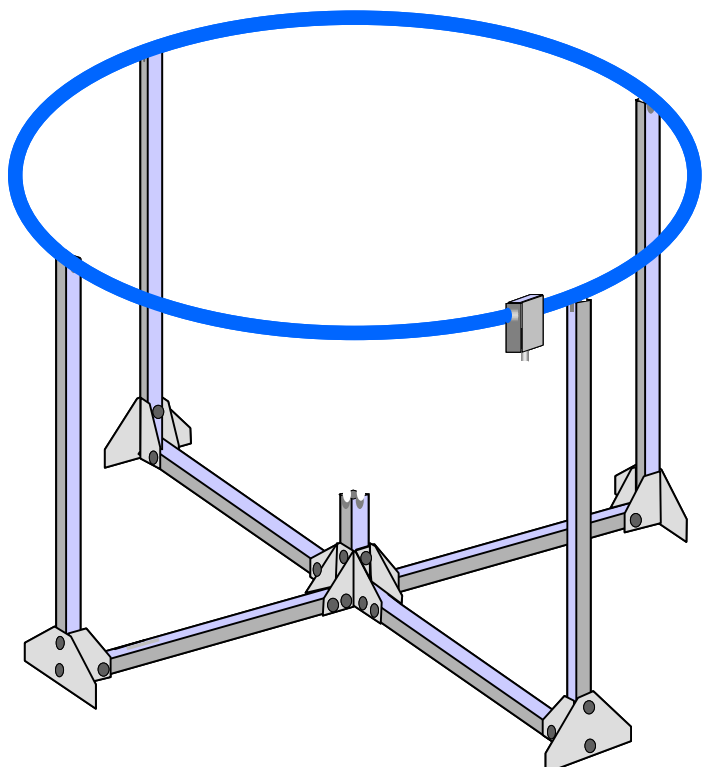
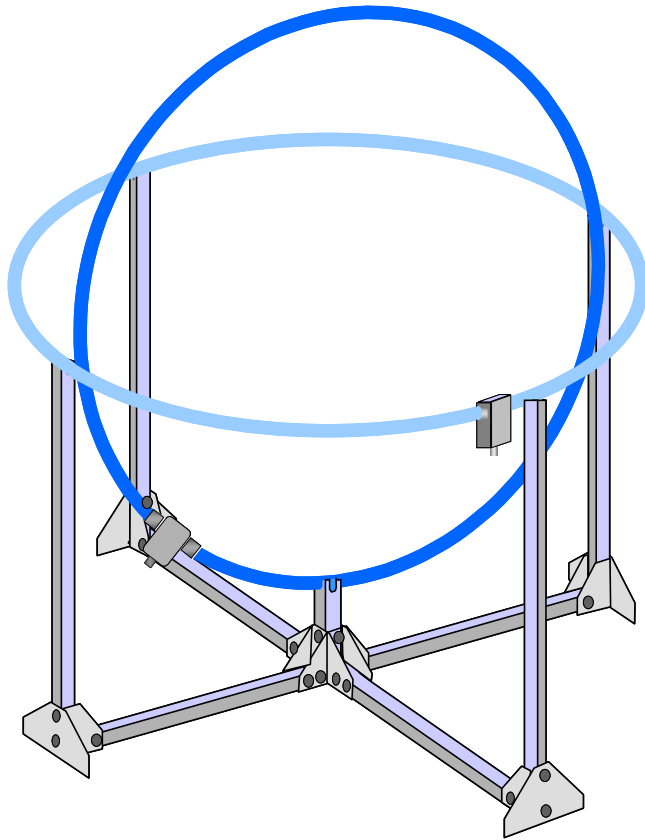

Figure 11

Figure 12



3.3(c.) The second loop is now fitted. Figs 12 and 13 show the details.

This loop is fitted inside the first (horizontal) loop, orientated so that it fits in the lower 'slot' in the central pillar and is held by the saddle clips at the top of the corner posts (fig 13).

Arrange the loop so that the transducer is within 20 cm of the central pillar.

Adjust the position of the loop in the saddle clips to give best circular shape of the loop.

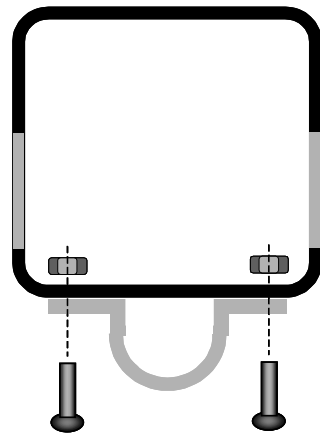

M6 x 12 screws
and M6 nuts

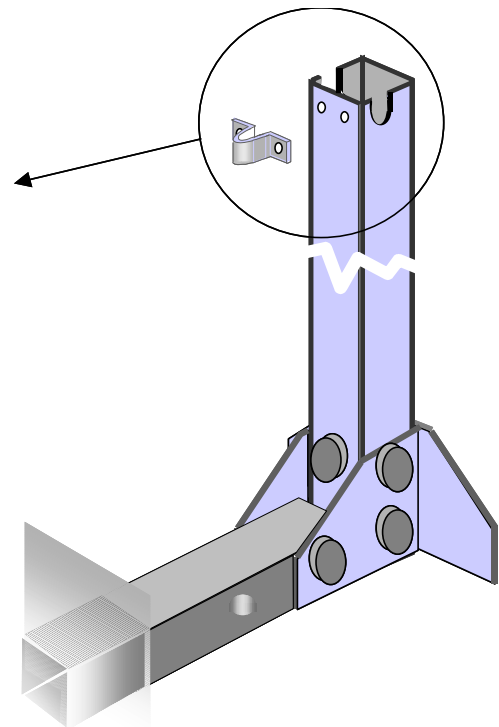

Figure 13

3.3 (d). The final loop is now fitted **INSIDE** the other two. See fig 14.

This fits in the upper slot in the central pillar and under the other vertical loop at the top. Again arrange the loop so the transducer is close to the central pillar.

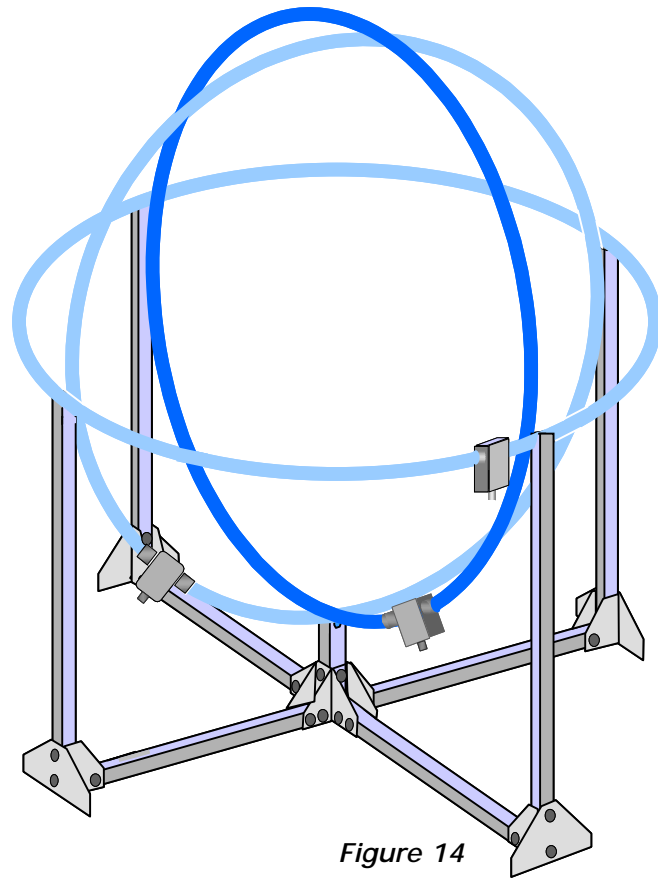

Figure 14

3.3(e). The loops can now be adjusted for best shape and position. Generally the vertical loops will tend to sag into the lower half of the antenna. These are held up in position by using the saddle clips on each corner post to take some on the weight of the loop.

The top of the vertical loops can be adjusted for best shape and the two loops fastened together with the tiwraps as shown in fig 15. With care, the tiwraps can be adjusted to produce reasonable circles for each loop.

Note that the exact shape is not critical. Deviation from perfect circles is inevitable but this has no significant effect on antenna performance.

EN55015 states in section 7.2 that even the position of the UUT in the antenna is not critical.

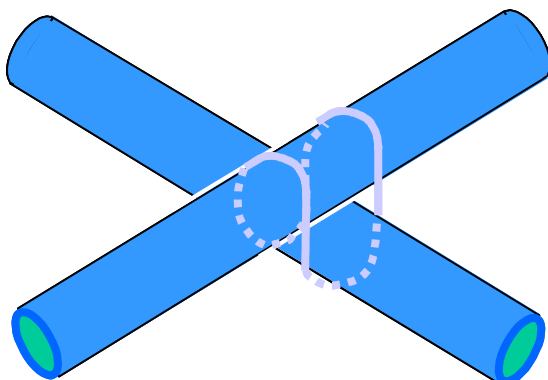

Figure 15
Arrangement at top of loops.
Use 2 tiwraps in series for adequate length.

3.4 Mounting the EUT

Within the loop, construct a wooden stand or table to suit the products to be tested. This is not included with the RF300 because it needs to be matched to individual customers requirements. The stand should hold the product roughly central within the loop.

3.5 Connections

Connect the loop transducers to the switch unit as shown in fig 16. The 3 transducer cables are identified by having thick RF absorber filters along their length. Fit the cables so that these filters are nearest to the switch unit.

The switch unit is intended for floor mounting, or may be mounted on a suitable table if preferred. The short co-ax cable acts as a patch cable to switch each input, one at a time, to the output.

The output from the switch unit is connected direct to the analyser or receiver.

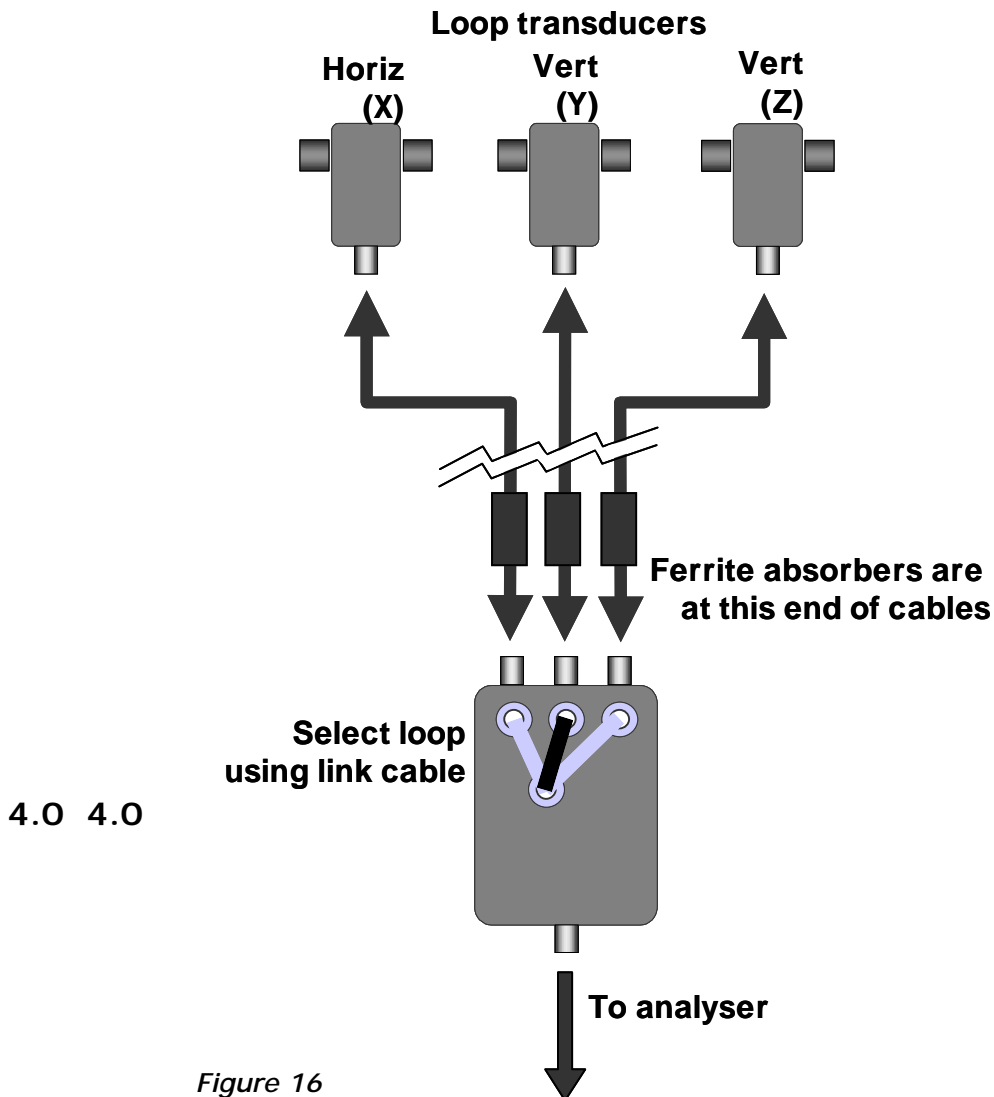

Figure 16

4.0 Calibration loop (RF300C)

The RF300C calibration loop is manufactured to comply with CISPR16.

Full details of the use of this loop are provided in this standard.

This item (RF300C) is available as a separate option to go with the RF300 LLA. The RF300 is supplied fully calibrated but the calibration loop is available to those who wish to check the calibration at regular intervals, and to ensure that the calibration is not affected by the environment.

4.1 Shipping list

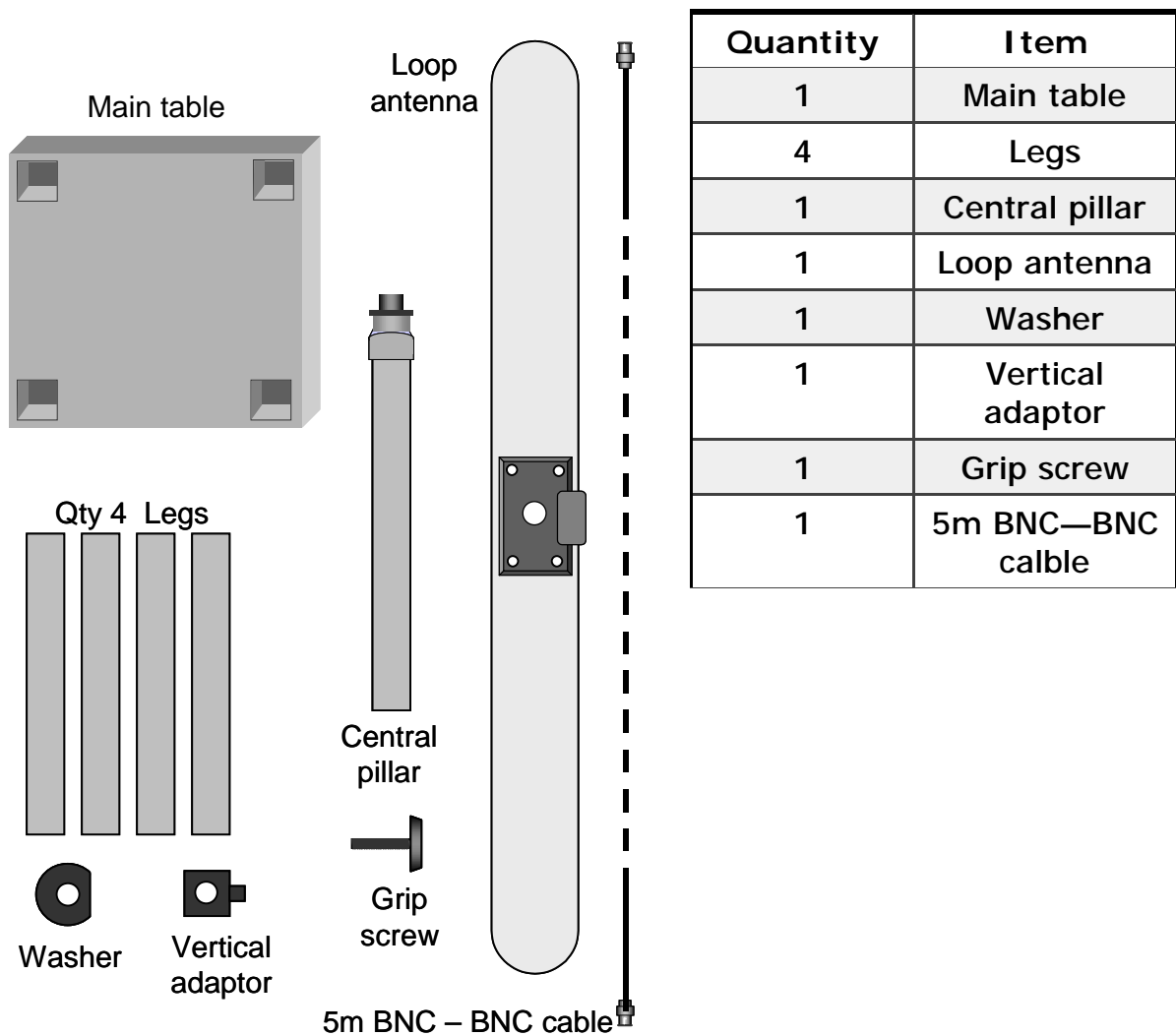

Figure 17

4.2 Assembly

Mount the table on the 4 legs. These just slot into the recess on the underside of the table.

Locate the table in the centre of the RF300, with the centre in line with the central pillar of the LLA.

Slot the central pillar of the calibration assembly into the hole in the centre of the table.

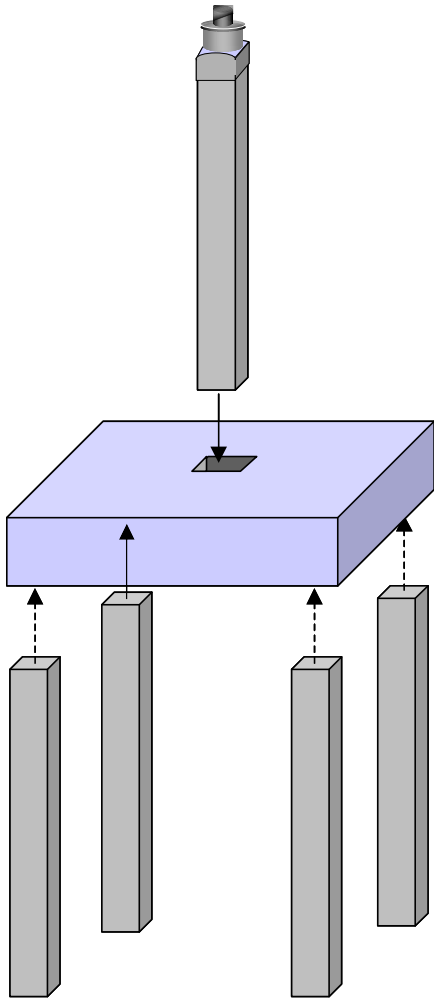

Figure 18

The assembly should now be as shown in fig 19

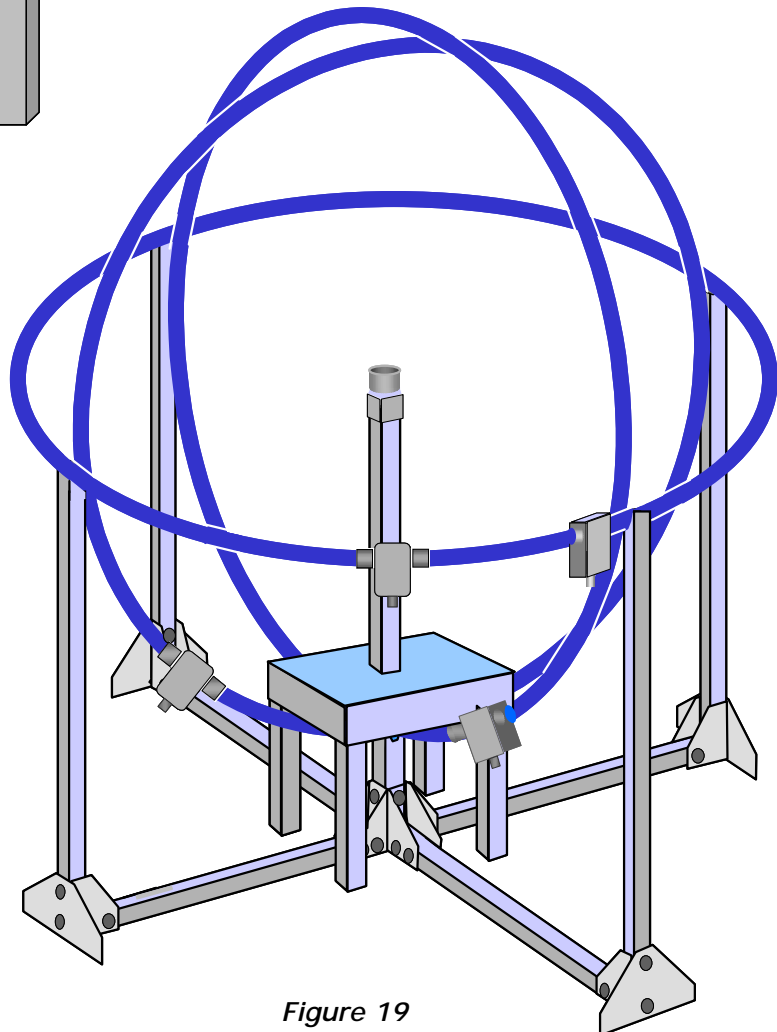

Figure 19

4.3(a) Horizontal axis

Locate the washer over the top spigot on the central pillar, then locate the loop antenna on this top spigot.

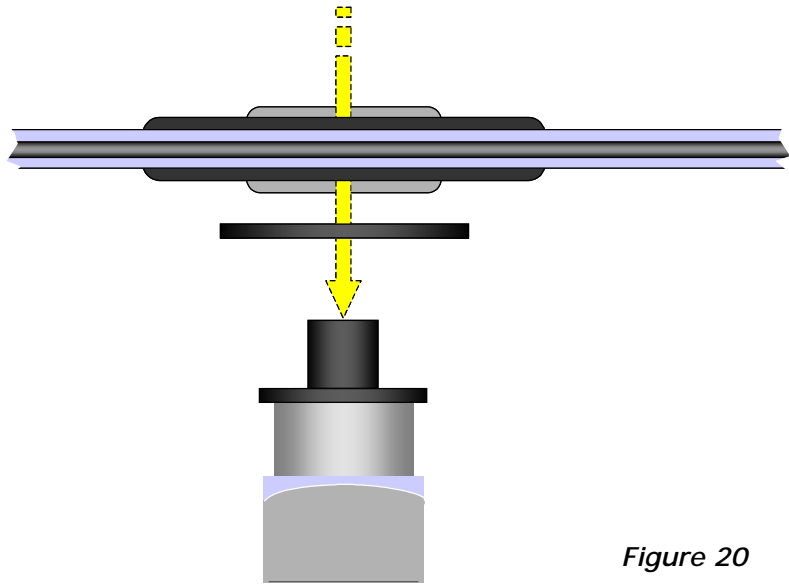

Figure 20

4.3(b) Vertical axis

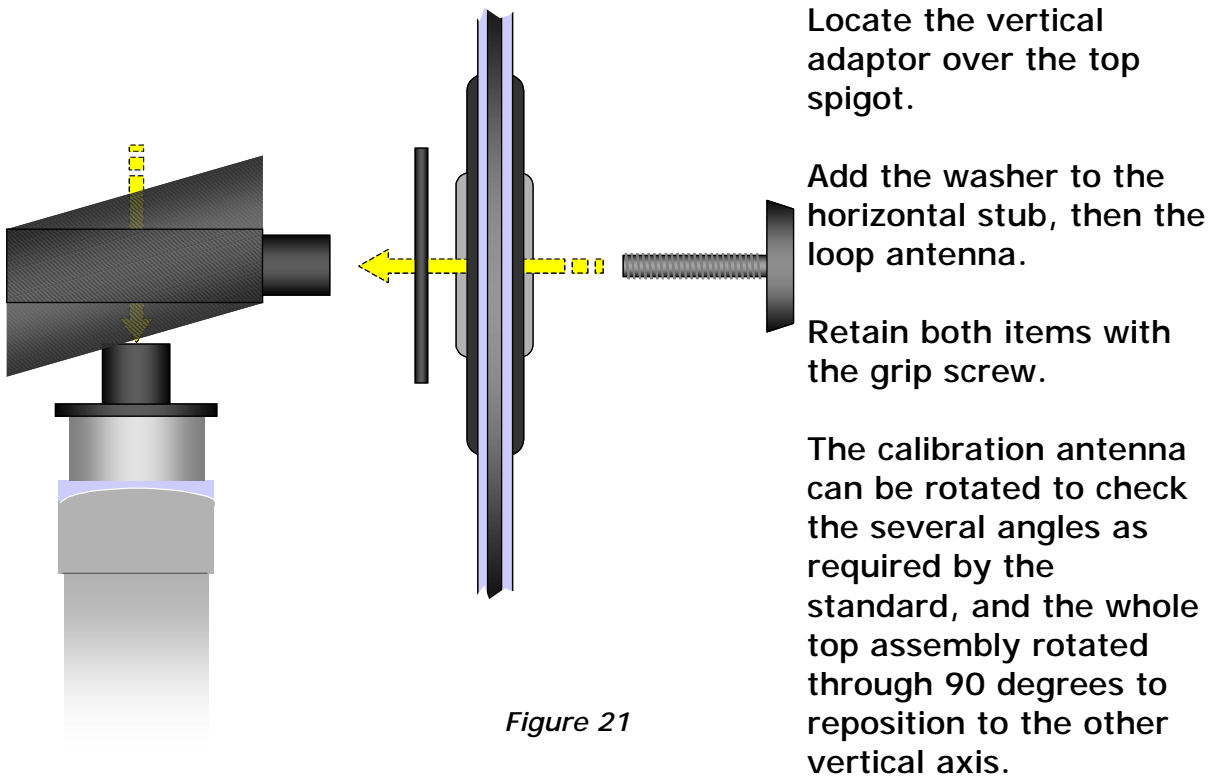

Figure 21

5.0 Calibration

The calibration technique is fully described in CISPR16. It requires the use of a signal generator covering the range 9KHz to 30MHz with a 50ohm output that is calibrated for 1v rms emf.

See appendix A

The calibration data for each loop is virtually identical. The following details therefore apply to all three axes, although full data for each axis is given in the appendix.

For reference, the 'ideal' curve is shown in graph 1. This is taken directly from EN55016, annex C, Figure C8.

The antenna factor data for the RF300 are also given.

This 'antenna factor' correction data effectively converts the output from the RF300 (measured in dBuV) directly to dBuA.

The data can be used with any analyser or receiver capable of EMC measurements.

The estimated measurement uncertainty is 3dB.

For a detailed explanation of the calibration of the RF300 and discussion of changes to CISPR15 (EN55015) and CISPR16, see appendix B

If using the SA1002 or SA3000 analyser:

The RF300 is listed under the normal Inputs menu. Just select this device and the software automatically applies the appropriate correction factors so that the trace reads correctly in dBuA and can be compared directly with the EN55015 limits.

Further details are given in section 6.1

6.0 Operation

Details of the measurements and limits are given in EN55015, section 4.4. A copy of this should be consulted if performing compliance tests.

The UUT should be mounted on a wooden frame or table in the centre of the antenna. The position is not critical.

Connecting cables to the EUT should leave the volume enclosed by the loops in such a way as to be kept away from the loops to avoid capacitive coupling. See Fig C6 in CISPR16.

Each axis (loop) should be measured in turn. Each should meet the requirements of the standard. The loops are individually selected by connecting the short patch lead to the appropriate input socket as shown in fig 11.

6.1 Measurement with the SA1002 or SA3000 and EMC Engineer Windows software.

1. Select the RF300 item under the input menu. The vertical scale will indicate units of dBuA. (If this item is not available, you need a later version of the software. Contact your supplier)
2. Under the limits menu, select the EN55015 2m loop antenna limit line.
3. Connect the switch unit to the analyser input.
4. With the UUT switched off, check the background signal level. At frequencies below 1MHz, the background can be very strong. If strong signals do exist, check that the analyser is not in compression by changing the input attenuator setting on the analyser and comparing scans. Apart from the base line, the traces should overlay. If this happens then it is OK to use the analyser with that attenuator setting. If not, increase the attenuation and try again.
5. If the background is strong, it is advisable to either find a 'quieter' location or screen the room.
6. Switch the UUT on. Check the levels of signal over the background levels using the techniques used for conventional radiated testing as described in the user guide.
The levels displayed are fully compensated for the RF300 characteristics

and can be compared directly with the limit lines.

7. ALWAYS check for compression (overload) when taking measurements. The amplitude of the reading on the screen cannot be used directly as a guide for compression because the readings have been adjusted for the RF300 characteristics.

If it is suspected that the signals are too strong even with the attenuator switched in, install the 10dB attenuator in the input lead to the switch unit. This additional attenuator can be automatically compensated for in the software by adjusting the pre-amp settings on the screen.

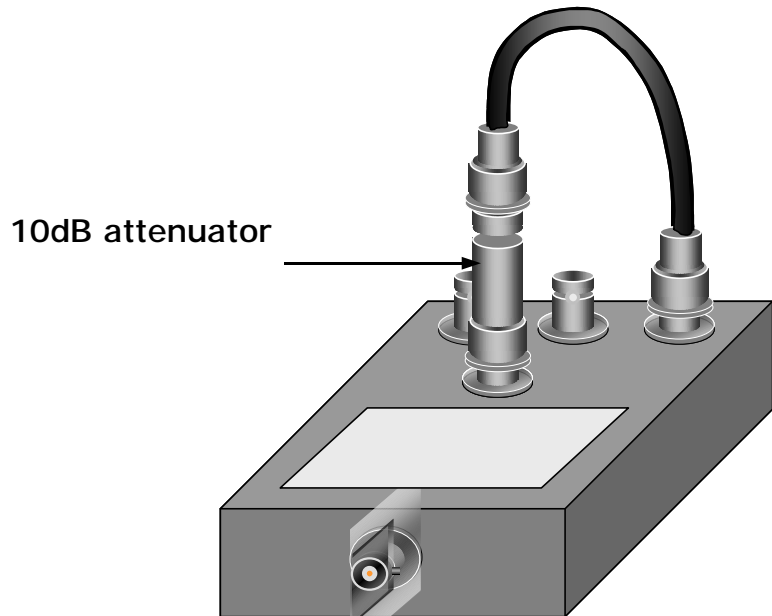

Figure 22

8. If the background and the product is 'quiet', and especially at frequencies above 20MHz, use 0dB attenuation.

APPENDIX A

CALIBRATION DATA

1. CISPR16 'ideal' plot
2. Calibration data.
3. RF300 actual sensitivity plots and RF300 correction plot (Antenna Factor)

This Page intentionally blank

EN55015 Standard antenna response

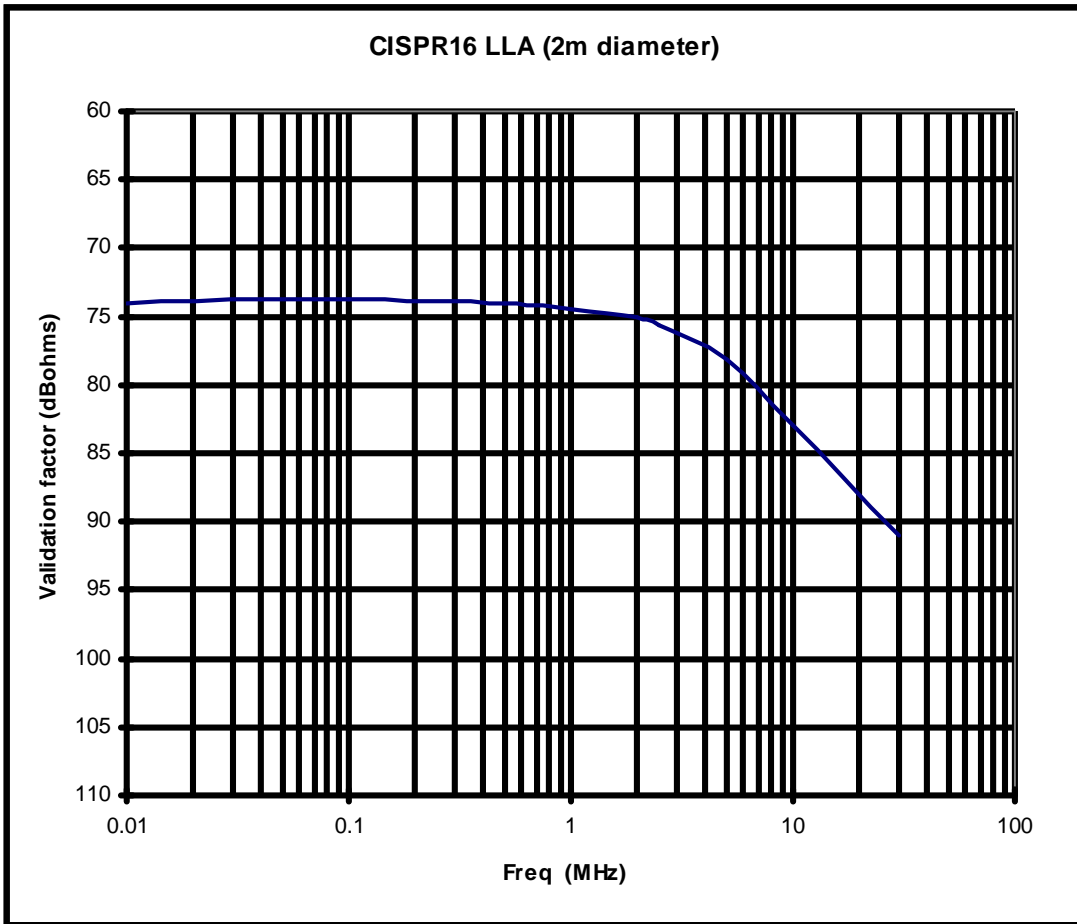

This Page intentionally blank

Laplace Instruments Ltd

Calibration data

Freq.	Calibration			Freq.						EN		
MHz	9108A	9108B	9108C	MHz	Average	Max	Min	Range	Freq	55015	Freq	A.F
0.01	37.00	35.00	36.00	0.01	36.00	37.00	35.00	2.00	0.01	46	0.01	10.00
0.04	48.00	48.00	48.00	0.04	48.00	48.00	48.00	0.00	0.04	46.5	0.04	-1.50
0.10	57.00	57.00	57.00	0.10	57.00	57.00	57.00	0.00	0.10	46.5	0.10	-10.50
0.50	68.00	67.00	68.00	0.50	67.67	68.00	67.00	1.00	0.50	46	0.50	-21.67
1.00	71.00	71.00	71.00	1.00	71.00	71.00	71.00	0.00	1.00	45.5	1.00	-25.50
2.51	72.00	72.00	72.00	2.51	72.00	72.00	72.00	0.00	2.51	44	2.51	-28.00
5.04	69.00	69.00	69.00	5.04	69.00	69.00	69.00	0.00	5.04	41	5.04	-28.00
10.01	64.00	64.00	64.00	10.01	64.00	64.00	64.00	0.00	10.01	37.5	10.01	-26.50
12.00	63.00	63.00	63.00	12.00	63.00	63.00	63.00	0.00	12.00	37	12.00	-26.00
15.09	61.00	60.00	60.00	15.09	60.33	61.00	60.00	1.00	15.09	36.5	15.09	-23.83
20.09	56.00	56.00	56.00	20.09	56.00	56.00	56.00	0.00	20.09	36	20.09	-20.00
25.03	55.00	55.00	55.00	25.03	55.00	55.00	55.00	0.00	25.03	35.5	25.03	-19.50
30.00	52.00	52.00	52.00	30.00	52.00	52.00	52.00	0.00	30.00	35	30.00	-17.00

Calibration sources

Laplace Instruments Ltd, RF300C calibration loop to CISPR16, annex C5.

Laplace Instruments Ltd, SA1002 Spectrum analyser s/n 1010
Calibration: Laplace: 16.03.2009

Marconi TF2016A signal generator, s/n 118032/004
Calibration: Checked against Marconi TF2019A, s/n 118449-169

Advantest R4131D calibrated by Schaffner, 20.11.02 and checked against
Marconi TF2019A, s/n 118449-169

Marconi TF2019A, serial number 118449-169, calibrated by Industrial
Calibration Ltd, 22.06.07

This Page intentionally blank

Appendix B

Actual output plots for the loops

Output

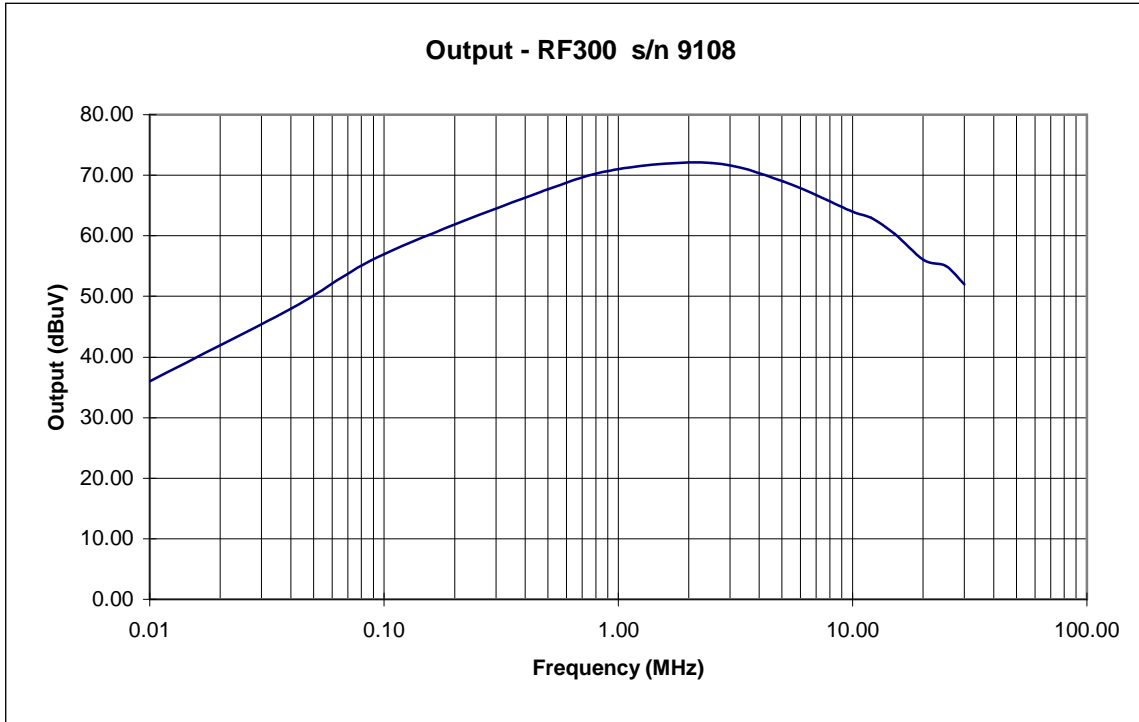

Antenna factor

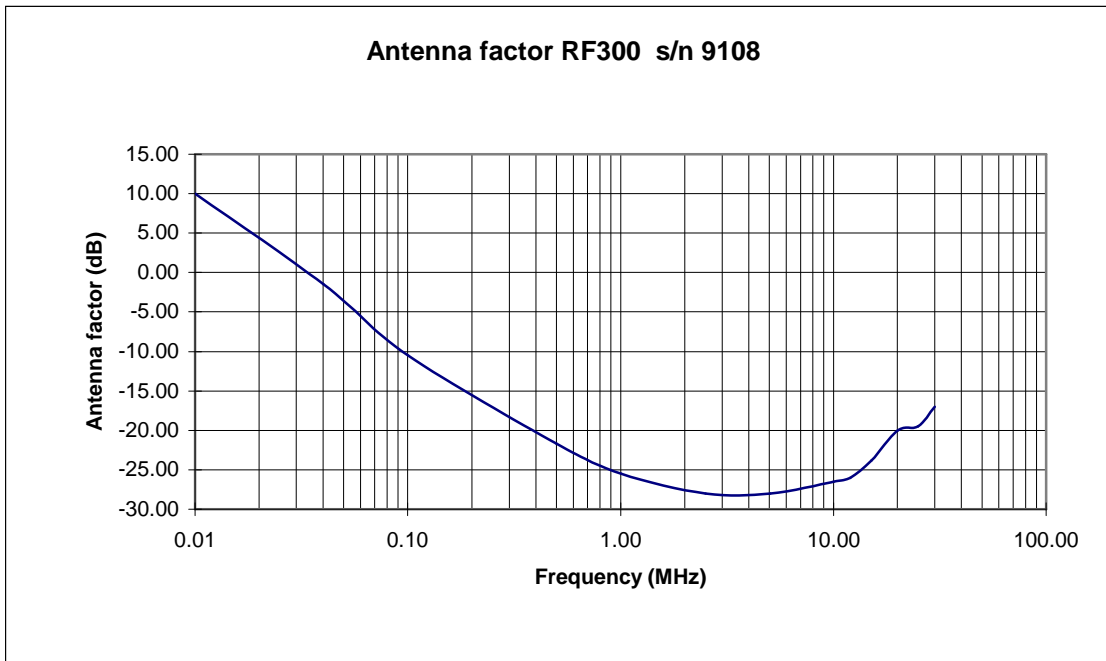

Appendix B

Changes to standards CISPR15 and CISPR16, 2009

RF300 Large loop antenna, an analysis of changes to the standards

These changes are due to the amendments to CISPR15 and CISPR16

The latest versions are now

CISPR15:2006 + A2:2009 and

CISPR16-1-4:2007 + A1:2008

The key changes related to LLAs are:

1. Sections related to the construction and specification of LLAs are moved from CISPR15 to CISPR16. Note that in the new CISPR15, the requirements for the LLA are referred to Section 4.7.1 in the new CISPR16, which does not exist! It seems that the reference should be to Section 4.6.1. The same error is repeated in CISPR16 which again refers in Annex C to the non-existent section 4.7.
2. The definition of the calibration data has been re-defined.

Previous CISPR15	New CISPR16	Notes	Significant changes
Annex B	Annex C	Description, construction and validation of LAS	Both annexes combined into one.
Annex C			
Clause B1	Clause C1	Introduction	Loop antenna named LAS (Loop Antenna System)
Clause B2	Clause C2	Construction of LAS	Additional requirements for cables and connectors.
	Clause C3	Construction of loop	Information previously included with diagrams now included in text. Note low R for inner conductor is required.
Clause B3	-----	Positioning of the LAS	Requirement for minimum distance to nearby objects,..... not included in new CISPR16
Clause B4	Clause C4	Validation	New definition for validation factor. (see below).
Figure B1	Figure C1	General view	None
Figure B2	Figure C2	Position of slits	None
	Figure C3	Construction of slits	None
	Figure C5	Metal box for current probe	None
Figure B3	Figure C4	Example slit construction	None
Figure B4	Figure C8	Validation factor	Converted from dBuA to dB(Ω). See below.
	Figure C7	Positions of calibration loop	None
	Figure C9	Construction of calibration loop	None
Figure C1	Figure C11	Sensitivity vs diameter	None
Figure C2	Figure C10	Conversion factors between loop current and magnetic field strength at a distance.	Factors for magnetic field with electric field added. Factors for distance 30m removed.

Note 1.

The details of the LLA were given in Annex B of CISPR15. These are now transferred to Annex C of CISPR16. Most of the content has remained the same, but Table 1 summarises the changes.

Note 2

CISPR15 gave the verification data as a plot of loop current in dBuA vs frequency for the standard test signal (1V, open circuit voltage with a source impedance of 50ohm). This seems to be a straightforward method, especially as the limits are quoted in dBuA, so it's a direct correlation between the calibration loop and the limits.

CISPR16 is essentially the same information, but presented differently. It specifies the relationship between the source voltage (1V, as specified above) and the output current in the loop as measured by the current probe. Note that the current probe has a transfer characteristic of 1V/A. The relationship between volts and current is ohms, hence the use of dB(ohms) as the 'validation factor'.

The result is therefore a conversion factor scaled in dB(Ω) to convert current to voltage,

CISPR16 defines the validation factor $\text{dB}(\Omega) = 20 \cdot \log(V_s/I_i)$ where V_s is the source voltage and I_i is the loop current.

$$V_s = 1V = 1,000,000\mu V$$

Under 'old' CISPR15, for $I_i @ 100\text{KHz} = 46\text{dBuA} = 200\mu\text{A}$

So the new CISPR16 value is $20 \cdot \log(1000000/200) = 74 \text{ dB}(\Omega)$

and

Old CISPR15 for $I_i @ 30\text{MHz} = 29\text{dBuA} = 29\mu\text{A}$

So the new CISPR16 value is $20 \cdot \log(1000000/29) = 91 \text{ dB}(\Omega)$

These calculations confirm the relationship between the CISPR15 plot and the CISPR16 validation factor.

The plots in the standards assume a current probe with a 1V/A transfer function. Such probes are 'active' but provide a flat frequency response. The RF300 uses passive probes which have a non-flat frequency response. This is not important if the probe is 'inside' the calibration loop and has a linear transfer function with amplitude. These factors hold true for the probe that is used. So the RF300 antenna uses an antenna factor correction to produce a calibration that agrees with the validation factor. This antenna factor is supplied with each antenna, and is equivalent to the correction factors as supplied with all EMC antennas, test cells, LISNs and other types of transducer.

Using the antenna factor data with the RF300 enables the output to be compared directly with the limits as specified in EN55015.

LAPLACE INSTRUMENTS LTD

Distributed by:
Reliant EMC LLC
3311 Lewis Ave
Signal Hill CA 90755
408-916-5750
www.reliantemc.com