



DHP10Q0168

WP10系列柴油机零件图册
WP10 SERIES DIESEL PARTS CATALOGUE

潍柴动力股份有限公司
WEICHAI POWER CO., LTD.

前 言

为使WP10系列柴油机在使用、维护等工作上的方便特汇编本图册以供我方与用户在使用中查阅参考。

该图册基本上按组绘出了各个零件的图形相互关系。图序号、件号、数量、中文名称、英文名称等列于明细表栏内。

随着技术和生产的不断发展柴油机的变形将增多故本图册的内容将有所更新。变化不再另行通知特请用户注意。用户为获取最新产品信息应咨询潍柴动力股份有限公司。

FOREWORD

This illustrated parts manual is specially prepared for customers to facilitate the use of WP10 series diesel engine in operation and tenance.It only includes the main models manufactured in the works at present,with regard to other models,the customers may refer to this catalogue.

The illustrations are grouped under the heading of each assembly and numbered individually.Part.

No.,Quantity,Model,English designation,Chinese designation and so on are written in the parts list With the development of technology and production,the versions of the diesel engine will be increased, so the catalogue will be revised.Please pay attention to our revised edition.If you want to get the most newly information about the products,please visit the Website:<http://www.weichai.com>.

目 录 CONTENTS

机体结合组(Engine Block Group)	1
气缸体预装配(Pre-assembled cylinder block).....	3
正时齿轮室组件()	5
曲轴结合组(Crankshaft Group)	7
曲轴总成(Crankshaft assembly).....	9
活塞连杆结合组(Piston and Connecting Rod Group)	11
连杆总成(Connecting rod assembly).....	13
活塞环组件(Piston ring assembly).....	15
气缸盖结合组(Cylinder head assembly)	17
气缸盖分总成(Cylinder head subassembly).....	19
配气机构结合组(Valve Train Group)	21
凸轮轴总成(Camshaft assembly).....	25
EVB排气摇臂组件(EVB Exhaust Rocker Arm Set).....	27
进气门摇臂总成(Intake valve rocker arm).....	29
中间齿轮总成(Intermediate gear assembly).....	31
机油泵结合组(Oil pump assembly)	33
机油泵中间齿轮组件(Oil Pump Idle Gear Assembly).....	35
机油冷却器结合组(Oil cooler assembly)	37
共轨系统结合组()	39
电控单元组件().....	41
高压油泵结合组(High pressure pump assembly)	43
高压油管组件(High pressure pipe assembly)	45
端盖结合组()	47
油气分离器结合组(Oil-gas Separator Group)	49
油气分离器总成(Oil-gas separator assembly).....	51
油尺结合组(Dipstick Group)	53
油标尺总成(Oil dipstick assembly).....	55
加油管结合组(Oil Tilling Tube Group)	57
飞轮壳结合组(Flywheel Housing Group)	59
机油冷却器盖组件()	61

飞轮结合组(Flywheel Group)	63
曲轴皮带轮结合组(Crankshaft Pulley Group)	65
气缸盖罩组件()	67
出水管结合组(Water Outlet Pipe Group)	69
节温器结合组(Thermostat Group)	71
水泵结合组(Water pump assembly)	73
水管接头结合组(Water Pipe Connector Group)	75
风扇及轮毂结合组(Fan and Hub Group)	77
涨紧轮及皮带结合组()	79
机油集滤器结合组(Oil Suction Strainer Group)	81
机油滤清器结合组(Oil filter assembly)	83
机油滤清器总成(Oil filter assembly)	85
燃油滤清器结合组(Fuel Filter Group)	87
燃油精滤器组件()	89
精滤器(Fine filter)	91
燃油粗滤器组件()	93
燃油粗滤器(Primary fuel filter)	95
低压油管结合组(Low Pressure Oil pipe Group)	97
电控线束及传感器结合组(Electronic Control System Harness and Sensor Group)	99
电控线束及传感器结合组(Electronic Control System Harness and Sensor Group)	101
转速传感器组件()	103
机油压力传感器组件(Oil Pressure Sensor Set)	105
喷油器结合组(Injector assembly)	107
发电机结合组(Generator Group)	109
发电机支架结合组(Generator Bracket Group)	111
空调压缩机结合组(Air Conditionning Compressor Group)	113
起动机结合组(Starter Motor Group)	115
进气管结合组(Intake Manifold Group)	117
进气管总成(Air inlet pipe assembly)	119
排气管结合组(Exhaust Manifold Group)	121
增压器结合组(Turbocharger assembly)	123

增压器润滑油管结合组(Turbocharger Oil pipe Group)	125
压气机管路结合组(Compressor Pipeline Group).....	127
中冷器结合组(Intercooler assembly)	129
空压机结合组(Air Compressor Group).....	131
空压机总成(Air compressor assembly).....	133
液压泵结合组(Hydraulic Pump Group).....	135
油底壳结合组(Oil Pan Group).....	137
油底壳总成(Oil pan assembly).....	139
发动机支架结合组(Engine Bracket Group).....	141
直送零件结合组().....	143
WP多级复合沙尘滤()	145
零件箱总成(Parts Kit Assembly).....	147
16孔诊断接口插接件(方形)().....	149
双油门踏板传感器插接件(主机厂用)(Dual accelerator pedal sensor connecting part)	151
V4插接件(主机厂用)().....	153
起动机接插件总成()	155
电磁风扇线圈2插件()	157
燃油水寒宝(Fuel System Protector).....	159

机体结合组(Engine Block Group)

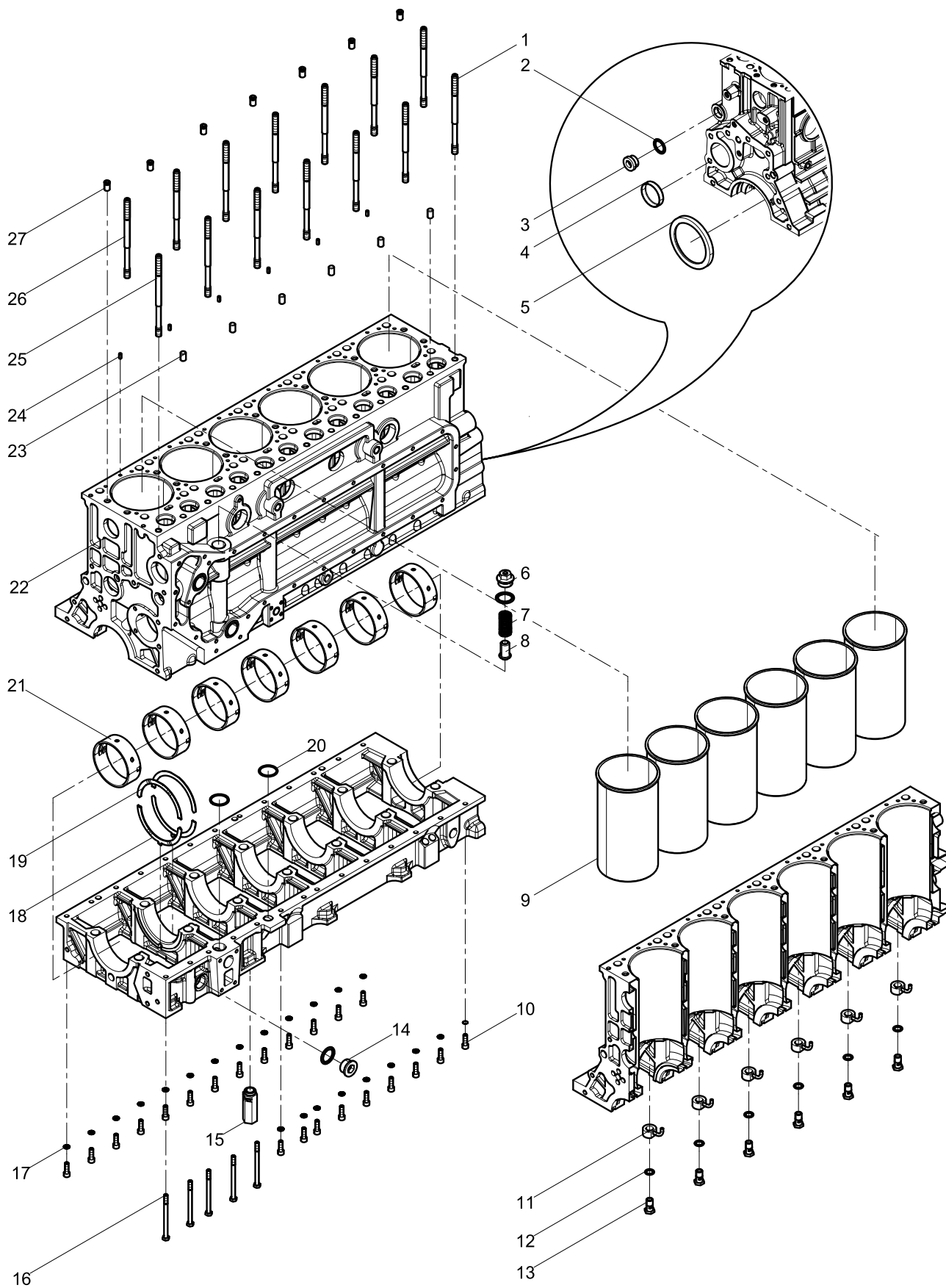

机体结合组(Engine Block Group)

图序号 Pos.	件号 Teile.Number	数量 Amount	中文名称 Denomination	英文名称 Designation
1	61500010185	6	气缸盖螺栓	Cylinder head bolt
2	612600010735	3	复合垫圈	Washer
3	61460070011	1	主油道后螺塞	Plug
4	90003989288	1	碗形塞	Corehole plug
5	61500010100	1	后油封	Rear oil seal
6	612600070160	1	六角螺塞	Hexagon plug
7	614070068	1	安全阀弹簧	Safety valve spring
8	614070069	1	安全阀	Safety valve
9	612630010015	6	气缸套	Cylinder liner
10	90003862428	22	内六角圆柱头螺钉	Inner hexagon screw
11	612600010659	6	喷嘴总成	Nozzle assembly
12	90003098015	6	密封垫圈	Seal washer
13	90003962621	6	空心螺栓	Hollow bolt
14	90003962050	1	内六角螺塞	Inner hexagon plug
15	AZ1500070097	1	主油道限压阀总成	Pressure limiting valve assembly of main oil passage
16	90003802493	5	六角头螺栓	Hexagon bolt
17	188250083	22	自锁垫圈	Washer
18	612600013918	2	下止推片	Thrust washer (lower)
19	612600013917	2	上止推片	Thrust washer (upper)
20	81400010032	2	密封圈	Seal washer
21	81500010046	7	主轴瓦组件	Main Bearing Set
22	612600013935	1	气缸体预装配	Pre-assembled cylinder block
23	90003901604	6	圆柱销	Straight pin
24	90003909626	6	弹性圆柱销	Spring dowel pin
25	612600010893	1	气缸盖螺栓	Cylinder head bolt
26	61500010185S	7	气缸盖螺栓	Cylinder head bolt
27	612600012189S	7	预涂胶紧定螺钉	

气缸体预装配(Pre-assembled cylinder block)

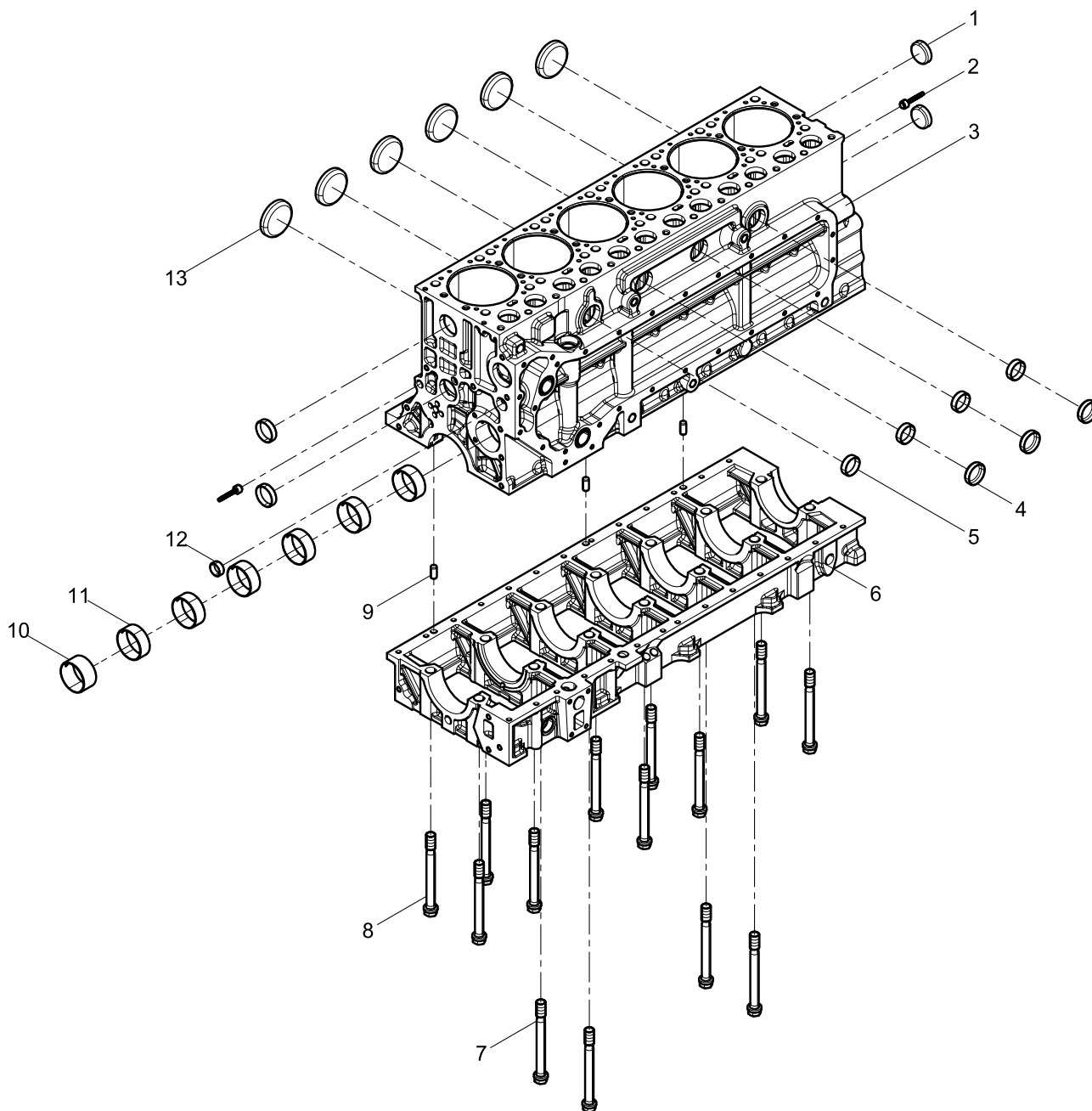

气缸体预装配(Pre-assembled cylinder block)

图序号 Pos.	件号 Teile.Number	数量 Amount	中文名称 Denomination	英文名称 Designation
1	90003982121	4	碗形塞	Corehole plug
2	612600013437	2	拉铆钉	Tensioned rivet
3	612600013747	1	气缸体	Cylinder block
4	90003989215	3	碗形塞	Corehole plug
5	90003989289	4	碗形塞	Corehole plug
6	612600013790	1	曲轴箱	Crankshaft case
7	614010217	4	主轴承螺栓	Main bearing bolt
8	614010114	10	主轴承螺栓	Main bearing bolt
9	612600010051	3	内螺纹圆柱销	Inner hexagon pin
10	612600010990	1	凸轮轴衬套	Camshaft bushing
11	61560010029	6	凸轮轴衬套	Camshaft bushing
12	90003989204	1	碗形塞	Corehole plug
13	90003989210	6	碗形塞	Corehole plug

正时齿轮室组件()

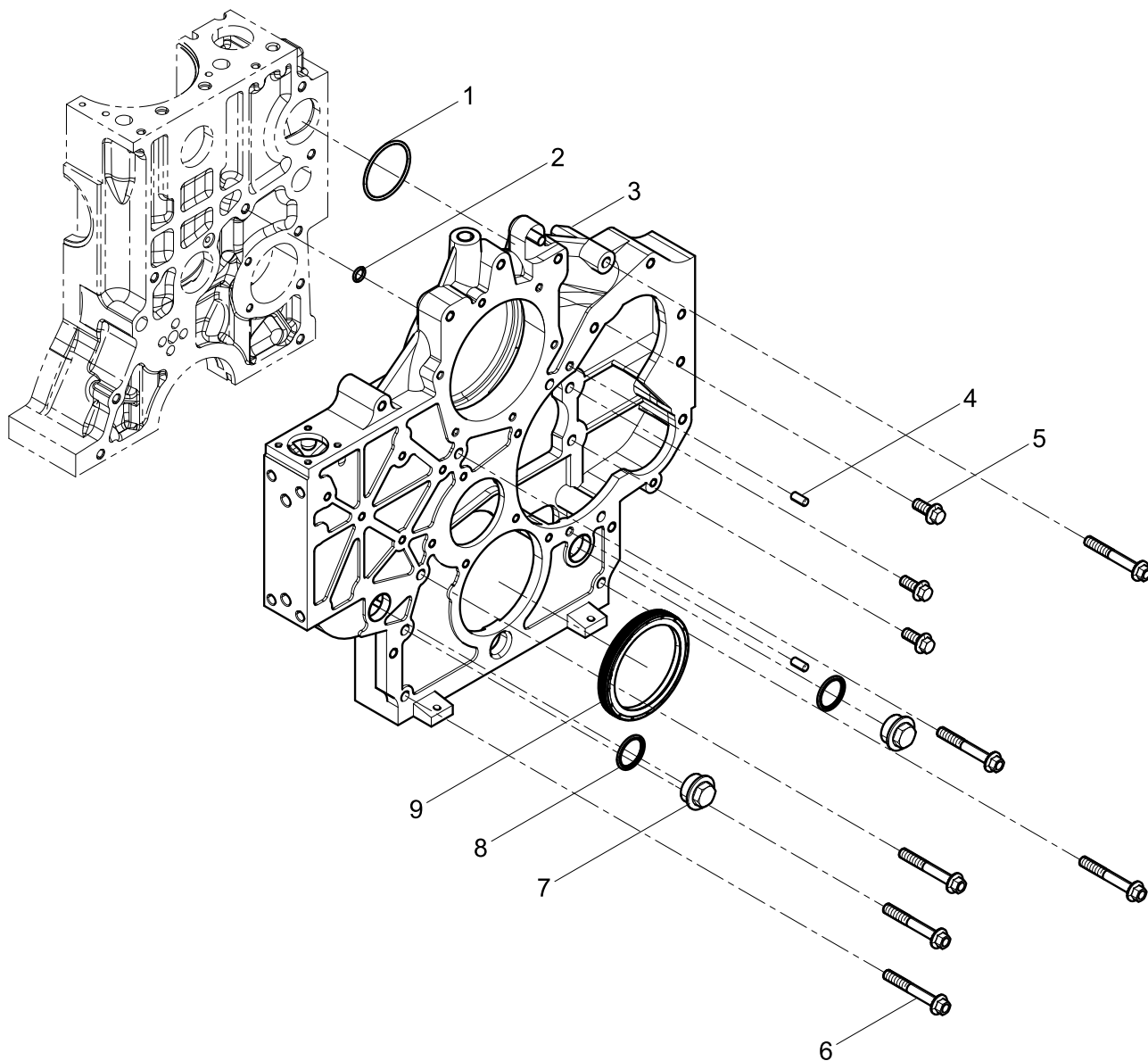

正时齿轮室组件()

图序号 Pos.	件号 Teile.Number	数量 Amount	中文名称 Denomination	英文名称 Designation
1	61000010134	1	密封圈	Seal washer
2	288730061	1	O型密封圈	O shaped seal washer
3	612600012122	1	正时齿轮室	Timing gear case
4	90003901418	2	圆柱销	Straight pin
5	90011430008	3	六角法兰面承面带齿螺栓	Hexagon Flange Bolt
6	612600013483	6	六角法兰面承面带齿螺栓	Hexagon Flange Bolt
7	90003962051	2	六角螺塞	Hexagon plug
8	612600010735	2	复合垫圈	Washer
9	61500010037	1	前油封	Oil seal(front)

曲轴结合组(Crankshaft Group)

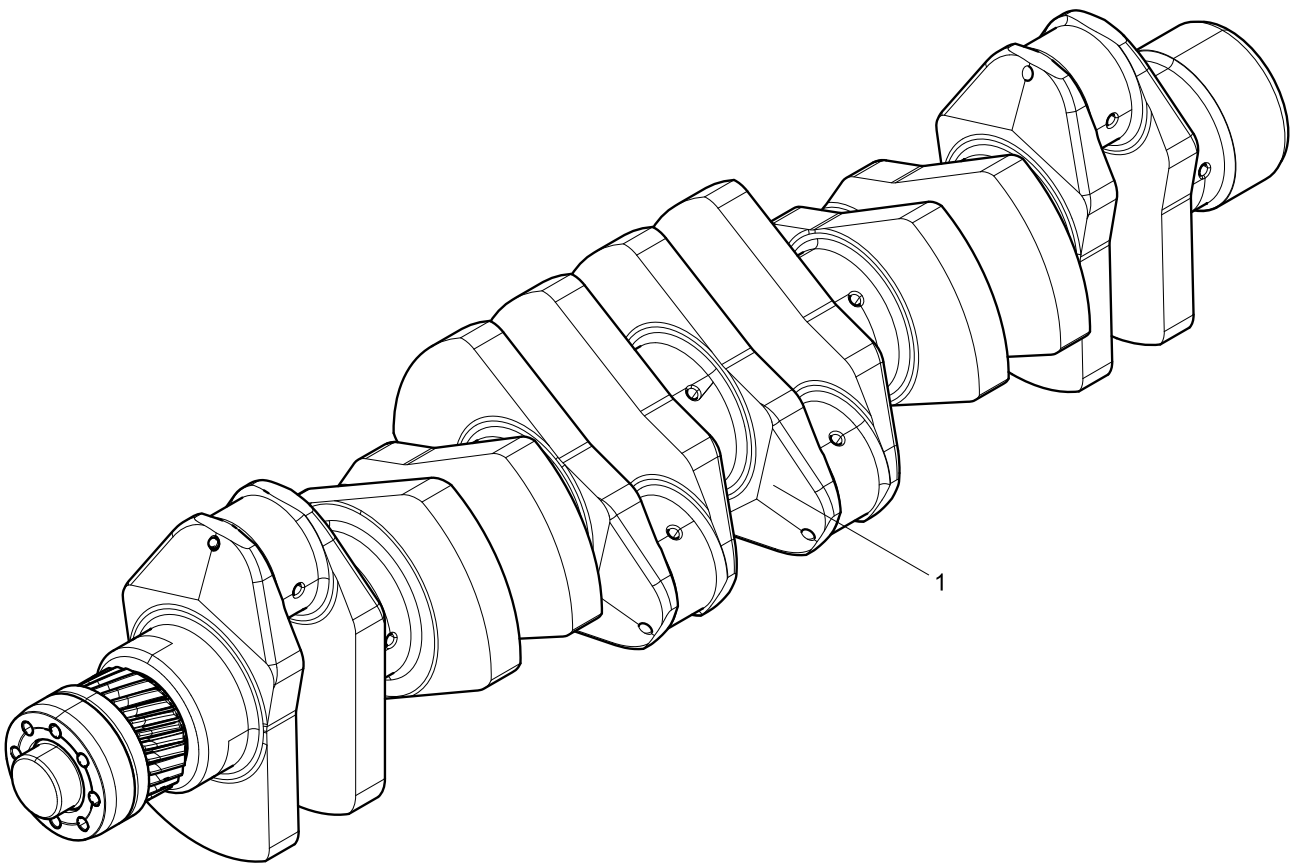

曲轴总成(Crankshaft assembly)

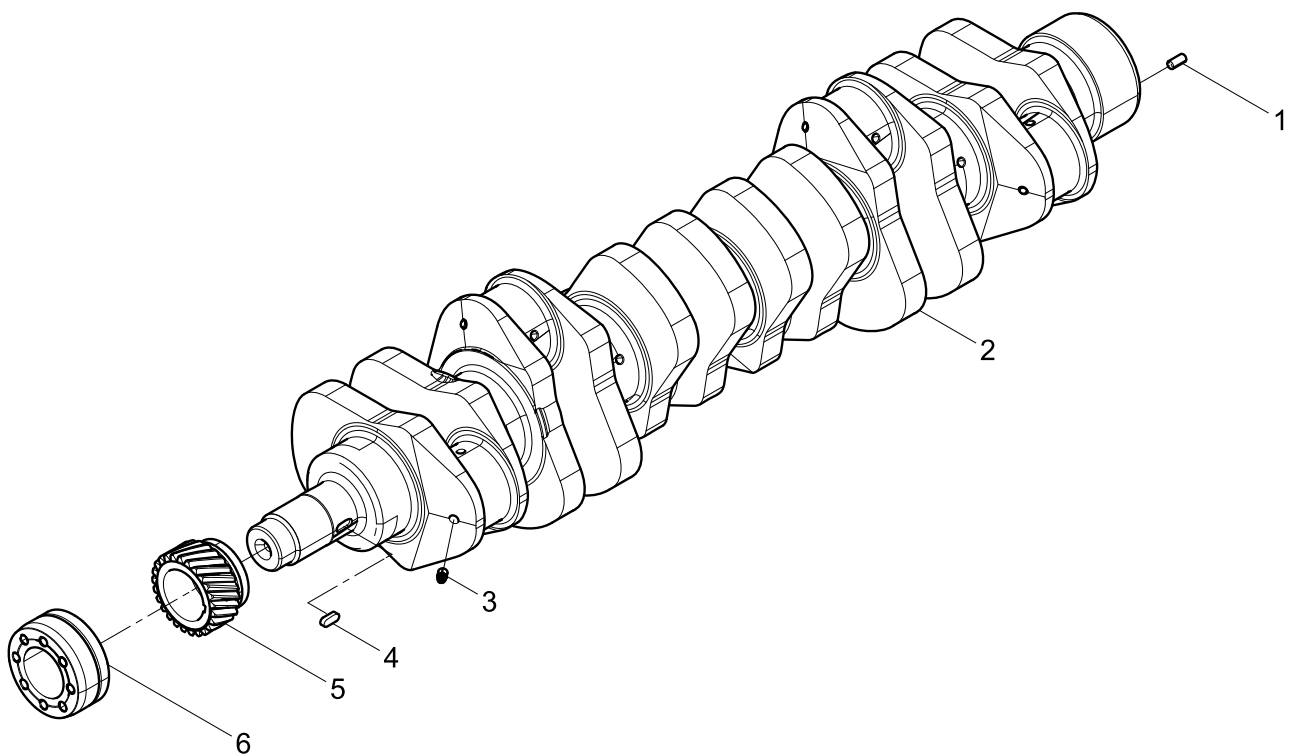

曲轴总成(Crankshaft assembly)

图序号 Pos.	件号 Teile.Number	数量 Amount	中文名称 Denomination	英文名称 Designation
1	90003901418	1	圆柱销	Straight pin
2	612600020865	1	曲轴	Crankshaft
3	612600020311	6	堵塞	Plug
4	612600020040	1	平键	Flat key
5	612600020036	1	曲轴正时齿轮	Timing gear of crankshaft
6	612600020335	1	法兰	Flange

活塞连杆结合组(Piston and Connecting Rod Group)

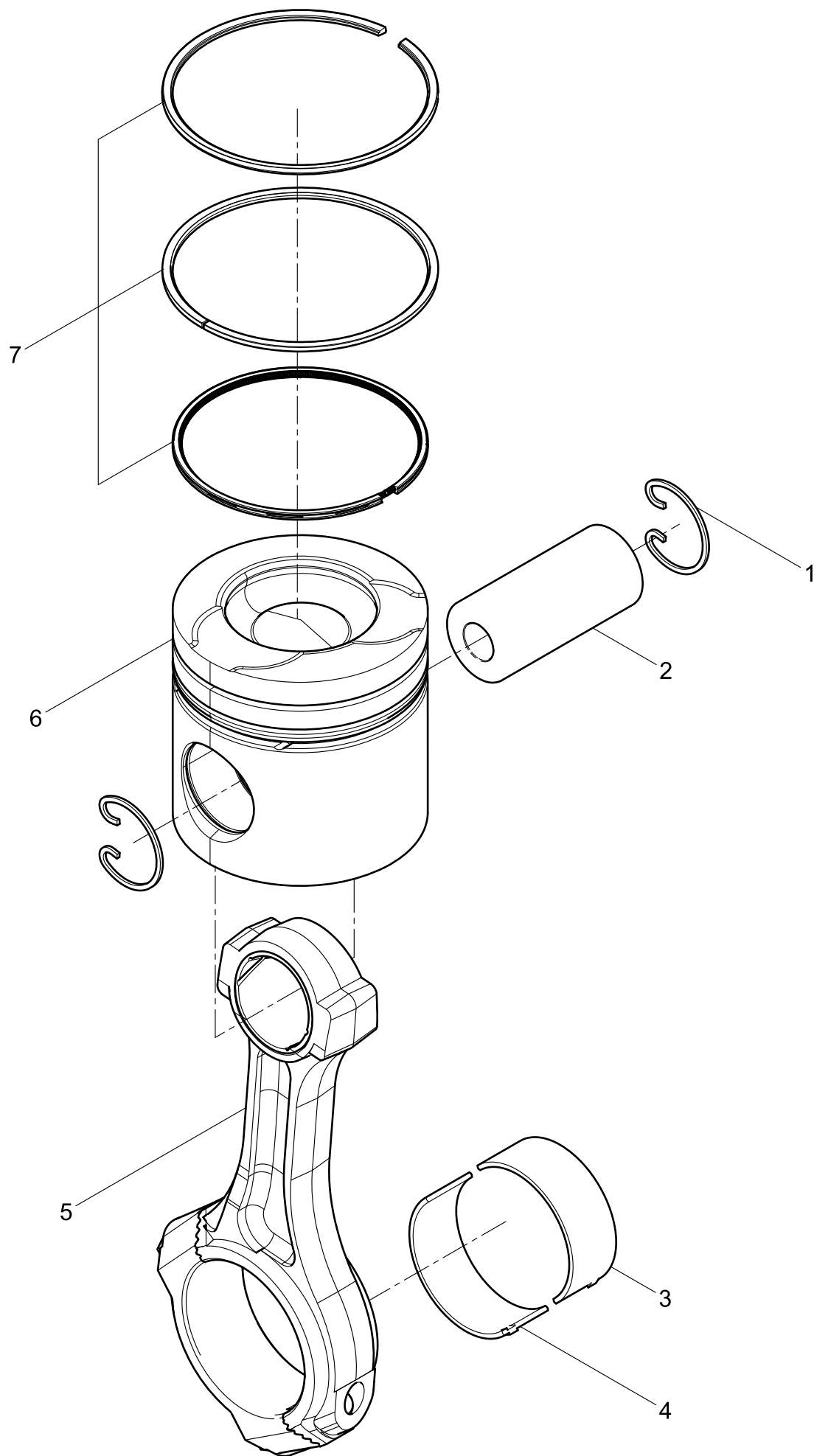

活塞连杆结合组(Piston and Connecting Rod Group)

图序号 Pos.	件号 Teile.Number	数量 Amount	中文名称 Denomination	英文名称 Designation
1	81560030012	12	活塞销挡圈	Piston pin retainer
2	61560030013	6	活塞销	Piston pin
3	612600030020	6	连杆上瓦	Connecting Rod Upper Shell
4	61560030033	6	连杆下瓦	Connecting Rod Lower Shell
5	61500030009	6	连杆总成	Connecting rod assembly
6	612600030068	6	活塞	Piston
7	612600030053	6	活塞环组件	Piston ring assembly

连杆总成(Connecting rod assembly)

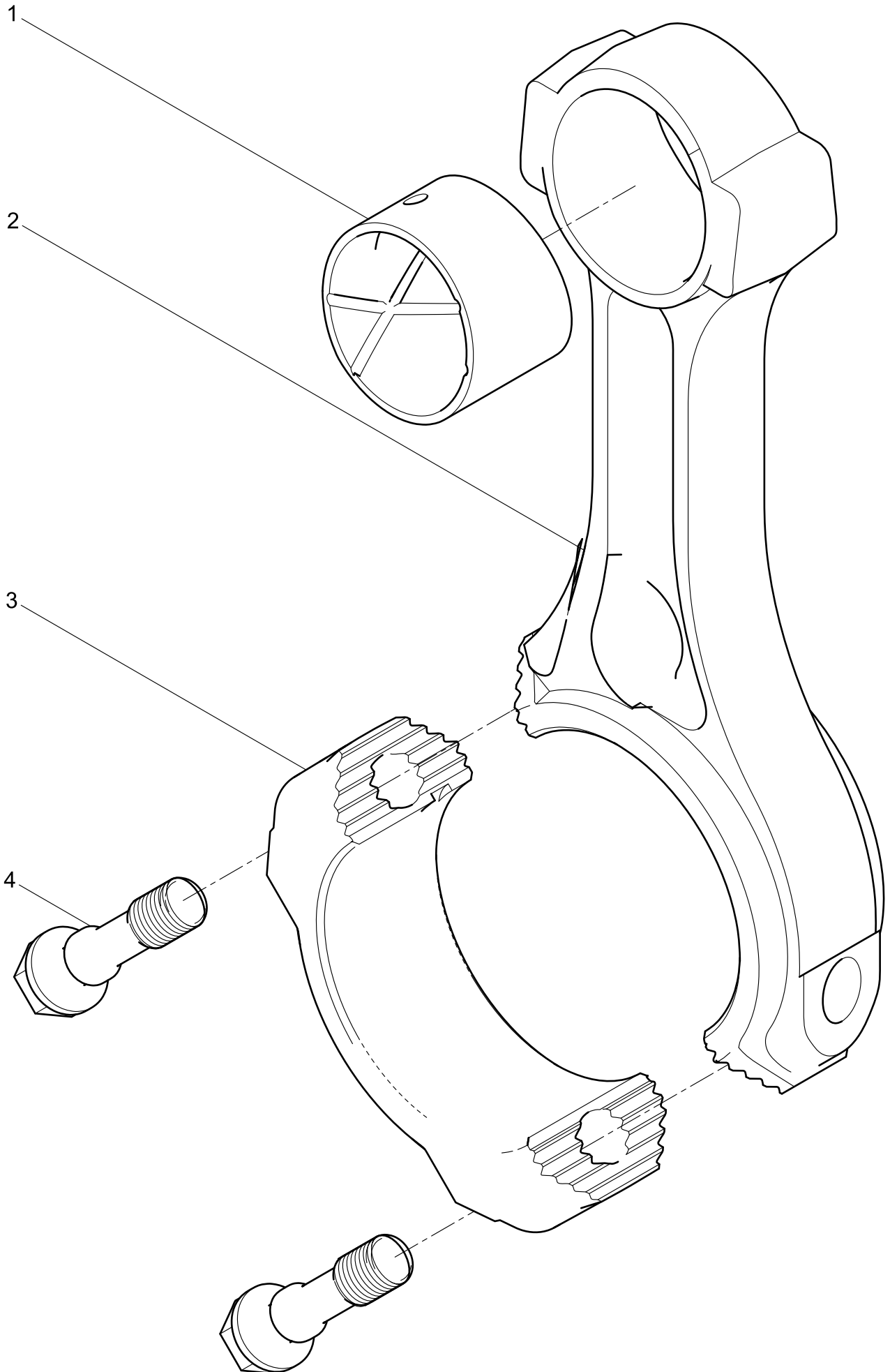

连杆总成(Connecting rod assembly)

图序号 Pos.	件号 Teile.Number	数量 Amount	中文名称 Denomination	英文名称 Designation
1	61500030077	1	连杆衬套	Connecting rod bushing
2	61500030008	1	连杆体	Connecting rod body
3	61500030022	1	连杆盖	Connecting rod cover
4	81500030023	2	连杆螺栓	Connecting rod bolt

活塞环组件(Piston ring assembly)

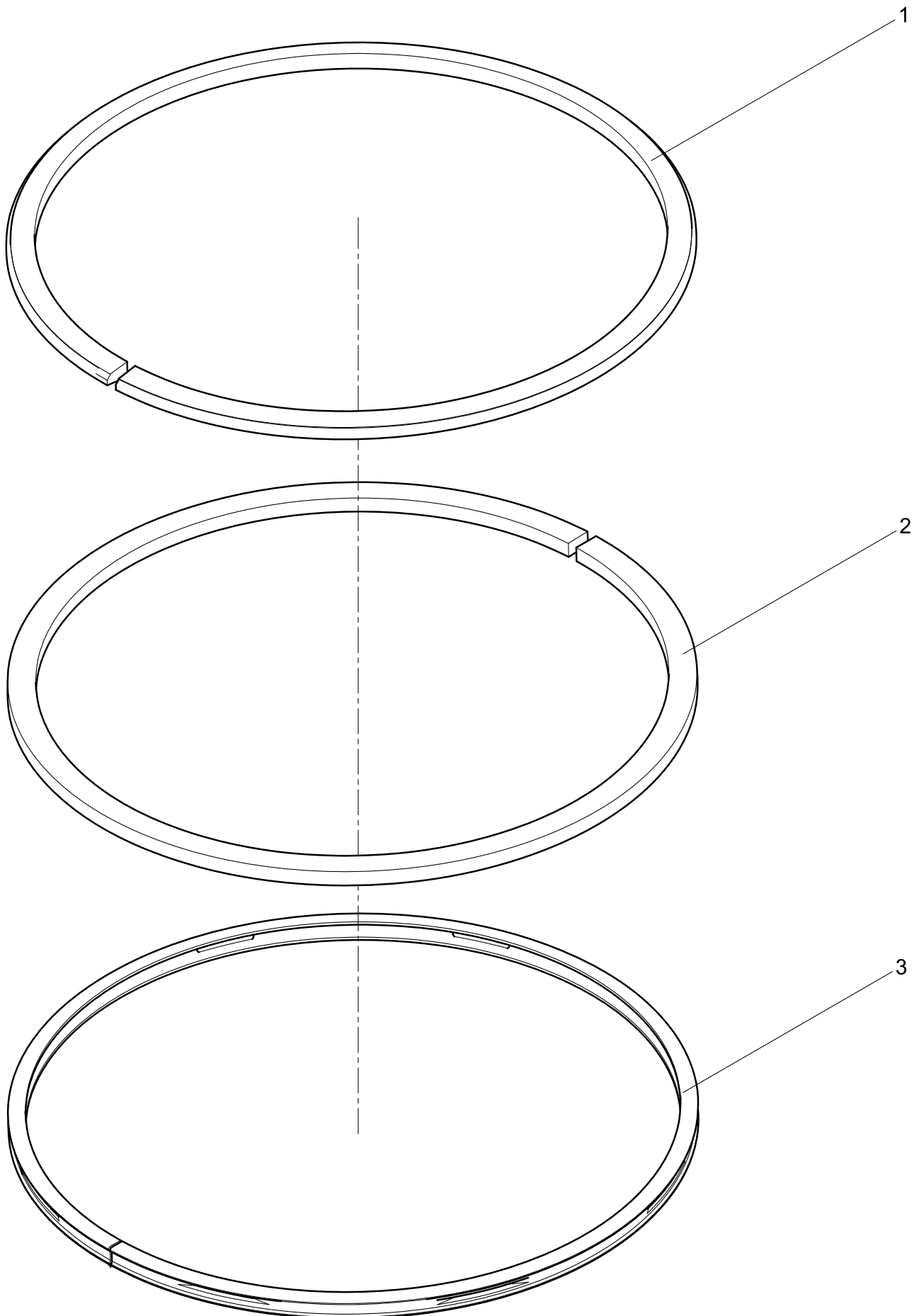

活塞环组件(Piston ring assembly)

图序号 Pos.	件号 Teile.Number	数量 Amount	中文名称 Denomination	英文名称 Designation
1	612600030035	1	梯形桶面环	Taper-sided ring
2	612600030036	1	扭曲锥面环	Conical ring
3	612600030037	1	螺旋撑簧油环	Spiral spring oil ring

气缸盖结合组(Cylinder head assembly)

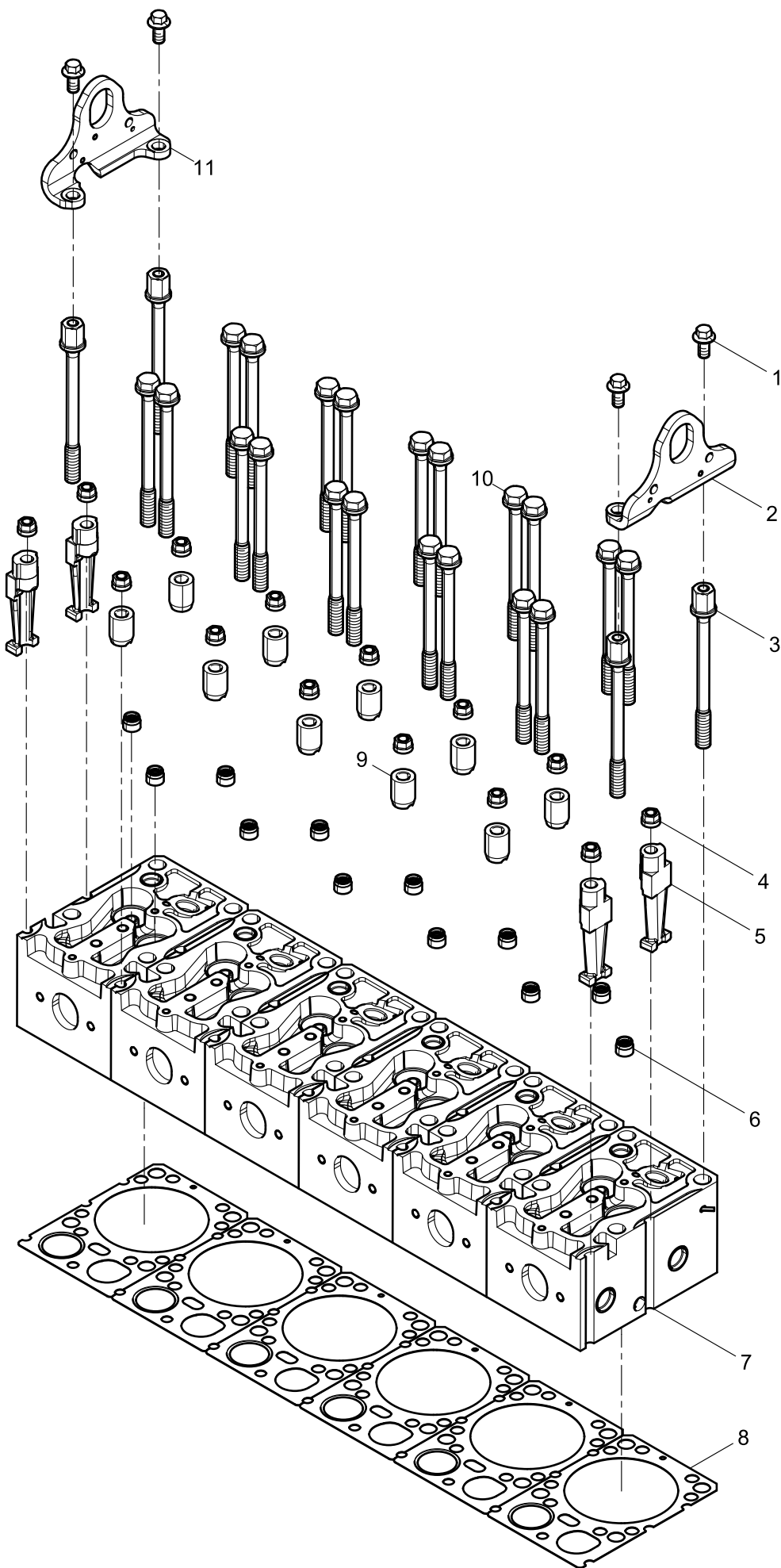

气缸盖结合组(Cylinder head assembly)

图序号 Pos.	件号 Teile.Number	数量 Amount	中文名称 Denomination	英文名称 Designation
1	90011430028	4	六角法兰面承面带齿螺栓	Hexagon Flange Bolt
2	612600040384	1	后吊板	Rear hanger plate
3	612600040453	4	气缸盖主螺栓	Cylinder head main bolt
4	61200040034	14	带肩螺母	Nut
5	61200040027	4	夹紧块	Clamping block
6	612600040114	12	气门阀杆密封套	Seal washer of valve stem
7	612600040362	6	气缸盖分总成	Cylinder head subassembly
8	612600040355	6	气缸盖衬垫	Cylinder head gasket
9	61200040023	10	夹紧块	Clamping block
10	612600040452	20	气缸盖主螺栓	Cylinder head main bolt
11	612600040381	1	前吊板	Front hanger plate

气缸盖分总成(Cylinder head subassembly)

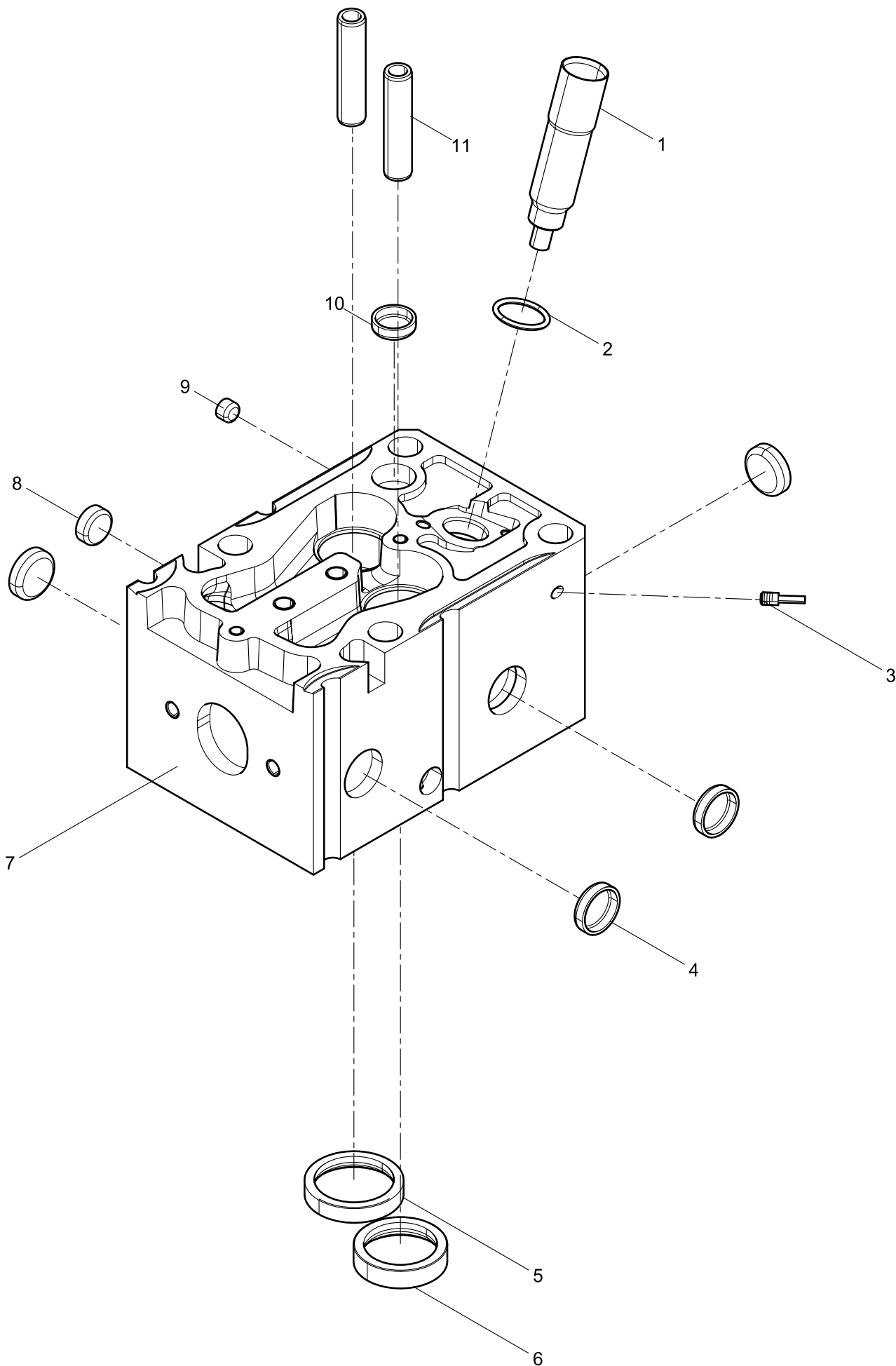

气缸盖分总成(Cylinder head subassembly)

图序号 Pos.	件号 Teile.Number	数量 Amount	中文名称 Denomination	英文名称 Designation
1	612600040235	6	喷油器衬套	Injector bushing
2	612600040240	6	密封圈	Seal washer
3	612600040228	6	拉铆钉	Tensioned rivet
4	90003989294	24	碗形塞	Corehole plug
5	61560040057	6	进气门座	Intake valve seat
6	81560040037	6	排气门座	Exhaust valve seat
7	612600040361	6	气缸盖	Cylinder head
8	90003989721	6	碗形塞片	Corehole plug
9	90003989277	6	碗形塞片	Corehole plug
10	90003989725	6	碗形塞片	Corehole plug
11	612600040113	12	气门导管	Valve guide

配气机构结合组(Valve Train Group)

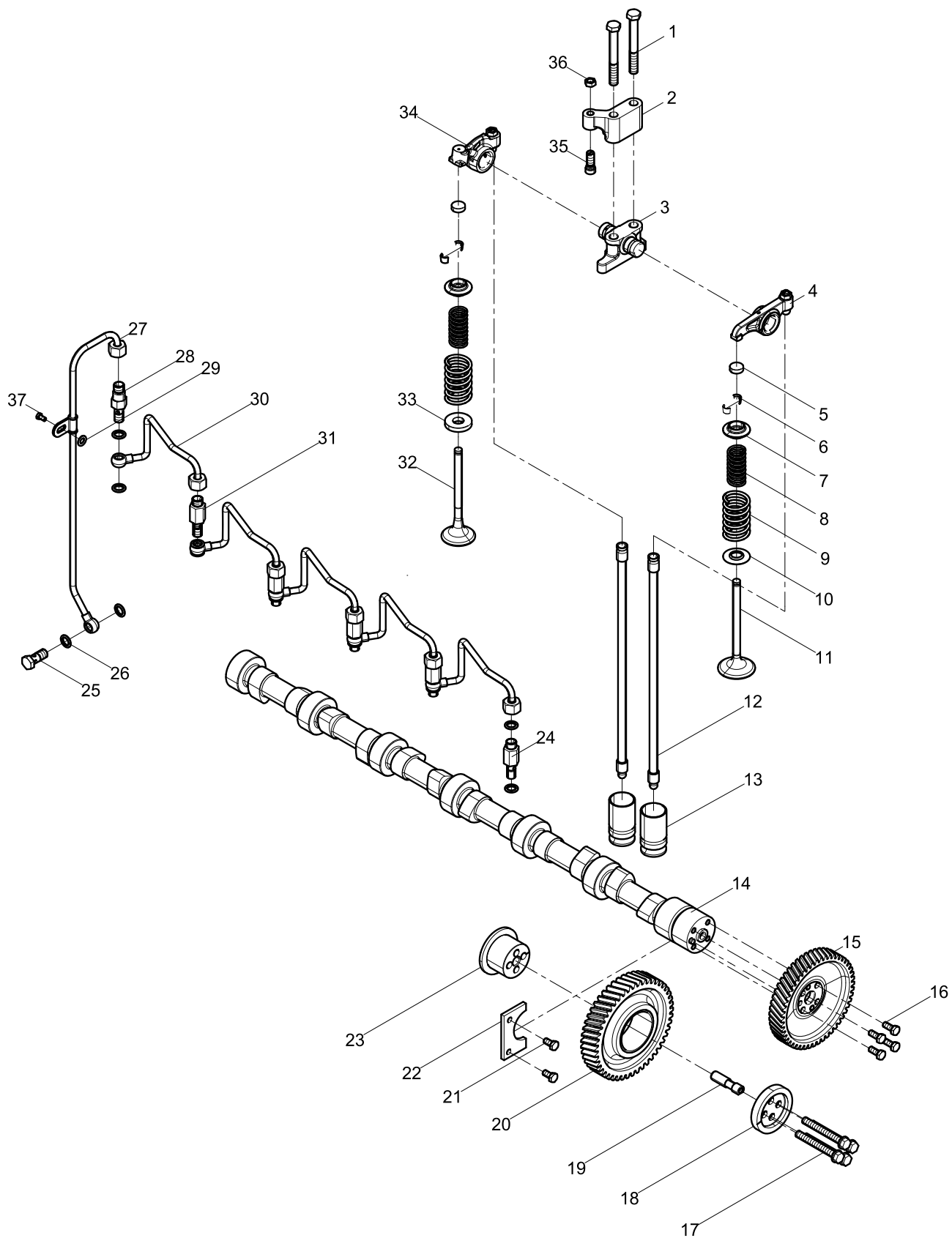

配气机构结合组(Valve Train Group)

图序号 Pos.	件号 Teile.Number	数量 Amount	中文名称 Denomination	英文名称 Designation
1	90011350067	12	六角头螺栓	Hexagon bolt
2	612600050028	6	支撑臂	Carrying arm
3	612600050027	3	气门摇臂座总成	Valve rocker arm seat assembly
4	612600050177	6	进气门摇臂总成	Intake valve rocker arm
5	61500050105	12	气门帽	Valve cap
6	61500050025	24	气门锁夹	Valve collet
7	61500050109	12	气门弹簧上座	Valve spring seat (upper)
8	61500050001	12	气门内弹簧	Inner valve spring
9	61500050002	12	气门外弹簧	Outer valve spring
10	614050017	6	进气门弹簧下座	Intake valve spring seat (lower)
11	612600050073	6	进气门	Intake valve
12	612600050210	12	推杆	Push rod
13	61500050032	12	气门挺柱	Tappet
14	612600050087	1	凸轮轴总成	Camshaft assembly
15	614050053	1	凸轮轴正时齿轮	Camshaft timing gear
16	612600050145S	4	六角头螺栓	Hexagon bolt
17	61560050059S	4	六角头螺栓	Hexagon bolt
18	61560050045	1	垫片	Gasket
19	61560050058	1	轴	Shaft
20	61560050053	1	中间齿轮总成	Intermediate gear assembly
21	90003802399S	2	六角头螺栓	Hexagon bolt
22	614050133	1	凸轮轴止推片	Camshaft thrust
23	61560050044	1	中间齿轮轴	Intermediate gear shaft
24	612600050041	1	螺纹接头	Screw joint
25	612600050039	1	空心螺栓	Hollow bolt
26	612600050042	13	密封垫圈	Seal washer
27	612600050123	1	EVb进油长管	EVb fuel inlet pipe assembly (long)

配气机构结合组(Valve Train Group)

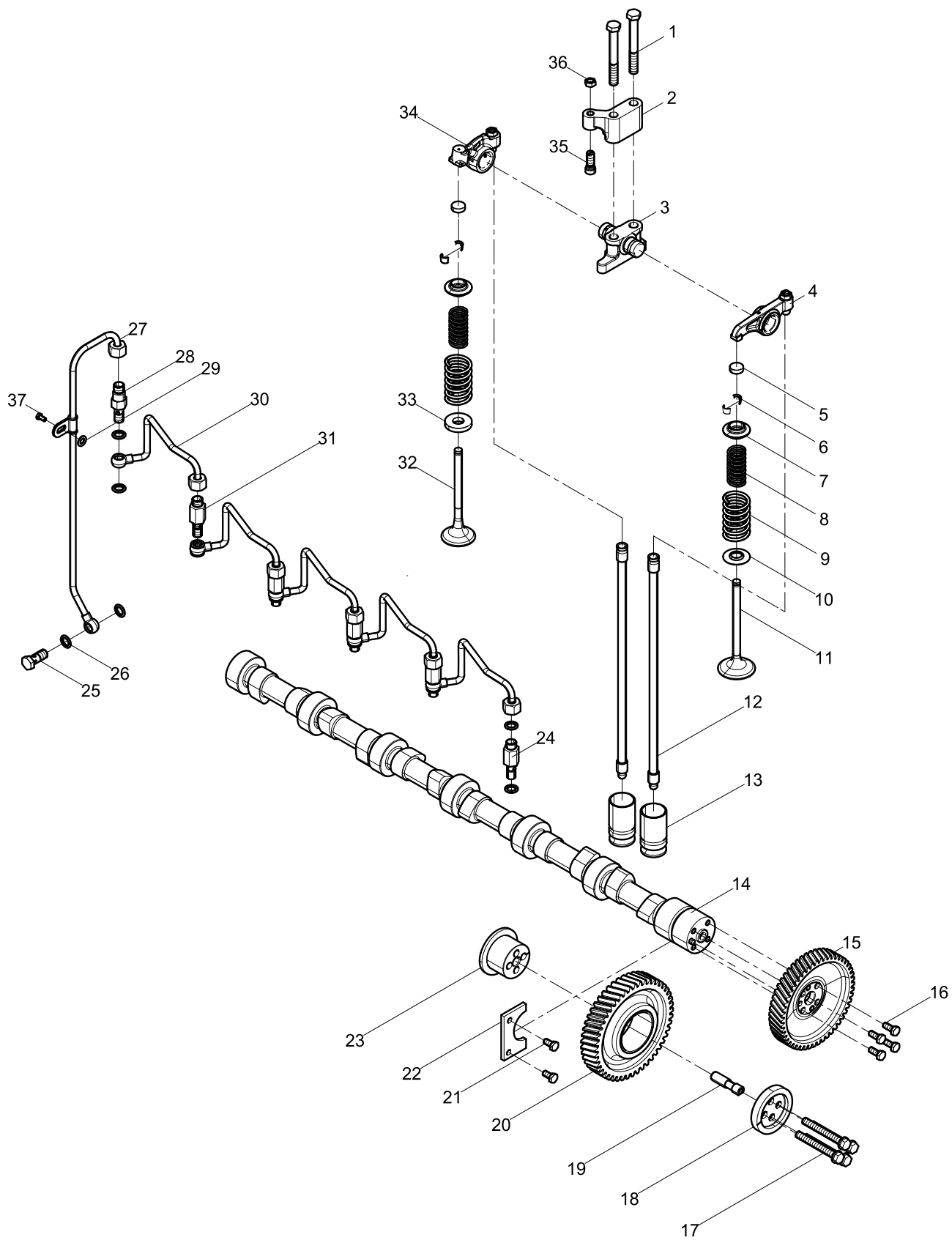

配气机构结合组(Valve Train Group)

图序号 Pos.	件号 Teile.Number	数量 Amount	中文名称 Denomination	英文名称 Designation
28	612600050107	1	空心螺栓接头	Hollow bolt adapter
29	90003932023	1	波形弹性垫圈	Wave spiral washer
30	612600050088	5	进油短管总成	Fuel inlet pipe assembly (short)
31	612600050040	4	空心螺栓接头	Hollow bolt adapter
32	612600050025	6	排气门	Exhaust valve
33	61500040014	6	排气门弹簧下座	Exhaust valve spring seat (lower)
34	612600050179	6	EVB排气摇臂组件	EVB Exhaust Rocker Arm Set
35	612600050038	6	调节螺栓总成	Adjustment bolt assembly
36	2130050065	6	气门间隙调整螺母	Valve adjusting nut
37	90003802411	1	六角头螺栓	Hexagon bolt

凸轮轴总成(Camshaft assembly)

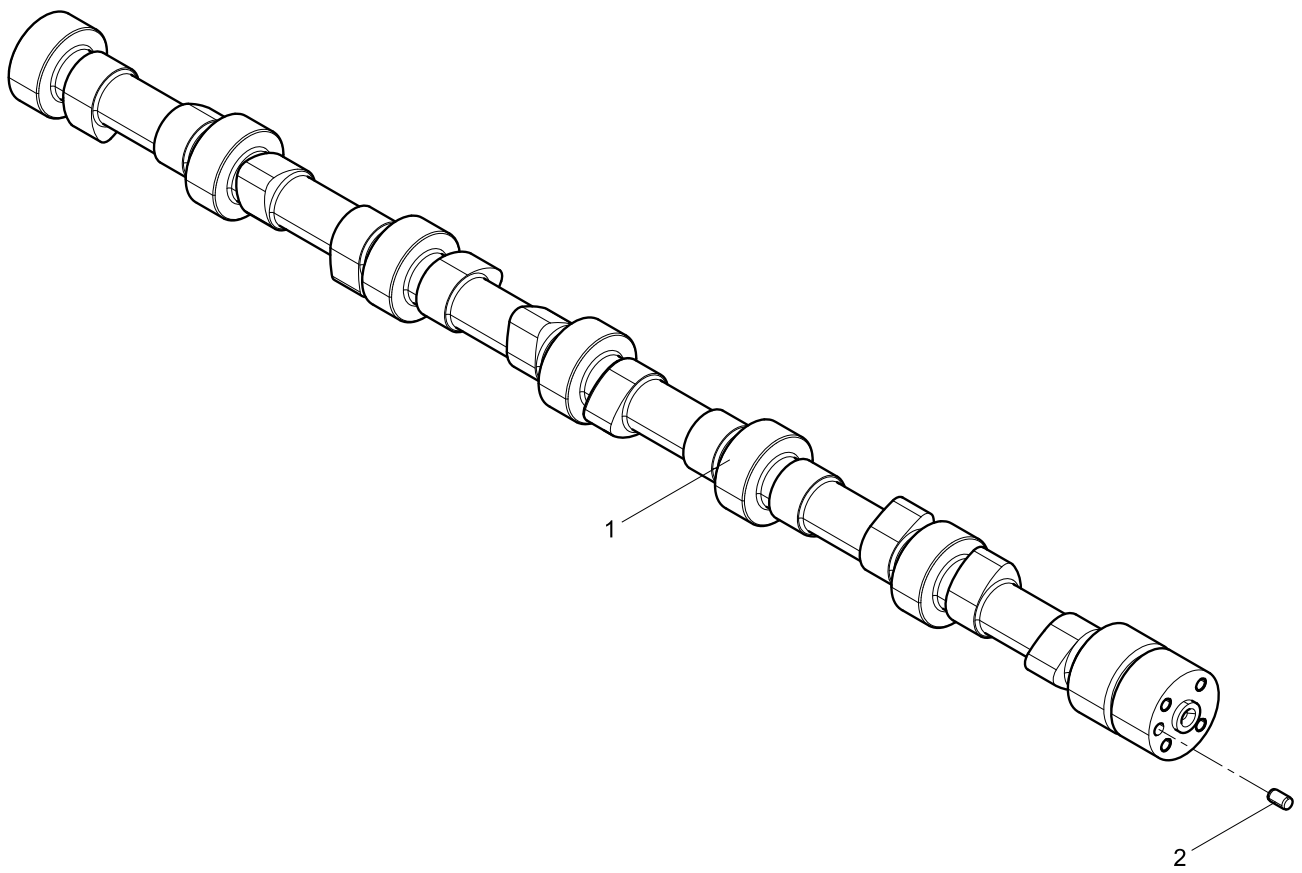

EVB排气摇臂组件(EVB Exhaust Rocker Arm Set)

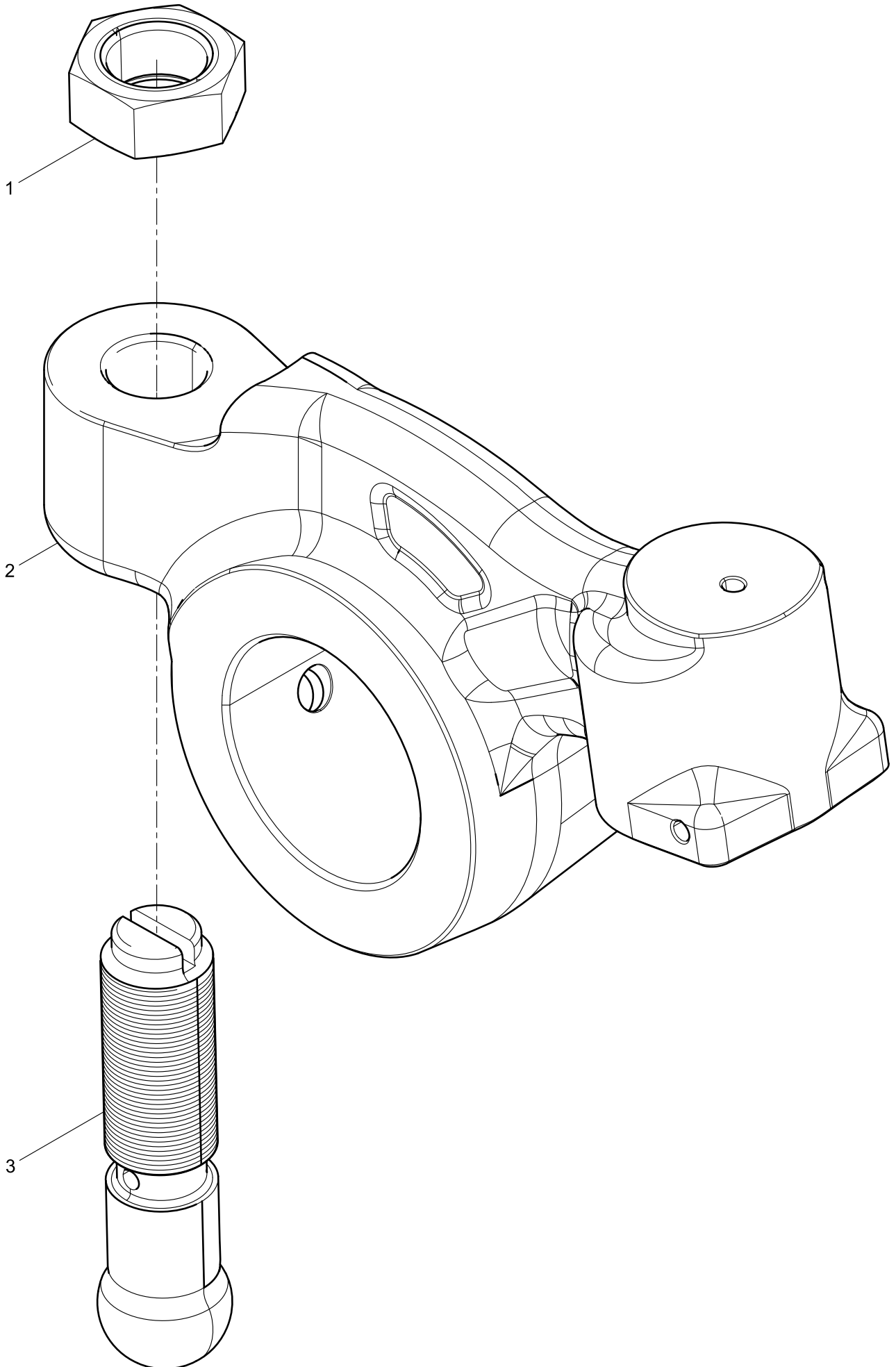

EVB排气摇臂组件(EVB Exhaust Rocker Arm Set)

图序号 Pos.	件号 Teile.Number	数量 Amount	中文名称 Denomination	英文名称 Designation
1	2130050065	6	气门间隙调整螺母	Valve adjusting nut
2	612600050059	6	排气门摇臂组件	Exhaust valve rocker arm
3	612600050043	6	气门间隙调节螺钉	Valve Adjusting Bolt

进气门摇臂总成(Intake valve rocker arm)

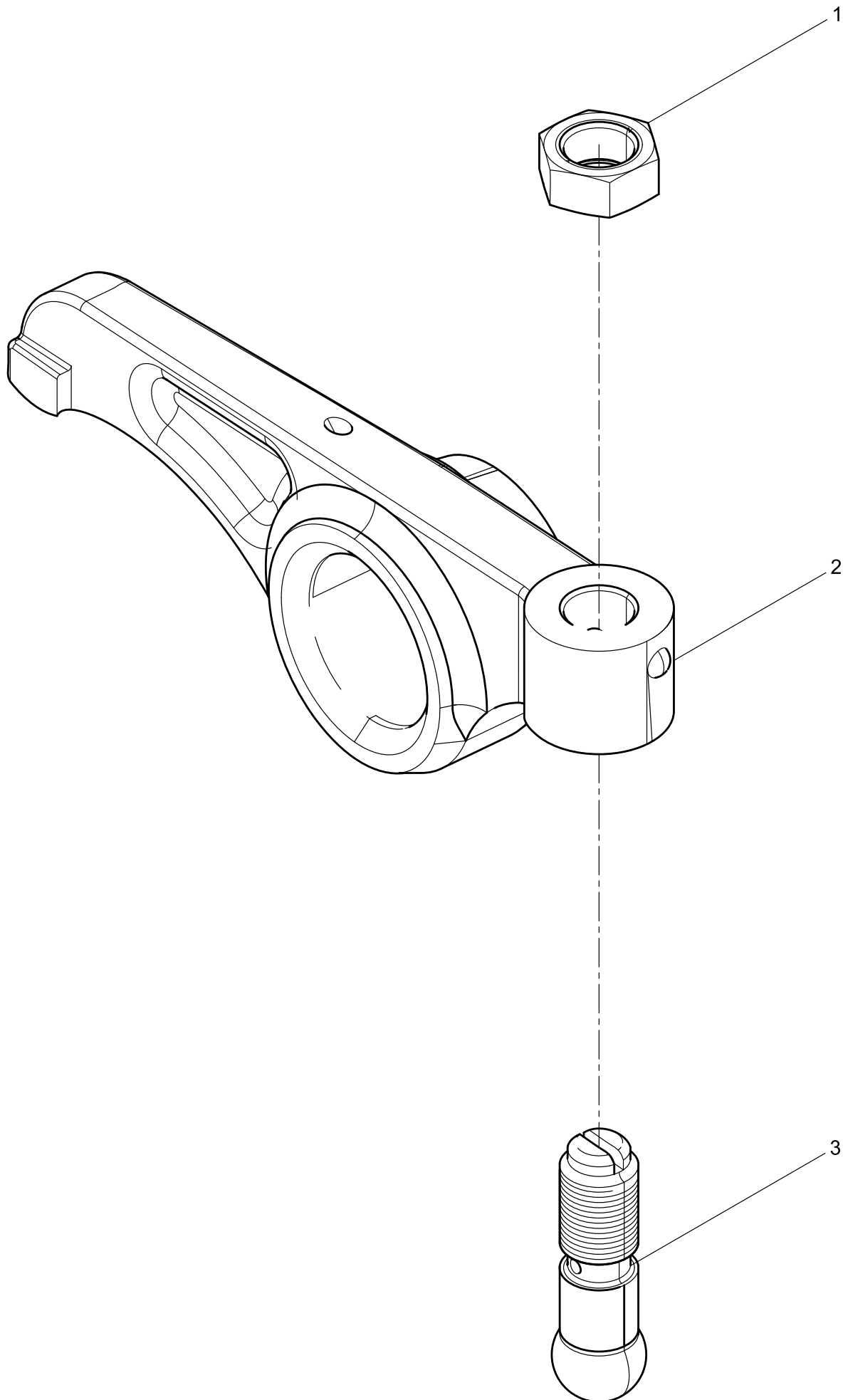

进气门摇臂总成(Intake valve rocker arm)

图序号 Pos.	件号 Teile.Number	数量 Amount	中文名称 Denomination	英文名称 Designation
1	2130050065	6	气门间隙调整螺母	Valve adjusting nut
2	614050048	6	进气摇臂	Intake Rocker Arm
3	614050010	6	气门间隙调整螺钉	Valve Adjusting Bolt

中间齿轮总成(Intermediate gear assembly)

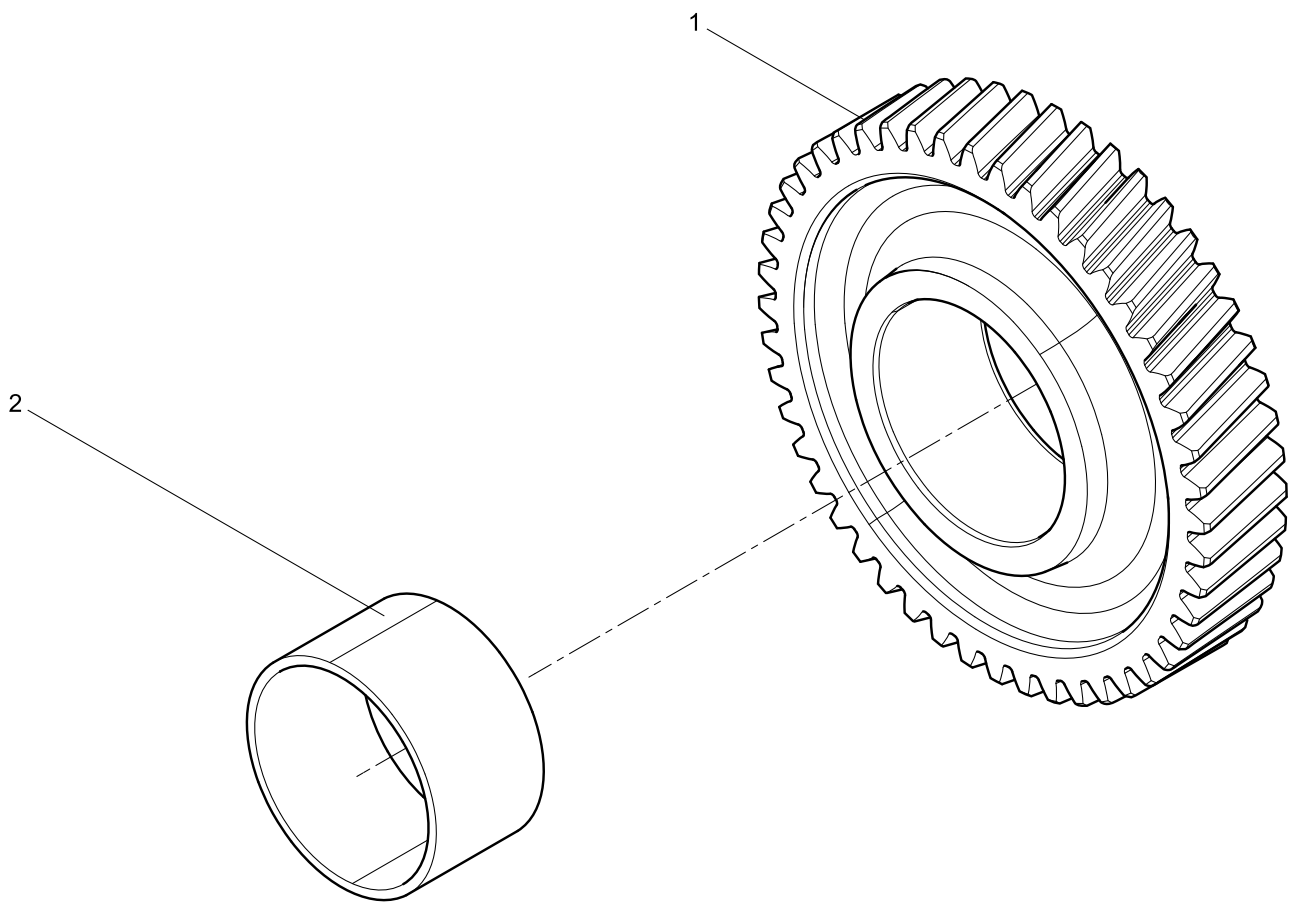

中间齿轮总成(Intermediate gear assembly)

图序号 Pos.	件号 Teile.Number	数量 Amount	中文名称 Denomination	英文名称 Designation
1	61560050052	1	中间齿轮	Intermediate gear
2	61560050051	1	衬套	Bushing

机油泵结合组(Oil pump assembly)

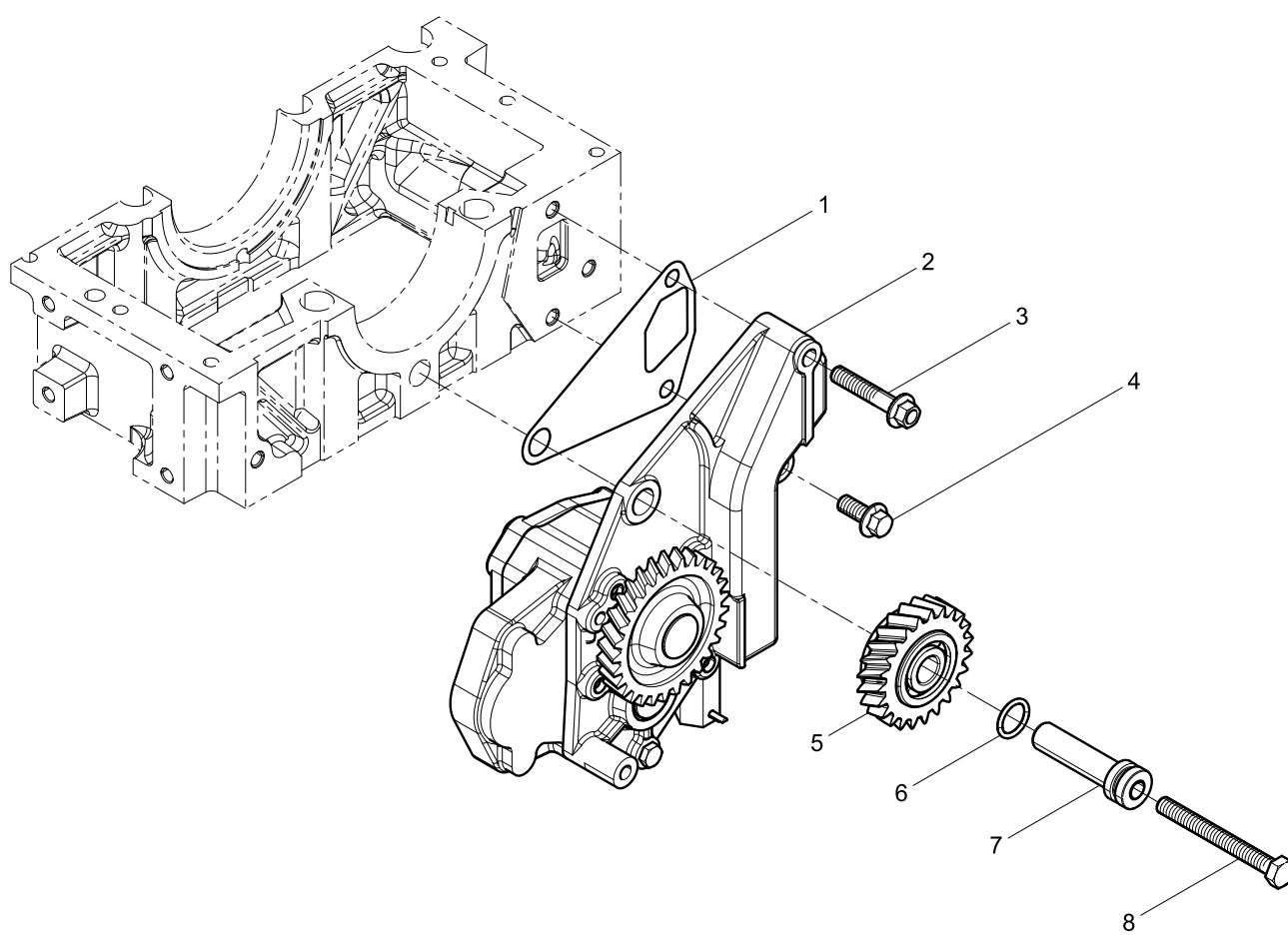

机油泵结合组(Oil pump assembly)

图序号 Pos.	件号 Teile.Number	数量 Amount	中文名称 Denomination	英文名称 Designation
1	614070055	1	机油泵垫片	Oil pump gasket
2	612600070484	1	机油泵	Oil pump
3	612600070411	1	六角法兰面承面带齿螺栓	Hexagon Flange Bolt
4	90011430008	1	六角法兰面承面带齿螺栓	Hexagon Flange Bolt
5	612600070364	1	机油泵中间齿轮组件	Oil Pump Idle Gear Assembly
6	614070155	1	密封圈	Seal washer
7	6140756	1	中间齿轮轴	Intermediate gear shaft
8	90003802578S	1	六角头螺栓	Hexagon bolt

机油泵中间齿轮组件(Oil Pump Idle Gear Assembly)

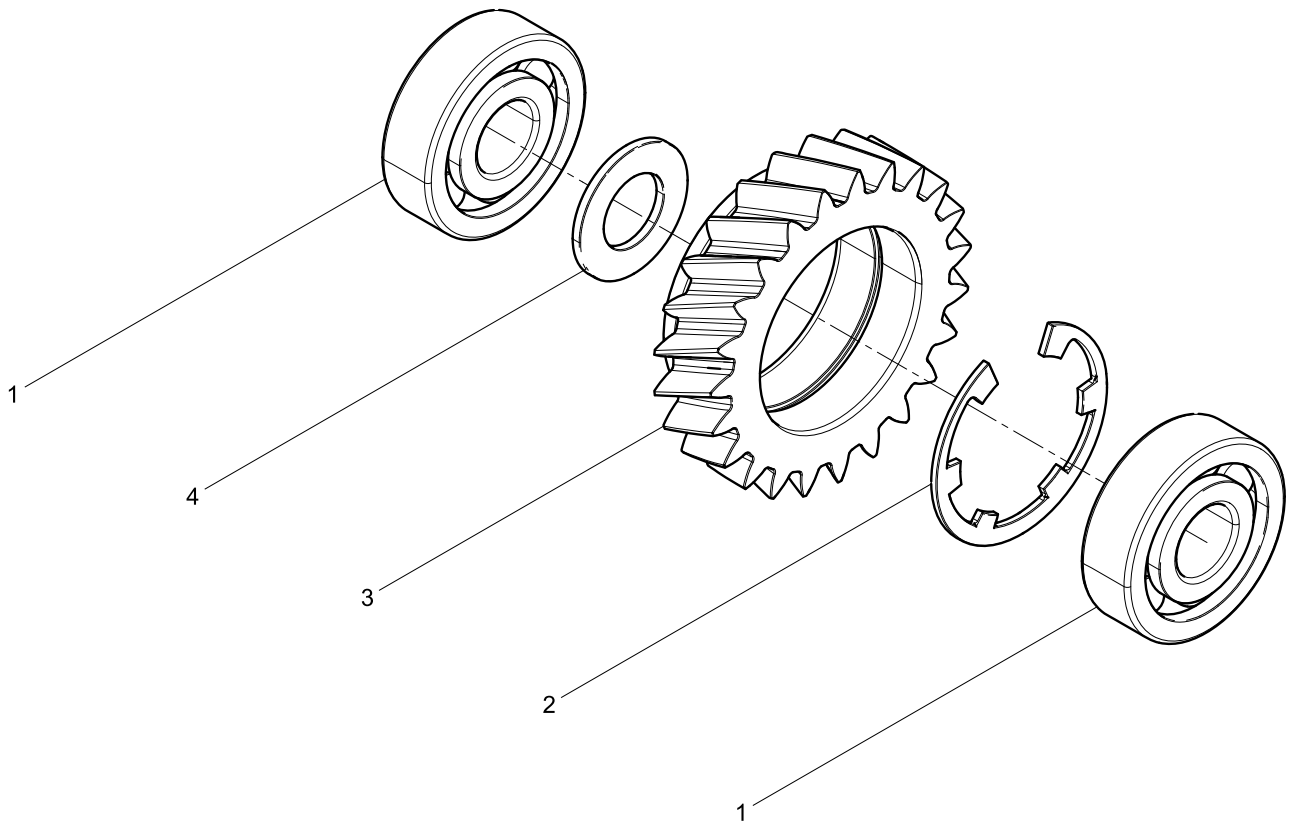

机油冷却器结合组(Oil cooler assembly)

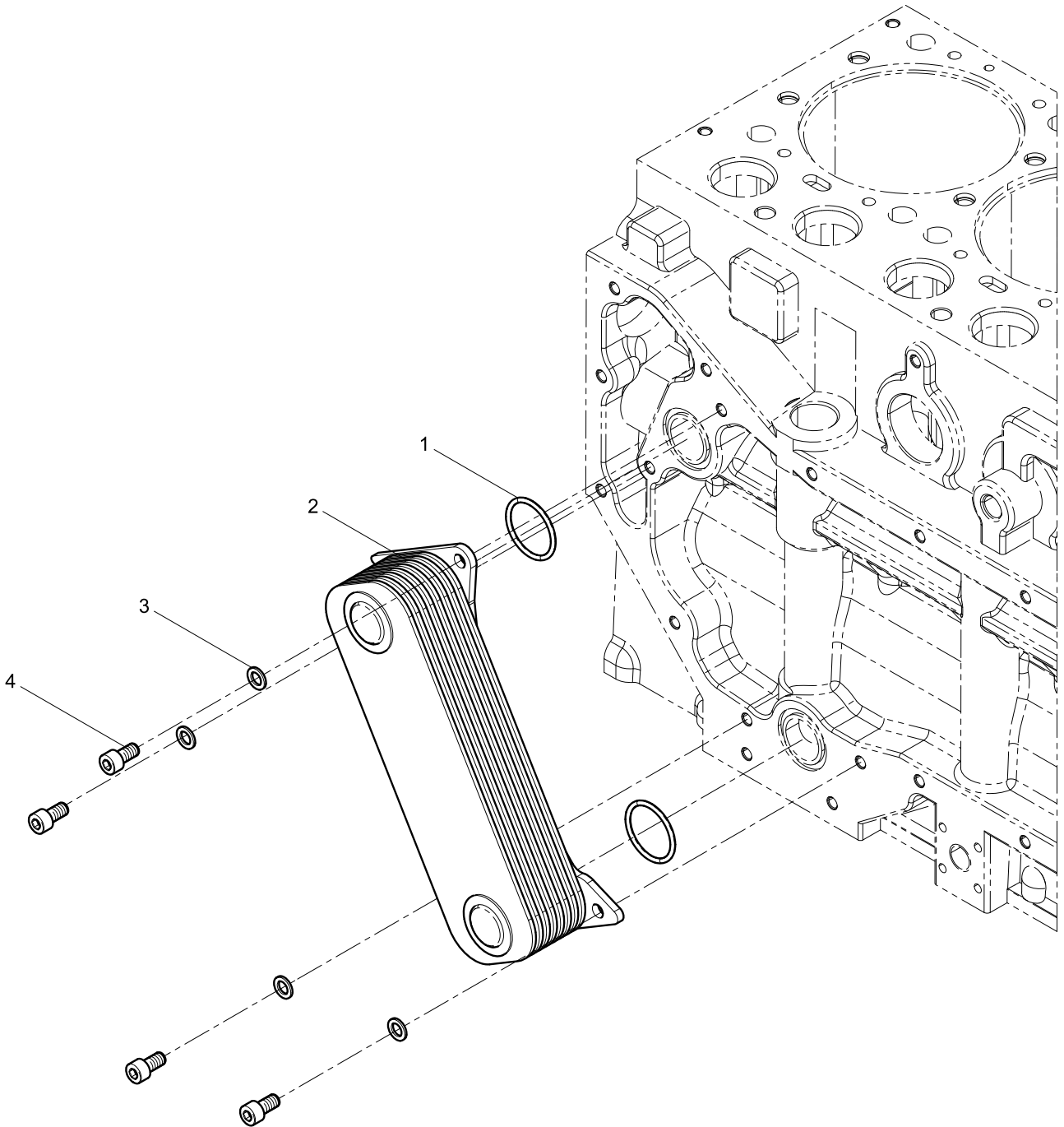

机油冷却器结合组(Oil cooler assembly)

图序号 Pos.	件号 Teile.Number	数量 Amount	中文名称 Denomination	英文名称 Designation
1	81400010032	2	密封圈	Seal washer
2	61500010334	1	机油冷却器	Oil cooler
3	90003932023	4	波形弹性垫圈	Wave spiral washer
4	90003862419S	4	内六角圆柱头螺钉	Inner hexagon screw

共轨系统结合组()

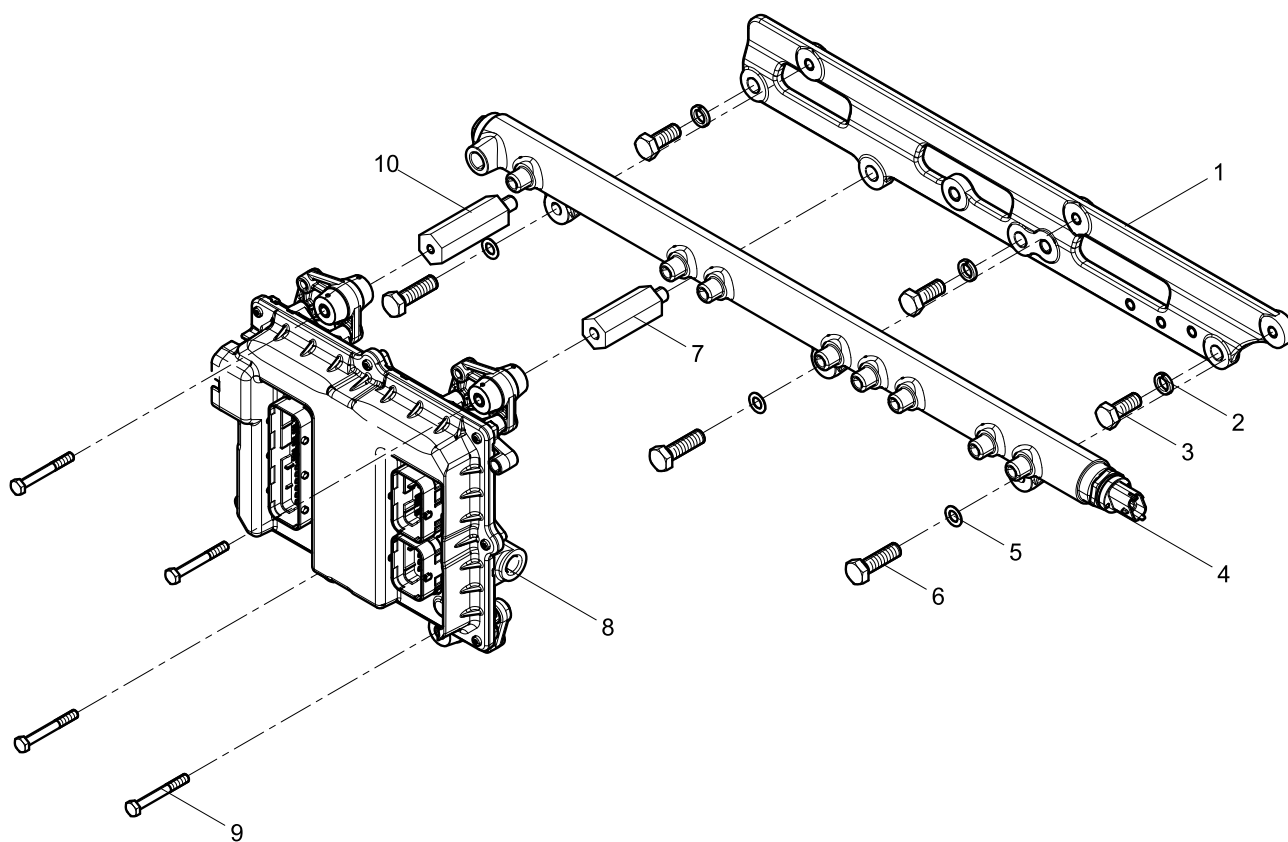

共轨系统结合组()

图序号 Pos.	件号 Teile.Number	数量 Amount	中文名称 Denomination	英文名称 Designation
1	612600080661	1	支架	Bracket
2	90003931122	3	弹簧垫圈	Spring washer
3	90003802523	3	六角头螺栓	Hexagon bolt
4	612630080038	1	共轨管	Common rail pipe
5	90003932023	3	波形弹性垫圈	Wave spiral washer
6	90003802437	3	六角头螺栓	Hexagon bolt
7	612600080660	1	螺钉	Screw
8	612630080110	1	电控单元组件	
9	612639000050	4	六角头螺栓	Hexagon bolt
10	612600080659	1	螺钉	Screw

电控单元组件0

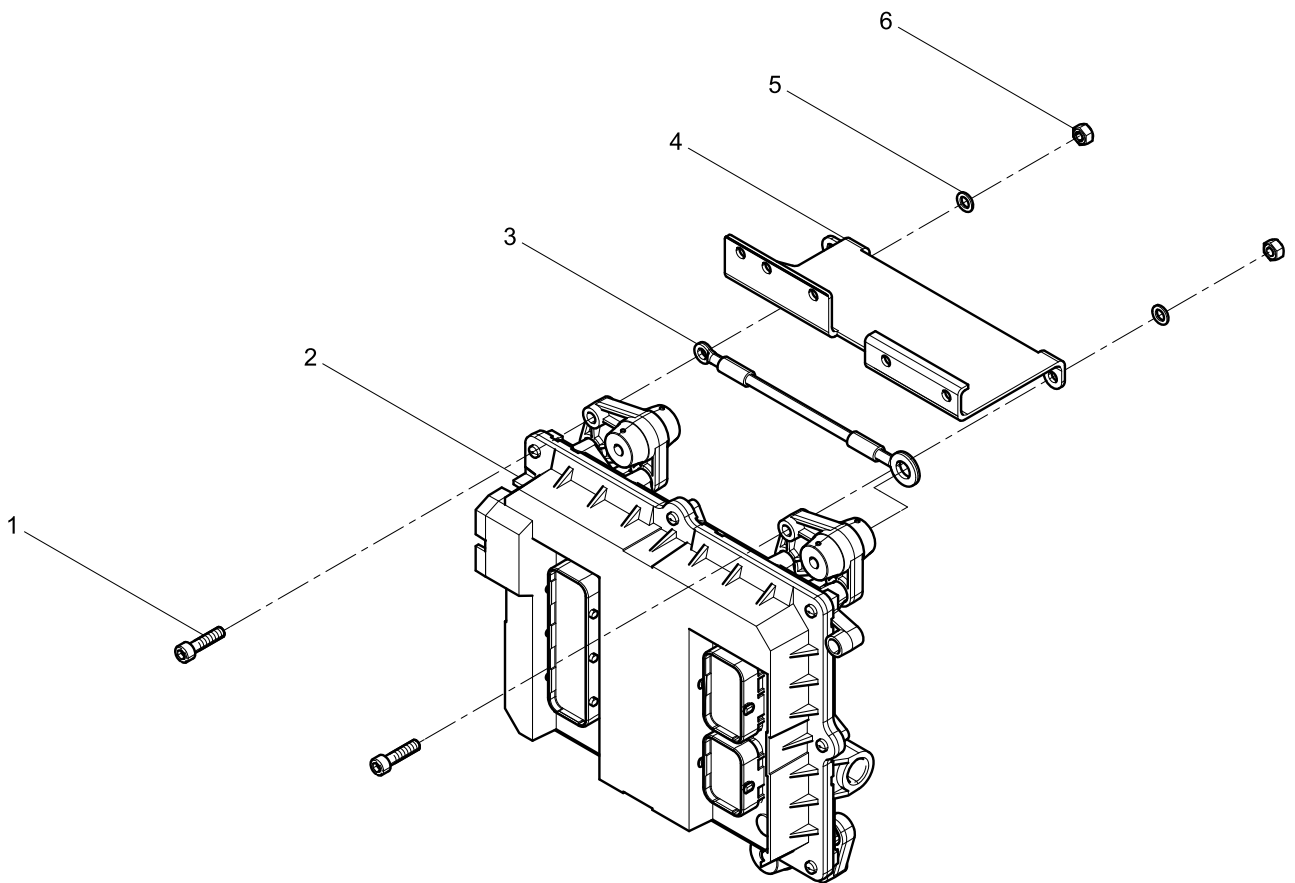

高压油泵结合组(High pressure pump assembly)

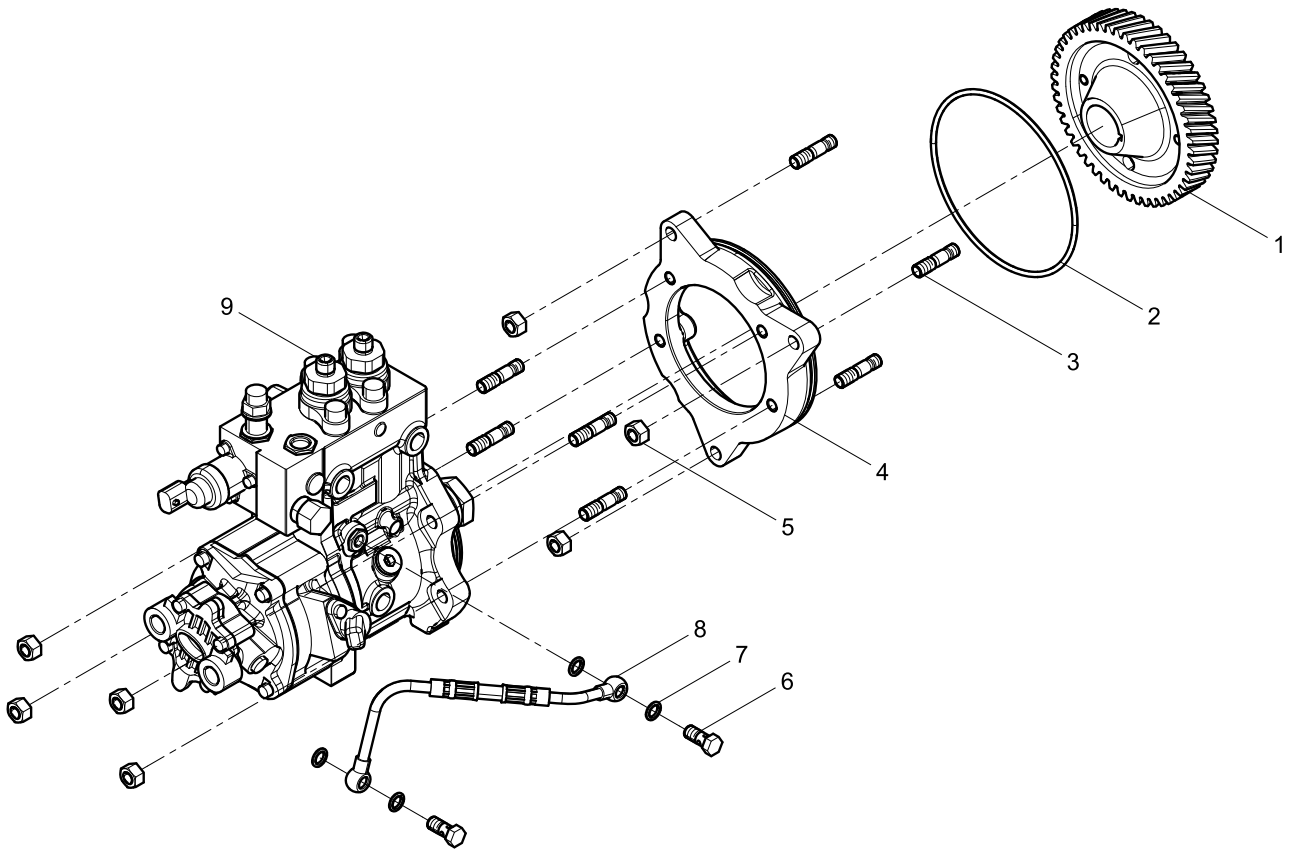

高压油泵结合组(High pressure pump assembly)

图序号 Pos.	件号 Teile.Number	数量 Amount	中文名称 Denomination	英文名称 Designation
1	612600080452	1	喷油泵齿轮	Injection pump gear
2	612600080400	1	密封圈	Seal washer
3	90003813532S	7	双头螺柱	Stud
4	612600080486	1	喷油泵法兰	Injection pump flange
5	90003888452	7	2型全金属六角锁紧螺母	Prevailing Torque Type All-metal Hexagon Nut,
6	612639000047	2	空心螺栓	Hollow bolt
7	612600080246	4	密封垫圈	Seal washer
8	612600070309	1	润滑油进油管组件	Oil inlet pipe assembly
9	612600080674	1	共轨喷油泵	Injection pump

高压油管组件(High pressure pipe assembly)

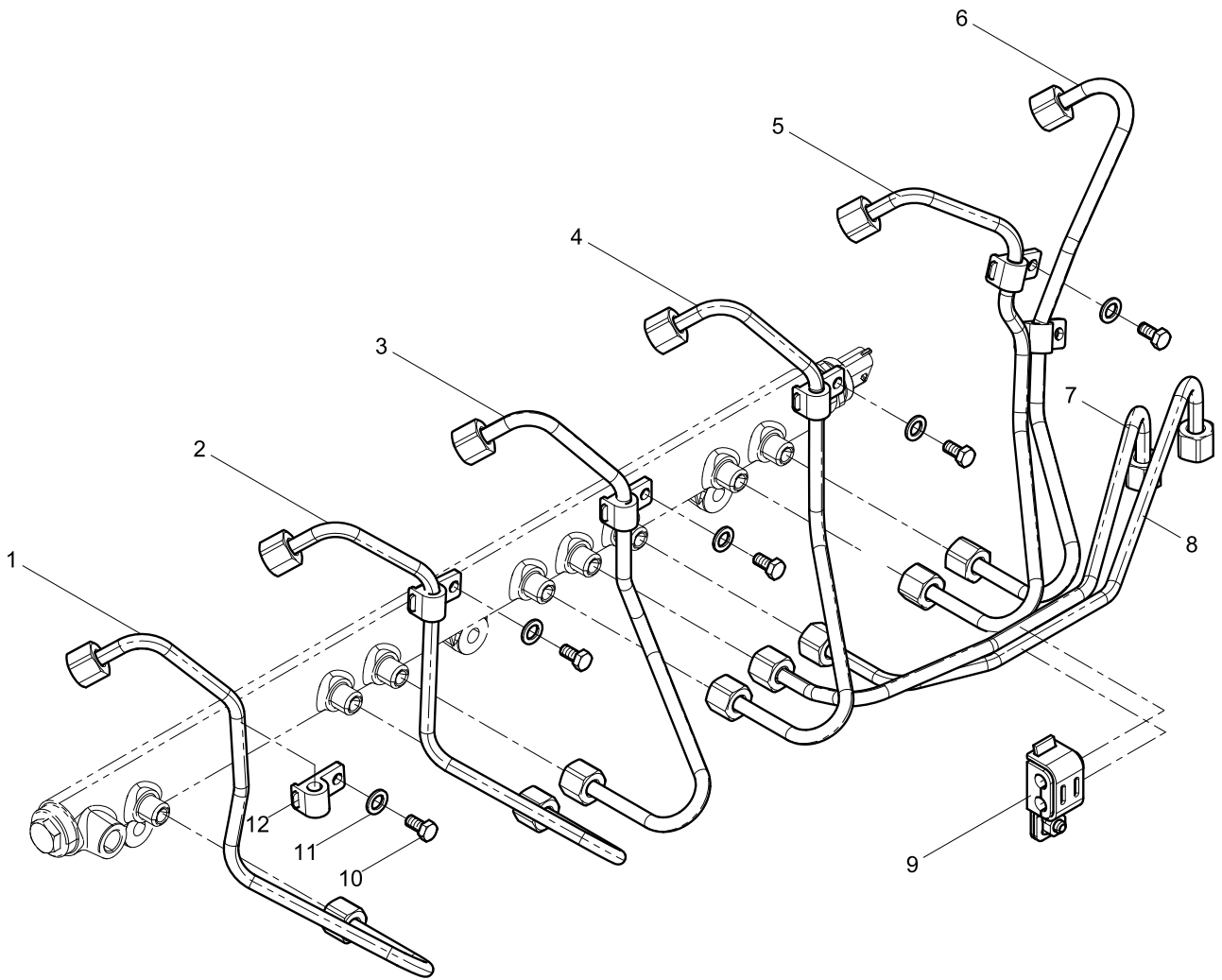

高压油管组件(High pressure pipe assembly)

图序号 Pos.	件号 Teile.Number	数量 Amount	中文名称 Denomination	英文名称 Designation
1	612600080638	1	第六缸高压油管	High pressure pipe(cylinder 6)
2	612600080637	1	第五缸高压油管	High pressure pipe(cylinder 5)
3	612600080636	1	第四缸高压油管	High pressure pipe(cylinder 4)
4	612600080635	1	第三缸高压油管	High pressure pipe(cylinder 3)
5	612600080634	1	第二缸高压油管	High pressure pipe(cylinder 2)
6	612600080633	1	第一缸高压油管	High pressure pipe(cylinder 1)
7	612600080639	1	高压油管(泵到轨)	High pressure pipe (from pump to rail)
8	612600080640	1	高压油管(泵到轨)	High pressure pipe (from pump to rail)
9	612630080058	1	管卡	Pipe Clip
10	90003802411	5	六角头螺栓	Hexagon bolt
11	90003932023	5	波形弹性垫圈	Wave spiral washer
12	612600080672	6	高压油管管卡	Clip of high pressure pipe

端盖结合组()

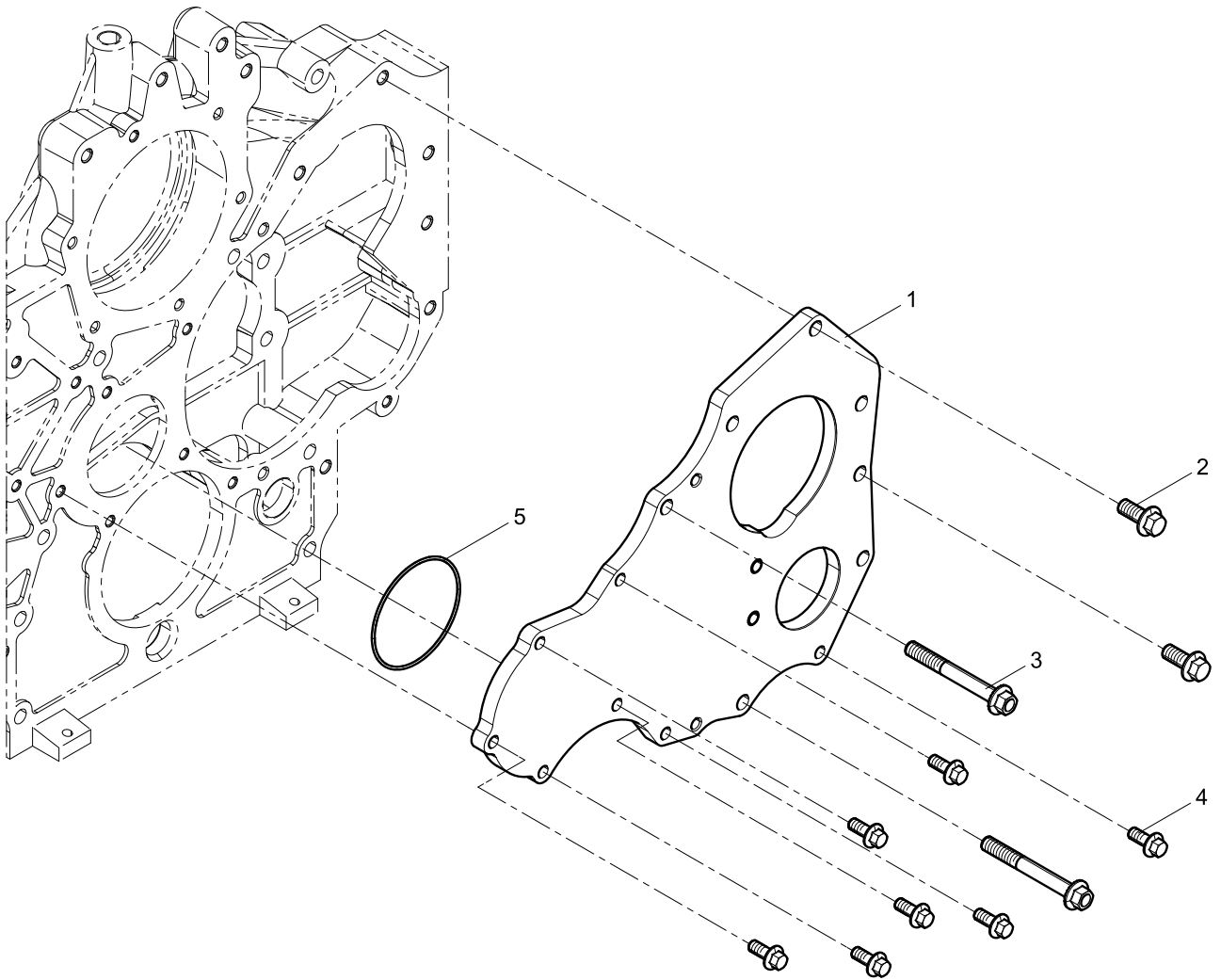

端盖结合组()

图序号 Pos.	件号 Teile.Number	数量 Amount	中文名称 Denomination	英文名称 Designation
1	612600011821	1	端盖	End cover
2	90011430008	2	六角法兰面承面带齿螺栓	Hexagon Flange Bolt
3	612600061711	2	六角法兰面承面带齿螺栓	Hexagon Flange Bolt
4	90011430016S	7	六角法兰面承面带齿螺栓	Hexagon Flange Bolt
5	90003120602	1	密封圈	Seal washer

油气分离器结合组(Oil-gas Separator Group)

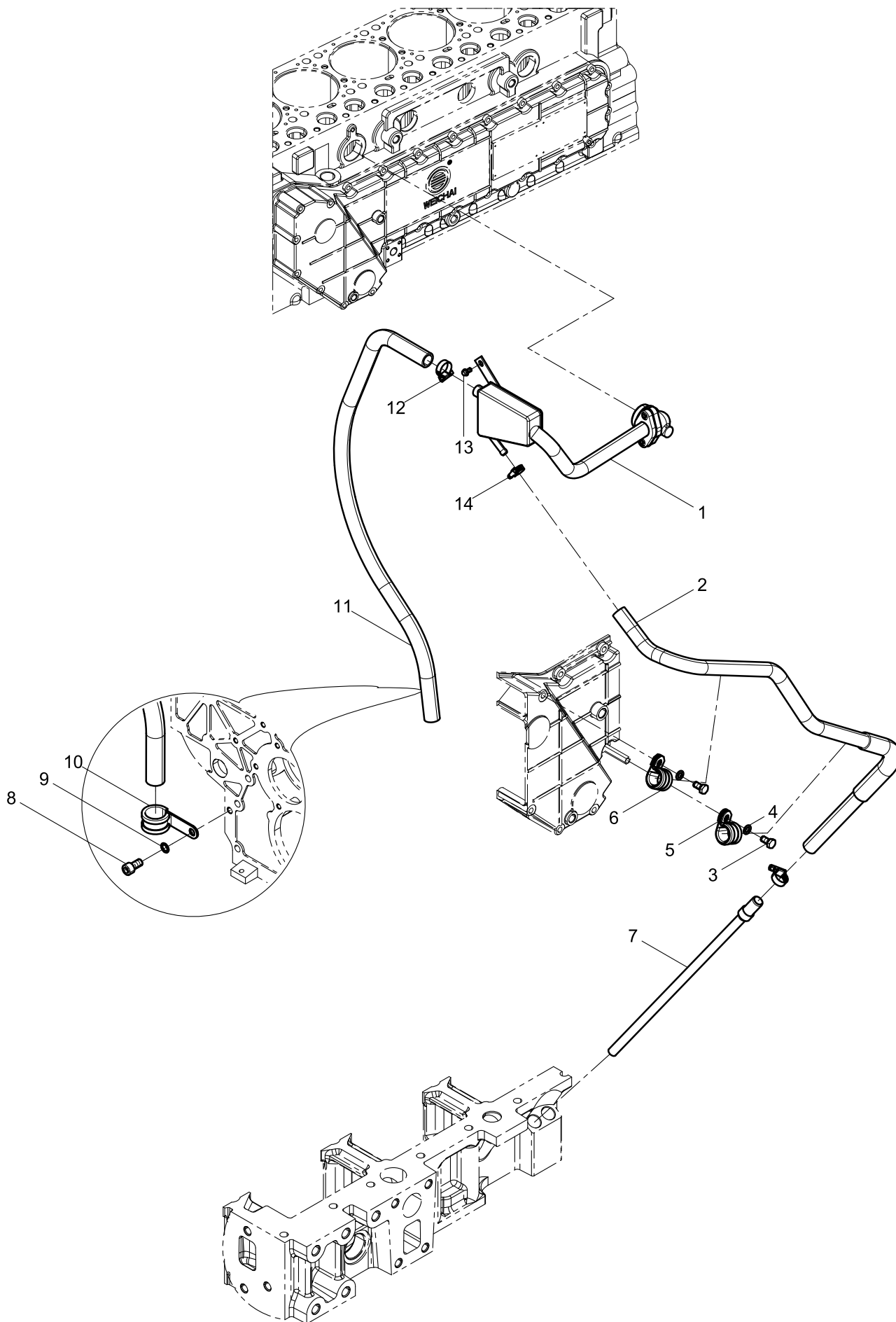

油气分离器结合组(Oil-gas Separator Group)

图序号 Pos.	件号 Teile.Number	数量 Amount	中文名称 Denomination	英文名称 Designation
1	612600013161	1	油气分离器总成	Oil-gas separator assembly
2	612600012729	1	油路连接胶管	Oil Connecting Rubber Pipe
3	90003802411	2	六角头螺栓	Hexagon bolt
4	90003932023	2	波形弹性垫圈	Wave spiral washer
5	612600012280	1	管夹总成	Pipe Clamp Assembly
6	612600111639	2	管夹总成	Pipe Clamp Assembly
7	612600012595	1	回油管接头	Fuel return pipe nipple
8	90011350039	1	六角头螺栓	Hexagon bolt
9	90014010002	1	标准型弹簧垫圈	Single Coil Spring Lock Washer, Normal Type
10	612600013280	1	管夹总成	Pipe Clamp Assembly
11	612600012525	1	油路连接胶管	Oil Connecting Rubber Pipe
12	90003989340	1	卡箍	Clamp
13	90011430021	1	六角法兰面承面带齿螺栓	Hexagon Flange Bolt
14	90003989300	2	卡箍	Clamp

油气分离器总成(Oil-gas separator assembly)

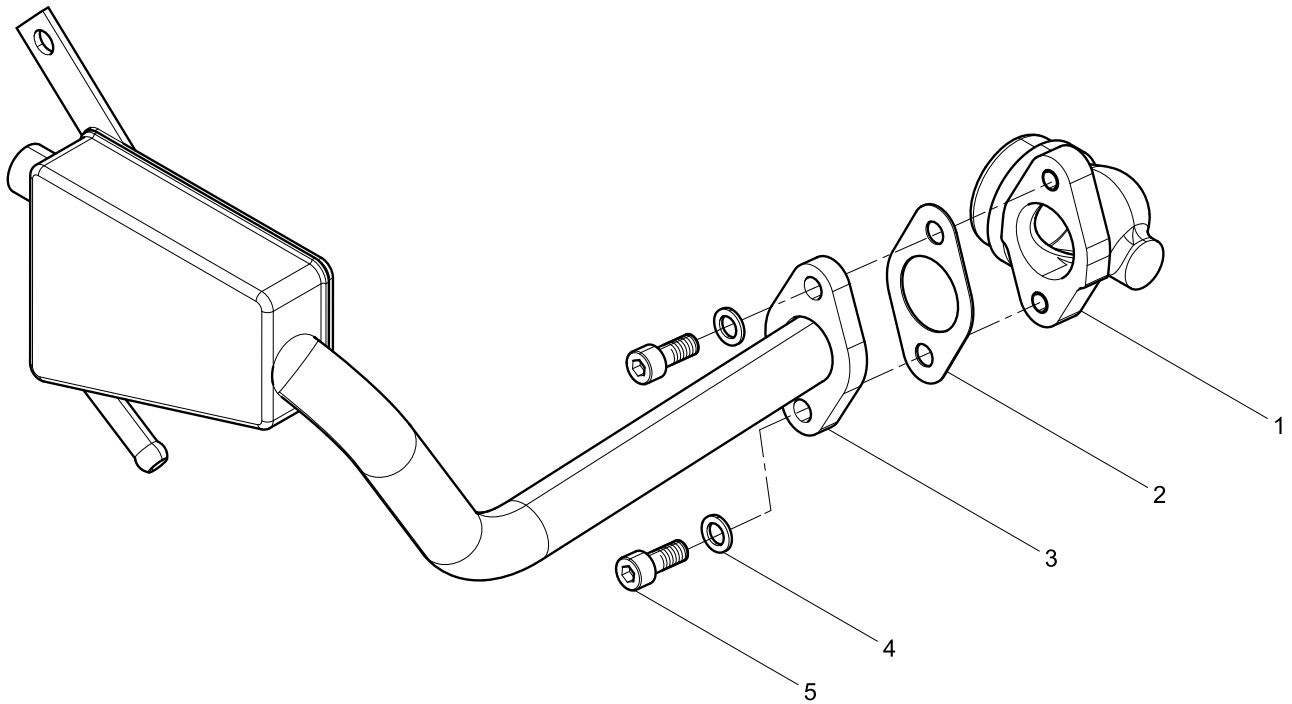

油气分离器总成(Oil-gas separator assembly)

图序号 Pos.	件号 Teile.Number	数量 Amount	中文名称 Denomination	英文名称 Designation
1	614010279	1	通风弯管	Ventilating elbow
2	90003069303	1	垫片	Gasket
3	612600011422	1	油气分离器组件	Oil-gas separator assembly
4	90003932023	2	波形弹性垫圈	Wave spiral washer
5	90003862427	2	内六角圆柱头螺钉	Inner hexagon screw

油尺结合组(Dipstick Group)

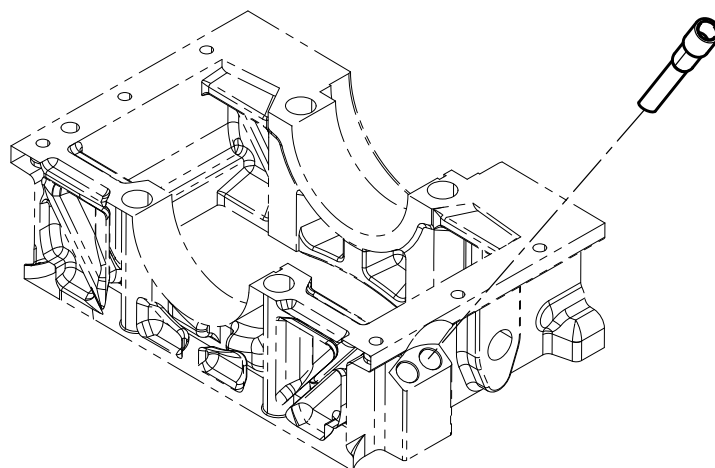
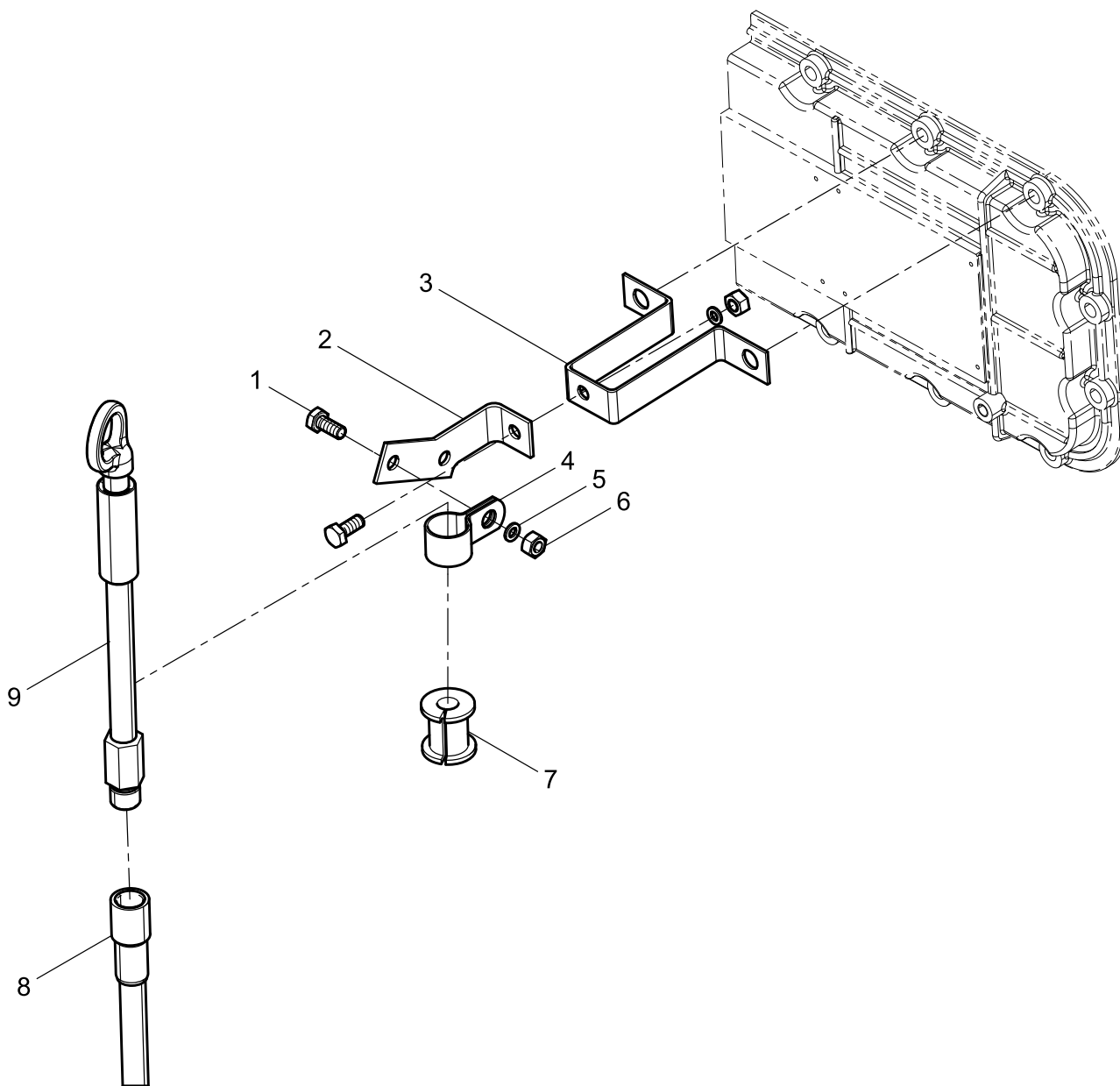

油尺结合组(Dipstick Group)

图序号 Pos.	件号 Teile.Number	数量 Amount	中文名称 Denomination	英文名称 Designation
1	90011350004	2	六角头螺栓	Hexagon bolt
2	612600010435	1	连接板	Connecting plate
3	612600010521	1	支架	Bracket
4	612600010647	1	单管夹片	Pipe clip
5	90014040006	2	平垫圈	Flat washer
6	90003871232	2	1型六角螺母	Hexagon nut (I)
7	612600010638	1	橡胶管箍	Rubber clip
8	612600012691	1	油标尺总成	Oil dipstick assembly
9	612600012639	1	油尺管下组件	Oil dipstick tube assembly (lower)

油标尺总成(Oil dipstick assembly)

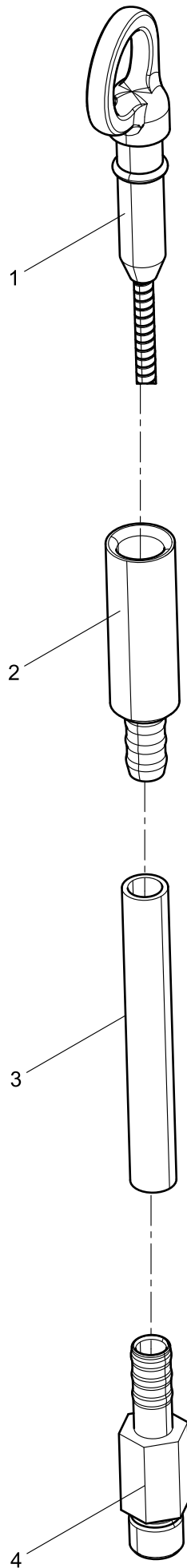

加油管结合组(Oil Tilling Tube Group)

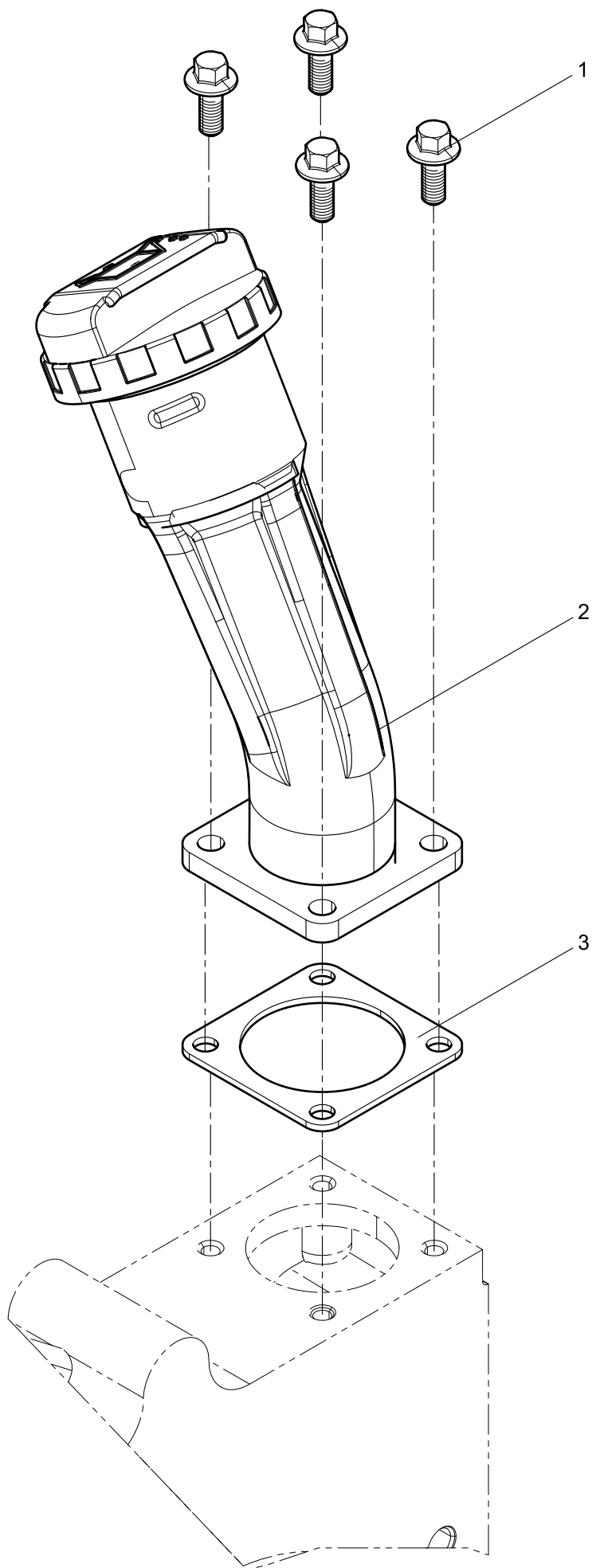

飞轮壳结合组(Flywheel Housing Group)

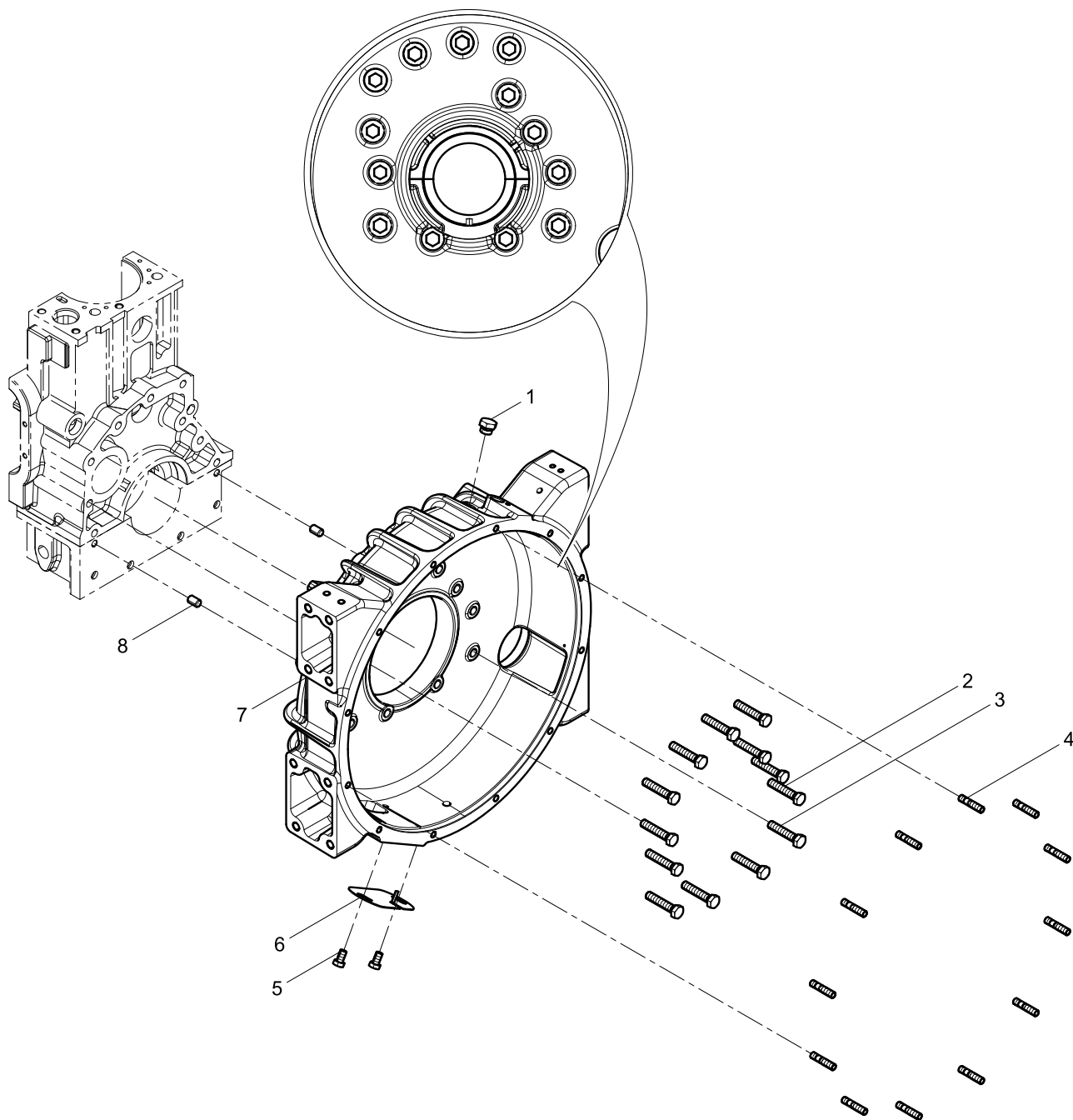

飞轮壳结合组(Flywheel Housing Group)

图序号 Pos.	件号 Teile.Number	数量 Amount	中文名称 Denomination	英文名称 Designation
1	90003962030	1	六角螺塞	Hexagon plug
2	61500010062	7	飞轮壳螺栓	Flywheel housing bolt
3	61500010101	6	飞轮壳螺栓	Flywheel housing bolt
4	90003813537	12	双头螺柱	Stud
5	90003802511	2	六角头螺栓	Hexagon bolt
6	612630030066	1	观察孔盖板	Inspection window cover
7	612600013611	1	飞轮壳	Flywheel housing
8	90003901604	2	圆柱销	Straight pin

机油冷却器盖组件()

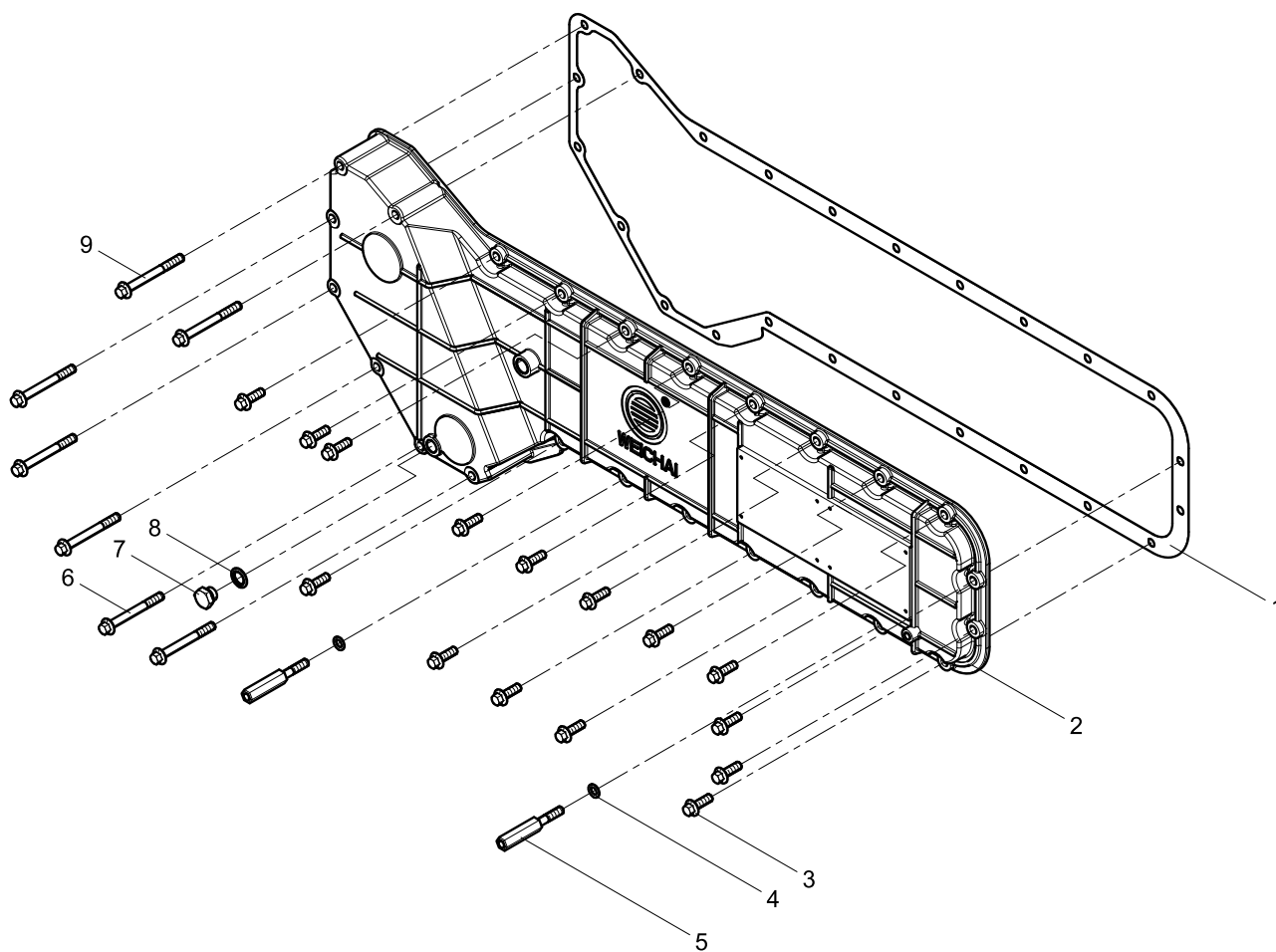

机油冷却器盖组件()

图序号 Pos.	件号 Teile.Number	数量 Amount	中文名称 Denomination	英文名称 Designation
1	614010084B	1	机油冷却器盖垫片	Oil cooler cover gasket
2	614010083B	1	机油冷却器盖	Oil cooler cover
3	90011410003	15	六角法兰面螺栓	Hexagon Flange Bolt
4	90003932023	2	波形弹性垫圈	Wave spiral washer
5	612600010626	2	支撑块	Supporting plate
6	90011410009	5	六角法兰面螺栓	Hexagon Flange Bolt
7	90003962020	1	六角螺塞	Hexagon plug
8	612600080200	1	密封垫圈	Seal washer
9	90011410010	2	六角法兰面螺栓	Hexagon Flange Bolt

飞轮结合组(Flywheel Group)

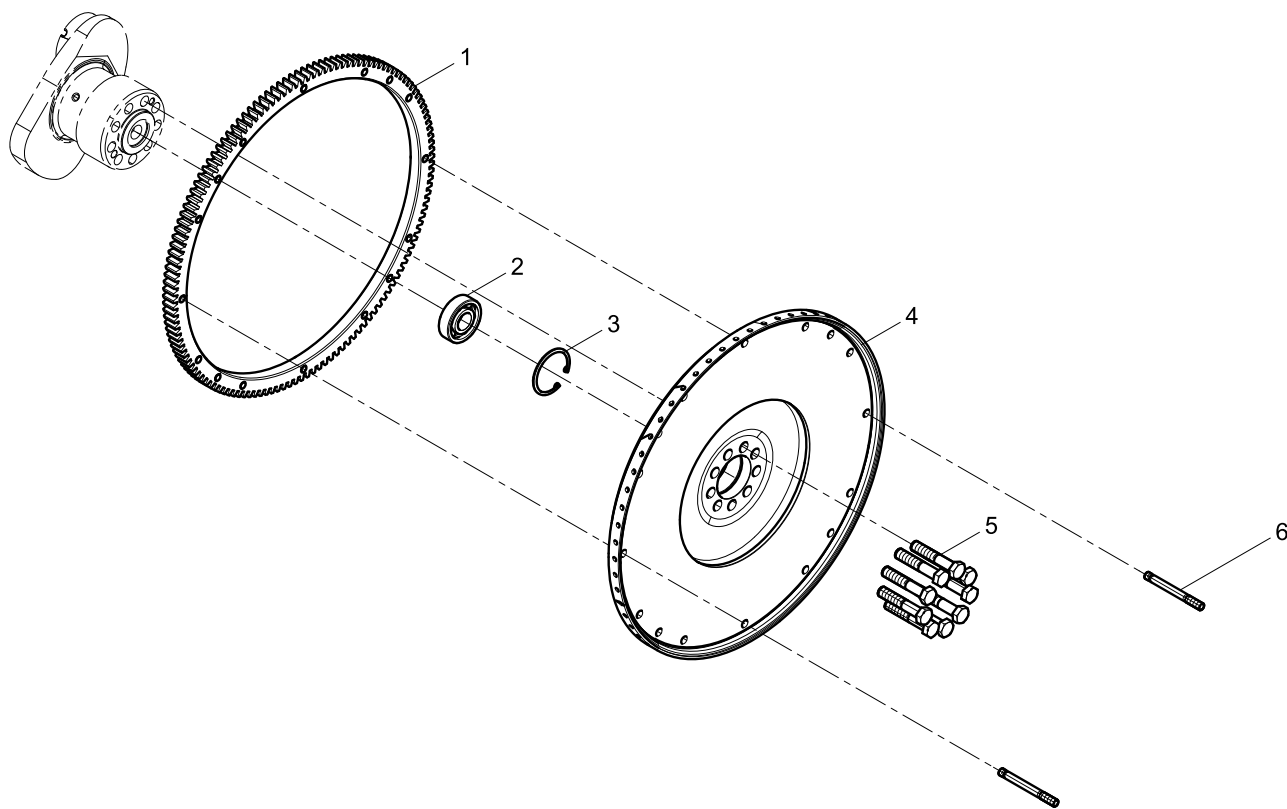

飞轮结合组(Flywheel Group)

图序号 Pos.	件号 Teile.Number	数量 Amount	中文名称 Denomination	英文名称 Designation
1	612600020208	1	飞轮齿圈	Flywheel ring gear
2	90003311416	1	向心球轴承	Centripetal ball bearing
3	90003934310	1	孔用弹性档圈	Circlip for hole
4	612600020354	1	飞轮	Flywheel
5	61500020046	9	六角头螺栓	Hexagon bolt
6	90003813571	2	双头螺柱	Stud

曲轴皮带轮结合组(Crankshaft Pulley Group)

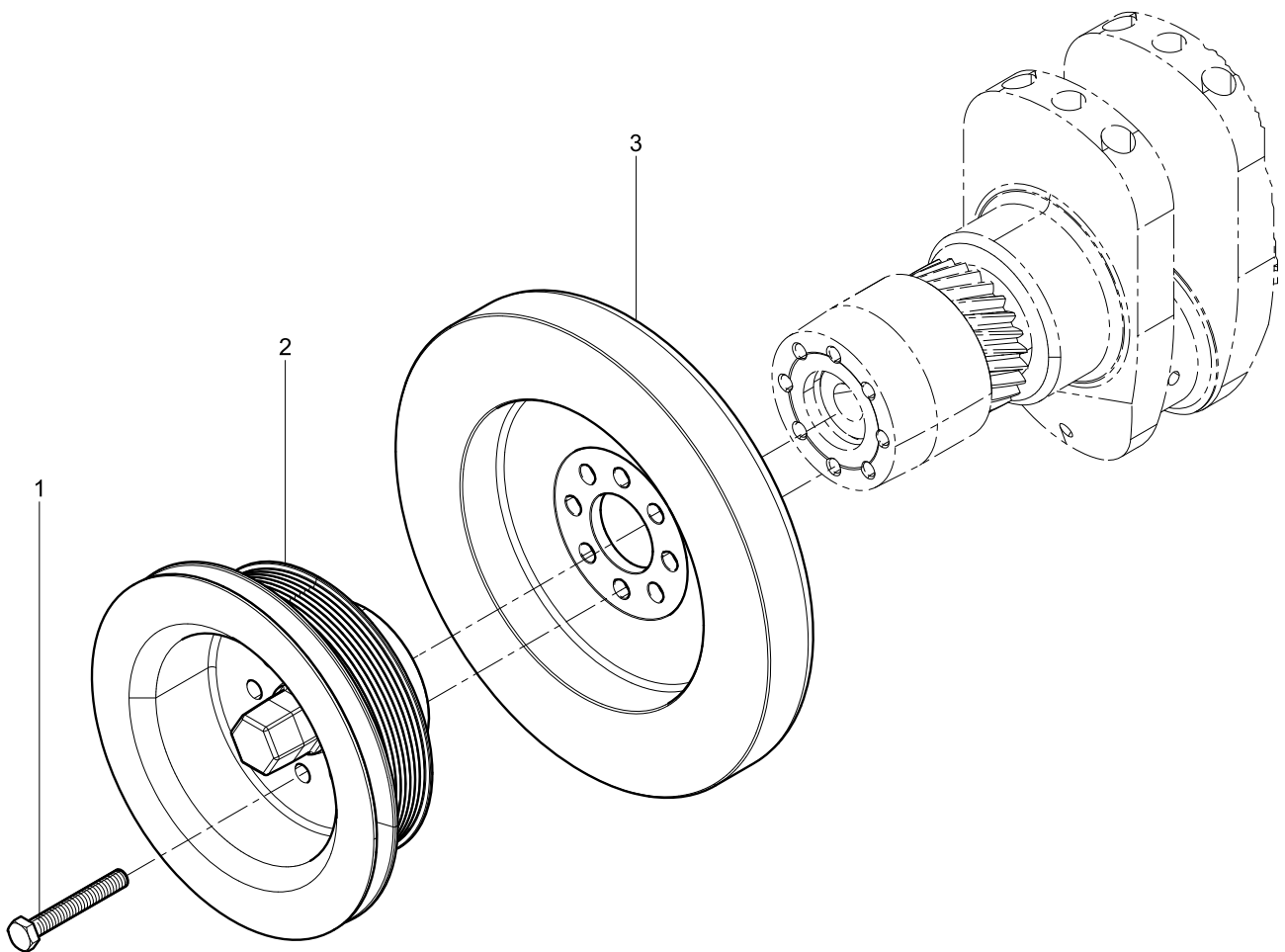

气缸盖罩组件0

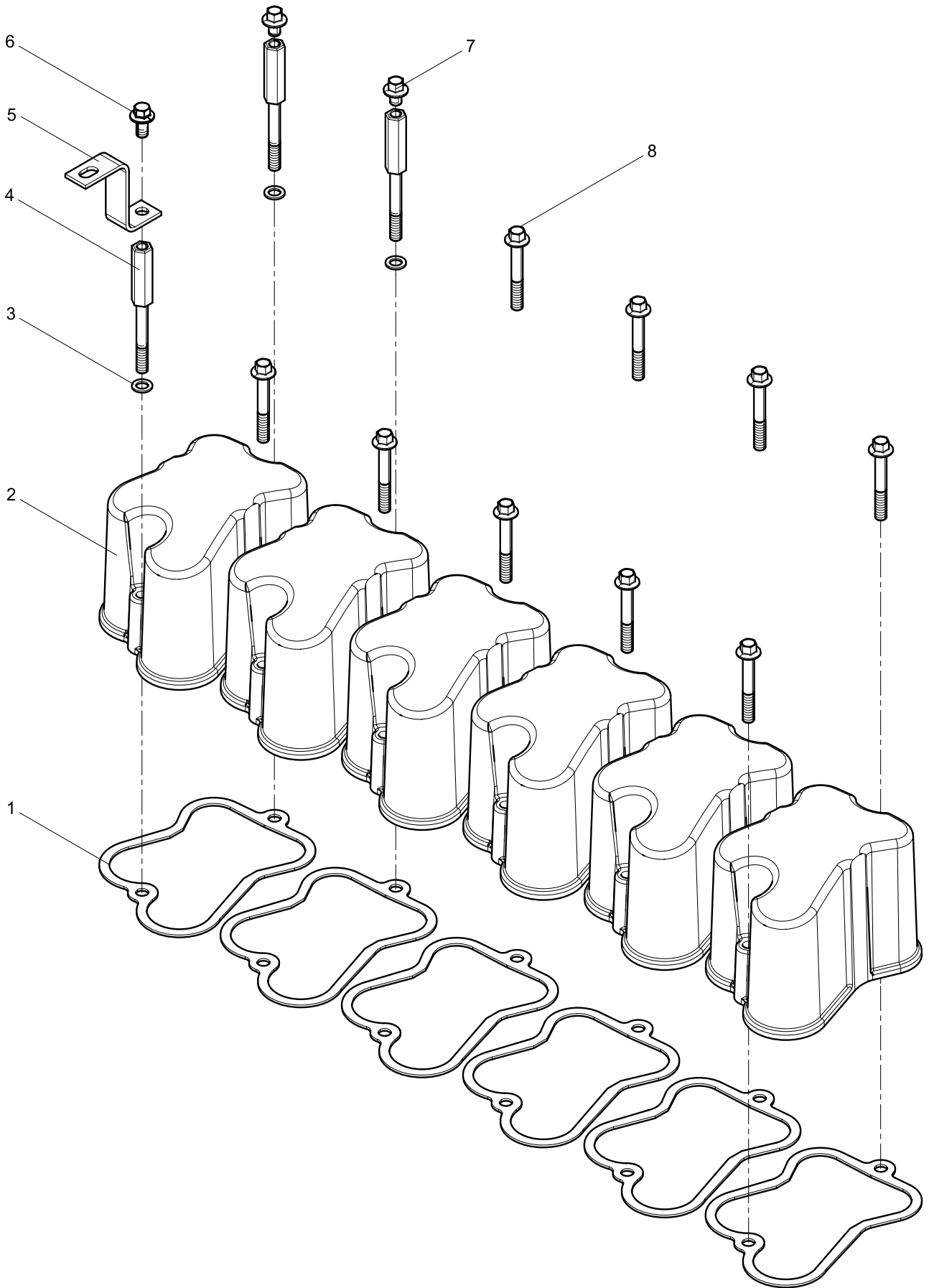

气缸盖罩组件()

图序号 Pos.	件号 Teile.Number	数量 Amount	中文名称 Denomination	英文名称 Designation
1	614040021	6	气缸盖罩衬垫	Cylinder head cover gasket
2	612600040149	6	气缸盖罩	Cylinder head cover
3	90003932023	3	波形弹性垫圈	Wave spiral washer
4	612600040259	3	支撑块	Supporting plate
5	612600040385	1	支架	Bracket
6	90011430040	1	六角法兰面承面带齿螺栓	Hexagon Flange Bolt
7	612600114377	2	六角法兰面承面带齿螺栓	Hexagon Flange Bolt
8	612600040636	9	六角法兰面螺栓	Hexagon Flange Bolt

出水管结合组(Water Outlet Pipe Group)

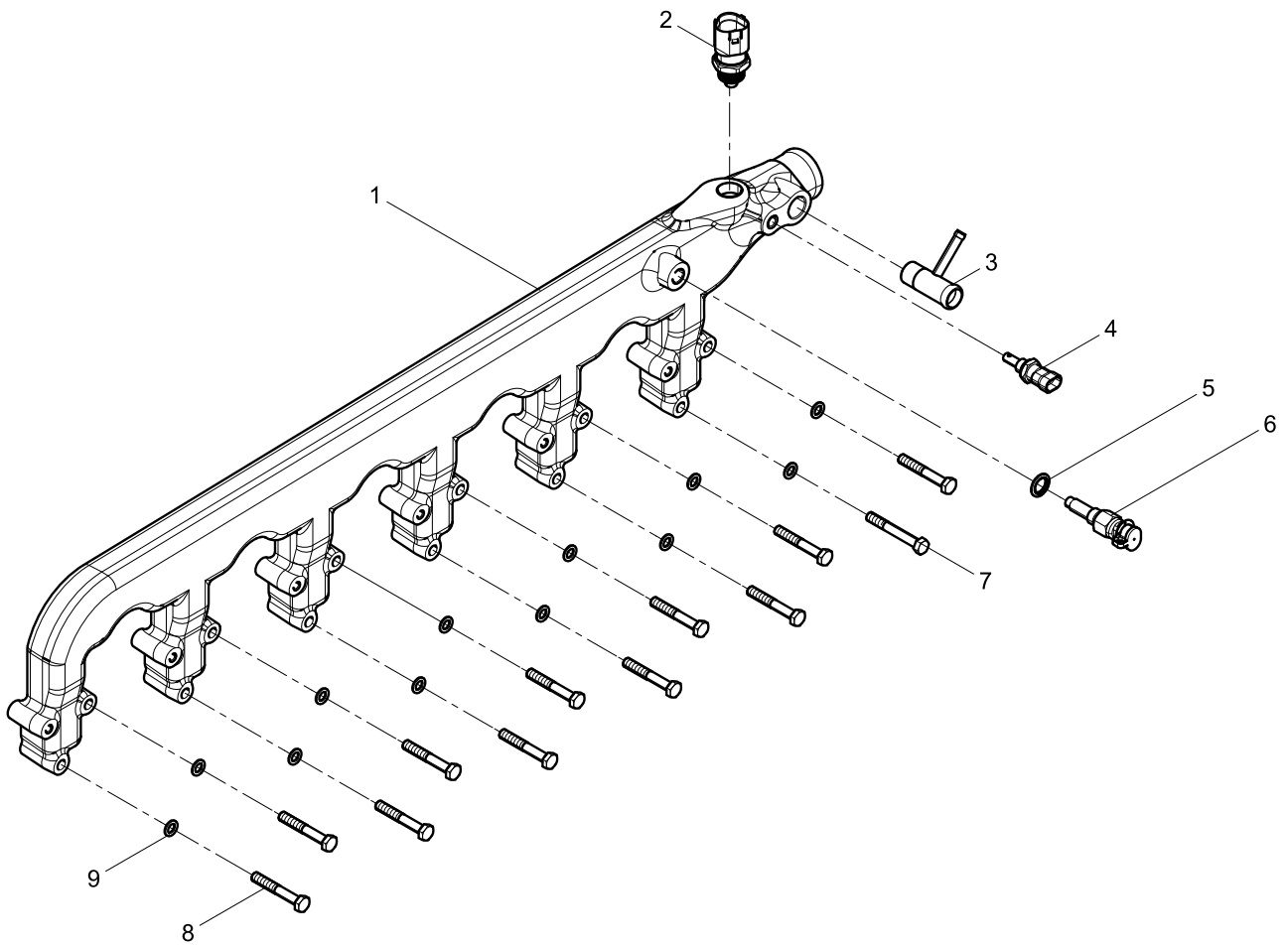

节温器结合组(Thermostat Group)

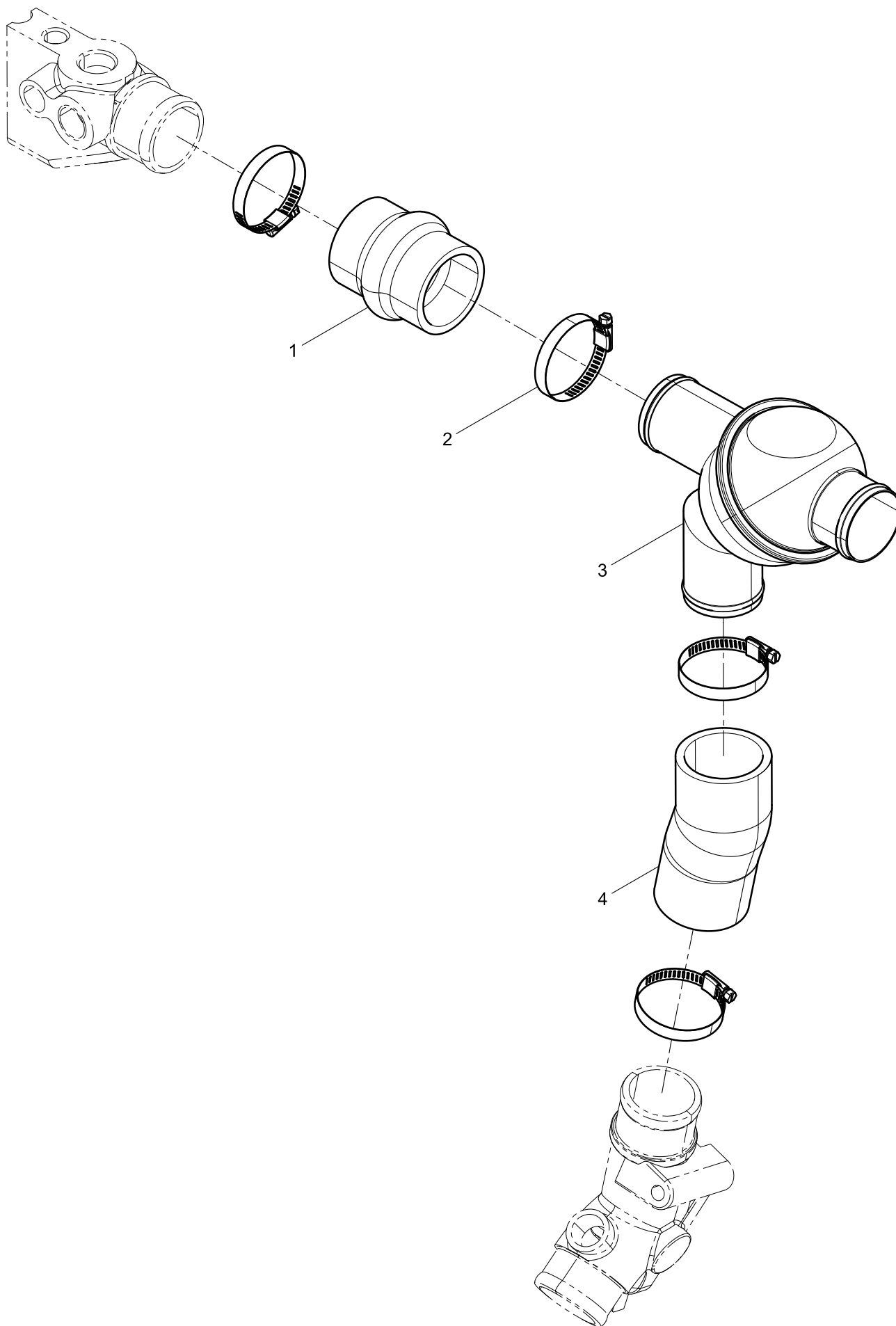

水泵结合组(Water pump assembly)

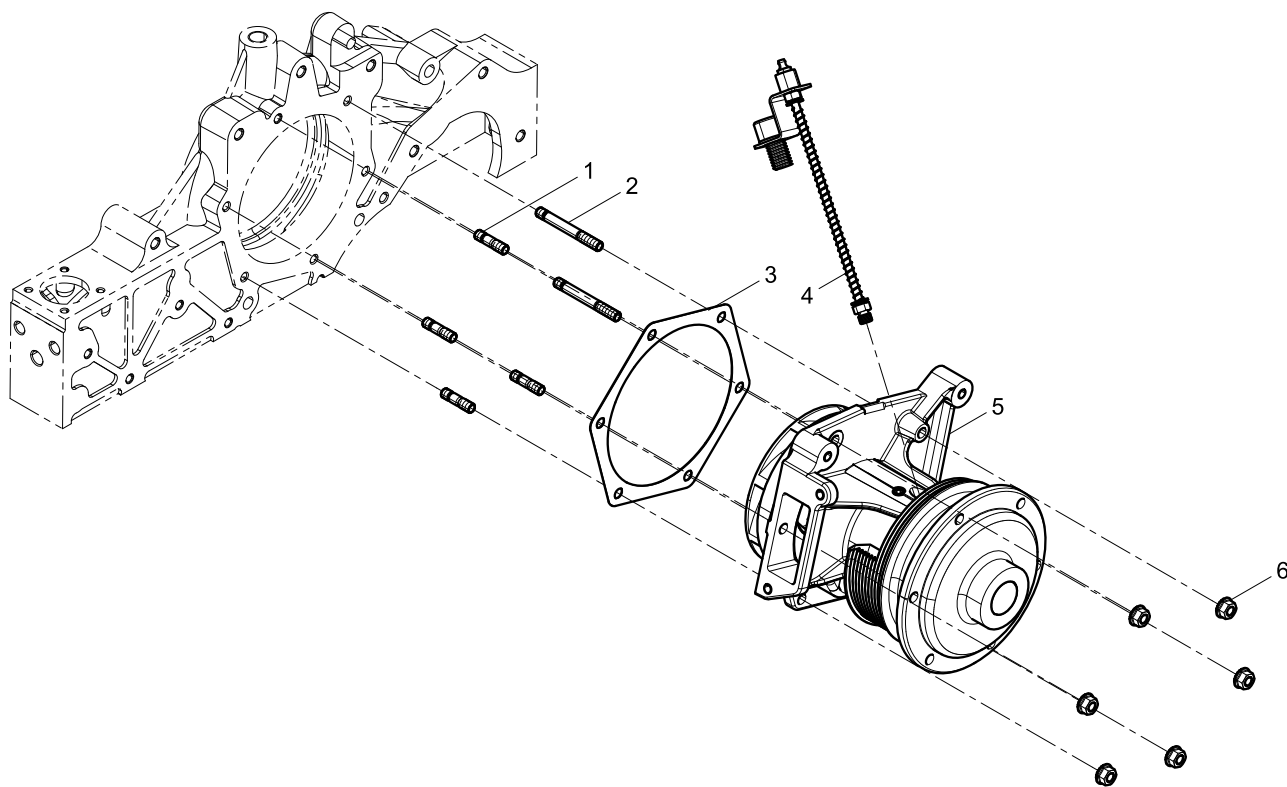

水泵结合组(Water pump assembly)

图序号 Pos.	件号 Teile.Number	数量 Amount	中文名称 Denomination	英文名称 Designation
1	90003813429S	4	双头螺柱	Stud
2	90003813471S	2	双头螺柱	Stud
3	614060008	1	水泵密封垫	Seal gasket of water pump
4	612600061396	1	水泵加黄油装置	Adding butter thingamy of water pump
5	612600061603	1	水泵总成	Water pump assembly
6	612600061719	6	六角法兰面承面带齿螺母	Hexagon Flange Nut

水管接头结合组(Water Pipe Connector Group)

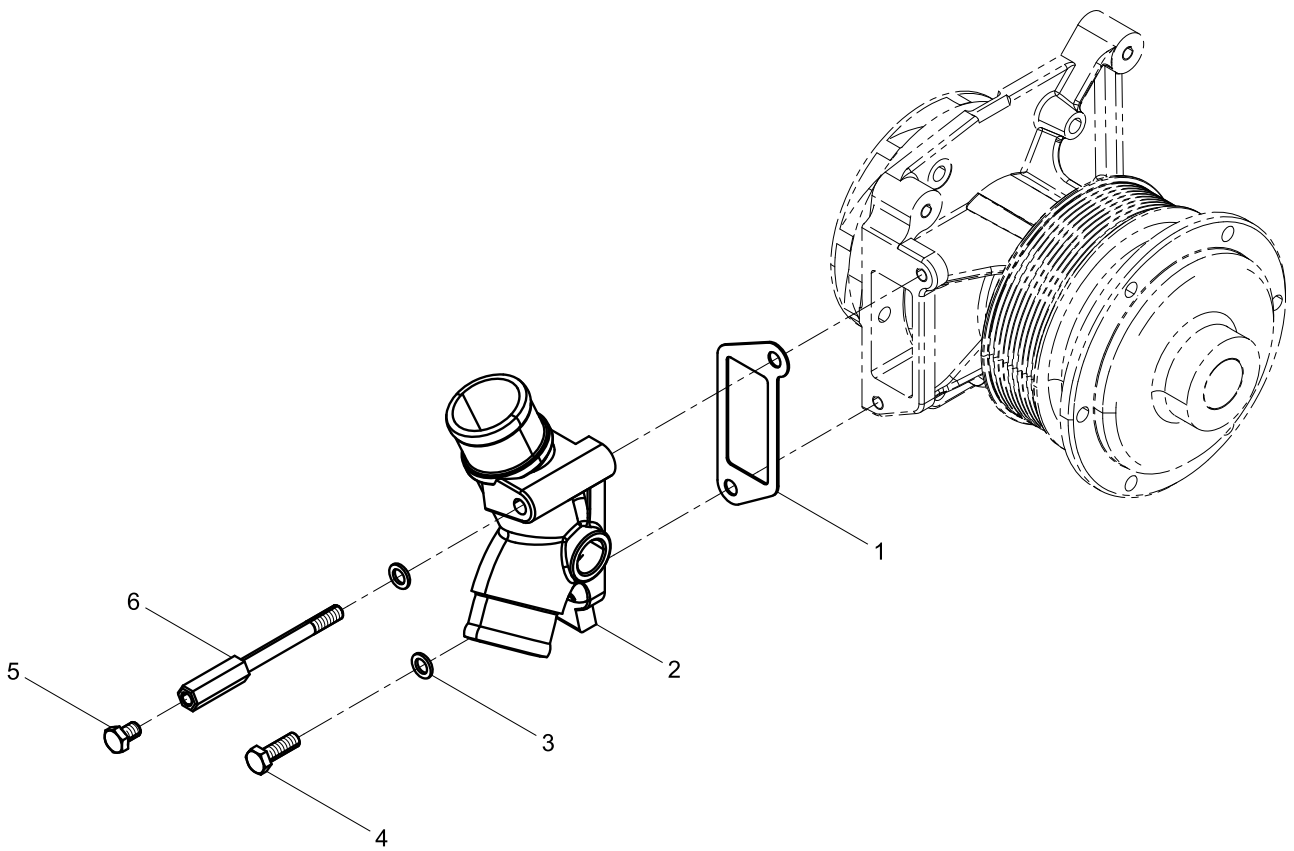

风扇及轮毂结合组(Fan and Hub Group)

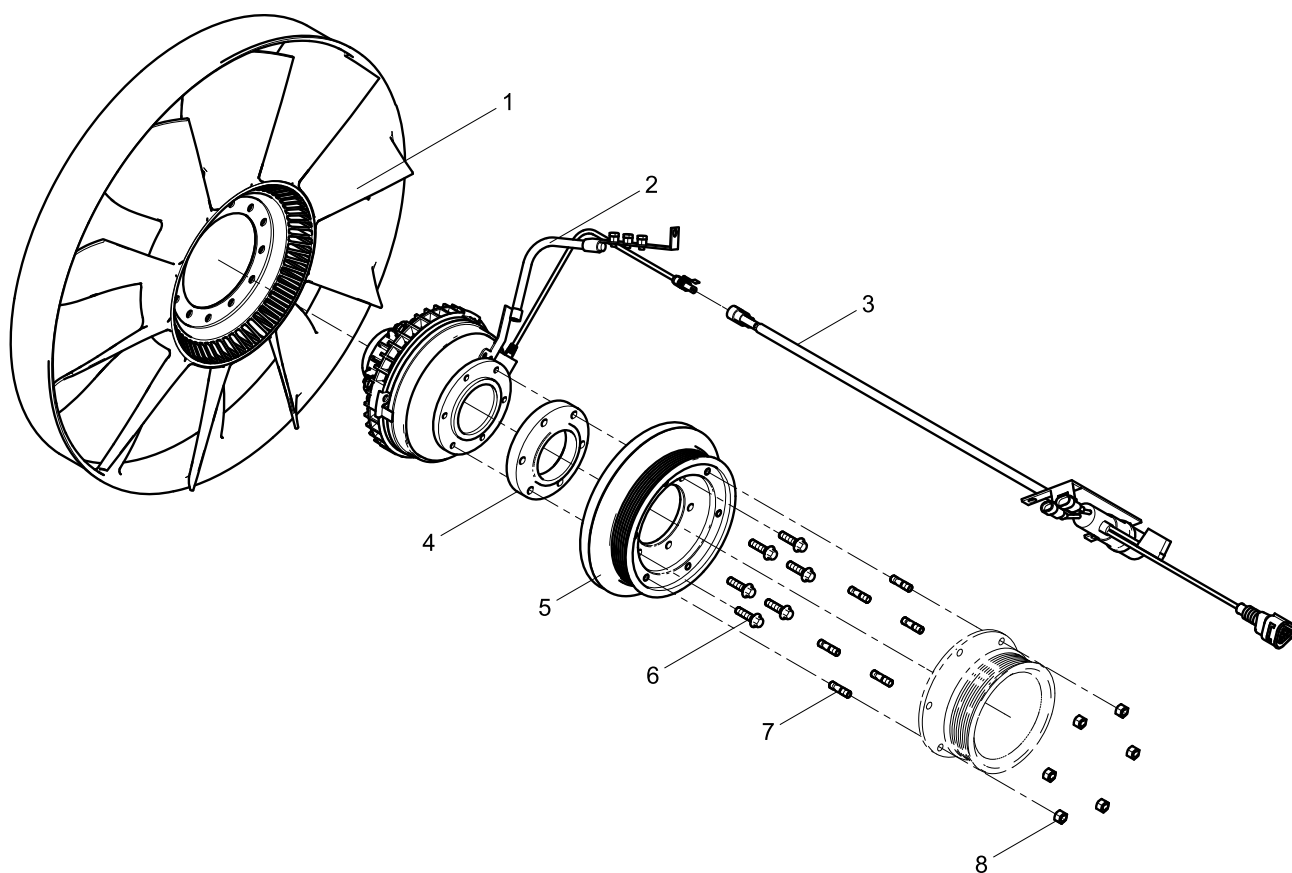

风扇及轮毂结合组(Fan and Hub Group)

图序号 Pos.	件号 Teile.Number	数量 Amount	中文名称 Denomination	英文名称 Designation
1	612600060445	1	风扇	Fan
2	612600061489	1	风扇离合器	Fan Clutch
3	612600061658	1	风扇离合器线束	Fan Clutch Harness
4	612600061480	1	风扇连接盘	Connecting disk of fan
5	612600061470	1	皮带轮	Belt pulley
6	90011430018	6	六角法兰面承面带齿螺栓	Hexagon Flange Bolt
7	90003813423S	6	双头螺柱	Stud
8	90003888451	6	2型全金属六角锁紧螺母	Prevailing Torque Type All-metal Hexagon Nut,

涨紧轮及皮带结合组()

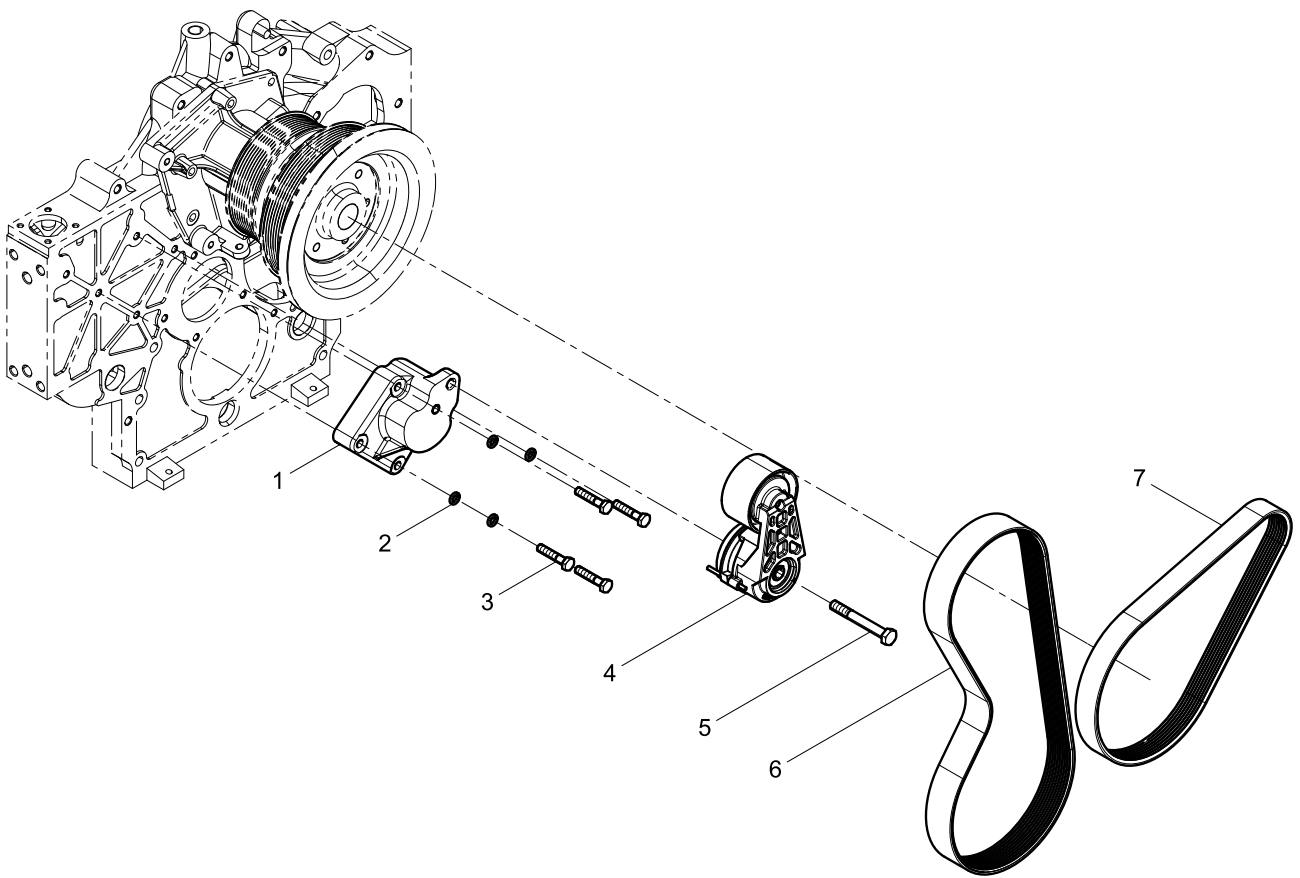

机油集滤器结合组(Oil Suction Strainer Group)

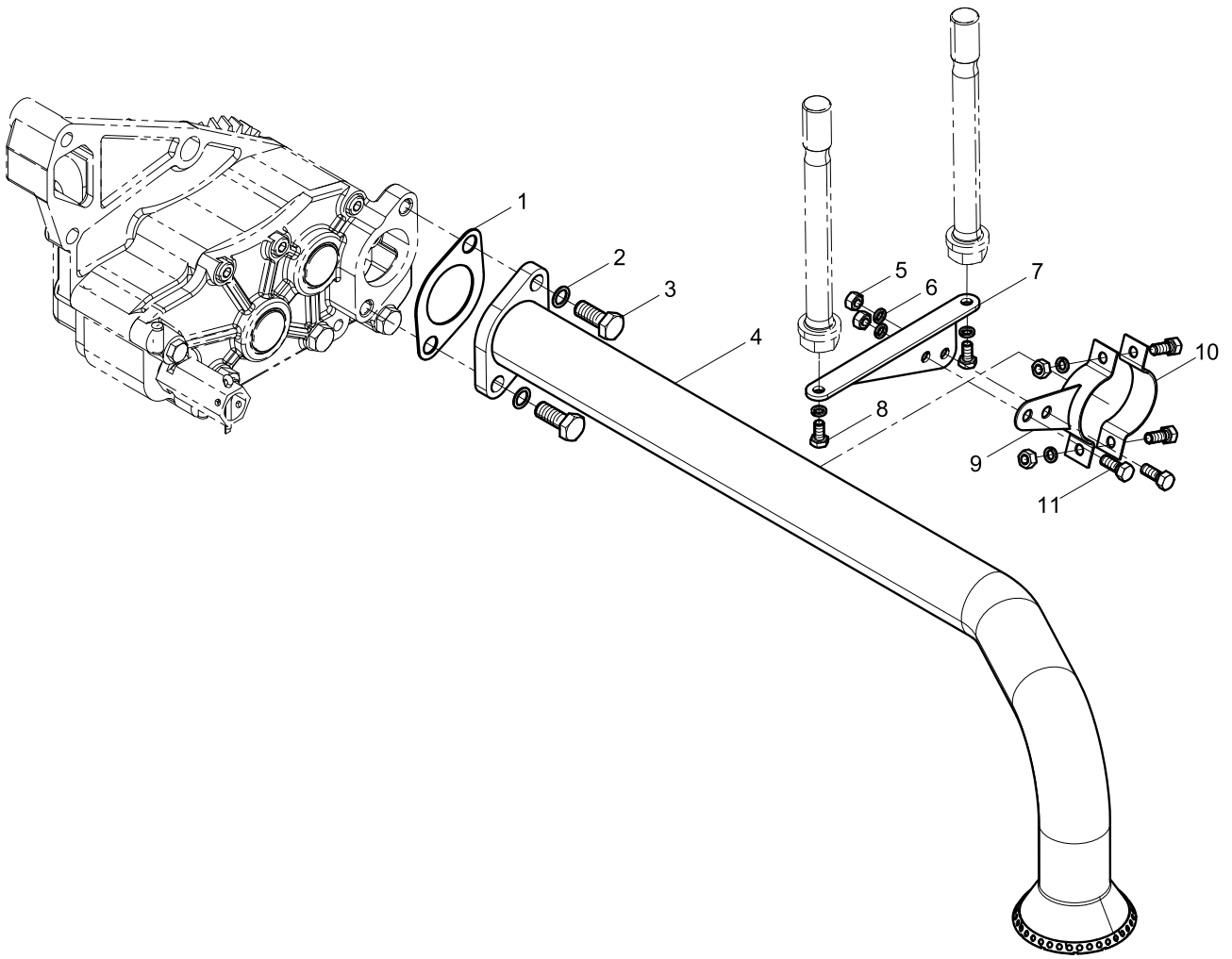

机油集滤器结合组(Oil Suction Strainer Group)

图序号 Pos.	件号 Teile.Number	数量 Amount	中文名称 Denomination	英文名称 Designation
1	612600070001	1	垫片	Gasket
2	90003930271	2	平垫圈	Flat washer
3	90003802523S	2	六角头螺栓	Hexagon bolt
4	612600070296	1	集滤器总成	Strainer assembly
5	90003871232	4	1型六角螺母	Hexagon nut (I)
6	90014350003	6	弹簧垫圈	Spring washer
7	612600070023	1	机油集滤器支架	Oil Suction Strainer Bracket
8	90003802312	2	六角头螺栓	Hexagon bolt
9	612600070024	1	小支架	Bracket
10	612600070025	1	压板	Clamp plate
11	90003802321	4	六角头螺栓	Hexagon bolt

机油滤清器结合组(Oil filter assembly)

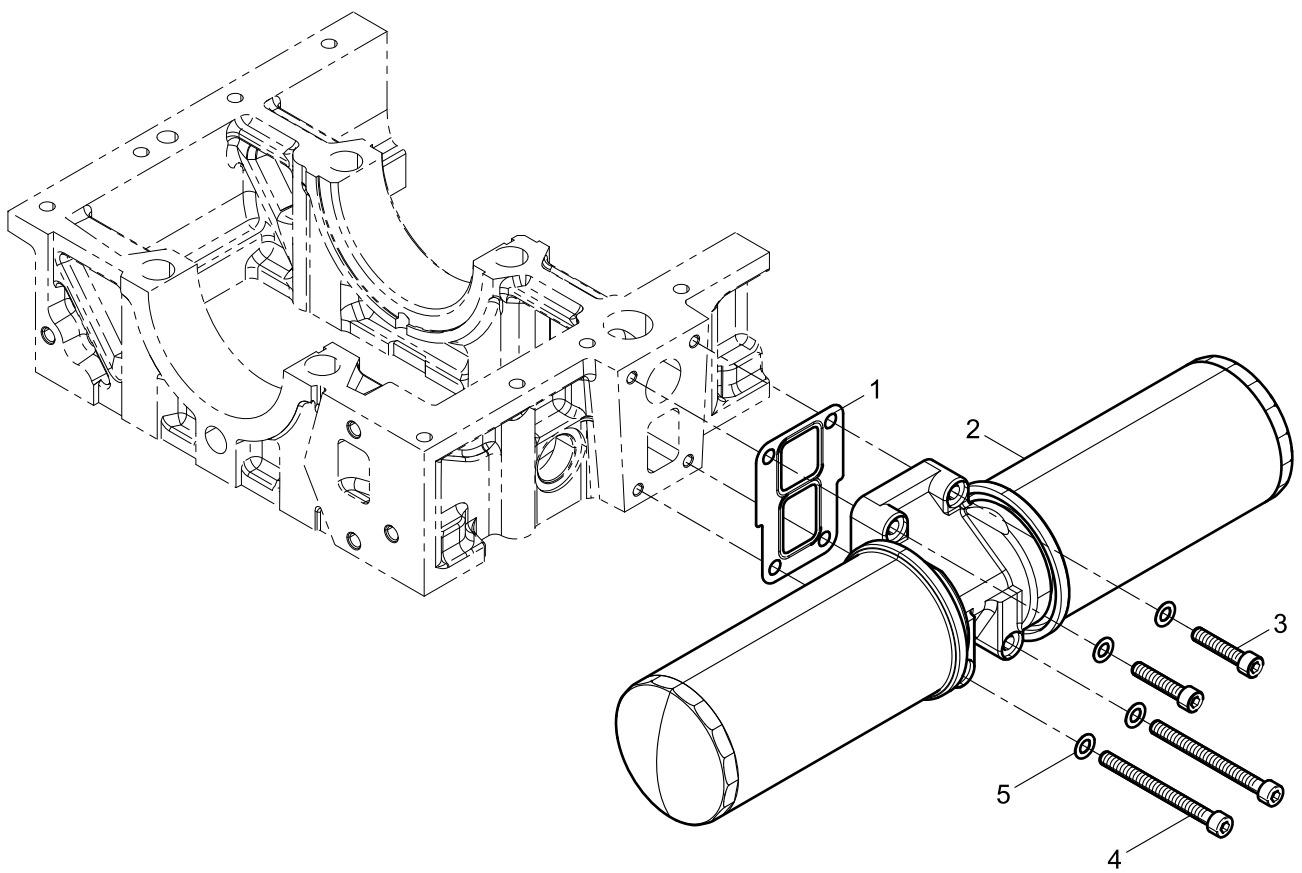

机油滤清器总成(Oil filter assembly)

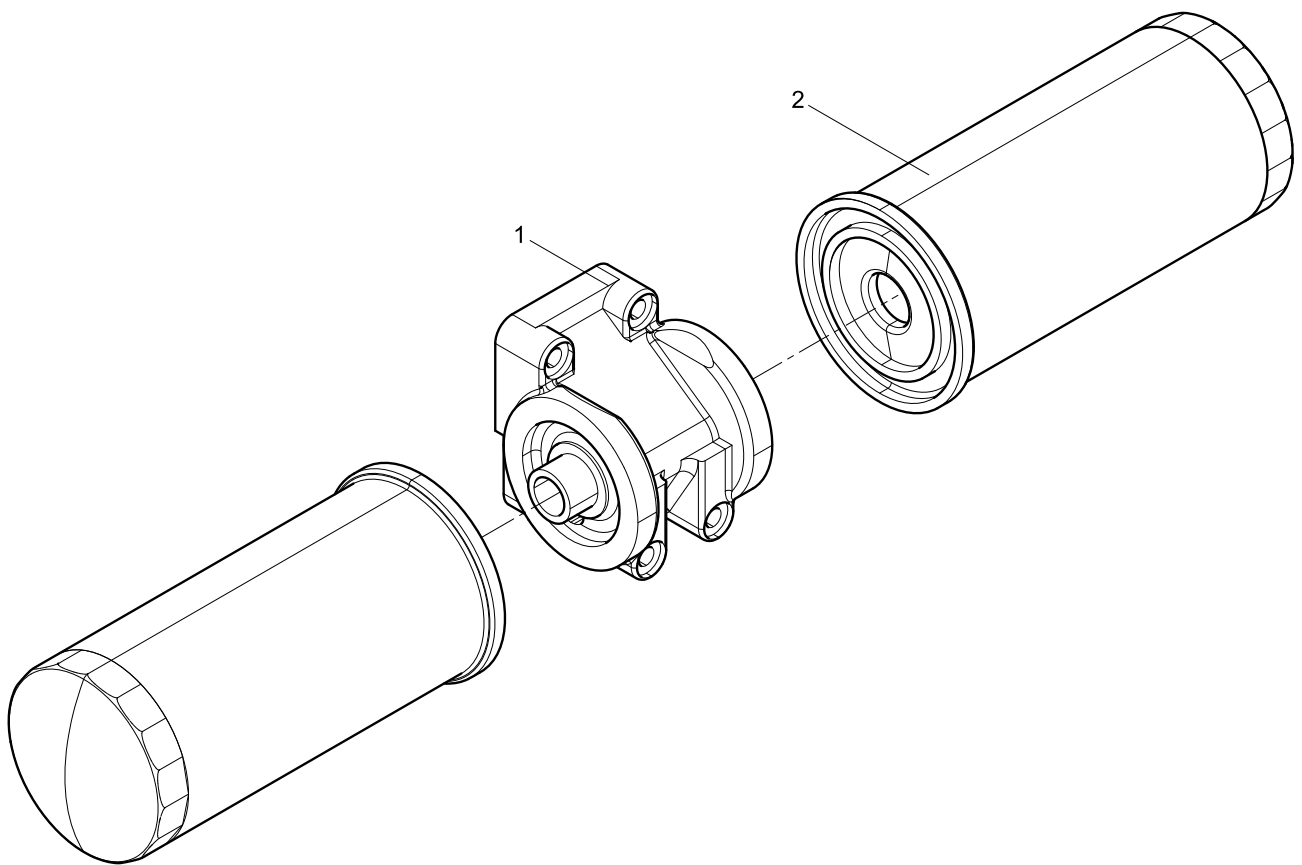

燃油滤清器结合组(Fuel Filter Group)

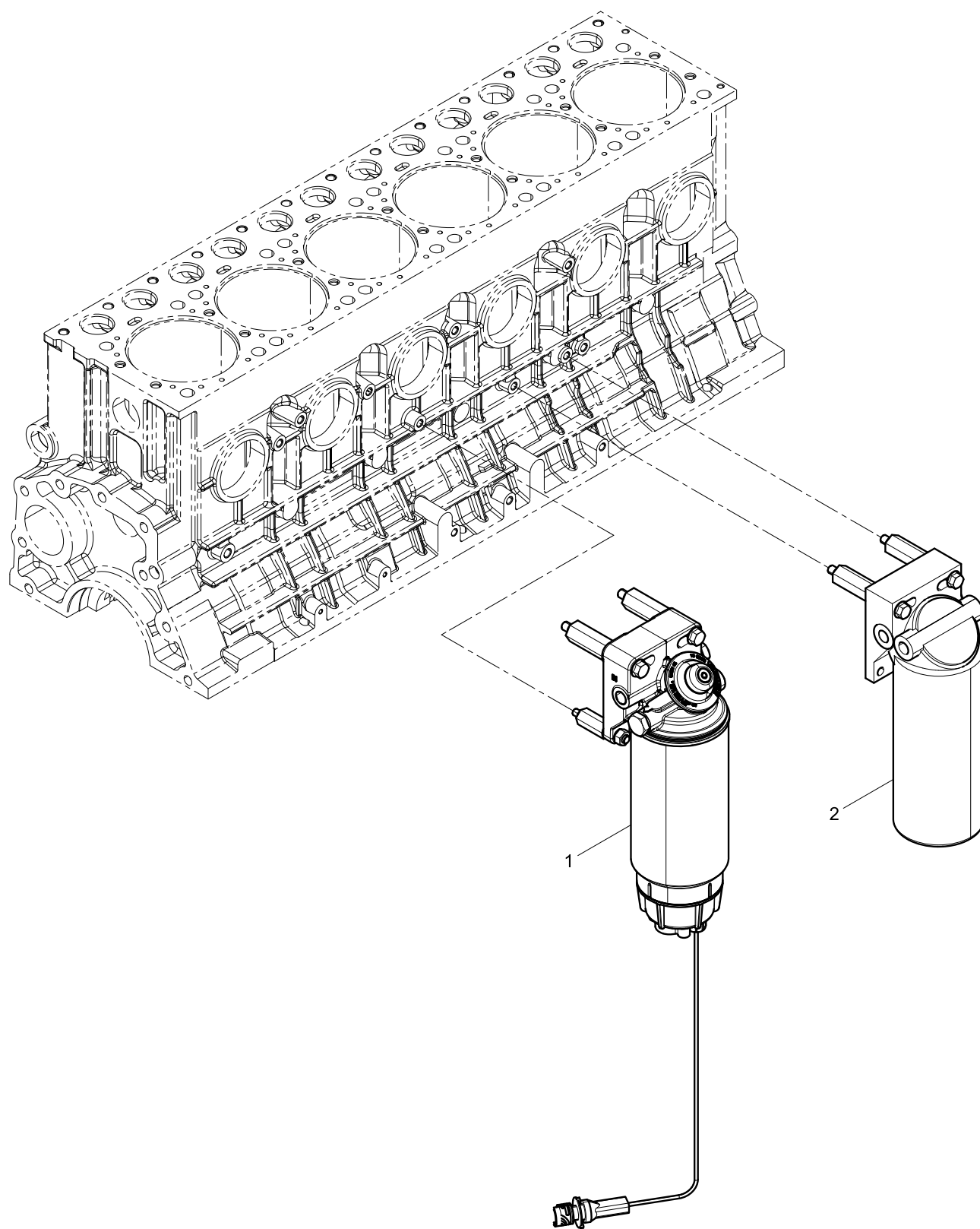

燃油滤清器结合组(Fuel Filter Group)

图序号 Pos.	件号 Teile.Number	数量 Amount	中文名称 Denomination	英文名称 Designation
1	612600081472	1	燃油粗滤器组件	
2	612600081473	1	燃油精滤器组件	

燃油精滤器组件()

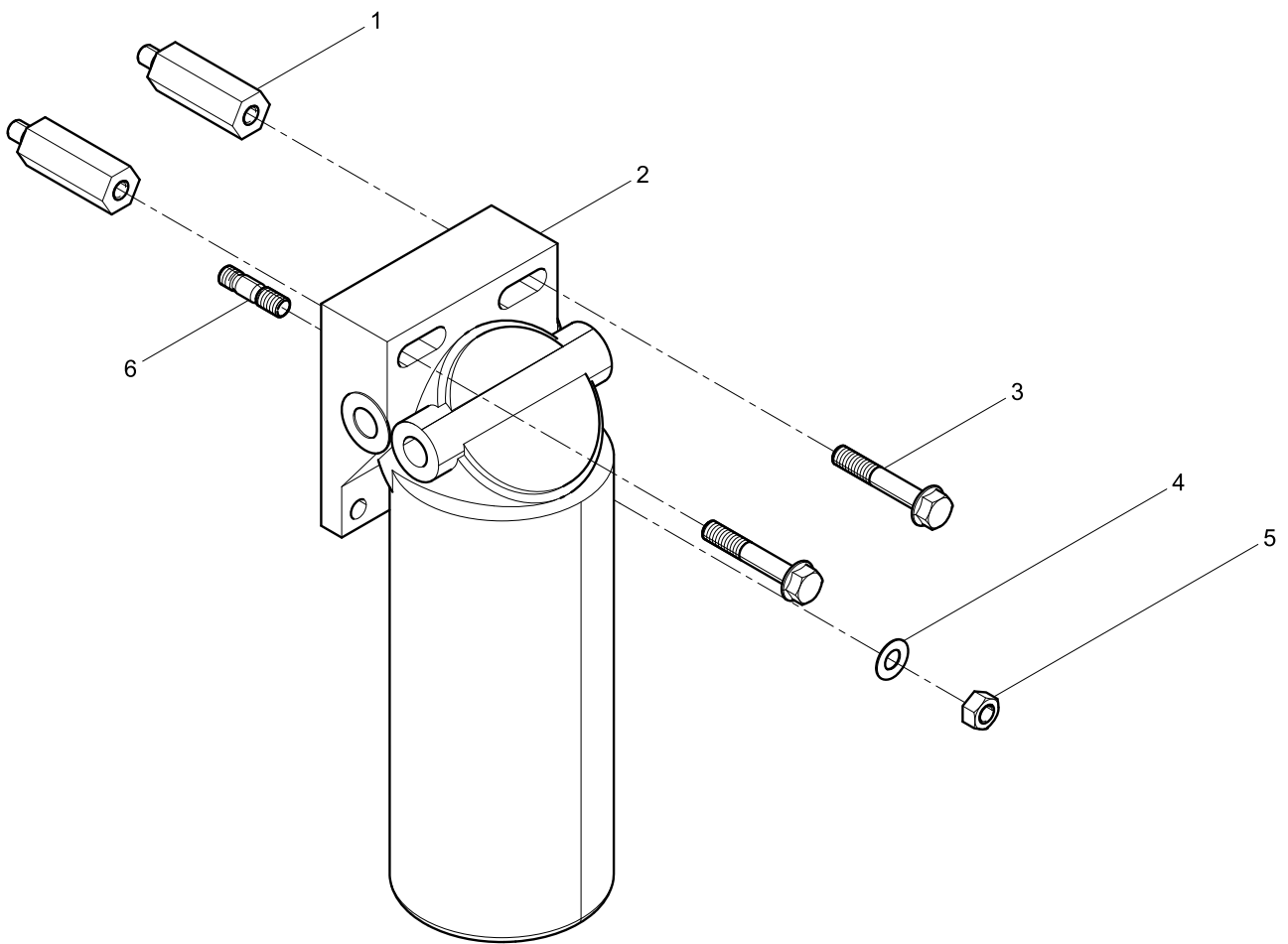

燃油精滤器组件()

图序号 Pos.	件号 Teile.Number	数量 Amount	中文名称 Denomination	英文名称 Designation
1	612600081503	2	螺钉	Screw
2	612630080011	1	精滤器	Fine filter
3	612639000090	2	六角头螺栓	Hexagon bolt
4	90003932024	1	波形弹性垫圈	Wave spiral washer
5	90003871305	1	1型六角螺母	Hexagon nut (I)
6	612600083177	1	双头螺柱	Stud

精滤器(Fine filter)

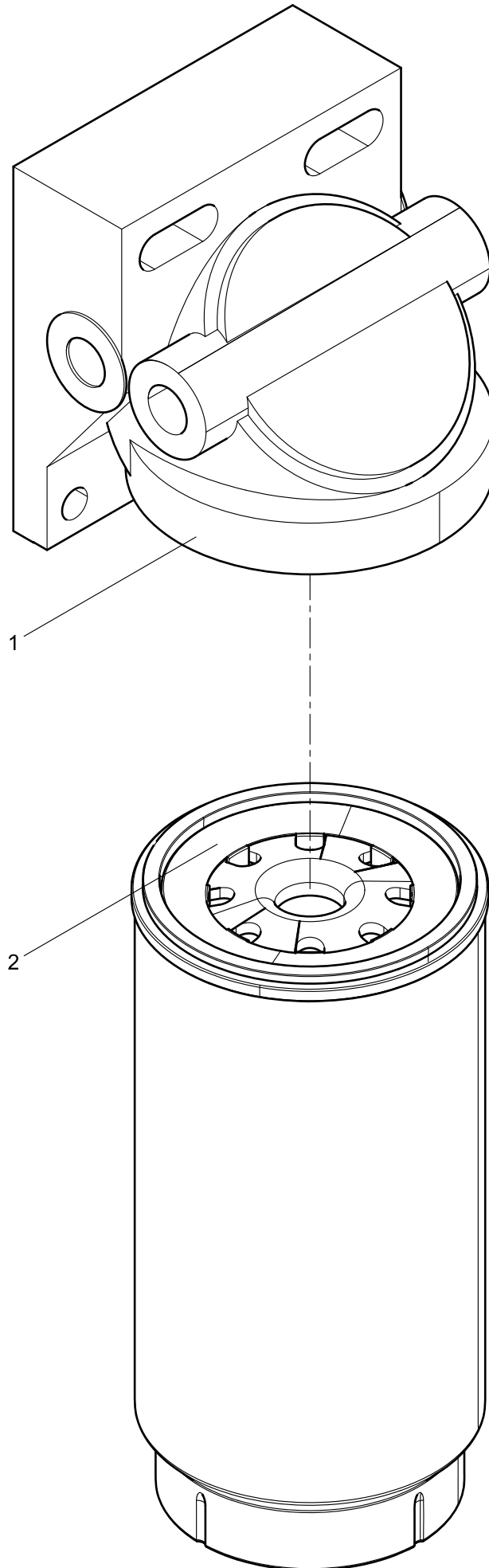

燃油粗滤器组件()

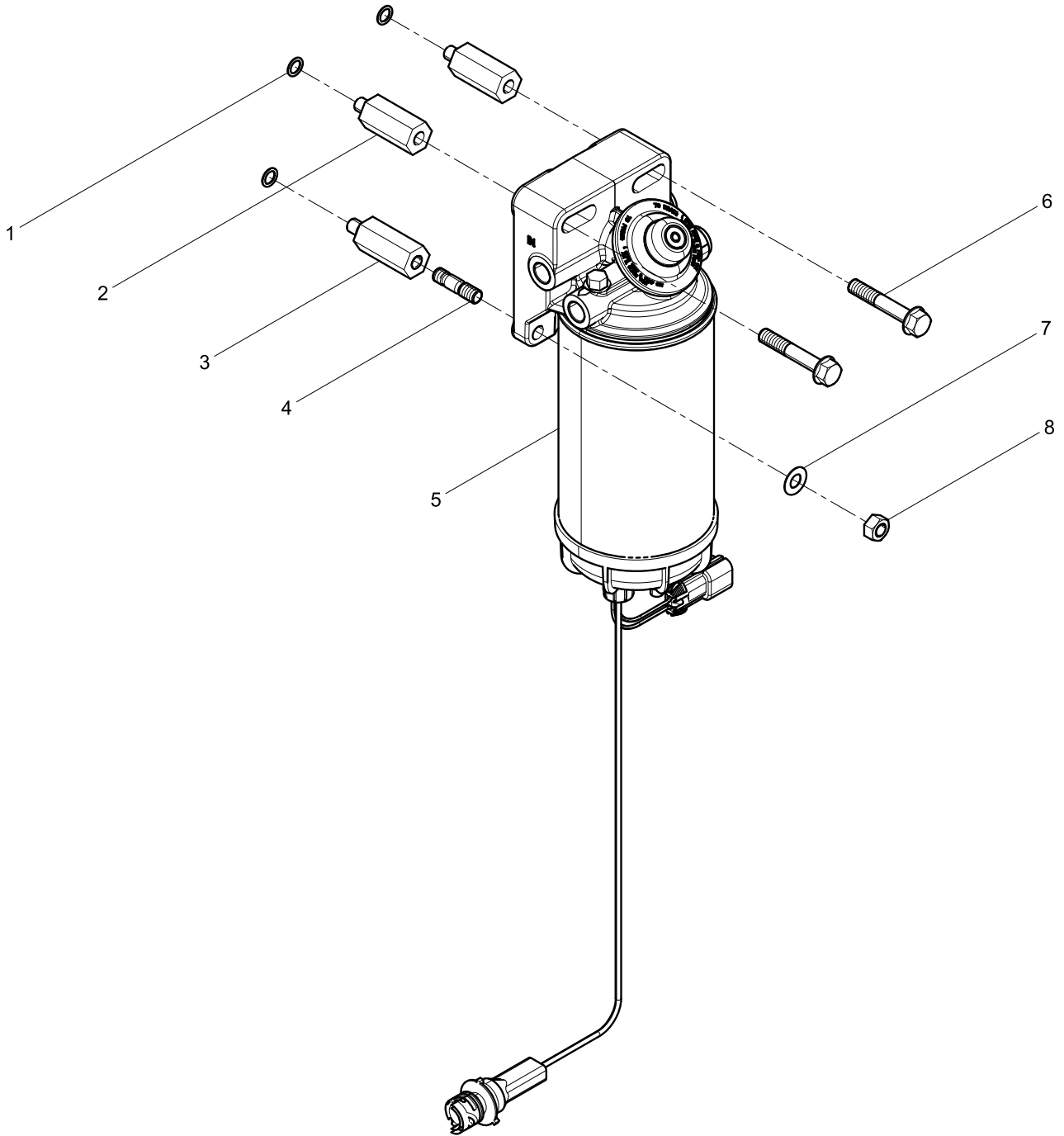

燃油粗滤器组件()

图序号 Pos.	件号 Teile.Number	数量 Amount	中文名称 Denomination	英文名称 Designation
1	90003930271	3	平垫圈	Flat washer
2	612600080668	2	螺钉	Screw
3	612600081502	1	螺钉	Screw
4	90003813527	1	双头螺柱	Stud
5	612630080123	1	燃油粗滤器	Primary fuel filter
6	612639000090	2	六角头螺栓	Hexagon bolt
7	90003932024	1	波形弹性垫圈	Wave spiral washer
8	90003871305	1	1型六角螺母	Hexagon nut (I)

燃油粗滤器(Primary fuel filter)

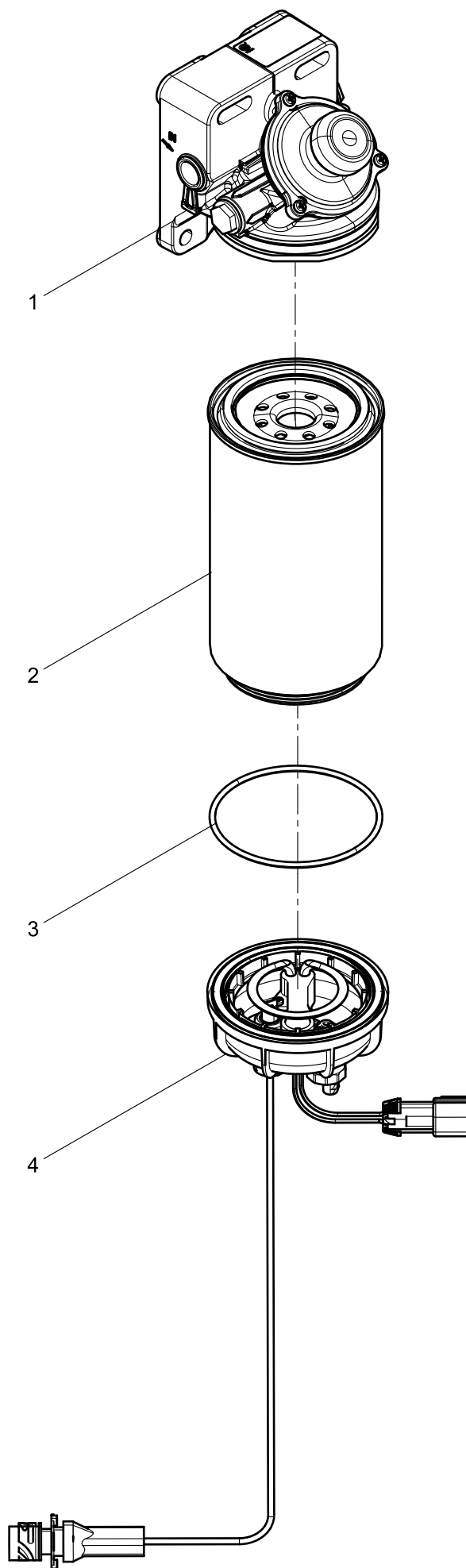

燃油粗滤器(Primary fuel filter)

图序号 Pos.	件号 Teile.Number	数量 Amount	中文名称 Denomination	英文名称 Designation
1	612630080371	1	滤座组件	
2	612630080088	1	燃油粗滤芯	Element of primary fuel filter
3	612600081327	1	密封圈	Seal washer
4	612630080373	1	水杯总成	Cup Assembly

低压油管结合组(Low Pressure Oil pipe Group)

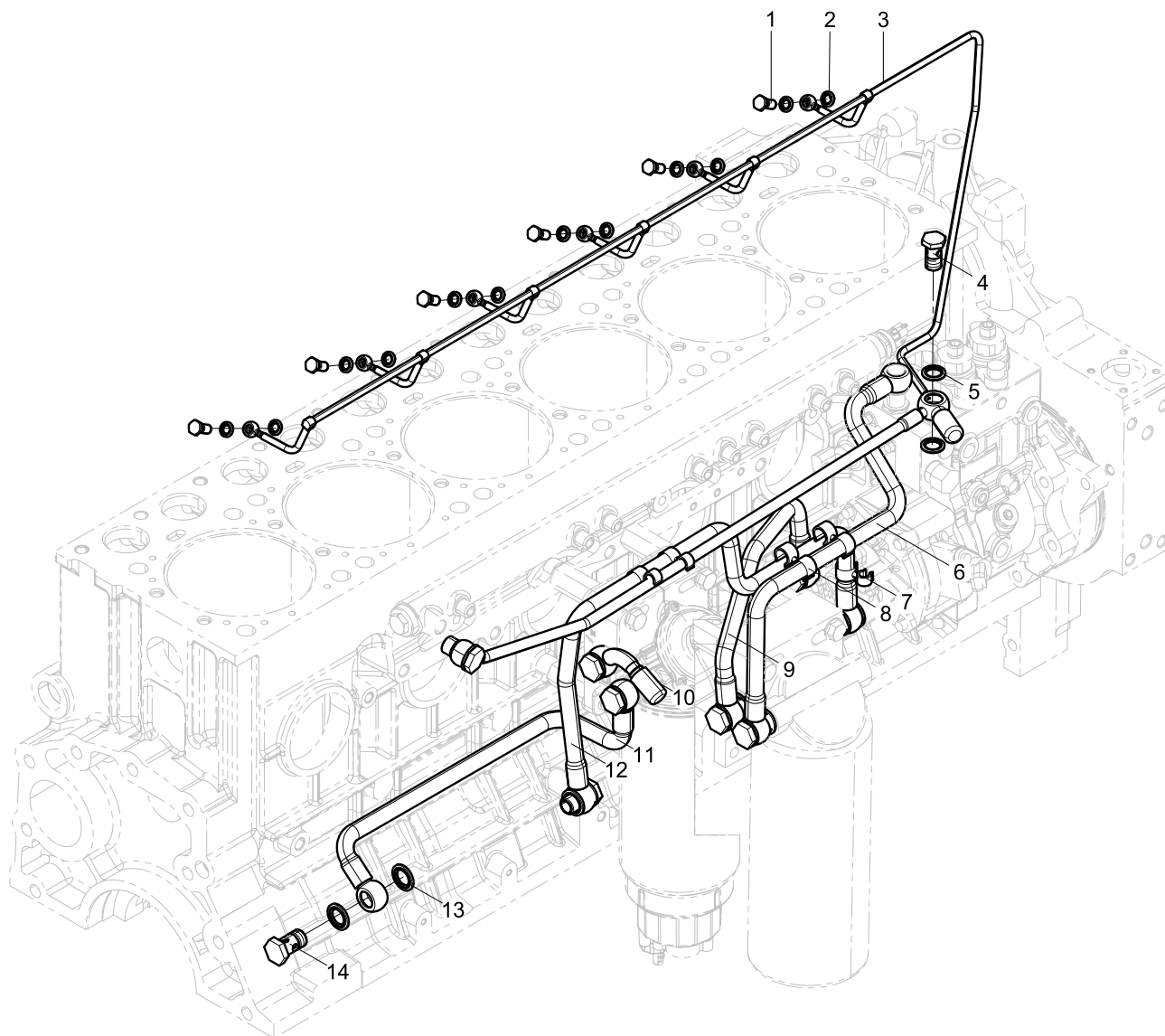

低压油管结合组(Low Pressure Oil pipe Group)

图序号 Pos.	件号 Teile.Number	数量 Amount	中文名称 Denomination	英文名称 Designation
1	90003962603	6	空心螺栓	Hollow bolt
2	612600080201	12	密封垫圈	Seal washer
3	612600080819	1	喷油器回油管总成	Oil return pipe assembly of injector
4	90003962621	1	空心螺栓	Hollow bolt
5	612600080200	2	密封垫圈	Seal washer
6	612600080624	1	燃油管总成	Fuel pipe assembly
7	612600080949	3	管卡	Pipe Clip
8	612600080948	2	管卡	Pipe Clip
9	612600080623	1	燃油管总成	Fuel pipe assembly
10	612600081010	1	管接头	Adapter
11	612600080621	1	燃油管总成	Fuel pipe assembly
12	612600080622	1	燃油管总成	Fuel pipe assembly
13	13023361	18	组合密封垫圈	Unit seal washer
14	612639000049	9	空心螺栓	Hollow bolt

电控线束及传感器结合组(Electronic Control System Harness and Sensor Group)

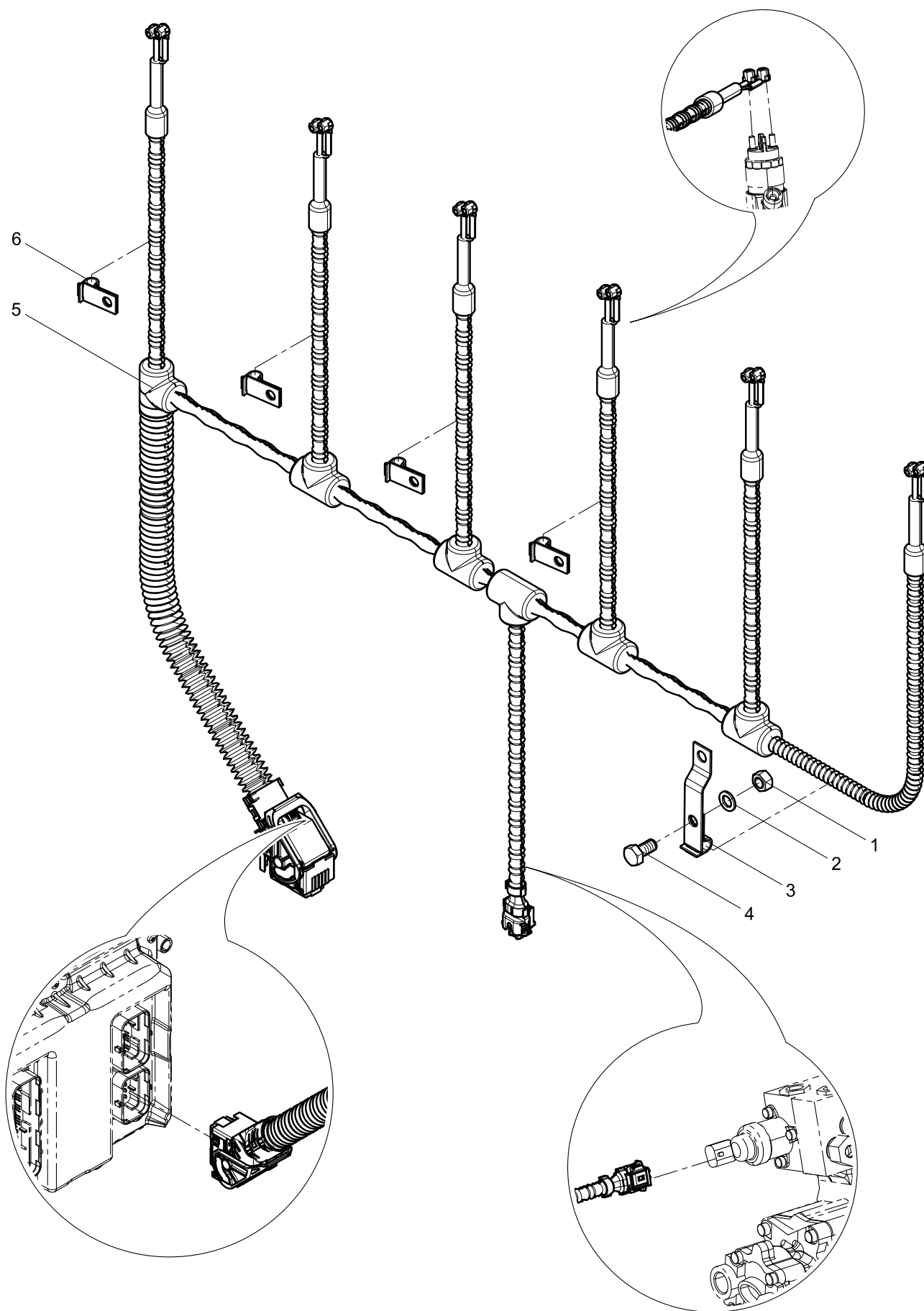

电控线束及传感器结合组(Electronic Control System Harness and Sensor Group)

图序号 Pos.	件号 Teile.Number	数量 Amount	中文名称 Denomination	英文名称 Designation
1	90003871252	1	1型六角螺母	Hexagon nut (I)
2	90003932023	1	波形弹性垫圈	Wave spiral washer
3	612600080834	1	线束固定支架	Harness fixing bracket
4	90003802411	1	六角头螺栓	Hexagon bolt
5	612600090374	1	喷油器线束总成	Wire harness assembly of injector
6	612600080833	4	线束固定支架	Harness fixing bracket

电控线束及传感器结合组(Electronic Control System Harness and Sensor Group)

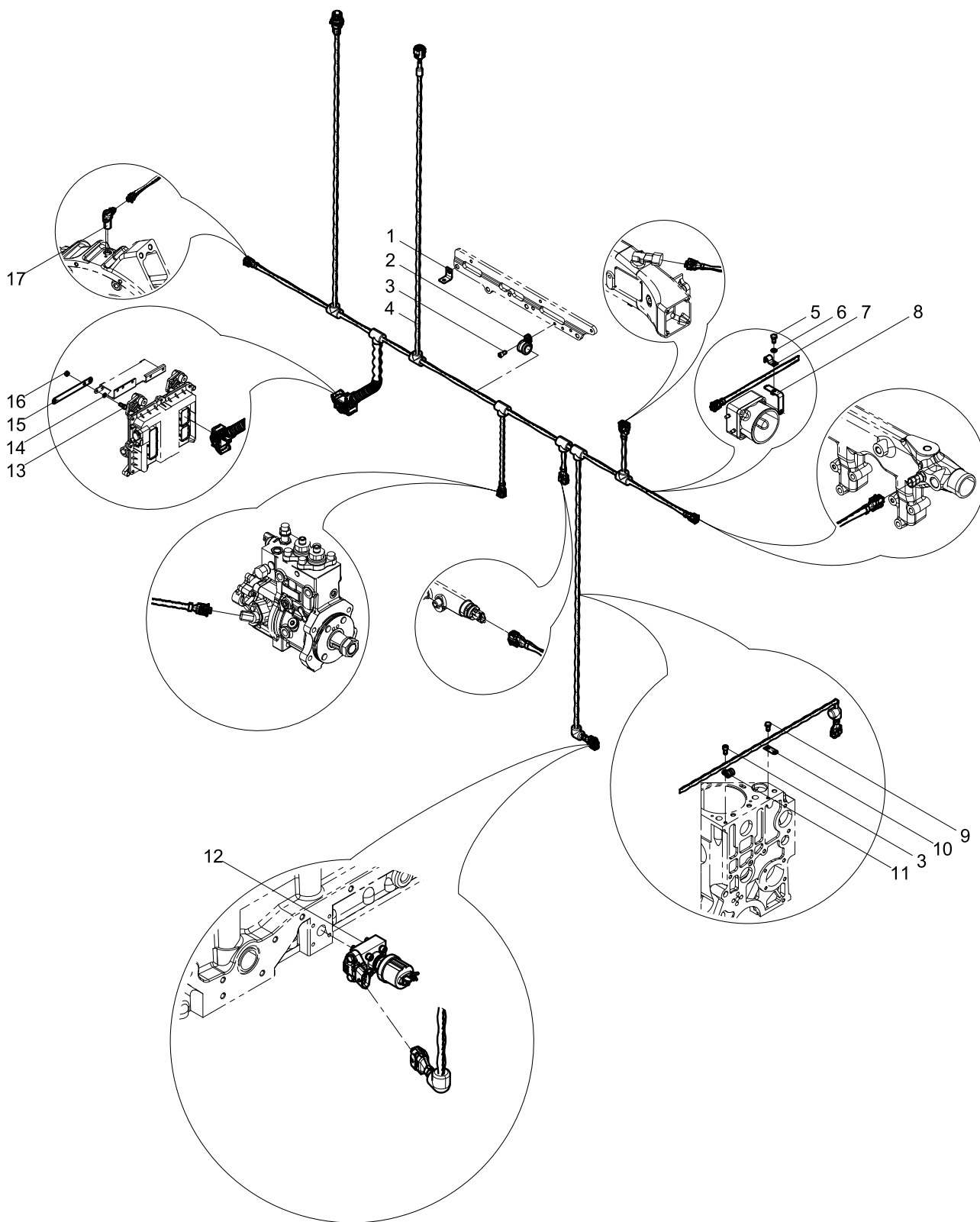

电控线束及传感器结合组(Electronic Control System Harness and Sensor Group)

图序号 Pos.	件号 Teile.Number	数量 Amount	中文名称 Denomination	英文名称 Designation
1	612600081698	1	线束支架	Harness bracket
2	612600081631	1	管夹总成	Pipe Clamp Assembly
3	90003862419	2	内六角圆柱头螺钉	Inner hexagon screw
4	612600080835	1	传感器线束(双油门)	Sensor wiring harness (double throttle)
5	90003802411	1	六角头螺栓	Hexagon bolt
6	90003932023	1	波形弹性垫圈	Wave spiral washer
7	612600082800	1	线束支架	Harness bracket
8	612600082799	1	线束支架	Harness bracket
9	90003802399S	1	六角头螺栓	Hexagon bolt
10	612600080725	1	线束固定板	Harness clamp plate
11	612600081629	1	管夹总成	Pipe Clamp Assembly
12	612600082147	1	机油压力传感器组件	Oil Pressure Sensor Set
13	90003802321	1	六角头螺栓	Hexagon bolt
14	90003932008	1	波形弹性垫圈	Wave spiral washer
15	612600080726	1	线束固定板	Harness clamp plate
16	90003871232	1	1型六角螺母	Hexagon nut (I)
17	612600081751	1	转速传感器组件	

转速传感器组件()

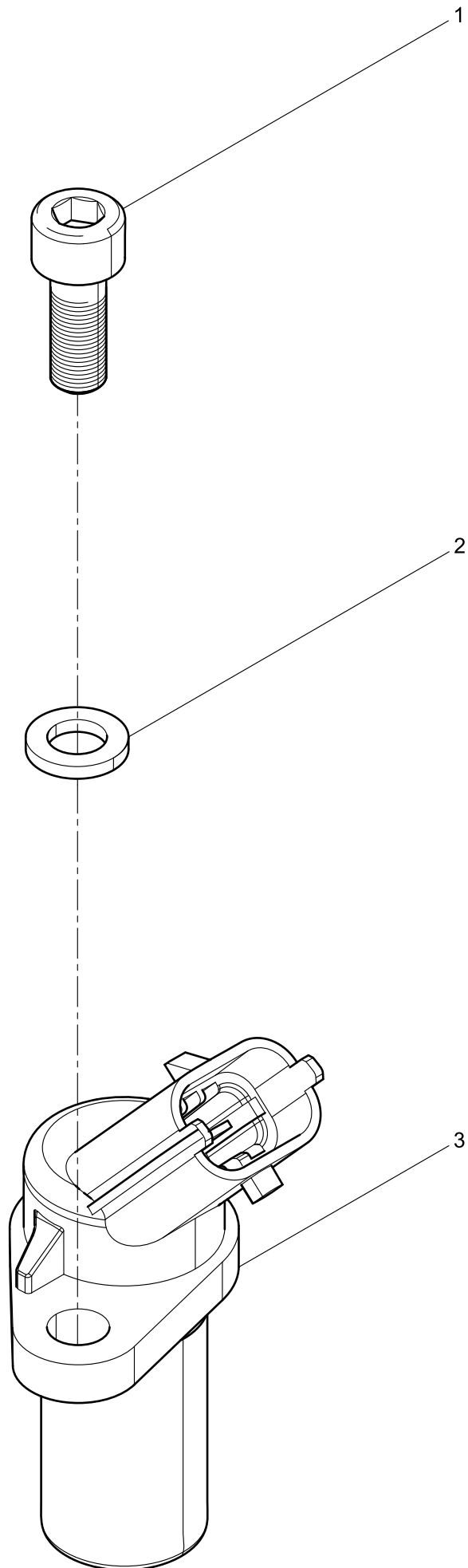

机油压力传感器组件(Oil Pressure Sensor Set)

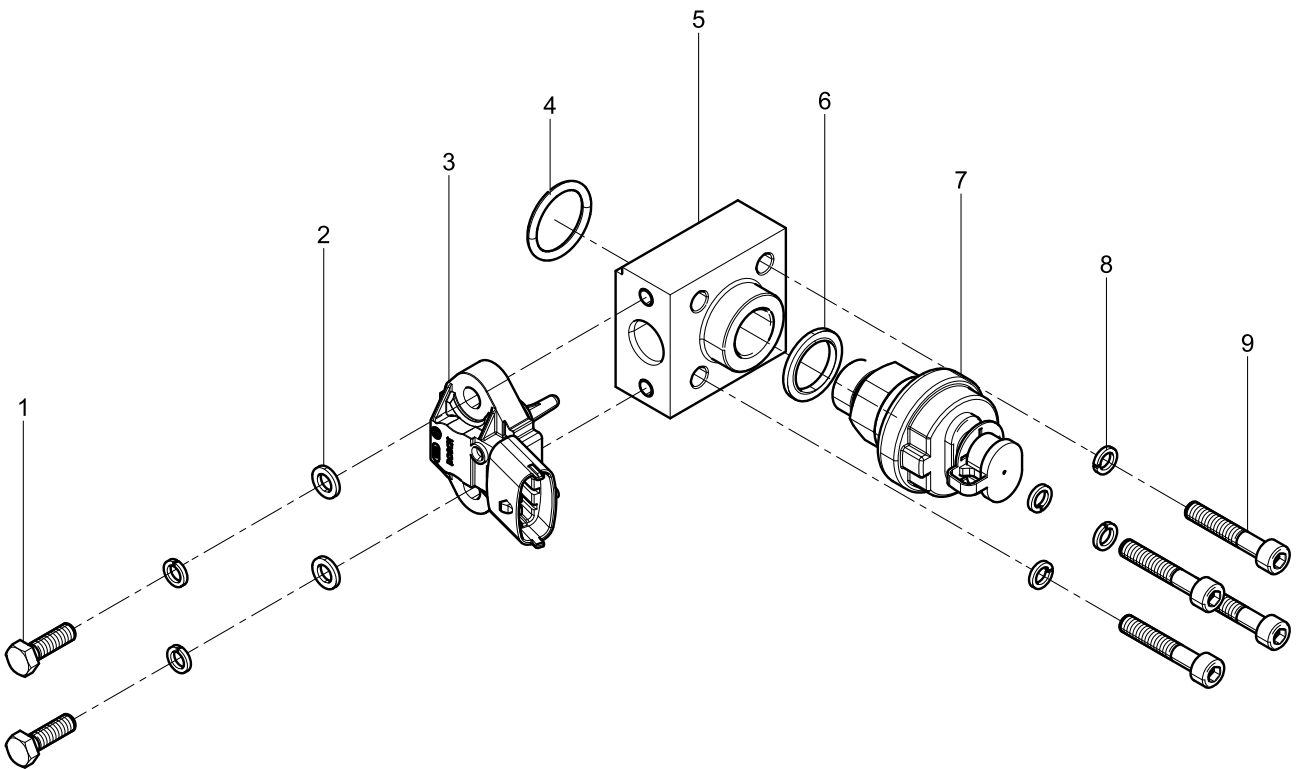

机油压力传感器组件(Oil Pressure Sensor Set)

图序号 Pos.	件号 Teile.Number	数量 Amount	中文名称 Denomination	英文名称 Designation
1	90003802331	2	六角头螺栓	Hexagon bolt
2	90003930251	2	小垫圈	Small washer
3	612600090460	1	压力温度传感器	Pressure and Temperature Sensor
4	612600090367	1	密封圈	Seal washer
5	612600090480	1	传感器座	Sensor seat
6	612600080275	1	密封垫圈	Seal washer
7	612600090667	1	压力传感器	Pressure sensor
8	90014350003	6	弹簧垫圈	Spring washer
9	90013550008	4	内六角圆柱头螺钉	Inner hexagon screw

喷油器结合组(Injector assembly)

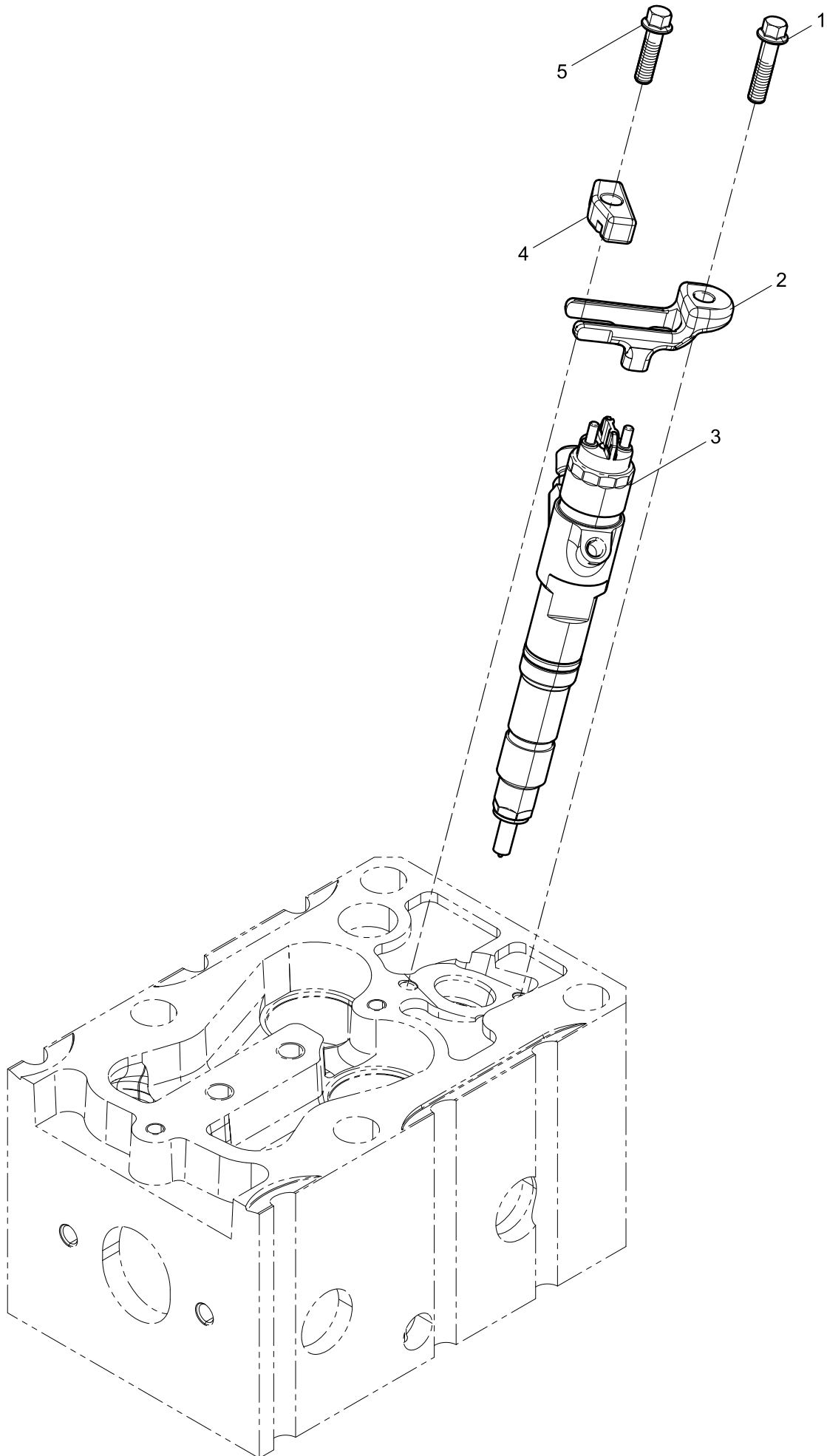

发电机结合组(Generator Group)

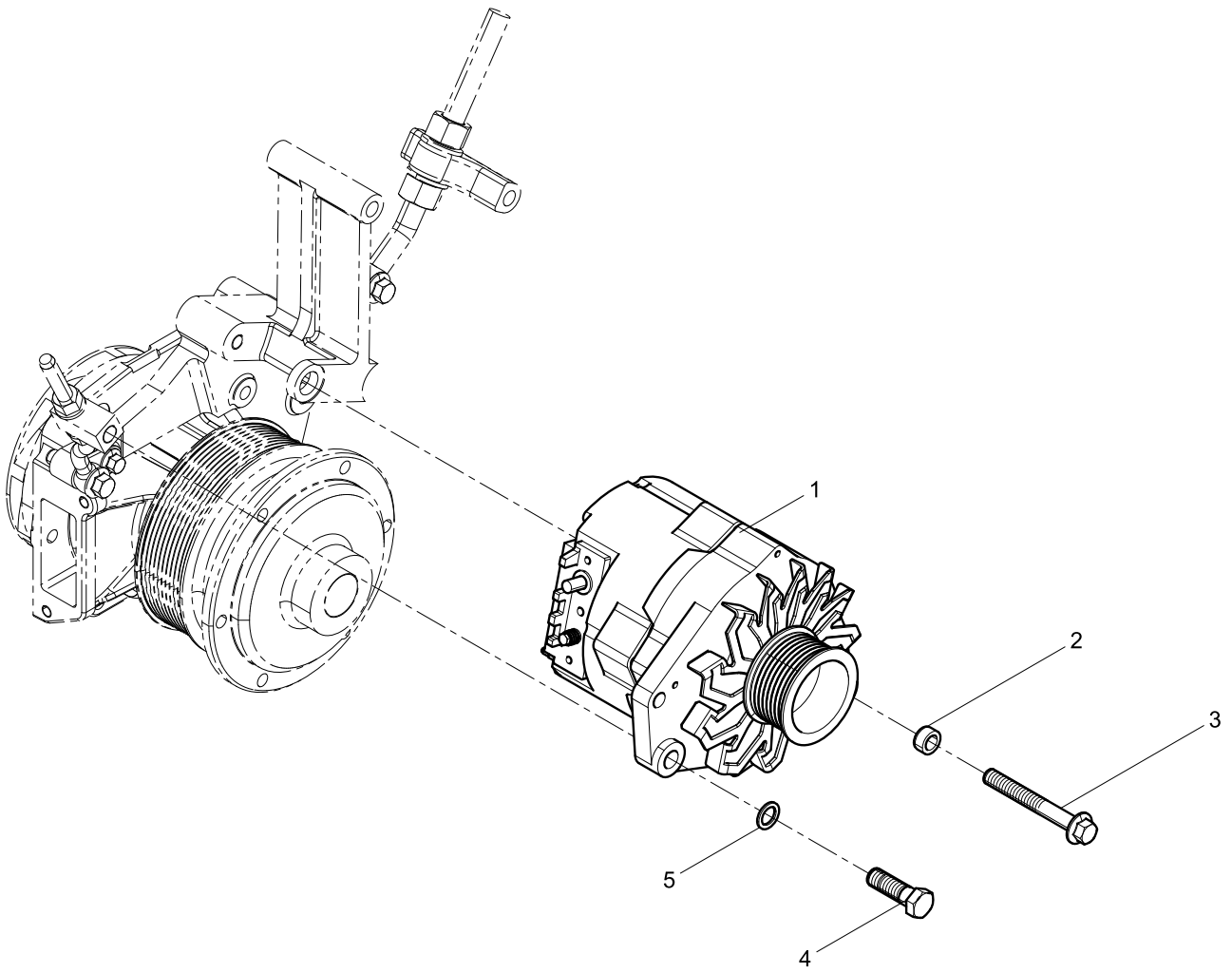

发电机支架结合组(Generator Bracket Group)

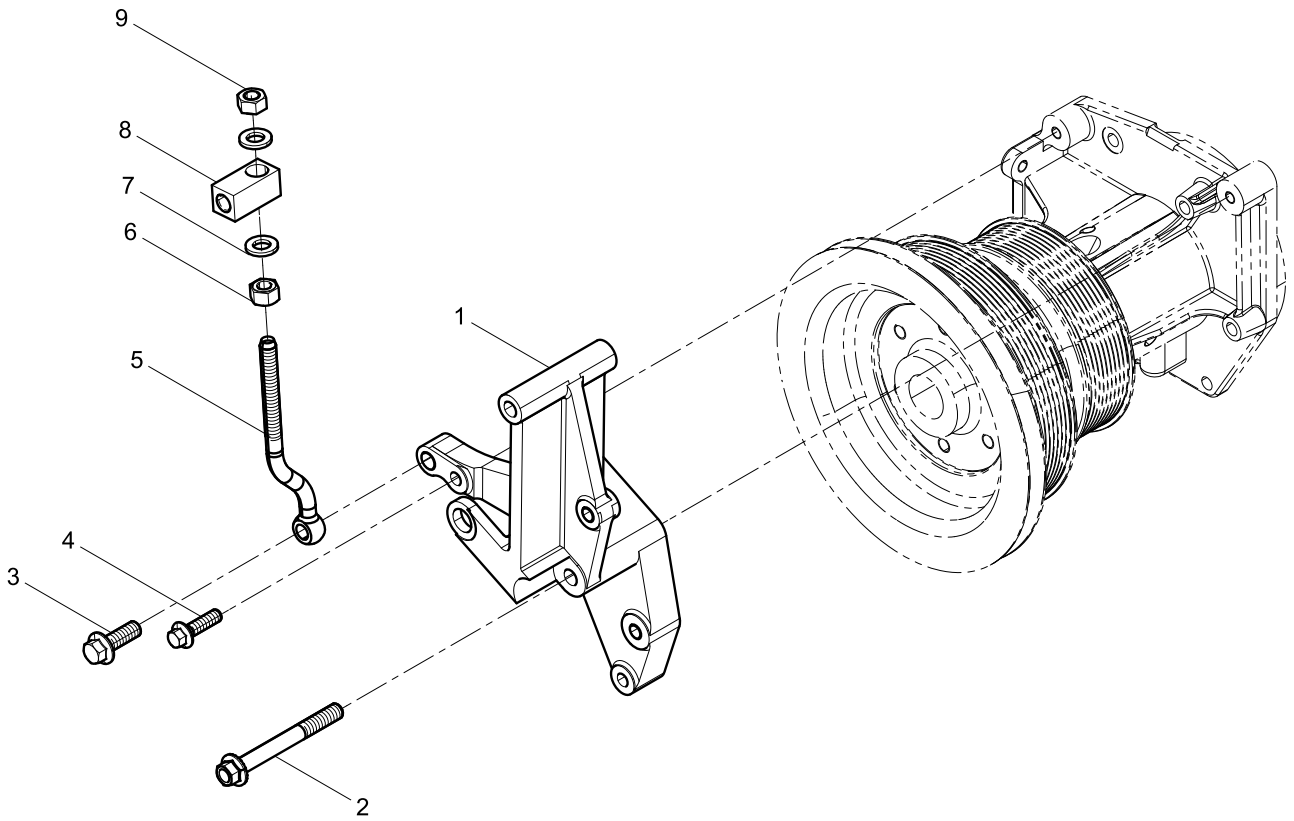

发电机支架结合组(Generator Bracket Group)

图序号 Pos.	件号 Teile.Number	数量 Amount	中文名称 Denomination	英文名称 Designation
1	612600061007	1	托架	Bracket
2	612600061712	1	六角法兰面承面带齿螺栓	Hexagon Flange Bolt
3	90011430012	1	六角法兰面承面带齿螺栓	Hexagon Flange Bolt
4	90011430018	1	六角法兰面承面带齿螺栓	Hexagon Flange Bolt
5	612600090937	1	拉紧螺栓	Tightening bolt
6	90003888452	1	2型全金属六角锁紧螺母	Prevailing Torque Type All-metal Hexagon Nut,
7	90003935125	2	平垫圈	Flat washer
8	612600090094	1	拉紧块	Tightening block
9	90003871305	1	1型六角螺母	Hexagon nut (I)

空调压缩机结合组(Air Conditioning Compressor Group)

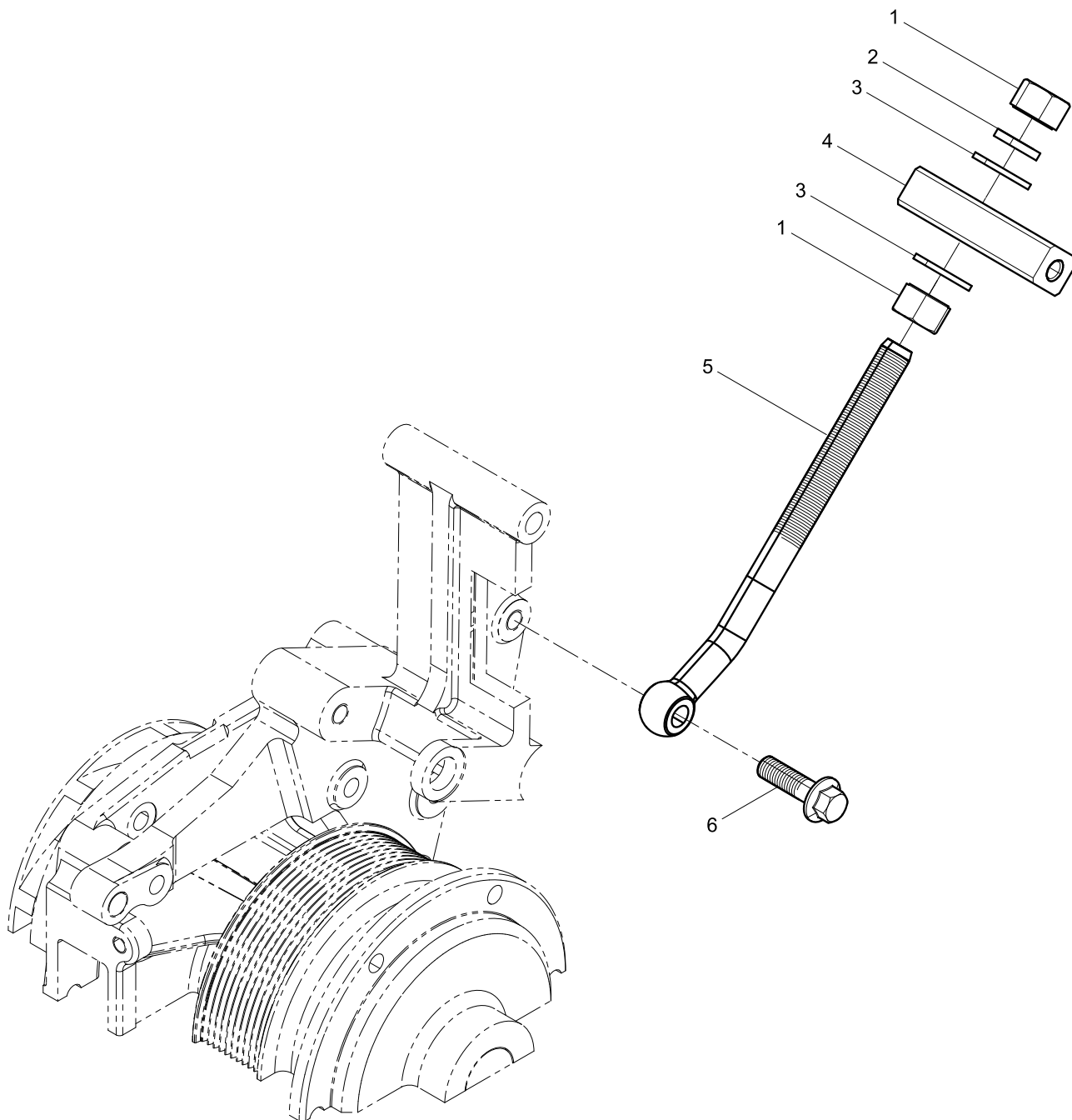

空调压缩机结合组(Air Conditionning Compressor Group)

图序号 Pos.	件号 Teile.Number	数量 Amount	中文名称 Denomination	英文名称 Designation
1	90012630006	2	1型六角螺母	Hexagon nut (I)
2	90014010003	1	标准型弹簧垫圈	Single Coil Spring Lock Washer, Normal Type
3	90003935015	2	平垫圈	Flat washer
4	612600130468	1	间隔块	Spacer block
5	612600061008	1	拉紧螺栓	Tightening bolt
6	90011430009	1	六角法兰面承面带齿螺栓	Hexagon Flange Bolt

起动机结合组(Starter Motor Group)

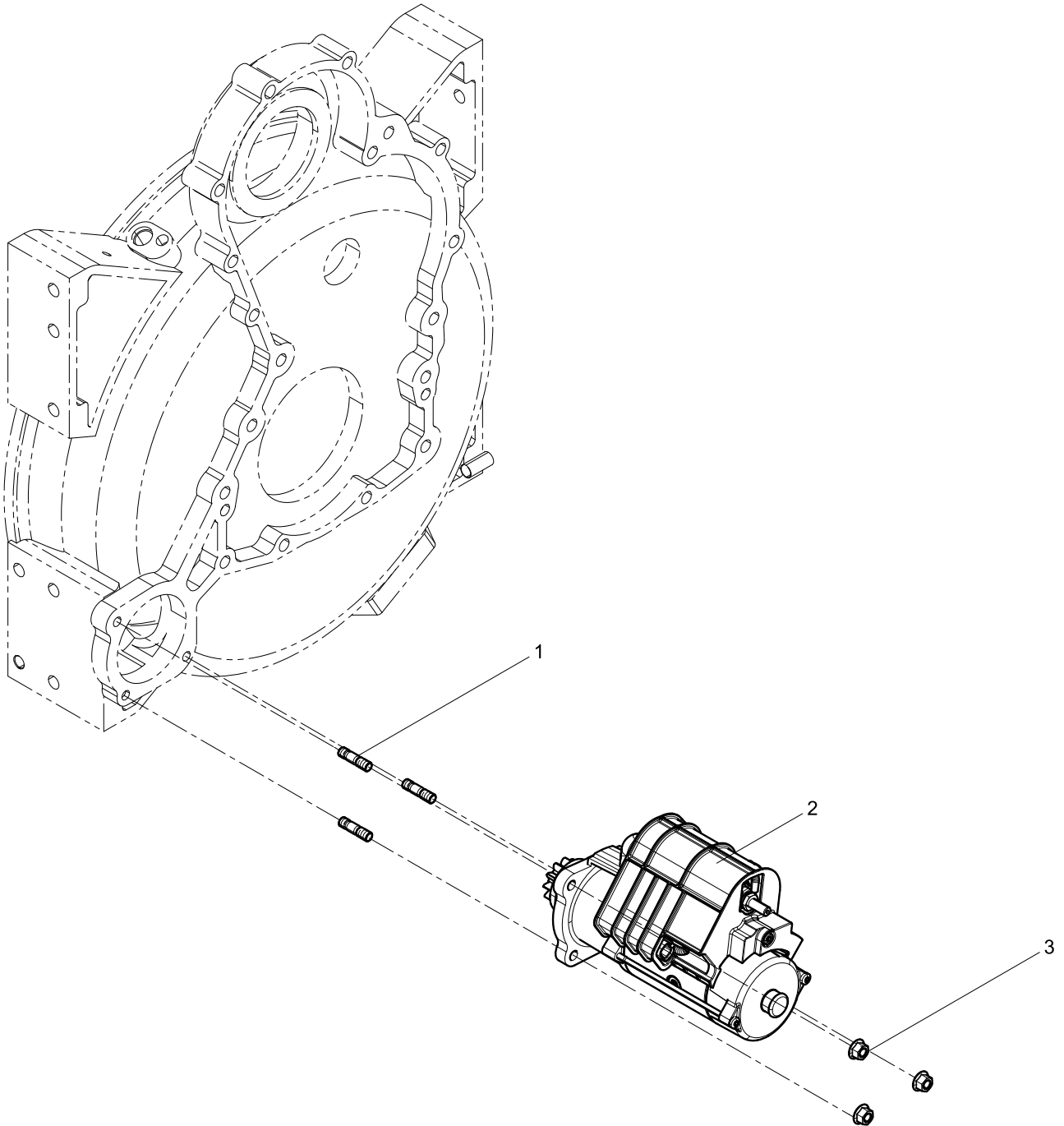

起动机结合组(Starter Motor Group)

图序号 Pos.	件号 Teile.Number	数量 Amount	中文名称 Denomination	英文名称 Designation
1	90003813527	3	双头螺柱	Stud
2	612600090562	1	起动机	Starter
3	612600013602	3	六角法兰面螺母	Hexagon Flange Nut

进气管结合组(Intake Manifold Group)

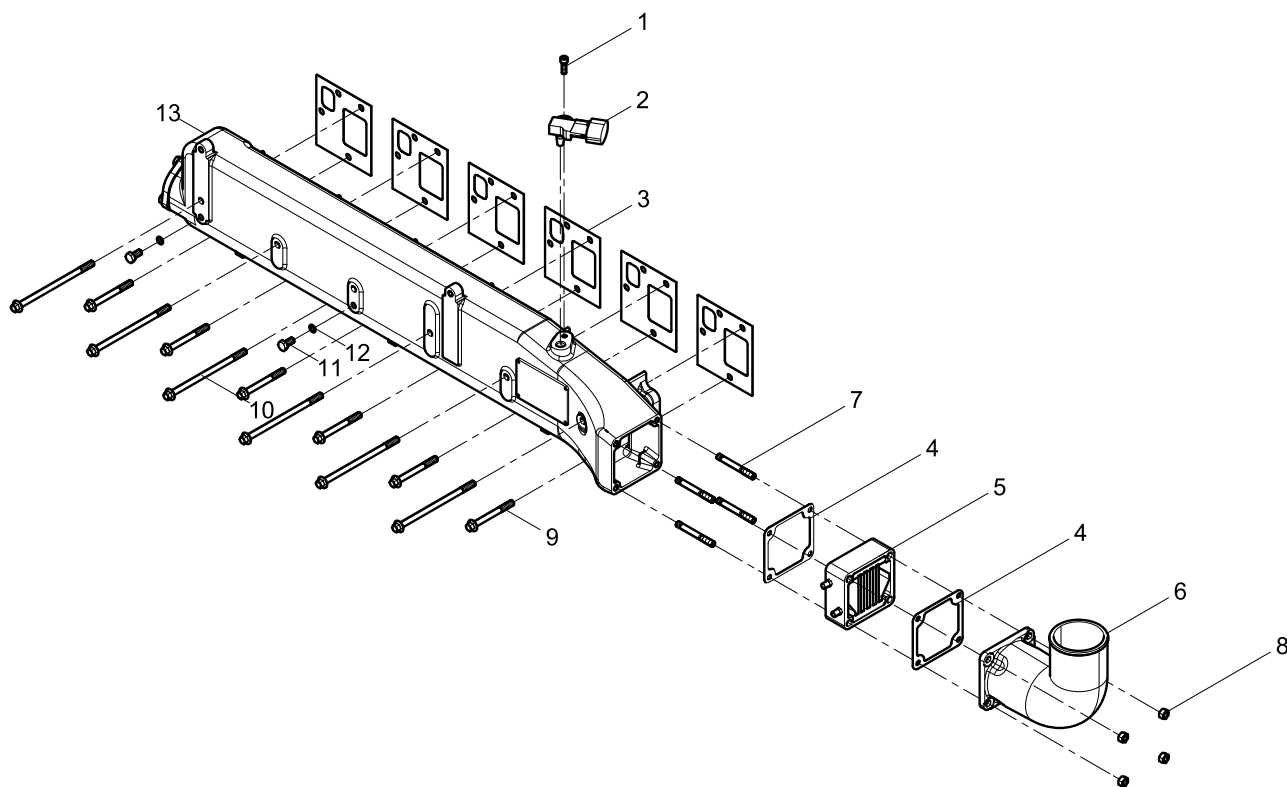

进气管结合组(Intake Manifold Group)

图序号 Pos.	件号 Teile.Number	数量 Amount	中文名称 Denomination	英文名称 Designation
1	90013550009	1	内六角圆柱头螺钉	Inner hexagon screw
2	612630120004	1	压力温度传感器	Pressure and Temperature Sensor
3	61500110024	6	进气管垫片	Air inlet pipe gasket
4	612630120002	2	垫片	Gasket
5	612630120003	1	加热器	Heater
6	612600111911	1	进气接管	Air intake joint pipe
7	90003813470	4	双头螺柱	Stud
8	90012290001	4	六角法兰面螺母	Hexagon Flange Nut
9	612600114858	6	六角法兰面螺栓	Hexagon Flange Bolt
10	612600114467	6	六角法兰面螺栓	Hexagon Flange Bolt
11	90003802411	2	六角头螺栓	Hexagon bolt
12	90003098008	2	密封垫圈	Seal washer
13	612600111766	1	进气管总成	Air inlet pipe assembly

进气管总成(Air inlet pipe assembly)

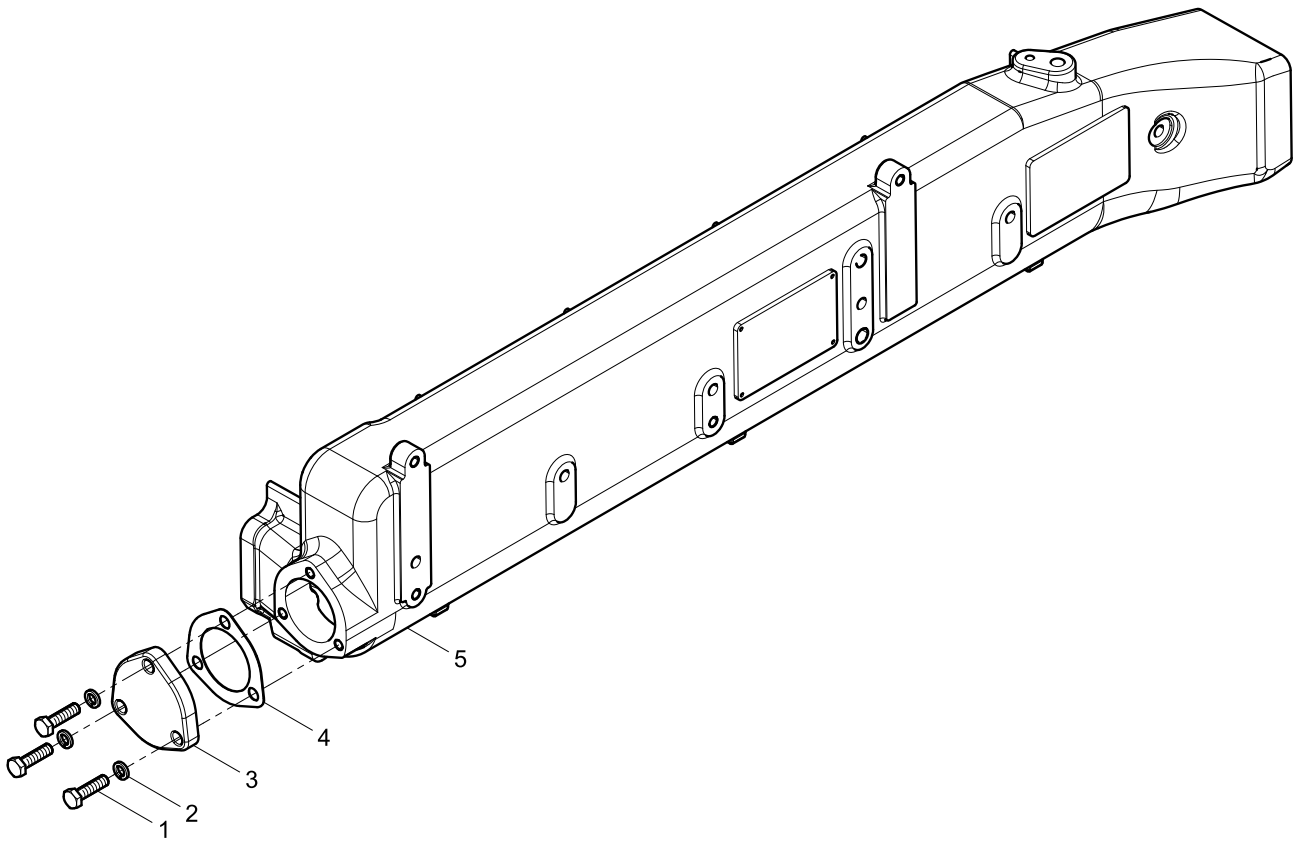

排气管结合组(Exhaust Manifold Group)

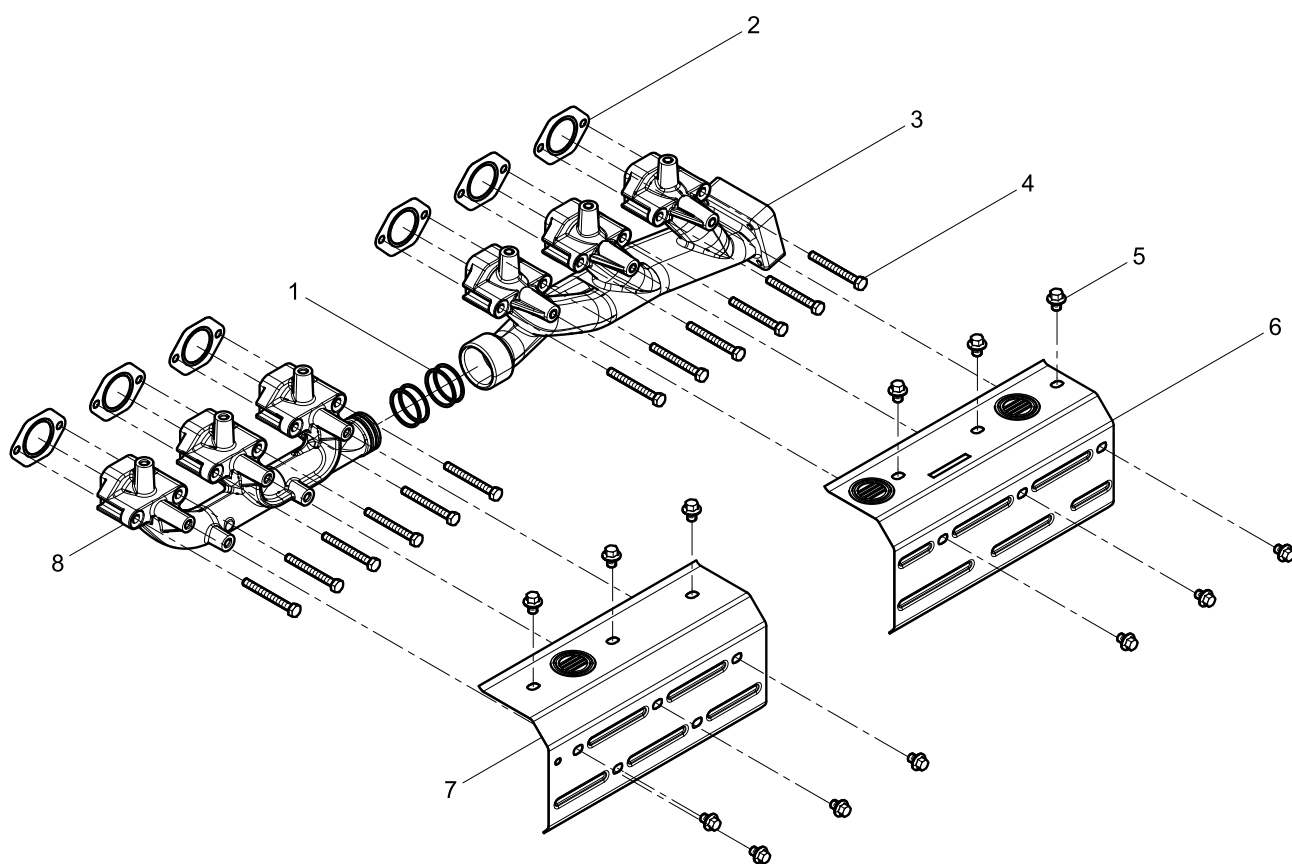

排气管结合组(Exhaust Manifold Group)

图序号 Pos.	件号 Teile.Number	数量 Amount	中文名称 Denomination	英文名称 Designation
1	61260110162	4	排气管密封环	Seal washer of exhaust pipe
2	61560110242	6	排气管垫片	Exhaust pipe gasket
3	612600111280	1	后排气歧管	Rear exhaust manifold
4	61560110104	12	排气管紧固螺拴	Tightening bolt of exhaust pipe
5	612600115839	1	六角法兰面承面带齿螺栓	Hexagon Flange Bolt
6	612600113841	1	排气管隔热罩	Heat insulating cover of exhaust pipe
7	612600113842	1	排气管隔热罩	Heat insulating cover of exhaust pipe
8	612600114609	1	前排气歧管	Front exhaust manifold

增压器结合组(Turbocharger assembly)

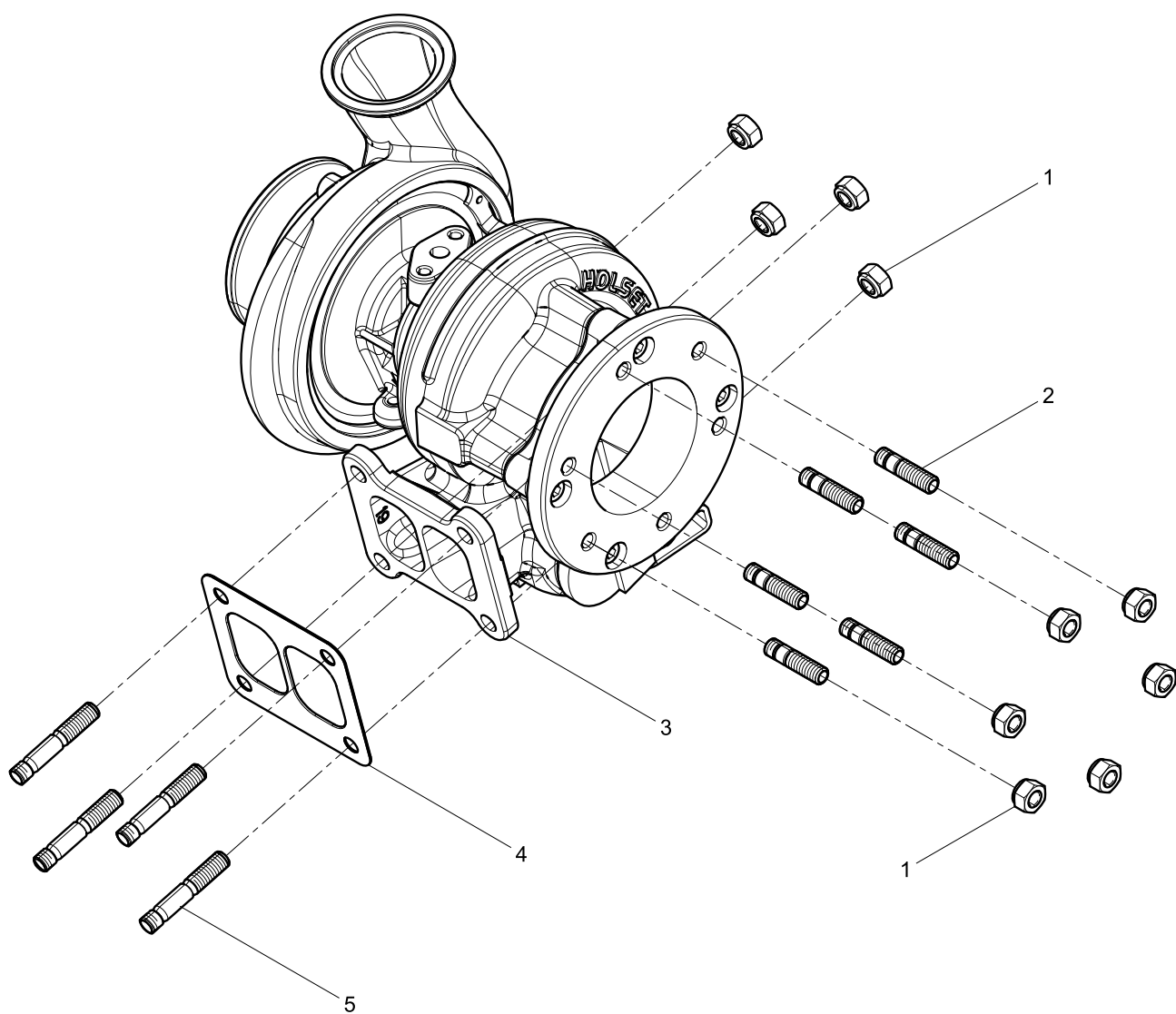

增压器结合组(Turbocharger assembly)

图序号 Pos.	件号 Teile.Number	数量 Amount	中文名称 Denomination	英文名称 Designation
1	90003888470	10	2型全金属六角锁紧螺母	Prevailing Torque Type All-metal Hexagon Nut,
2	81560110187	6	双头螺柱	Stud
3	612600118895	1	HX50增压器	HX50 turbocharger
4	612600111113	1	增压器垫片	Turbocharger washer
5	612600111745	4	双头螺柱	Stud

增压器润滑油管结合组(Turbocharger Oil pipe Group)

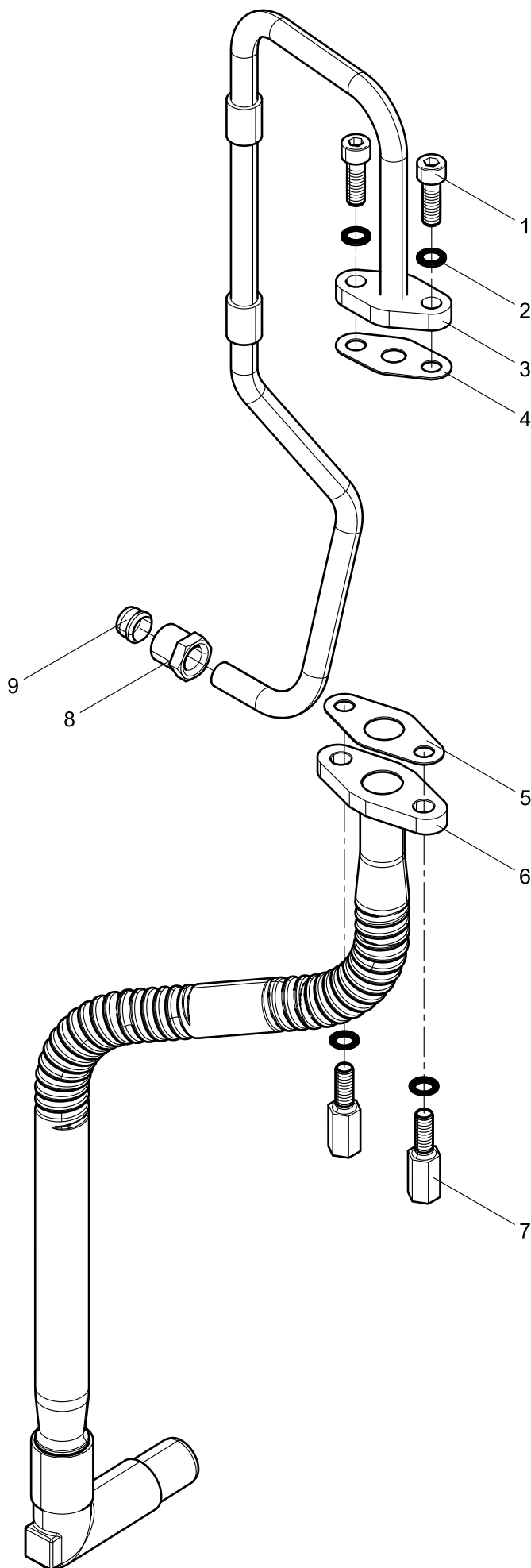

压气机管路结合组(Compressor Pipeline Group)

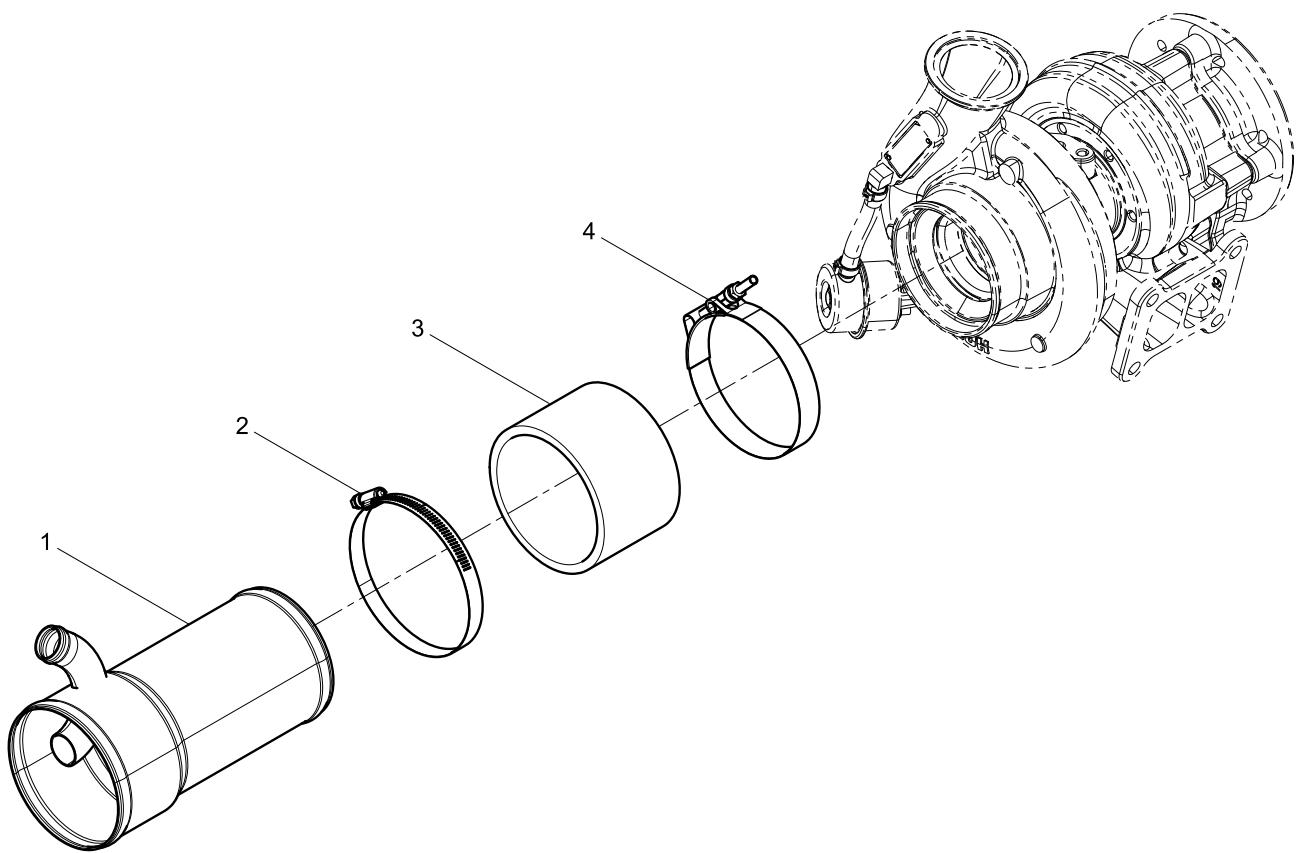

中冷器结合组(Intercooler assembly)

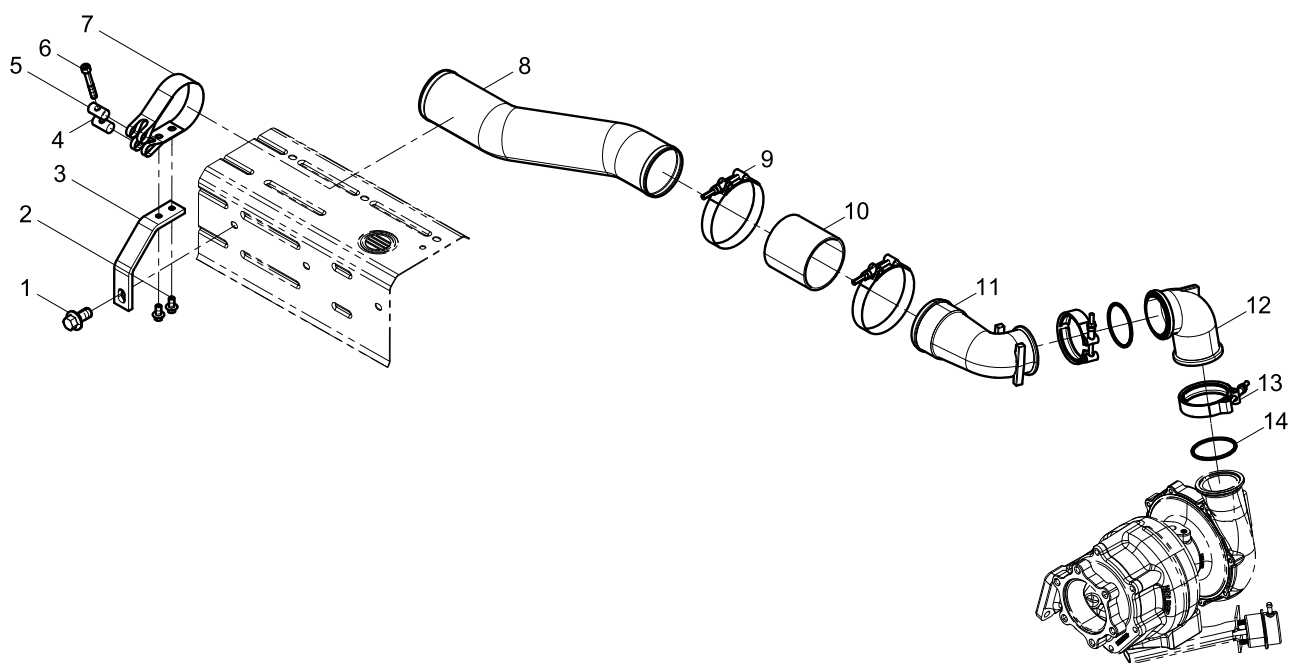

中冷器结合组(Intercooler assembly)

图序号 Pos.	件号 Teile.Number	数量 Amount	中文名称 Denomination	英文名称 Designation
1	612600115145	1	六角法兰面承面带齿螺栓	Hexagon Flange Bolt
2	90011430040	2	六角法兰面承面带齿螺栓	Hexagon Flange Bolt
3	612600111590	1	支架	Bracket
4	1700550013	1	张紧销	Tension pin
5	209190017	1	拉紧销	Pin
6	90003862462	1	内六角圆柱头螺钉	Inner hexagon screw
7	612600110317	1	卡箍带	Clamp
8	612600111892	1	中冷器进气管	Air intake pipe of intercooler
9	612600112232	2	卡箍	Clamp
10	612600111086	1	气路连接胶管	Air Connecting Rubber Pipe
11	612600110365	1	接管	Adapter
12	612600110364	1	中冷器进气弯管	Intake elbow
13	61560110226	2	卡箍	Clamp
14	190320035	2	密封圈	Seal washer

空压机结合组(Air Compressor Group)

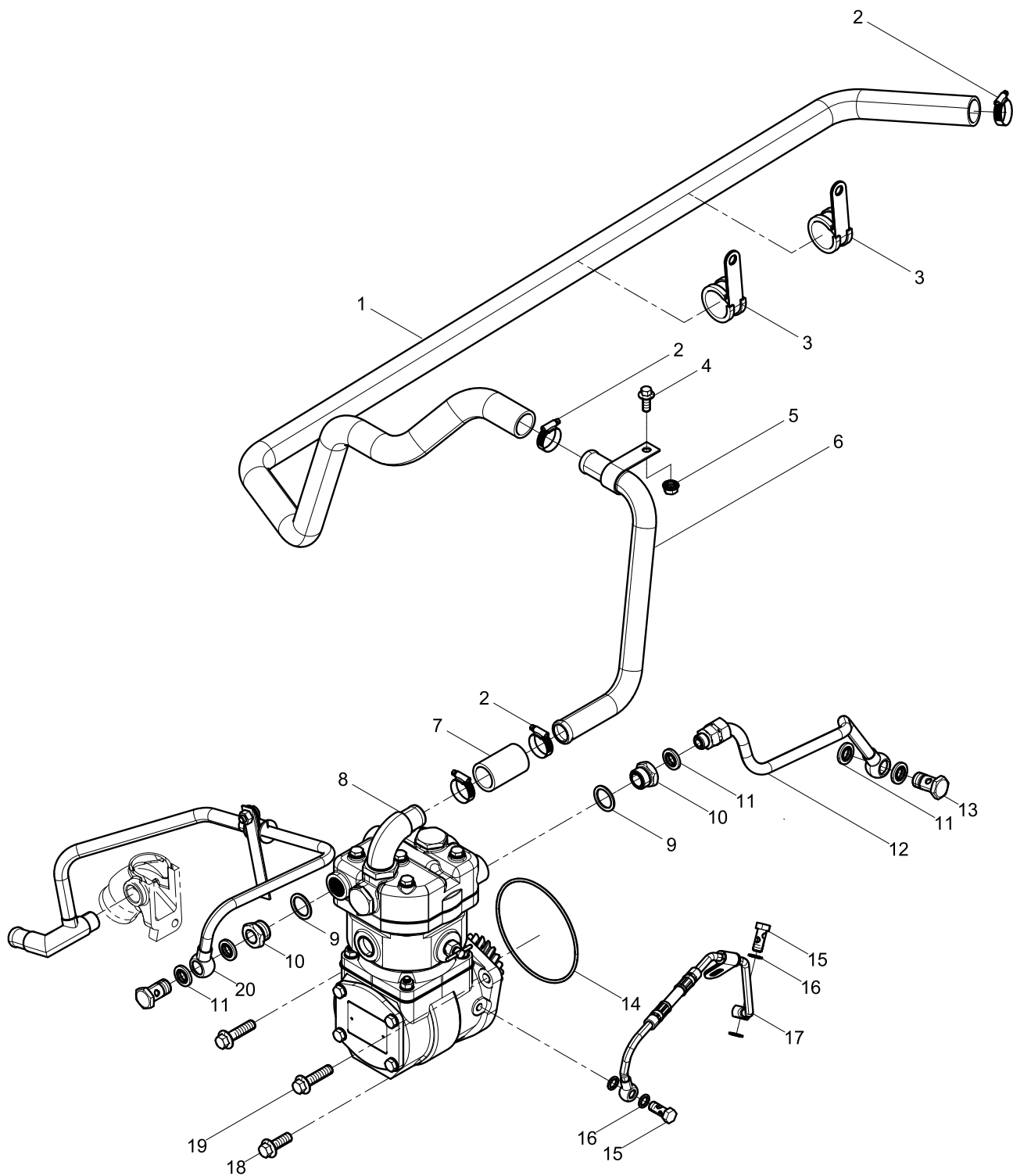

空压机结合组(Air Compressor Group)

图序号 Pos.	件号 Teile.Number	数量 Amount	中文名称 Denomination	英文名称 Designation
1	612600130653	1	空压机进气管	Air inlet pipe of air compressor
2	90003989301	4	软管卡箍	Hose clip
3	612600112639	2	管夹总成	Pipe Clamp Assembly
4	90011430016	1	六角法兰承面带齿螺栓	Toothed bolt
5	612600061719	1	六角法兰面承面带齿螺母	Hexagon Flange Nut
6	612600130363	1	空压机进气管	Air inlet pipe of air compressor
7	612630060017	1	油路连接胶管	Oil Connecting Rubber Pipe
8	612600130927	1	空压机总成	Air compressor assembly
9	13023364	2	组合密封垫圈	Unit seal washer
10	99100360161	2	接头体	Adapter body
11	13023361	5	组合密封垫圈	Unit seal washer
12	612600130316	1	空压机进水管	Water inlet pipe of air compressor
13	90003962627	2	空心螺栓	Hollow bolt
14	30800010003	1	密封圈	Seal washer
15	612600130333	2	空心螺栓	Hollow bolt
16	612600080246	4	密封垫圈	Seal washer
17	612600130326	1	空压机润滑油管总成	Oil pipe of air compressor assembly
18	90011430017S	1	六角法兰面承面带齿螺栓	Hexagon Flange Bolt
19	90011430032	2	六角法兰面承面带齿螺栓	Hexagon Flange Bolt
20	612600130355	1	空压机回水管总成	Water return pipe assembly of air compressor

空压机总成(Air compressor assembly)

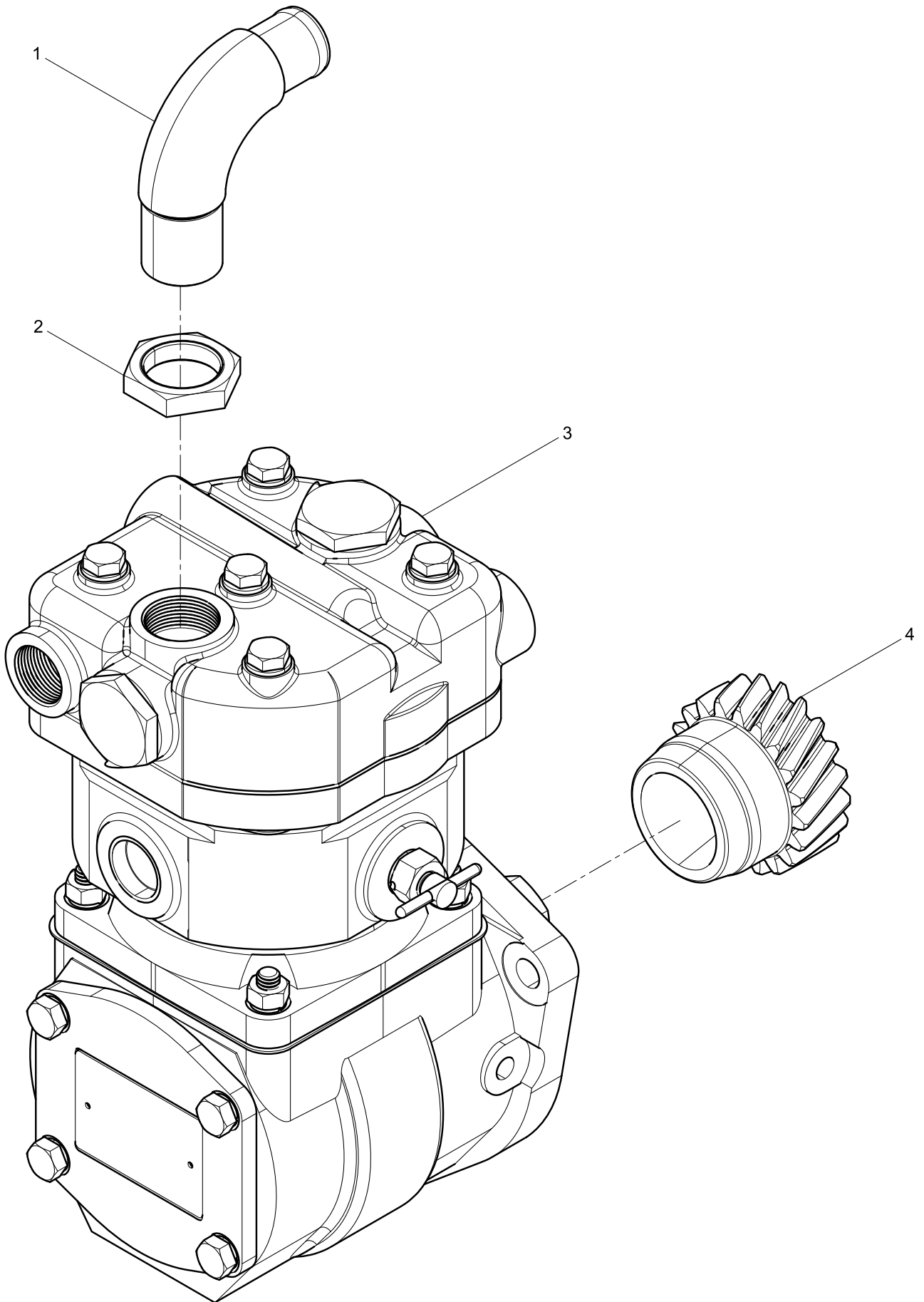

液压泵结合组(Hydraulic Pump Group)

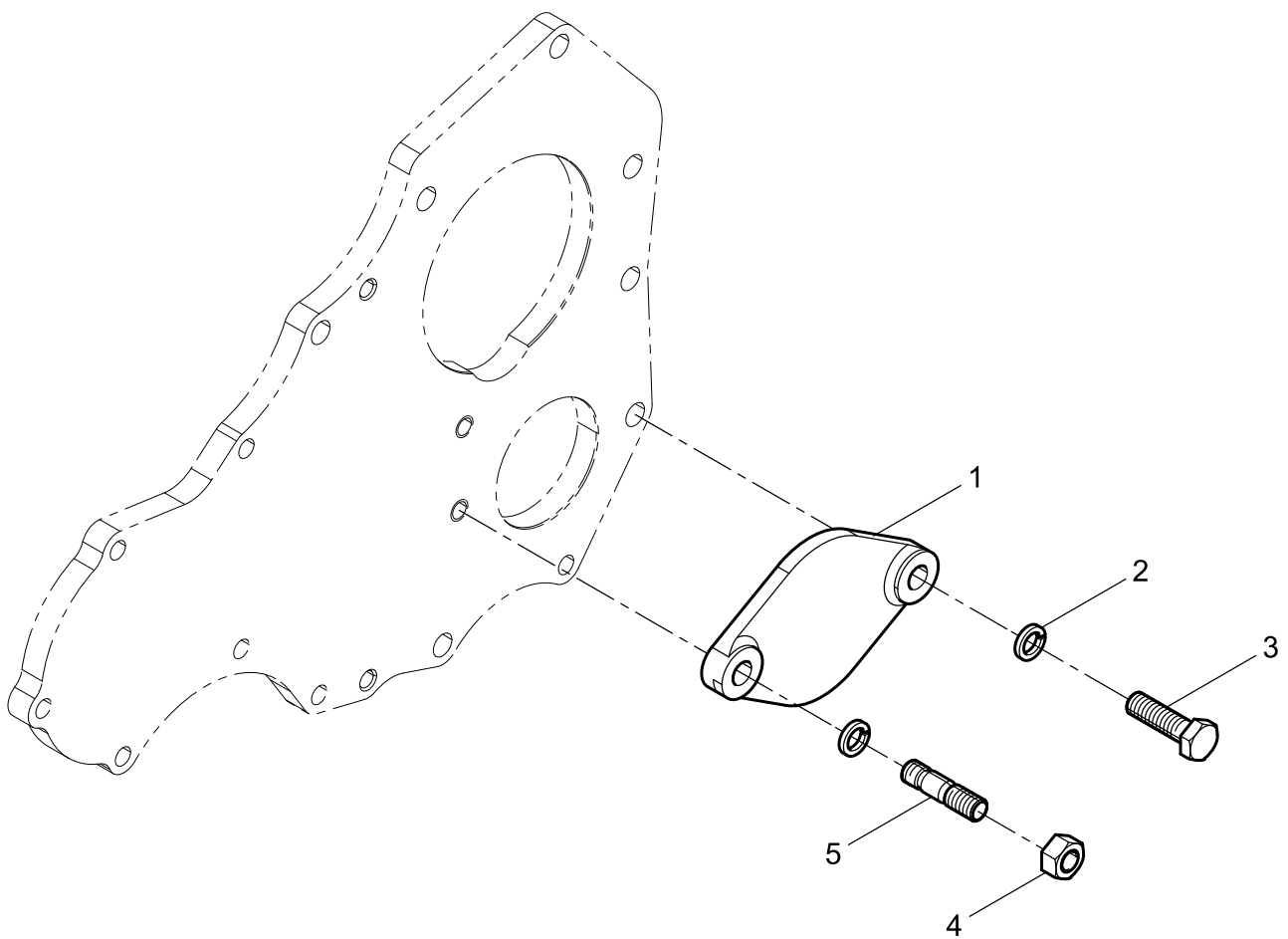

油底壳结合组(Oil Pan Group)

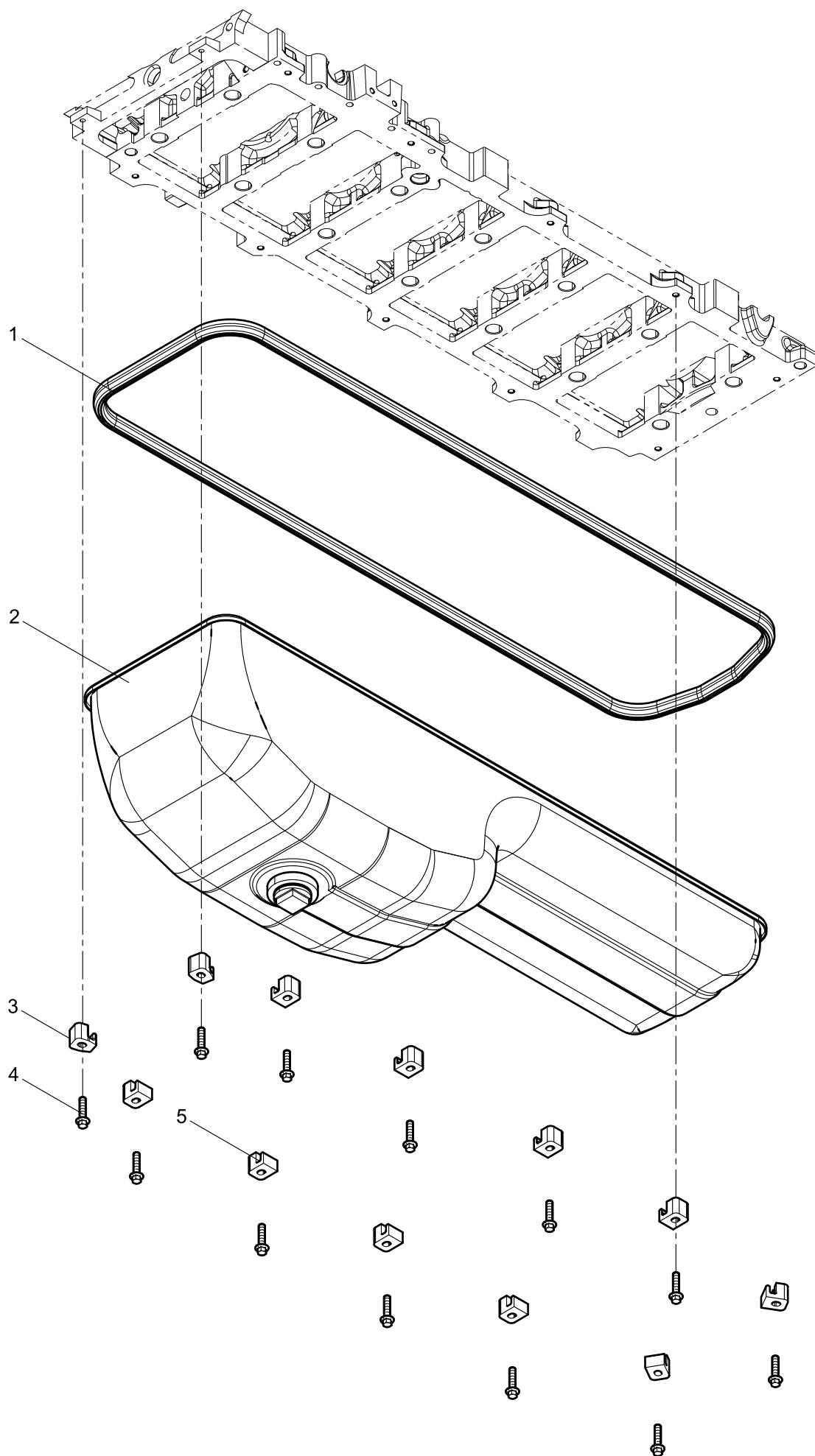

油底壳总成(Oil pan assembly)

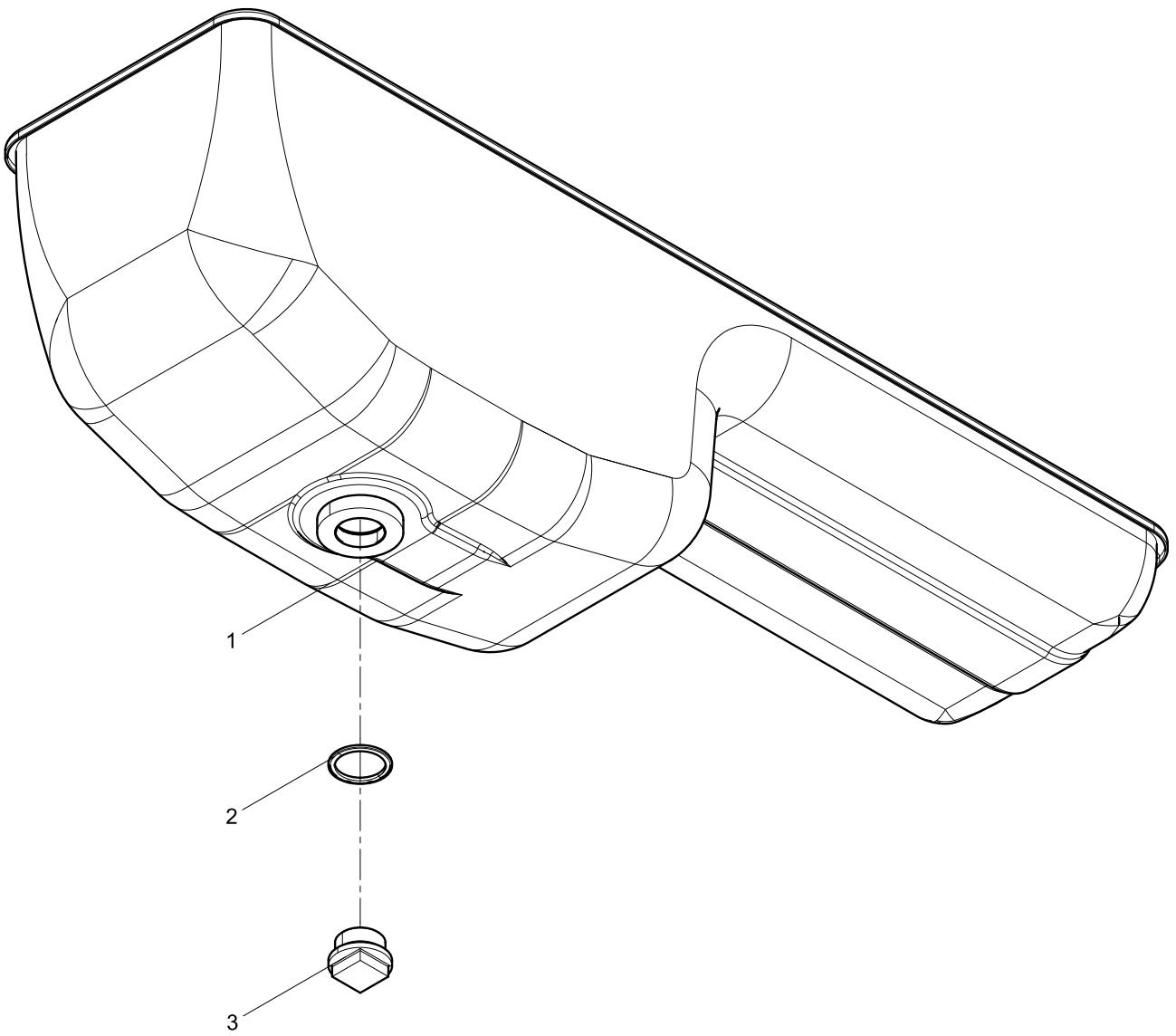

发动机支架结合组(Engine Bracket Group)

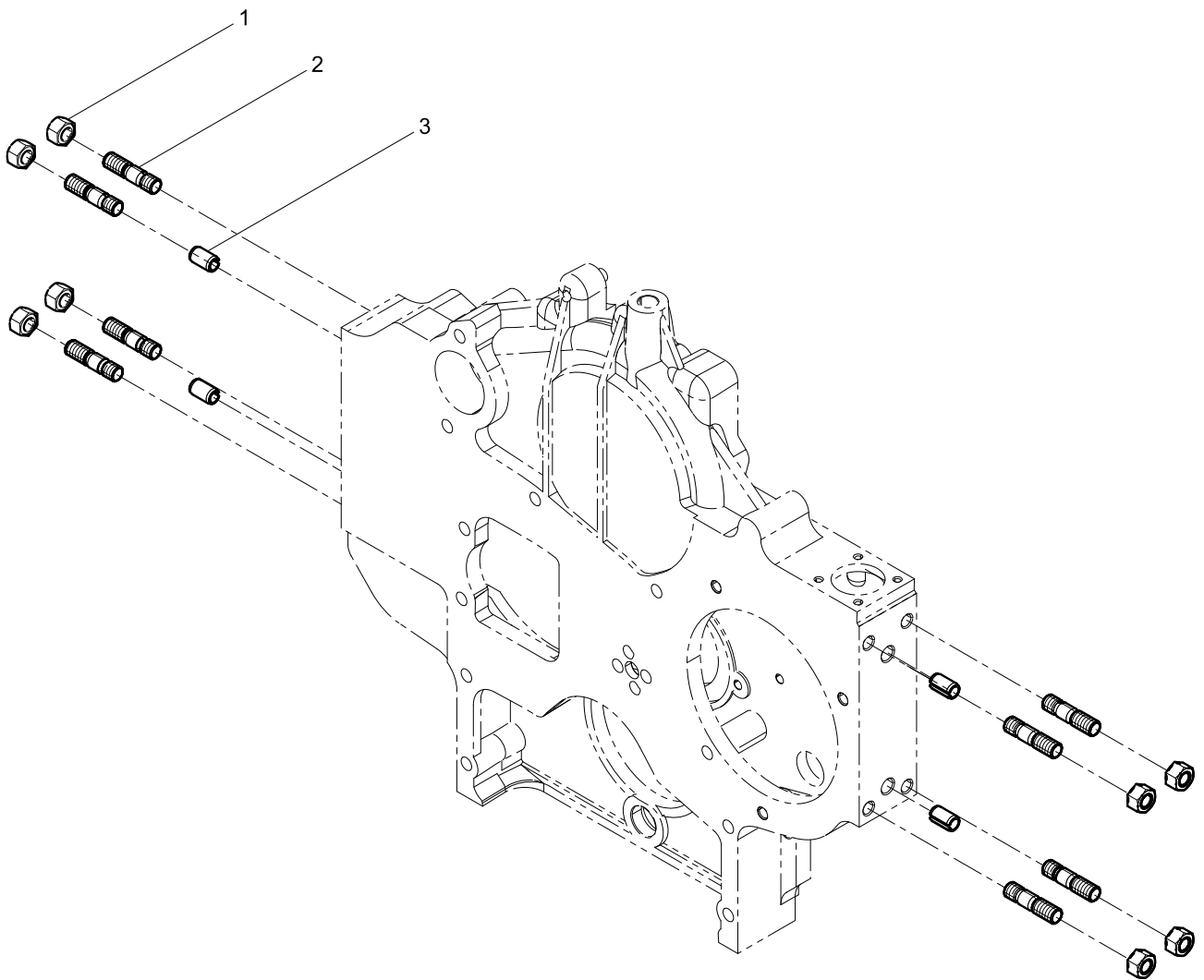

直送零件结合组()

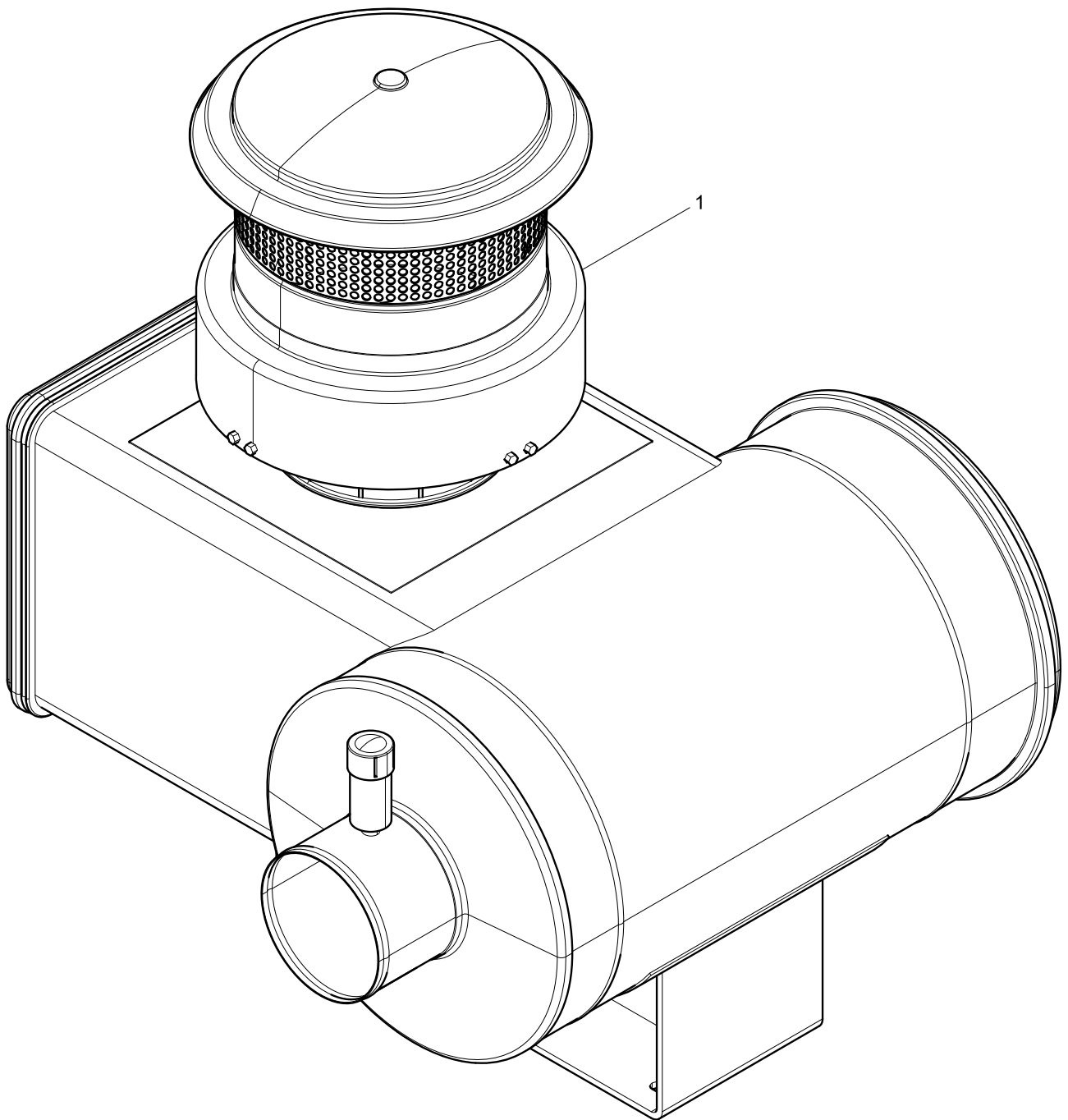

WP多级复合沙尘滤()

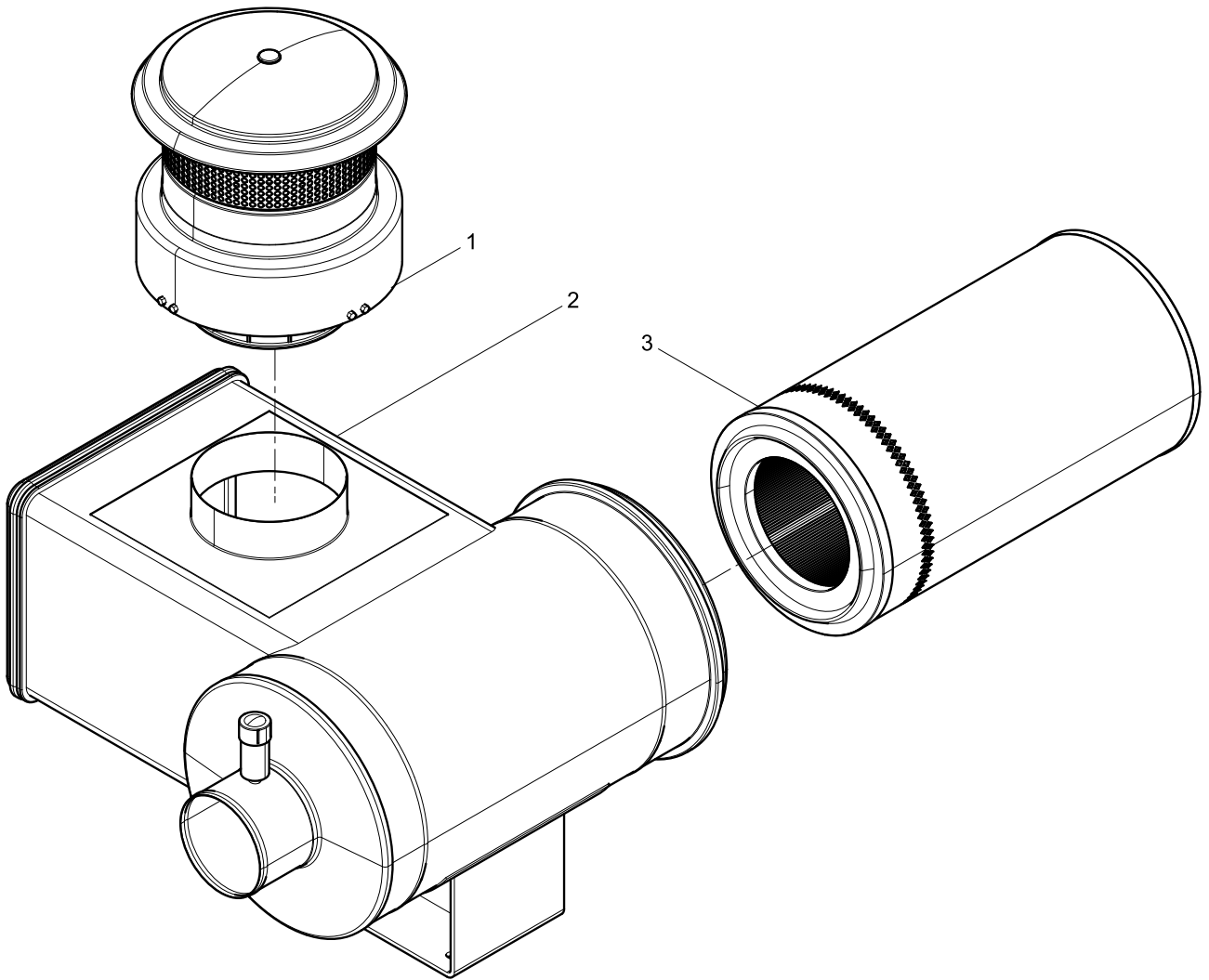

零件箱总成(Parts Kit Assembly)

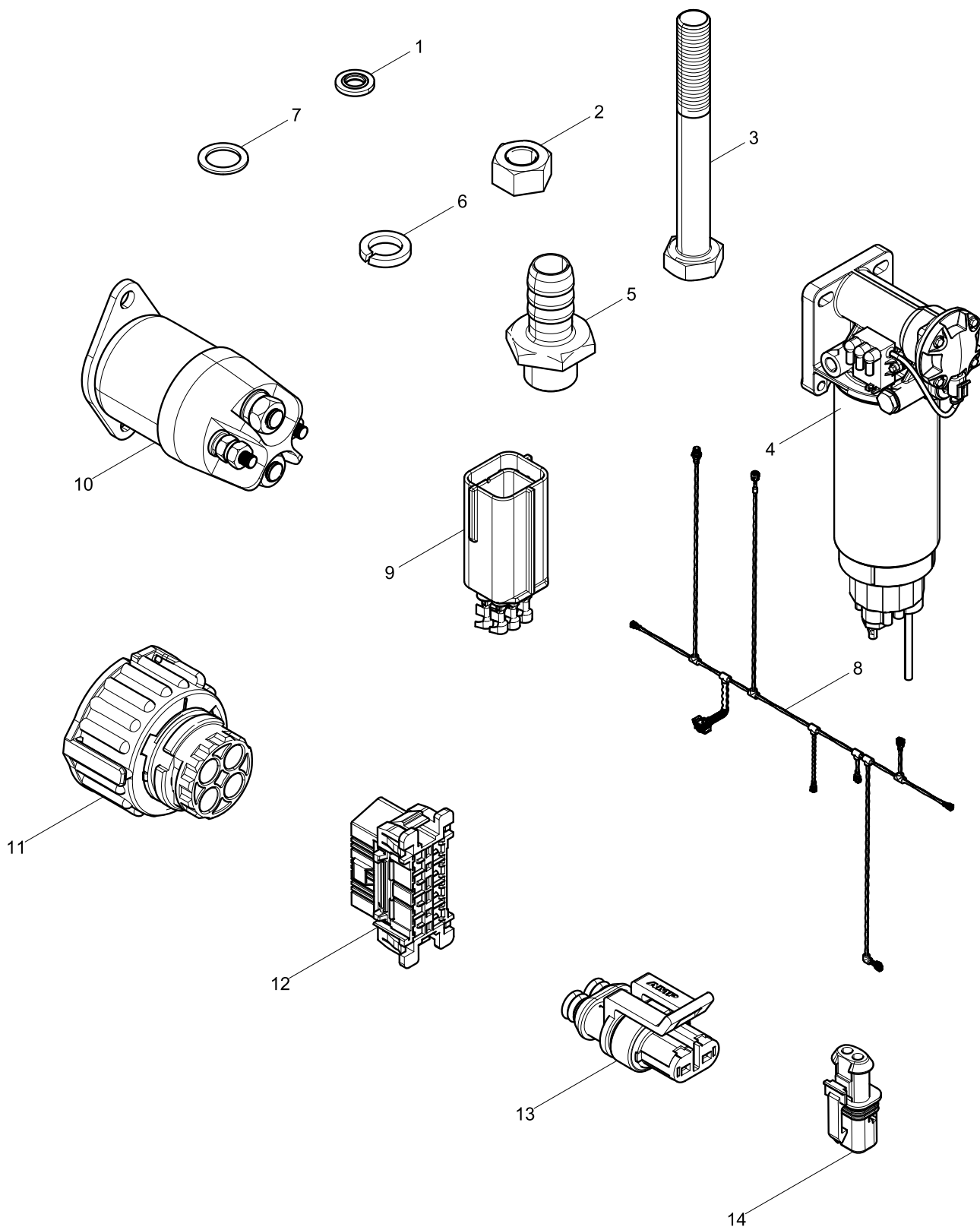

16孔诊断接口插接件(方形)()

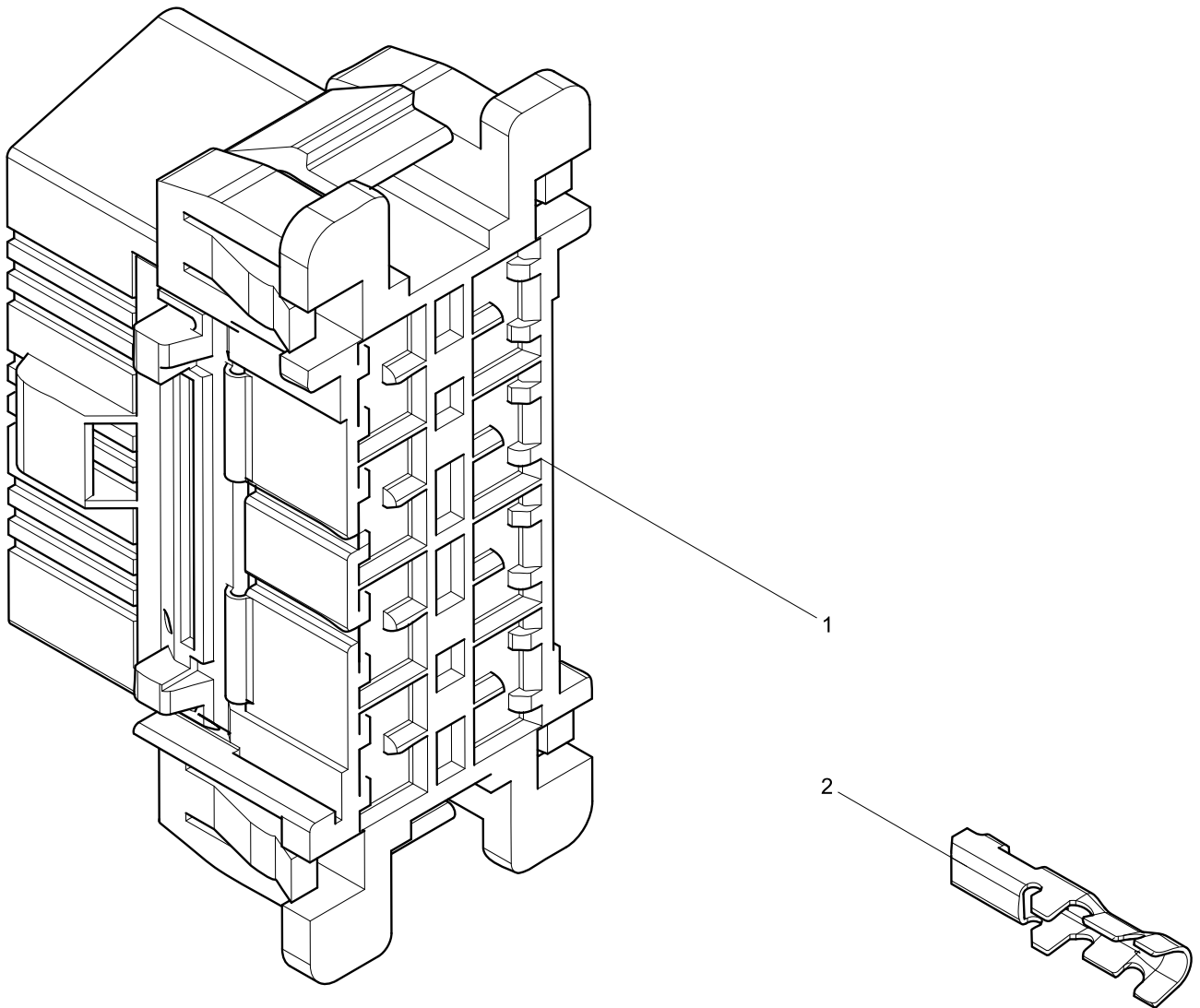

双油门踏板传感器插接件(主机厂用)(Dual accelerator pedal sensor connecting part)

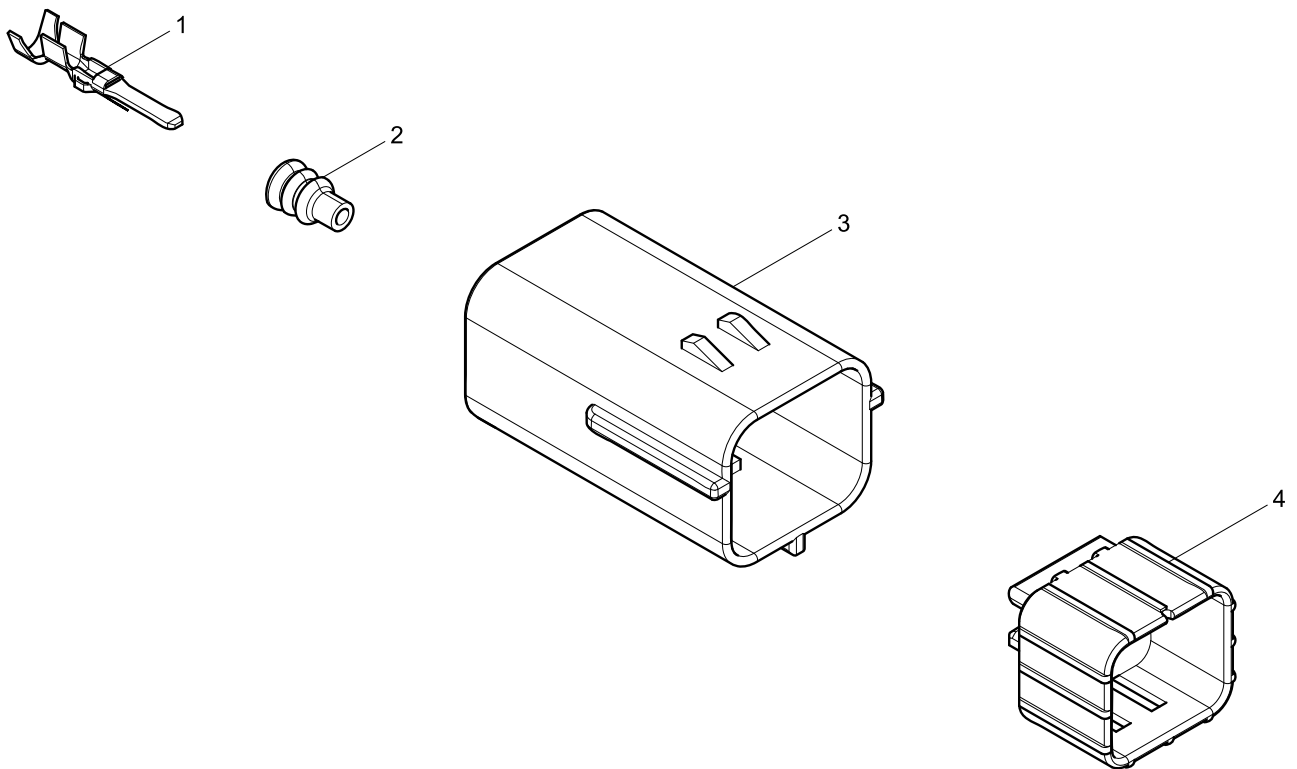

V4插接件(主机厂用)

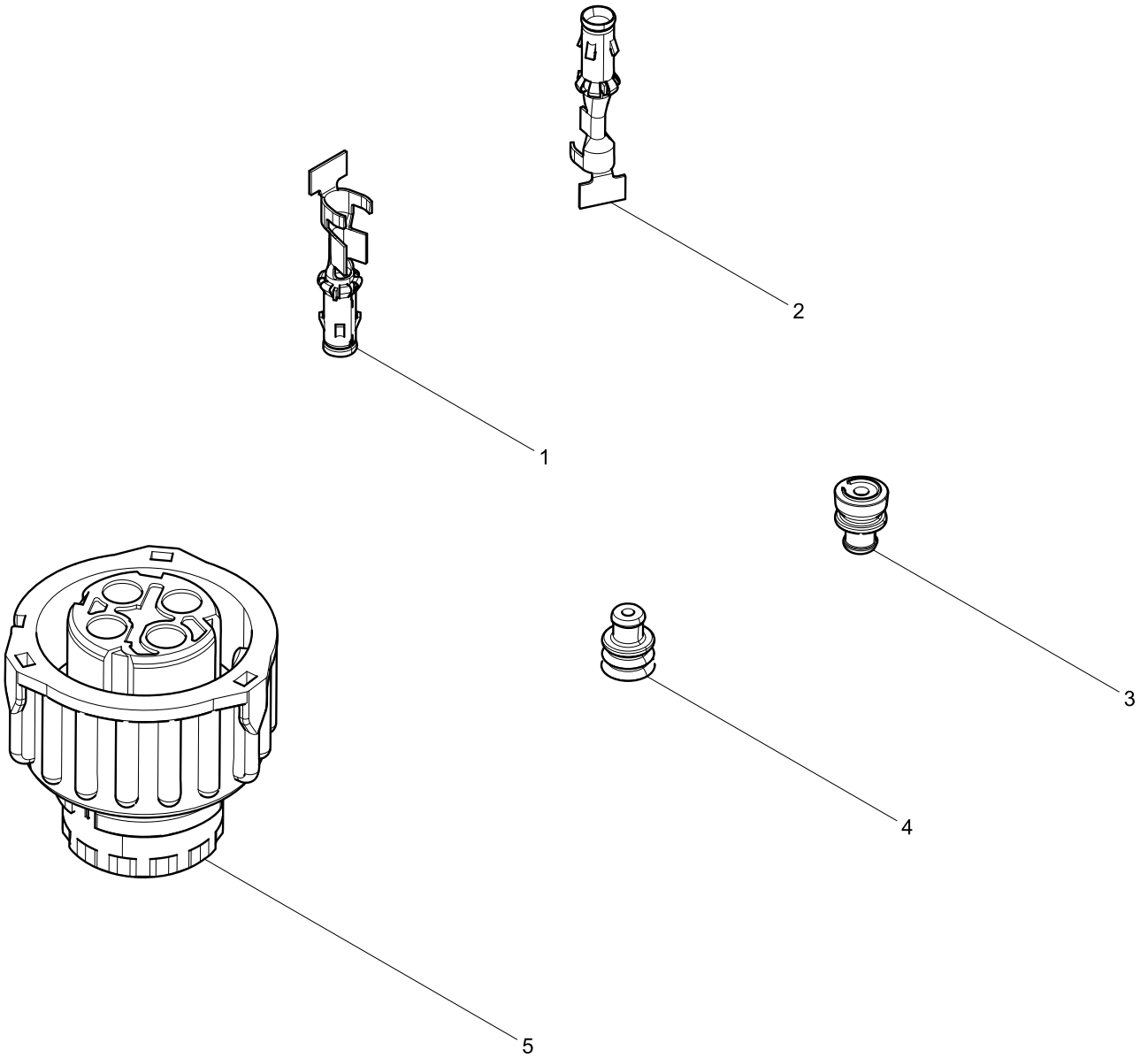

起动机接插件总成()

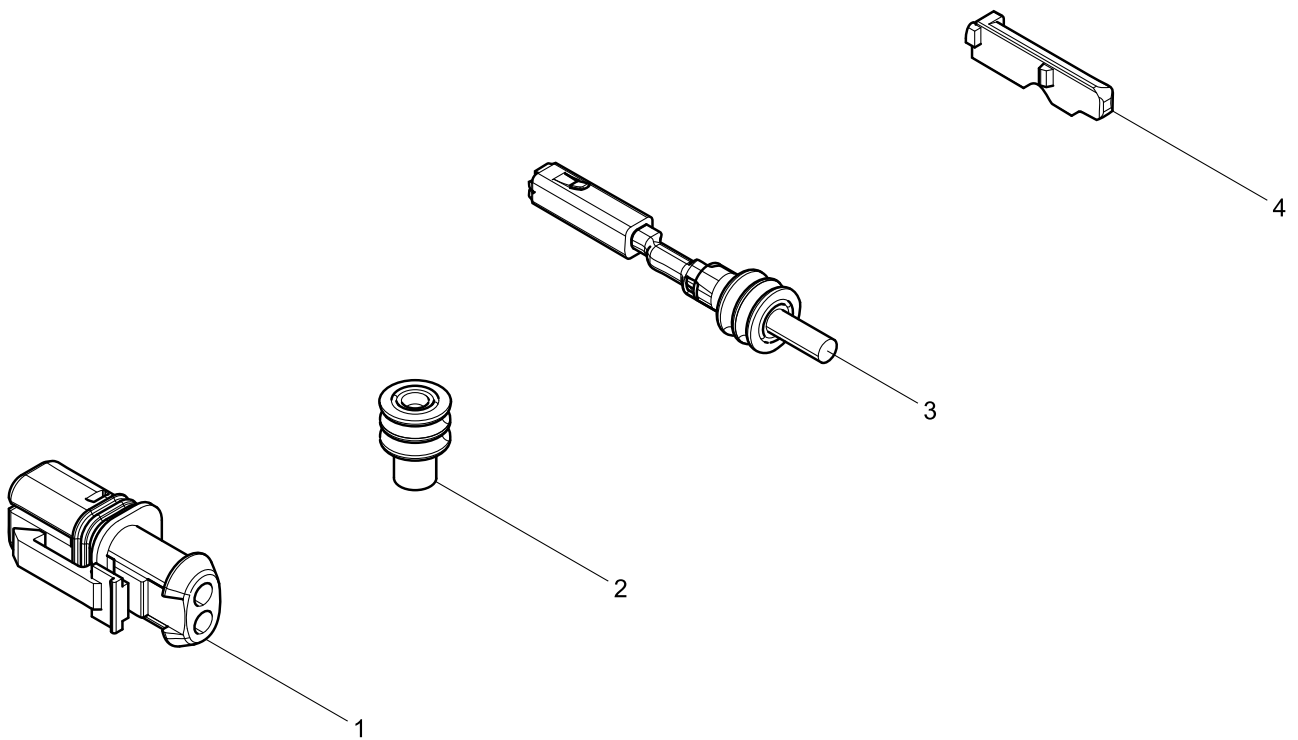

电磁风扇线圈2插件()

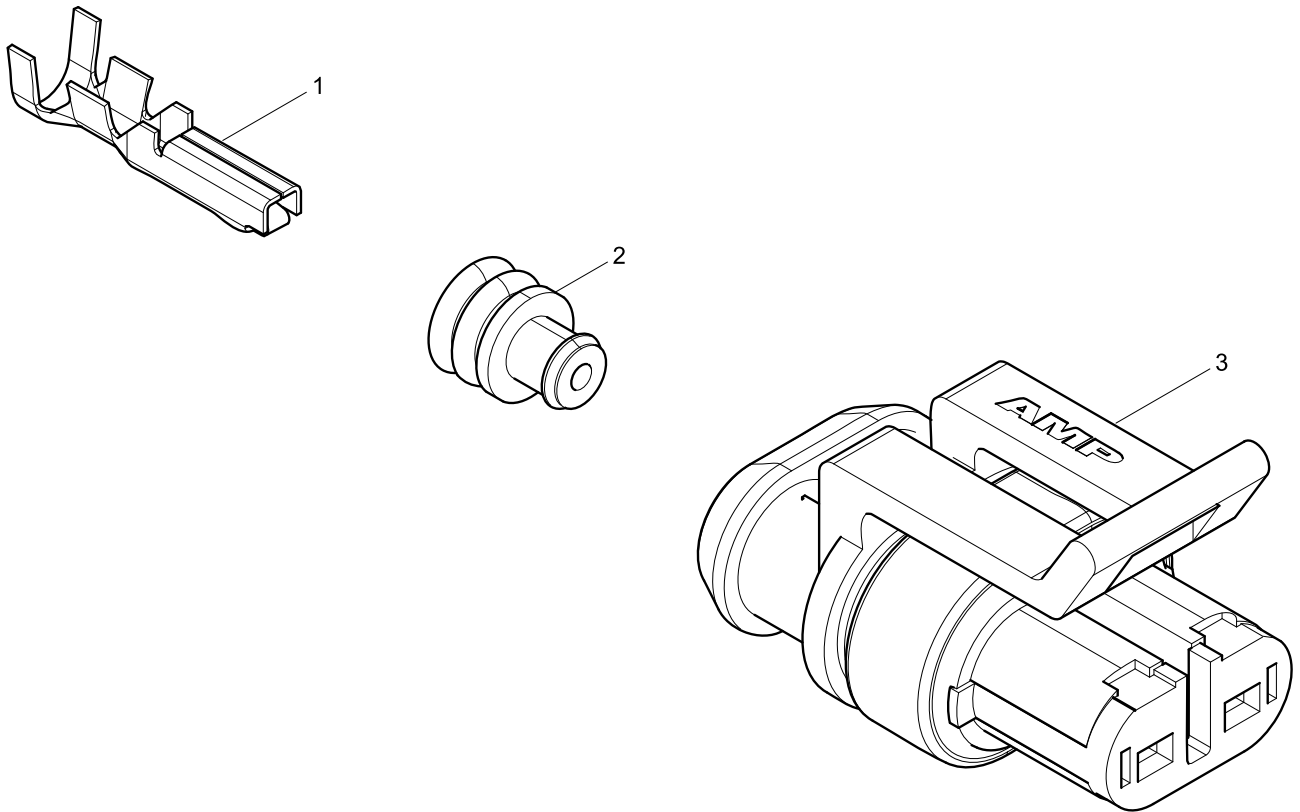

燃油水寒宝(Fuel System Protector)

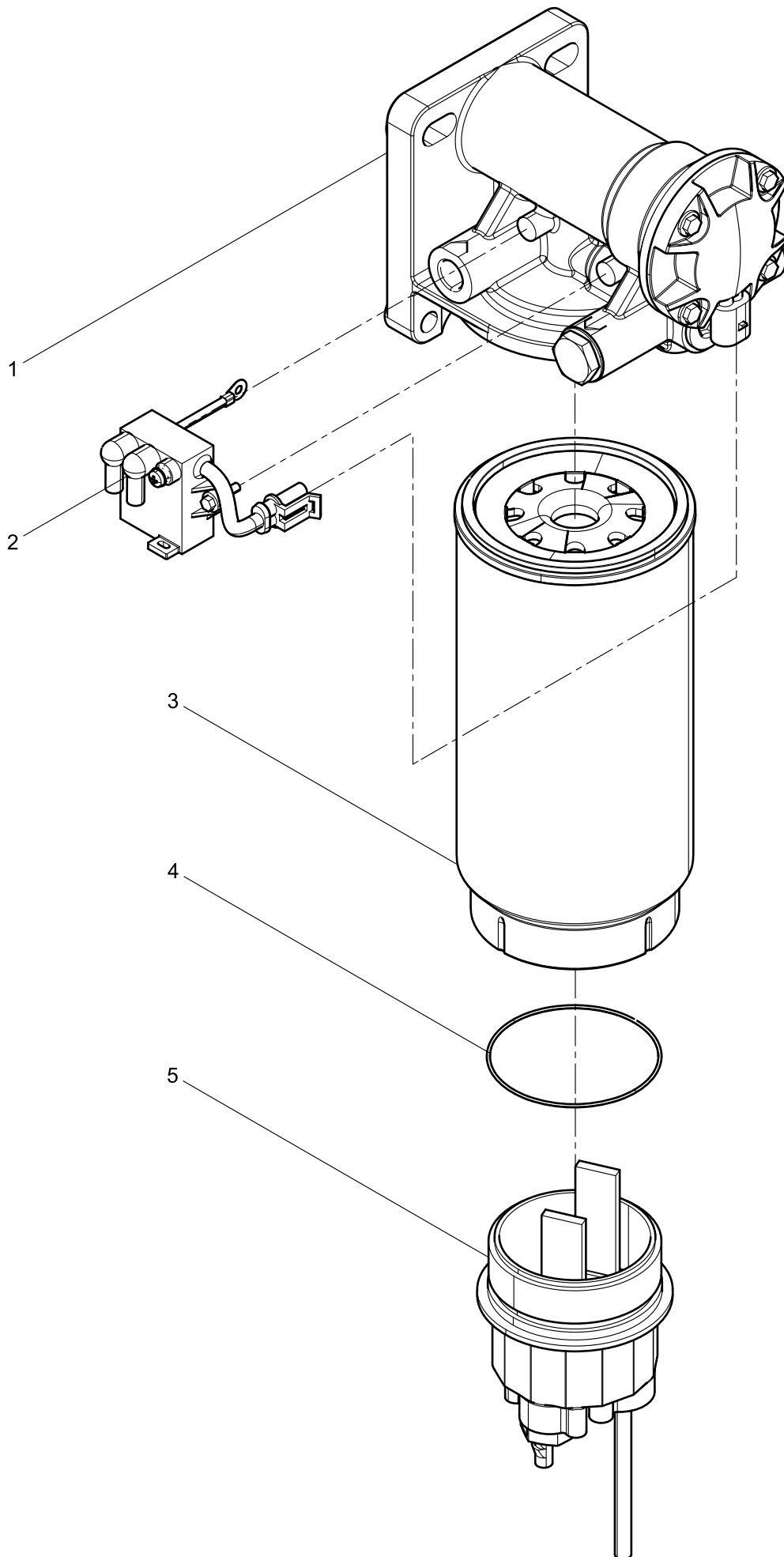

潍柴动力股份有限公司
WEICHAI POWER CO., LTD.

本材料供用户参考使用
产品参数如有变更恕不另行通知
请以产品实物为准。

This manual is for reference only,
product parameters are subject to alteration
without notice
whichever is the physical product