

—
SAFETY PRODUCTS

ASB-Series Bumper Product Manual



Read and understand this document

Please read and understand this document before using the products. Please consult your ABB JOKAB SAFETY representative if you have any questions or comments.

Suitability for use

ABB JOKAB SAFETY shall not be responsible for conformity with any standards, codes, or regulations that apply to the combination of products in the customer's application or use of the product. At the customer's request, ABB JOKAB SAFETY will provide applicable third-party certification documents identifying ratings and limitations of use that apply to the products. This information by itself is not sufficient for a complete determination of the suitability of the products in combination with the end product, machine, system, or other application or use.

The following are some examples of applications for which particular attention must be given. This is not intended to be an exhaustive list of all possible uses of the products, nor is it intended to imply that the uses listed may be suitable for the products:

- Outdoor use, uses involving potential chemical contamination or electrical interference, or conditions or uses not described in this document.
- Nuclear energy control systems, combustion systems, railroad systems, aviation systems, medical equipment, amusement machines, vehicles, and installations subject to separate industry or government regulations.
- Systems, machines, and equipment that could present a risk to life or property.

Please know and observe all prohibitions of use applicable to the products.

NEVER USE THE PRODUCTS FOR AN APPLICATION INVOLVING SERIOUS RISK TO LIFE OR PROPERTY WITHOUT ENSURING THAT THE SYSTEM AS A WHOLE HAS BEEN DESIGNED TO ADDRESS THE RISKS, AND THAT THE ABB JOKAB SAFETY PRODUCT IS PROPERLY RATED AND INSTALLED FOR THE INTENDED USE WITHIN THE OVERALL EQUIPMENT OR SYSTEM.

Table of Contents

1	Introduction	4
1.1	Scope	4
1.2	Audience	4
1.3	Prerequisites	4
1.4	Special notes.....	4
2	Overview.....	5
2.1	General description.....	5
2.2	Safety regulations	5
3	Installation and maintenance.....	6
3.1	Bumper – General.....	6
3.2	Assembly instructions	7
3.3	Electrical connections	8
3.4	Installation precautions	8
3.5	Maintenance.....	8
4	Model overview	9
4.1	Ordering details	9
5	Technical data	10
6	EC Declarations of conformity.....	15
6.1	Sentry	15
6.2	Pluto.....	16

List of Figures

Figure 1: Bumper cross section	6
Figure 2: Drill cable entry (A) for connection cable in the mounting plate.....	7
Figure 3: Mount bumper onto mounting plate	7
Figure 4: Tighten screws into plastic rail at distance (B)	7
Figure 5: Bumper electrical view	8
Figure 6: Bumper dimensions.....	9
Figure 7: Dimensioning of bumper height - overtravel distance. (F) = Force	11
Figure 8: Diagram of force – travel relationship	13

1 Introduction

1.1 Scope

The purpose of these instructions is to describe the bumper and to provide the necessary information required for installation and use.

1.2 Audience

This document is intended for authorized installation personnel.



1.3 Prerequisites

It is assumed that the reader of this document has knowledge of the following:

- Basic knowledge of ABB Jokab Safety products.
- Knowledge of machine safety.

1.4 Special notes

Pay attention to the following special notes in the document:





-  **Warning!** Danger of severe personal injury!
An instruction or procedure which, if not carried out correctly, may result in injury to the technician or other personnel.
-  **Caution!** Danger of damage to the equipment!
An instruction or procedure which, if not carried out correctly, may damage the equipment
-  **Note!** Important or explanatory information.

2 Overview

2.1 General description

Bumpers are safety equipment on transport vehicles, FTS vehicles, high-reach forklifts, freely moving systems, and everywhere where the safety systems require longer compression distance. When running against an obstacle the bumper initiates an immediate controller stop, while the bumper's soft foam core provides a long braking distance. This provides optimum protection for individuals and materials.

2.2 Safety regulations

-  **Warning!** Carefully read through the entire product manual before using the device.
-  **Warning!** The devices shall be installed by a trained electrician following the safety regulations, standards and the machinery directive.
-  **Warning!** Failure to comply with instructions, operation that is not in accordance with the use prescribed in these instructions, improper installation or handling of the device can affect the safety of people and the plant.
-  **Warning!** For installation and prescribed use of the product, the special notes in the instructions must be carefully observed and the technical standards relevant to the application must be considered.
-  **Warning!** In case of failure to comply with the instructions or standards, especially when tampering with and/or modifying the product, any liability is excluded.

3 Installation and maintenance

3.1 Bumper – General

The bumper consists of a foam core glued to an aluminium carrier profile and covered with artificial leather. The cover provides excellent protection against damage and moisture. A safety contact strip is located in the interior of the bumper and is activated under even very low-pressure loads.

The safety control unit also continuously monitors the bumper for wire breaks and defects.

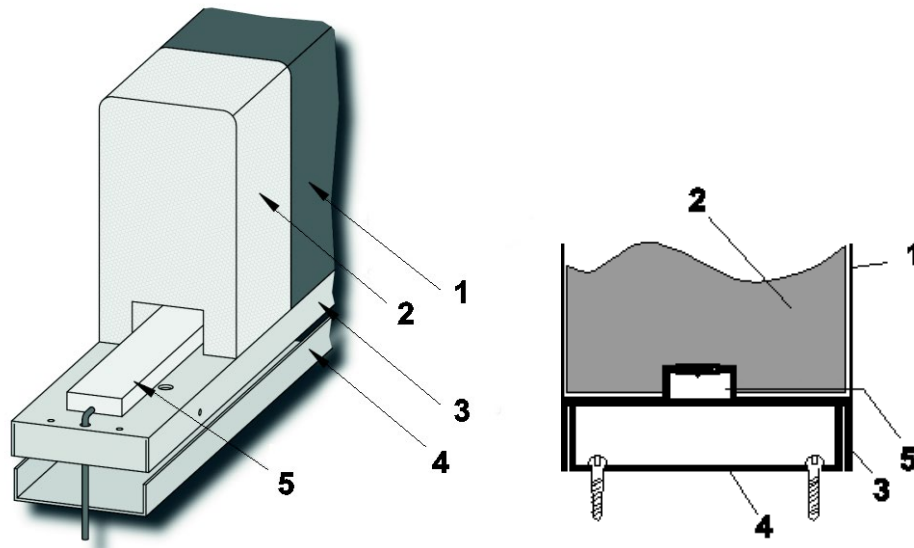

1. Artificial leather
2. Foam core
3. Carrier profile
4. Mounting profile
5. Sensing element

Figure 1: Bumper cross section

3.2 Assembly instructions

To provide safety for systems, bumpers can be connected to a safety control unit both individually as well as in series.

To mount the bumper:

1. Drill a cable entry **A (Ø 18 mm)** for the connection cable in the mounting plate. If the bumper will be connected to another bumper, yet another cable entry must be drilled.



Figure 2: Drill cable entry (A) for connection cable in the mounting plate

2. Fasten the mounting plate with M6 screws.
3. To prevent damage to the connection cable, **carefully** deburr each cable entry and provide it with protection sleeve.
4. Lead the connection cables through the protection sleeves and slide the bumper onto the mounting plate up to the stop.

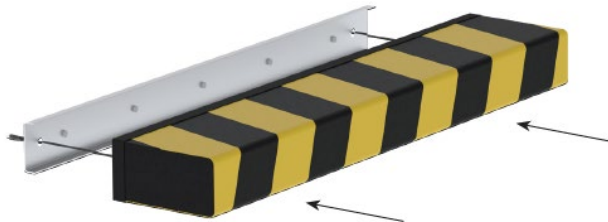

Figure 3: Mount bumper onto mounting plate

5. When everything is properly adjusted, tighten the screws supplied into the plastic rail at an even distance **B (not larger than 200 mm)**. Maximum tightening torque: 2 Nm.

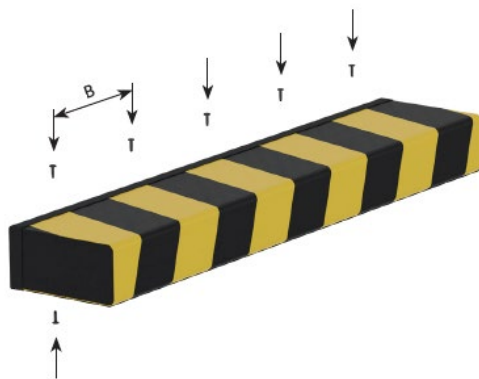

Figure 4: Tighten screws into plastic rail at distance (B)

6. Check that all installation components are firmly joined.

3.3 Electrical connections

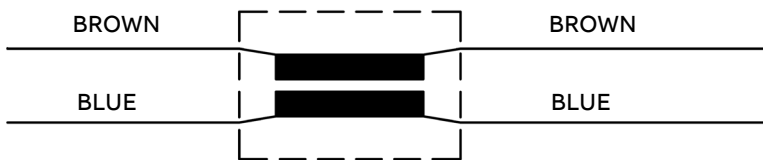

Figure 5: Bumper electrical view

Bumpers shall be connected to an ABB Jokab Safety Sentry safety relay (USR10 or USR22) or Pluto safety-PLC (A20, B20, S20, D20, B22, D45, B46, S46, AS-i, B42 AS-i or O2) which monitors the functionality of the sensing element and detects any disconnections or short-circuits in the cables. Several bumpers can be connected in series with Pluto while still retaining the same level of safety.

Note! Several bumpers cannot be connected in series with Sentry. Maximum one bumper can be connected to Sentry. Maximum five Bumpers can be connected in series with Pluto.

When pressure is applied, the active surface of the contact area in the sensing element is closed and the safety output on the safety control unit trips. A stop signal will be sent to the machine's safety circuits, stopping or preventing any dangerous movements.

3.4 Installation precautions

Warning! All safety functions shall be tested before starting up the system.

3.5 Maintenance

Warning! The safety functions and the mechanics shall be tested regularly.

Warning! In case of breakdown or damage to the product, contact the nearest ABB Jokab Safety Service Office or reseller. Do not try to repair the product yourself since it may accidentally cause permanent damage to the product, impairing the safety of the device which in turn could lead to serious injury to personnel.

Caution! ABB Jokab Safety will not accept responsibility for failure of the switch functions if the installation and maintenance requirements shown in this document are not implemented. These requirements form part of the product warranty.

4 Model overview

Order code	Description
2TLA076200R0500	Bumper ASB 60-100 black/yellow. Length in m needs to be specified on order.
2TLA076200R0600	Bumper ASB 100-200 black/yellow. Length in m needs to be specified on order.
2TLA076200R0700	Bumper ASB 150-300 black/yellow. Length in m needs to be specified on order.
2TLA076200R0800	Bumper ASB 200-400 black/yellow. Length in m needs to be specified on order.
Production cost and cables	
2TLA076200R0000	Bumper production cost, including aluminum rail and cables.

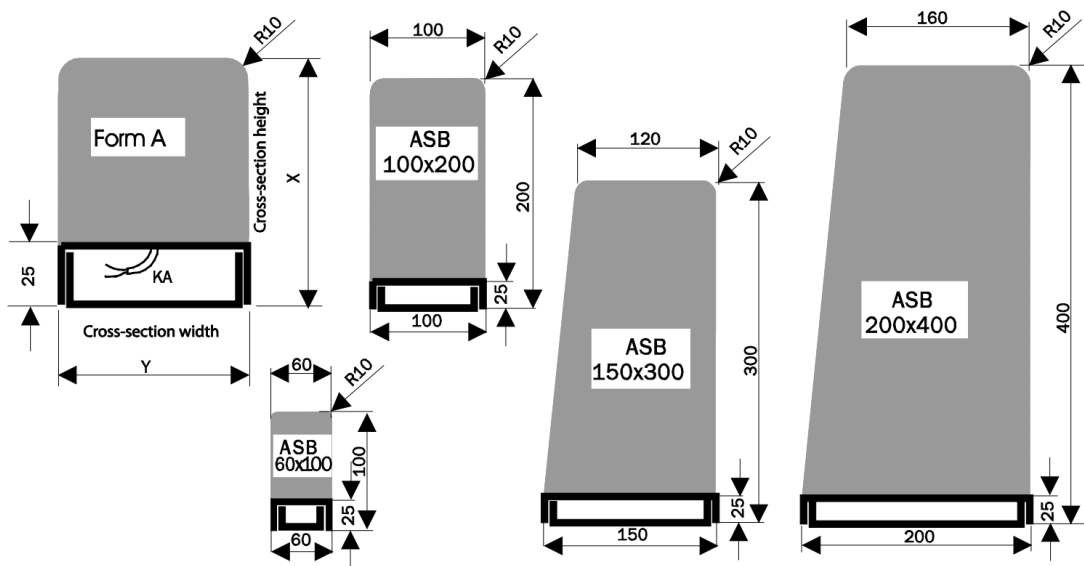

Figure 6: Bumper dimensions

4.1 Ordering details

When ordering a bumper there are two articles that needs to be ordered, one order code for production cost and cables, and one for the length of the bumper. Length should be specified in meters.

Example:

One piece of a 60-100 bumper 0.73 m long with cable:

Ordering example	
2TLA076200R0500	0.73 m
2TLA076200R0000	1 pcs

5 Technical data

Manufacturer	
Address	ABB AB JOKAB SAFETY Varlabergsvägen 11 SE-434 39 Kungsbacka Sweden
Technical data	
Actuating forces	< 150 N by test specimen Ø 80 mm (according to EN ISO 13856-3) < 400 N by test specimen 45 x 400 mm (according to EN ISO 13856-3)
Inactive edge region	0 mm
Angle of activation	± 45°
Switching cycles	> 10 000
Electric capacity	24 V, 10 mA
Protection class	IP54
Temperature range	0 °C to 50 °C
Connection cable	Length 2 x 10 cm, pluggable 2 x 0.34 mm ² (PUR black) with M8 connector 0.12m. Two 5 m extension cables are supplied with each bumper.
Maintenance	The bumper is maintenance-free. Annual service is recommended.
Standard compliance and approvals	
European Directives	2006/42/EC 2014/30/EU 2011/65/EU 2015/863
Applied harmonized standards, Machinery Directive	EN ISO 13856-3:2013 EN ISO 13849-1:2015, PLd/Cat 4* EN 62061:2005+A1:2013, SIL CL 2
* According to EN ISO 13849-2:2012, Table D.8, a fault exclusion for that the contacts in a pressure sensitive device will not close, can be made. This fault exclusion is limited up to PLd.	
Other applied standards	
Electrical safety	EN 60204-1:2006+A1:2009
Electromagnetic compatibility	EN 61326-1:2008
Approvals	
	TÜV Nord 
Information for use in USA/Canada	
Intended use	Applications according to NFPA79

Dimensioning of bumper height

Use the following key to determine the appropriate height for the bumper:

Actuating distance	15 % bumper height
Overtravel distance	60 % bumper height
No longer compressible bumper	25 % bumper height

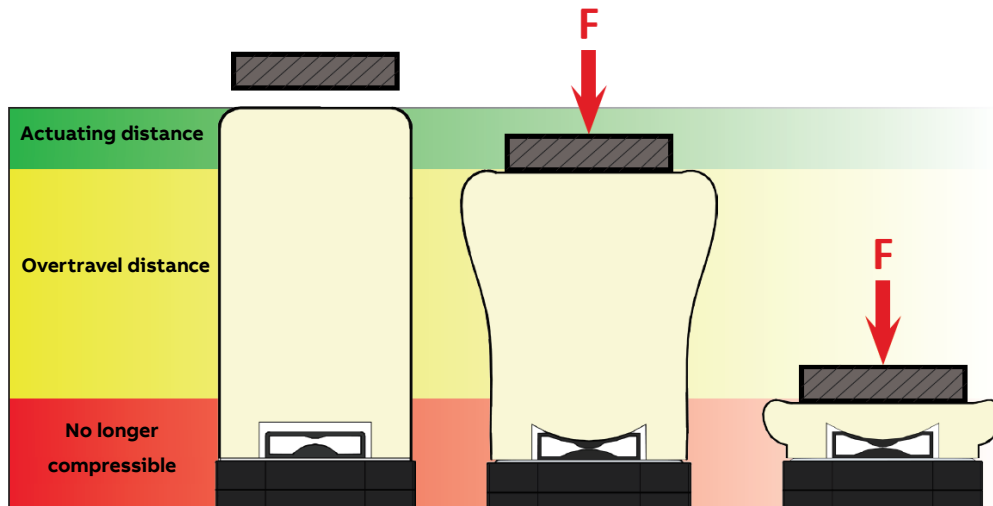

Figure 7: Dimensioning of bumper height - overtravel distance. (F) = Force

The overtravel distance can then be used to determine the appropriate bumper height. Average values by a test speed of 10 mm/s and 100 mm/s can be found in the tables below. These data are reference values compiled by laboratory tests. Even if the bumper is used as intended, external factors and reaction times of all system components can have an influence on this type of value. Considering a risk analysis of the machine to be carried out, the application of this safety component thus allows a presumption of conformity but does not release the machine manufacturer from the obligation to carry out an application-side test to demonstrate compliance with all applicable standards and directives.

Sentry USR 10 - Test-Speed 10 mm/s (Test unit round Ø 80 mm, Temp 20 °C)

Type	ASB 60-100	ASB 100-200	ASB 150-300	ASB 200-400
Actuating force FA	25.8 N	32.9 N	54.5 N	74.6 N
Actuating distance c (A)	6.9 mm	28.5 mm	54.8 mm	62.6 mm
Overtravel distance d (B1) at 250 N	58.6 mm	120.2 mm	171.4 mm	231.5 mm
Overtravel distance f (B2) at 400 N	61.5 mm	126.2 mm	187.3 mm	264.6 mm
Overtravel distance h-c (C) at 600 N	63.4 mm	130.5 mm	195.8 mm	279.7 mm

Sentry USR 10 - Test-Speed 100 mm/s (Test unit round Ø 80 mm, Temp 20 °C)

Type	ASB 60-100	ASB 100-200	ASB 150-300	ASB 200-400
Actuating force FA	35.1 N	43.3 N	72.3 N	95.1 N
Actuating distance c (A)	7.6 mm	34.6 mm	57.7 mm	78.6 mm
Overtravel distance d (B1) at 250 N	57.1 mm	113.1 mm	163.9 mm	208.0 mm
Overtravel distance f (B2) at 400 N	60.3 mm	119.9 mm	183.3 mm	245.8 mm
Overtravel distance h-c (C) at 600 N	62.5 mm	124.7 mm	192.6 mm	262.5 mm

Sentry USR 22 - Test-Speed 10 mm/s (Test unit round Ø 80 mm, Temp 20 °C)

Type	ASB 60-100	ASB 100-200	ASB 150-300	ASB 200-400
Actuating force FA	28.8 N	32.6 N	55.9 N	73.8 N
Actuating distance c (A)	7.4 mm	28.6 mm	54.3 mm	65.0 mm

Overtravel distance d (B1) at 250 N	58.0 mm	120.4 mm	173.8 mm	231.9 mm
Overtravel distance f (B2) at 400 N	61.3 mm	126.7 mm	188.8 mm	263.1 mm
Overtravel distance h-c (C) at 600 N	63.5 mm	130.7 mm	197.3 mm	277.2 mm

Sentry USR 22 - Test-Speed 100 mm/s (Test unit round Ø 80 mm, Temp 20 °C)

Type	ASB 60-100	ASB 100-200	ASB 150-300	ASB 200-400
Actuating force FA	33.9 N	44.3 N	69.9 N	99.3 N
Actuating distance c (A)	7.3 mm	34.5 mm	60.7 mm	76.3 mm
Overtravel distance d (B1) at 250 N	57.1 mm	113.4 mm	162.8 mm	208.7 mm
Overtravel distance f (B2) at 400 N	60.5 mm	120.4 mm	180.3 mm	246.9 mm
Overtravel distance h-c (C) at 600 N	63.0 mm	124.6 mm	189.5 mm	263.9 mm

Pluto - Test-Speed 10 mm/s (Test unit round Ø 80 mm, Temp 20 °C)

Type	ASB 60-100	ASB 100-200	ASB 150-300	ASB 200-400
Actuating force FA:				
Single Pluto	28.5 N	31.4 N	56.5 N	75.1 N
Pluto including Pluto bus*	30.0 N	35.0 N	60.0 N	80.0 N
Actuating distance c (A):				
Single Pluto	7.6 mm	28.5 mm	55.8 mm	62.5 mm
Pluto including Pluto bus*	8.0 mm	28.9 mm	56.2 mm	62.9 mm
Overtravel distance d (B1) at 250 N:				
Single Pluto	58.3 mm	120.2 mm	173.8 mm	231.4 mm
Pluto including Pluto bus*	57.9 mm	119.8 mm	173.4 mm	231.0 mm
Overtravel distance f (B2) at 400 N:				
Single Pluto	60.9 mm	126.4 mm	188.4 mm	265.2 mm
Pluto including Pluto bus*	60.5 mm	126.0 mm	188.0 mm	264.8 mm
Overtravel distance h-c (C) at 600 N:				
Single Pluto	63.2 mm	130.7 mm	196.6 mm	281.0 mm
Pluto including Pluto bus*	62.8 mm	130.3 mm	196.2 mm	280.6 mm

*Calculated worst case value

Pluto - Test-Speed 100 mm/s (Test unit round Ø 80 mm, Temp 20 °C)				
Type	ASB 60-100	ASB 100-200	ASB 150-300	ASB 200-400
Actuating force FA:				
Single Pluto	39.1 N	45.6 N	71.5 N	94.1 N
Pluto including Pluto bus*	45.0 N	50.0 N	75.0 N	100.0 N
Actuating distance c (A):				
Single Pluto	8.9 mm	34.2 mm	61.9 mm	74.9 mm
Pluto including Pluto bus	12.9 mm	38.2 mm	65.9 mm	78.9 mm
Overtravel distance d (B1) at 250 N:				
Single Pluto	56.1 mm	112.6 mm	161.4 mm	204.5 mm
Pluto including Pluto bus*	52.1 mm	108.6 mm	157.4 mm	200.5 mm
Overtravel distance f (B2) at 400 N:				
Single Pluto	59.3 mm	119.7 mm	178.8 mm	244.0 mm
Pluto including Pluto bus*	55.3 mm	115.7 mm	174.8 mm	240.0 mm
Overtravel distance h-c (C) at 600 N:				
Single Pluto	61.6 mm	124.4 mm	188.0 mm	262.9 mm
Pluto including Pluto bus*	57.6 mm	120.4 mm	184.0 mm	258.9 mm

*Calculated worst case value

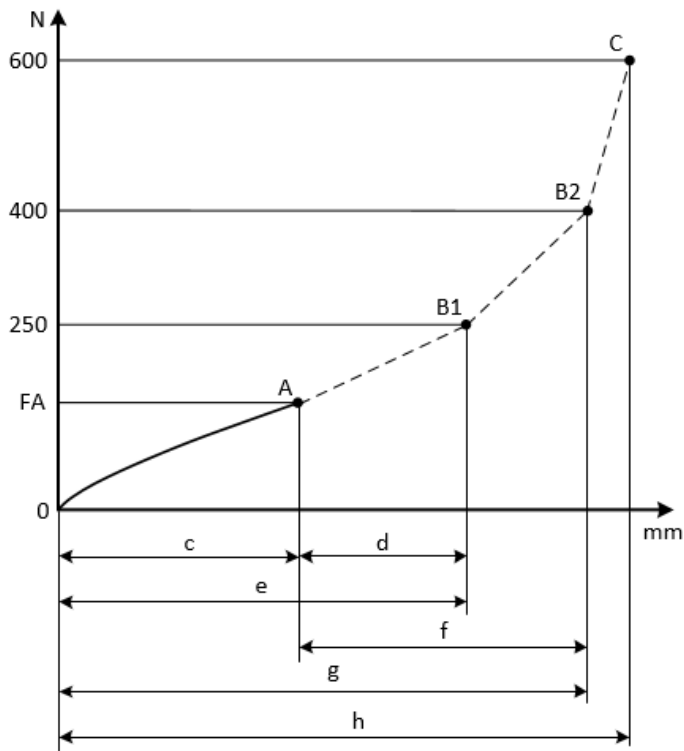

Figure 8: Diagram of force – travel relationship

Mounting

Cabinet	The safety control unit shall be mounted in a cabinet with IP rating of at least IP54	
Max total length of bumper	Sentry	25 m
	Pluto	15 m
Max no. of bumpers	Sentry	1
	Pluto	5

Chemical resistance

Effect solvent	Wipe	1 h	24 h
Water	1	1	1
Detergent	1	1	1
Caustic soda 10%	1	1	1
Ammonia 10%	1	1	1
Acetic acid 10%	1	1	1
Sulphuric acid 10%	1	1	1
Ethyl alcohol	1	2	3
Ethyl acetate	4	5	6
Acetone	4	5	6
Gasoline	1	2	3
Diesel	1	1	1
Engine oil	1	1	2
Transmission oil	1	1	2

1 = No effect	Permanent contact allowed
2 = Few effects	Contact allowed
3 = Medium effects	Contact allowed
4 = Noticeable effects	Contact restricted
5 = Strong effects	Very brief contact
6 = Extreme effects	Avoid contact



Note!

The information given is based on data obtained from the respective material suppliers. Although all efforts have been made, unforeseen factors can have a considerable effect on the generally applied indications during practical use therefore this information must be used as a general guide only.

6 EC Declarations of conformity

6.1 Sentry



EC Declaration of conformity

(according to 2006/42/EC, Annex 2A)

We ABB AB
JOKAB Safety
Varlabergsvägen 11
SE-434 39 Kungsbacka
Sweden

declare that the safety components of ABB AB manufacture with type designations and safety functions as listed below, is in conformity with the Directives
2006/42/EC - Machinery
2014/30/EU - EMC
2011/65/EU – RoHS
2015/863 – RoHS3

Authorised to compile the technical file

ABB AB
JOKAB Safety
Varlabergsvägen 11
SE-434 39 Kungsbacka
Sweden

Product

Safety bumper
ASB 60-100
ASB 100-200
ASB 150-300
ASB 200-400
together with
Safety relay Sentry
USR10, USR22

EC type-examination certificate

44 205 161355 18

Notified Body

TÜV Nord CERT GmbH
Langemarckstrasse 20
45141 Essen
Germany
Notified Body No. 0044

Used harmonized standards

EN ISO 12100:2010, EN ISO 13856-3:2013, EN ISO 13849-1:2015,
EN 62061:2005+A2:2015, EN 60204-1:2006+A1:2009,
EN 60664-1:2007, EN 61000-6-2:2005, EN 61000-6-4:2007

Other used standards

EN 61508:2010

Tobias Gentzell
R&D Manager
Kungsbacka 2019-06-07

6.2 Pluto



EC Declaration of conformity

(according to 2006/42/EC, Annex 2A)

We ABB AB
JOKAB Safety
Varlabergsvägen 11
SE-434 39 Kungsbacka
Sweden

declare that the safety components of ABB AB manufacture with type designations and safety functions as listed below, is in conformity with the Directives
2006/42/EC - Machinery
2014/30/EU - EMC
2011/65/EU – RoHS
2015/863 – RoHS3

Authorised to compile the technical file

ABB AB
JOKAB Safety
Varlabergsvägen 11
SE-434 39 Kungsbacka
Sweden

Product

Safety bumper
ASB 60-100
ASB 100-200
ASB 150-300
ASB 200-400
together with
Safety PLC Pluto
A20, B20, S20, D20, B22, D45,
B46, S46, AS-i, B42AS-i, O2

EC type-examination certificate

44 205 16135522

Notified Body

TÜV Nord CERT GmbH
Langemarckstrasse 20
45141 Essen
Germany
Notified Body No. 0044

Used harmonized standards

EN ISO 12100:2010, EN ISO 13856-3:2013, EN ISO 13849-1:2015,
EN 62061:2005+A2:2015, EN 60204-1:2006+A1:2009,
EN 60664-1:2007, EN 61000-6-2:2005, EN 61000-6-4:2007

Other used standards

EN 61508:2010

Tobias Gentzell
R&D Manager
Kungsbacka 2019-06-07

www.abb.com/jokabsafety

Original