

# KRS Servo Series

Thank you for purchasing the KRS Servo Series. Please be sure to thoroughly read through this instruction manual before use. Instruction manuals, servo command reference material, information relating to this product, and the software required to change settings when connected to a PC is available for download from our website.

\*You need the "Dual USB Adapter" (Part number O2116) in order to connect this product to a PC.

**Information related to this product can be found at the following website:**

**<http://kondo-robot.com/>**

**"Customer center" → "Information Support" → "ICS & KRS Servo Development materials" → "Software Samples"**

ICS 3.5 Manager, Command Reference, Dual USB Adapter, HS Manual, KO Driver etc.

**⚠ Warning! Improper use of this product could result in serious injury or death.**

● **Keep all body parts away from this product during operation. Always pay attention while operating this product.**

※There is a risk of bone fracture and/or amputation of fingers or other body parts if they get caught up in the moving parts of this product. Furthermore, this product can become extremely hot when overloaded. Take care not to burn yourself when handling.

**⚠ Caution! Improper use of this product could result in injury or damage to property.**

- Check the input signal and source voltage before operating this product.
- Pay attention to the orientation of the connectors, and ensure they are correctly plugged in.
- Do not use this product in a place where there it may get wet.

- Do not dismantle or modify this product in a way that is not endorsed by this company.
  - ※Do not use signals or voltages outside the specified range. Doing so may result in malfunction or damage to the product.
  - ※Reversal of the polarity of the power source will damage the product.
  - ※Allowing water to get inside this product may cause damage and/or malfunction.

## Precautions for Use

- This product is designed for use in robots. It cannot be used in other products such as radio controlled cars.
- Please check that the servos move freely through their range of motion when installing into your robot. Backlash or looseness in bracketing may cause an unnecessarily high load on the servos, increasing power consumption and reducing the lifespan of the product.
- Dry cell batteries may not be sufficiently powerful enough to operate this product.
- The maximum range of motion this product is capable of will depend on the input signal.
- Take extra care when attempting to use home-built control boards to control these servos. Use under extreme conditions may result in under performance and a heavily reduced life-span of this product. If you have questions relating to the use and/or output of this product, please visit our website at <http://www.kondo-robot.com>. If you cannot find the information you require, contact our service department with your inquiry. Please note that we are cannot answer questions on control programming. Thank you for your understanding.

● **Do not maintain the maximum torque output for an extended period of time.**

The maximum indicated torque output of this product is only intended for short periods of time. It is not recommended to use this product in a state of maximum torque output for extended periods of time. Please consider this when designing your robots.

● **Avoid frequent repetitive movements.**

Rotating the servo back and forth a lot in a short period of time will cause excess heat to build up and may result in damage to the product.

● **Ensure each servo receives enough power when connecting in a daisy chain pattern.**

Theoretically, this product can be daisy chained up to 32 units. Daisy chaining this product may result in a weakened signal, a lack of power, or wiring burning out. When daisy-chaining this product, we recommend running a separate signal wire and power wire with sufficient capacity to power the servos. This is to reduce the chance of a weak signal as a consequence of a loop connection.

# Specifications and Accessories

※Changes or improvements may be made to this product without prior notice.

## Specs.

### KRS-6003RHV ICS

Size : L 51 mm × W32 mm × H39.5 mm

Operating voltage : 9 ~ 12V

Weight : 103g

Maximum operating angle : 270° (±135°)

Maximum current : 6.1A (@11.1V)

Gear material : Aluminum+Stainless

Communication standards : ICS3.5(Serial/PWM)

Control Boards : RCB-4HV, KCB-5, RCB-3HV

## Accessories

【 1 pc 】  
HV Connection Cable (400mm) × 1  
Aluminum Cramp Horn × 1

【 6 pcs set 】  
HV Connection Cable (400mm) × 6  
Aluminum Cramp Horn × 6

【 18 pcs set 】  
HV Connection Cable (400mm) × 18  
Aluminum Cramp Horn × 18

## Performance

### KRS-6003RHV ICS

Torque : 67.0kg · cm

Speed : 0.22s/60°

Reduction ratio : 362.88 : 1

※Torque/Speed@11.1V

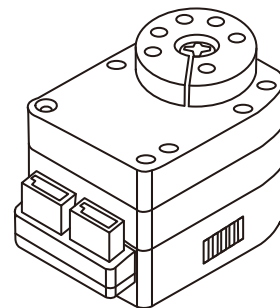

### KRS-4034/4033/4032HV/4031HV ICS

Size : L43 mm × W32 mm × H32.5 mm

Operating voltage : 9 ~ 12V

Weight : 61.2g / 61.4g / 61.2g / 55.2g

Maximum operating angle : 270° (±135°)

Maximum current : 3.1A(@11.1V)

Gear material : Aluminum+Steel / POM

Communication standards : ICS3.5(Serial/PWM)

Control Boards : RCB-4HV, KCB-5, RCB-3HV

【 1 pc 】  
Connection Cable G (400mm) × 1  
M3-8 Low Head Horn Screw × 1

【 6 pcs set 】  
Connection Cable G (400mm) × 6  
M3-8 Low Head Horn Screw × 8

### KRS-4034HV

Torque : 41.7kg · cm

Speed : 0.17s/60°

Reduction ratio : 381.2 : 1

### KRS-4033HV

Torque : 30.6kg · cm

Speed : 0.12s/60°

Reduction ratio : 249.6 : 1

### KRS-4032HV

Torque : 19.8kg · cm

Speed : 0.08/60°

Reduction ratio : 167.2 : 1

### KRS-4031HV ICS

Torque : 13.0kg · cm

Speed : 0.16sec/60°

Reduction ratio : 346.6 : 1

※Torque/Speed@11.1V

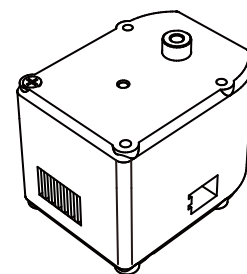

### KRS-2572HV/2552RHV/2542HV ICS

Size : L41 mm × W21 mm × H30.5 mm

Operating voltage : 9 ~ 12V

Weight : 47.7g / 41.5g / 35.5g

Maximum operating angle : 270° (±135°)

Maximum current : 1.3A (@11.1V)

Gear material : Metal + (Nylon:2542)

Communication standards : ICS3.5(Serial/PWM)

Control Boards : RCB-4HV, KCB-5, RCB-3HV

【 1 pc 】  
ZH Connection Cable A (300mm) × 1  
M3-8 Low Head Horn Screw × 1 : 2552  
2.6-6 Flat Head Screw × 1 : 2542

【 6 pcs set 】  
ZH Connection Cable A (300mm) × 8  
ZH Connection Cable B (200mm) × 2  
M3-8 Low Head Horn Screw × 10 : 2552  
2.6-6 Flat Head Screw × 10 : 2542

### KRS-2572HV

Torque : 25.0kg · cm

Speed : 0.13sec/60°

Reduction ratio : 309.11 : 1

### KRS-2552RHV

Torque : 14.0kg · cm

Speed : 0.14sec/60°

Reduction ratio : 312.40 : 1

### KRS-2542HV ICS

Torque : 11.0kg · cm

Speed : 0.12sec/60°

Reduction ratio : 193.18 : 1

※Torque/Speed@11.1V

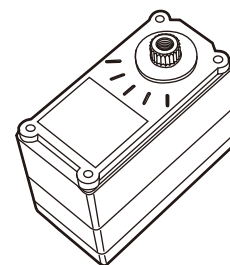

### KRS-3304 ICS

Size : L32.5 mm × W26.0 mm × H26.0 mm

Operating voltage : 6.0 ~ 7.4V

Weight : 33.7g

Maximum operating angle : 270° (±135°)

Maximum current : 2.2A (@7.4V)

Gear material : Metal

Communication standards : ICS3.5

Control Boards : RCB-4HV, KCB-5, RCB-3HV

【 1 pc 】  
ZH Connection Cable B (300mm) × 1  
M3-8 Low Head Horn Screw × 1

【 6 pcs set 】  
ZH Connection Cable A (300mm) × 4  
ZH Connection Cable B (200mm) × 2  
M3-8 Low Head Horn Screw × 6

【 18 pcs set 】  
ZH Connection Cable A (300mm) × 12  
ZH Connection Cable B (200mm) × 6  
M3-8 Low Head Horn Screw × 18

### KRS-3304 ICS

Torque : 13.9kg · cm (7.4V)  
11.2kg · cm (6.0V)

Speed : 0.11sec/60° (7.4V)  
0.13sec/60° (6.0V)

Reduction ratio : 289.22 : 1

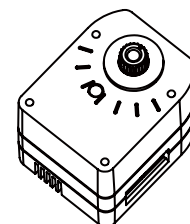

### KRS-3204 ICS

Size : L33.0 mm × W15.0 mm × H26.0 mm

Operating voltage : 6.0 ~ 7.4V

Weight : 27.2g

Maximum operating angle : 270° (±135°)

Maximum current : 2.2A (@7.4V)

Gear material : Metal

Communication standards : ICS3.5

Control Boards : RCB-4HV, KCB-5, RCB-3HV

※Cable length : 350mm (Fixed)

【 1 pc 】  
M3-8 Low Head Horn Screw × 1 本

【 6 pcs set 】  
M3-8 Low Head Horn Screw × 6 本

【 18 pcs set 】  
M3-8 Low Head Horn Screw × 18 本

### KRS-3204 ICS

Torque : 9.3kg · cm (7.4V)  
7.5kg · cm (6.0V)

Speed : 0.13sec/60° (7.4V)  
0.18sec/60° (6.0V)

Reduction ratio : 290.17 : 1

※Case screw : 1.7mm

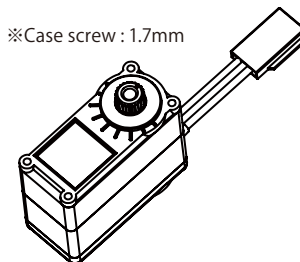

## Important Points

■ KRS-3204 and 3304 servos are not suitable for high voltage applications. Operate at less than 7.4 volts.

■ Our high voltage servo products operate at a different voltage to this product. Using high and low voltage servos in the same robot requires separate circuitry.

# Connecting the Servos

Using the included (or optional) cables, connect one end to the signal terminal of the control board, and the other end to the signal terminal of the servo. The two signal terminals on the servos are internally connected in parallel, so you may connect to either one. Please refer to page 6 of this manual if you wish to connect multiple servos using the same terminal in a 'multi-drop' arrangement.

## Servo Connector

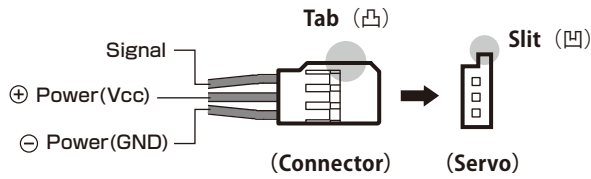

## ZH Connector

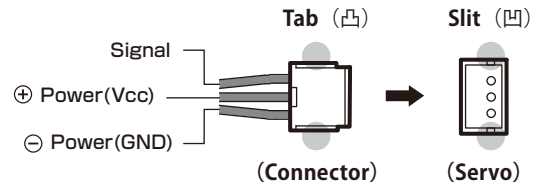

## 6000 Series

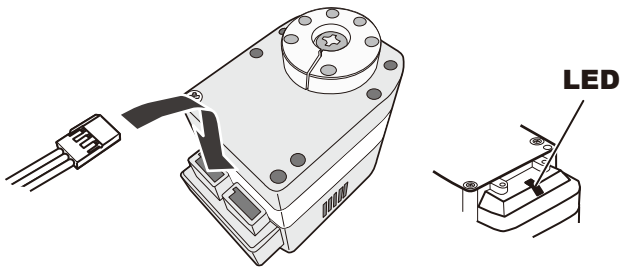

※6003HV Red Version is serial communication only.

## 2500 Series

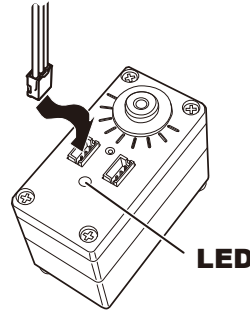

## 4000 Series

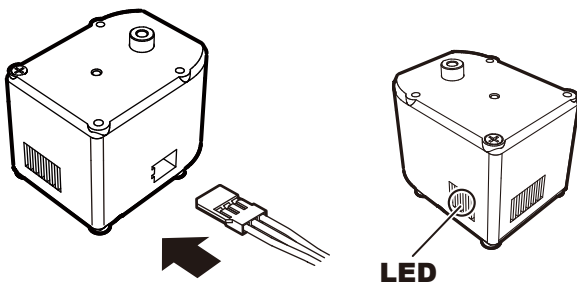

● Plug the connectors into the terminals vertically. (The plastic part of the connector will sit flush with the servo when connected correctly)

## 3300 Series

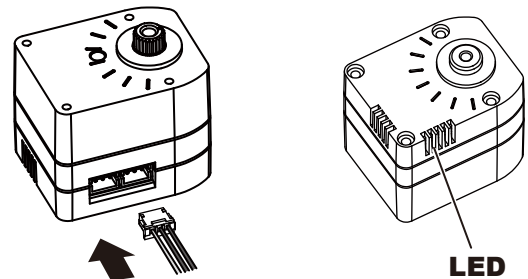

## 3200 Series

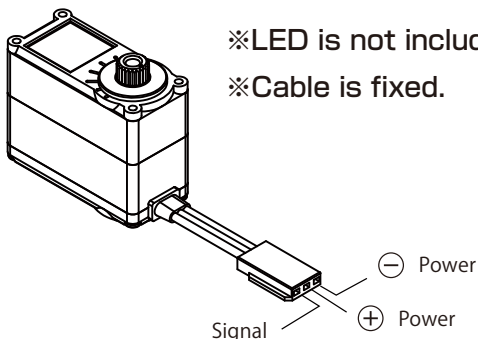

※LED is not included.  
 ※Cable is fixed.

## ■ Connecting to a PC

Using the connection adapter described below together with the ICS manager software on your PC to change all the servo parameter settings and assign servo IDs. You may also control your servos directly via your PC or compact motherboard.

- Dual USB Adapter HS (sold separately)
- KO Driver (free download)
- ICS 3.5 Manager (free download)
- ICS 3.5 Command Reference (free download)  
 (The old version of ICS is also available for download on the website)

## ■ Connection to the KONDO Control Board

Using the KONDO control board in conjunction with these servos allows you to use either our "Heart to Heart" robot control software, or C programming language. It also allows for the use of Bluetooth and Wi-Fi connections, gyros and accelerometers, and wireless control.

- ※Refer to pages 6 through 9 of this manual for further details about ICS management software and communication systems.
- ※Refer to page 10 of this manual for further details about optional parts.
- ※Refer to each manual for further details.

# Anchoring Servos

Servos can be anchored to home-made frames or brackets using up to 8 screws. Refer to the table in the diagram below for recommended screw sizes.

○6000/4000 series: (When frame thickness is 2mm)

1) Remove two screws shown in diagram below. 2) Secure upper and lower bracketing using designated screws.

○2000/3000 series: (When frame thickness is 1mm)

1) Remove screws from servo case. 2) Secure servo to frame using screws removed from case and designated screws.

※Removing the screws from the servo casing may result in the casing coming apart. Take care not to let the internal parts fall out or come apart. ※Screws for anchoring the servos are sold separately. Either purchase our optional screws or use commercially available screws.

※For details on screw locations, refer to the external diagrams included after page 12 in this manual. You can also download external diagrams from our website.

## 6000 Series

Please remove 2 screws, if you mount frames both sides. Please keep screws for reuse.

●M2.6-15 (Frame t=2mm)  
x 4  
\*Sold separately

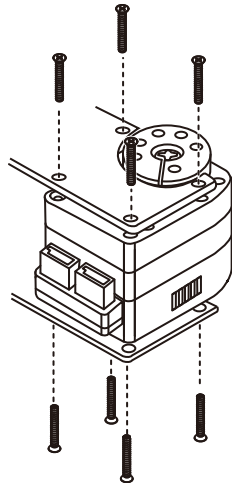
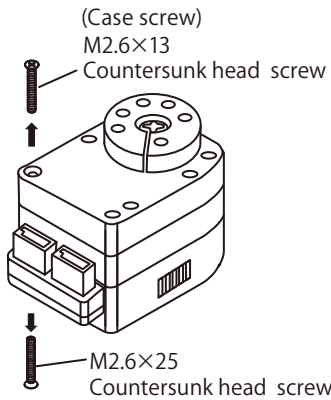

●M2.6-27 (Frame t=2mm)  
x 4  
\*Sold separately

## 4000 Series

Please remove 2 screws, if you mount frames both sides. Please keep screws for reuse.

●M2-15 (Frame t=2mm)  
No.01127 (50pcs)  
x 8  
\*Sold separately

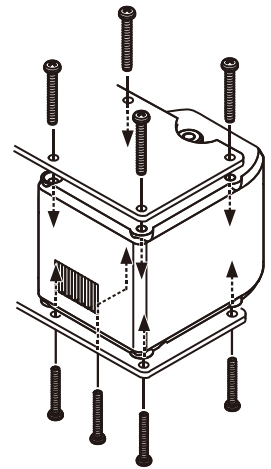
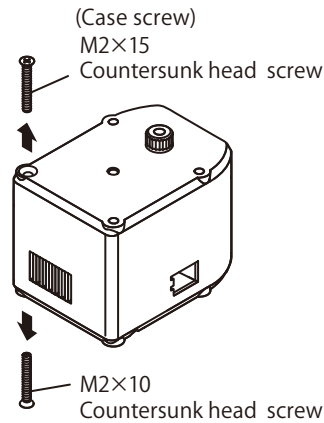

## 2500 Series

(Case screw)  
●M2x24  
x 4  
\*Reuse

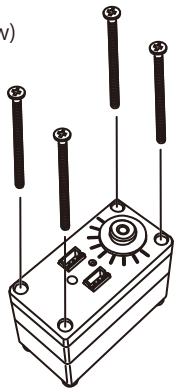

(Frame t=1mm)  
●2-5 Low Head Tapping Screw  
No.02084 (100pcs)  
x 4  
\*Sold separately

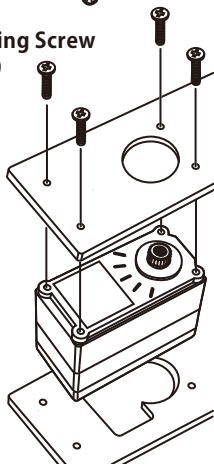

## 3300 Series

(Case screw)  
●2x20 Low Head Tapping Screw  
x 4  
\*Reuse

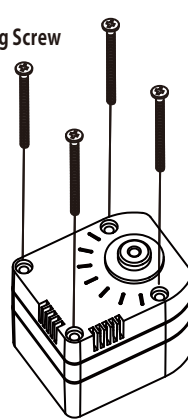

(Frame t=1mm)  
●2-5 Low Head Tapping Screw  
No.02084 (100pcs)  
x 4  
\*Sold separately

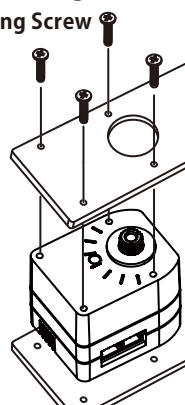

## 3200 Series

(Case screw)  
●M1.7x20 Low Head Screw  
x 4  
\*Reuse

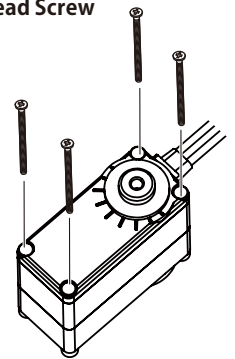

(Frame t=1mm)  
●1.7-5 Low Head Tapping Screw  
No.02162 (100pcs)  
x 4  
\*Sold separately

\*Do not use 2mm screw. Cases will be damaged.

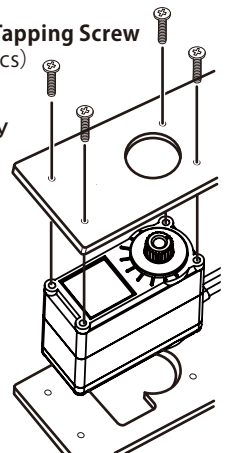

# Installation of Servo Horns

All servos on one side and Free horns can be used to achieved dual support. All our servos include the screws required to secure the servo horn to the servo. ( Aluminum clamp horns are included with the 6000 series) Only install optional parts that comply with our servo horns.

※See our website for more information.

## 6000 Series

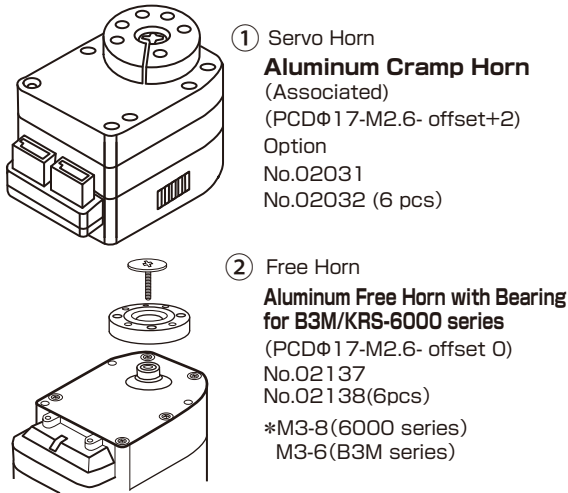

- ① Servo Horn  
**Aluminum Cramp Horn**  
(Associated)  
(PCDΦ17-M2.6- offset+2)  
Option  
No.02031  
No.02032 (6 pcs)
- ② Free Horn  
**Aluminum Free Horn with Bearing for B3M/KRS-6000 series**  
(PCDΦ17-M2.6- offset 0)  
No.02137  
No.02138(6pcs)  
\*M3-8(6000 series)  
M3-6(B3M series)

## 4000 Series

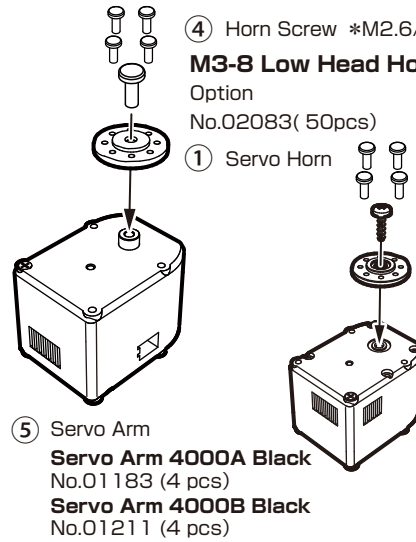

- ④ Horn Screw \*M2.6/M2  
**M3-8 Low Head Horn Screw** (Associated)  
Option  
No.02083( 50pcs)
- ① Servo Horn
- ④ Horn Screw
- ③ Free Horn Screw \*3-10
- ② Free Horn  
**Aluminum Free Horn with Bearing for KRS-4000 series**  
(PCDΦ14-M2- offset 0)  
No.01140 (1 pc)  
No.01141 (6 pcs)
- Free Horn for KRS-4024/4031**  
(PCDΦ14-M2- offset 0)  
No.01158 (1 pc)  
No.01159 (6 pcs)
- ⑤ Servo Arm  
**Servo Arm 4000A Black**  
No.01183 (4 pcs)  
**Servo Arm 4000B Black**  
No.01211 (4 pcs)

## 2500 Series

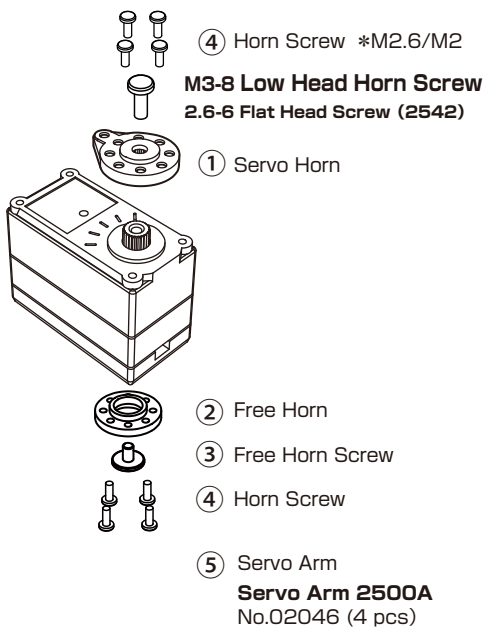

- ④ Horn Screw \*M2.6/M2  
**M3-8 Low Head Horn Screw**  
**2.6-6 Flat Head Screw (2542)**
- ① Servo Horn
- ② Free Horn
- ③ Free Horn Screw
- ④ Horn Screw
- ⑤ Servo Arm  
**Servo Arm 2500A**  
No.02046 (4 pcs)
- ③ **Aluminum Small Diameter Horn**  
(PCDΦ12-M2- offset 0)  
No.02093 (1 pc)  
No.02094 (6 pcs)
- ② **Aluminum Free Horn 2500A**  
(PCDΦ14-M2- offset 0)  
No.02079 (1 pc)  
No.02080 (6 pcs)
- ③ **2.6-6 Flat Head Screw**  
No.01094 (50 pcs)  
**3-6 Flat Head Screw**  
No.02090 (100 pcs)

## 4000/2500 Series

- ① **Aluminum Cramp Horn**  
(PCDΦ17-M2.6- offset +2)  
No.02075 (1 pc)  
No.02076 (6 pcs)
- Aluminum Low height Servo Horn**  
(PCDΦ14-M2- offset 0)  
No.01042 (1 pc)  
No.01043 (6 pcs)
- ② **Low height Servo Horn**  
(PCDΦ14-M2)  
No.01029 (2 pcs)  
No.01030 (12 pcs)  
\*For plastic gear model
- ④ **M2-4 Low Head Screw**  
No.02086 (100 pcs)  
\*Flame t=1mm

## 3300 Series

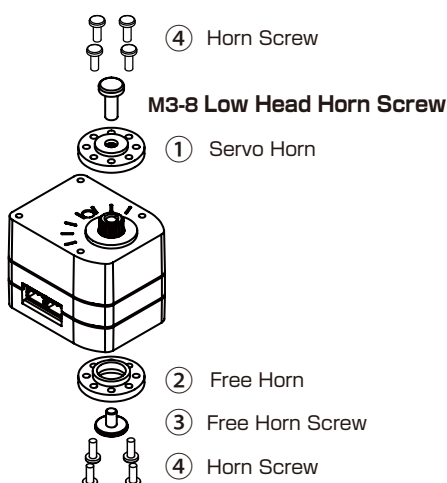

- ④ Horn Screw  
**M3-8 Low Head Horn Screw**
- ① Servo Horn
- ② Free Horn
- ③ Free Horn Screw
- ④ Horn Screw

## 3200 Series

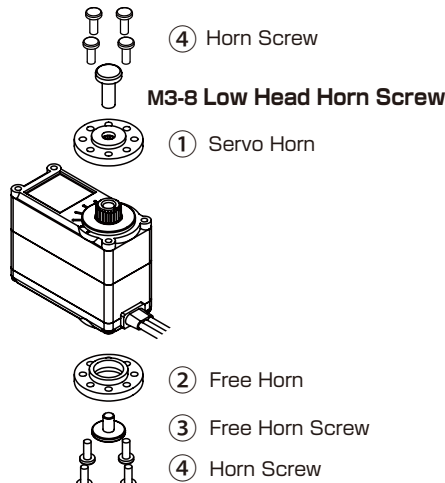

- ④ Horn Screw  
**M3-8 Low Head Horn Screw**
- ① Servo Horn
- ② Free Horn
- ③ Free Horn Screw
- ④ Horn Screw

## 3300/3200 Series

- ① **Small Diameter Horn B**  
(PCDΦ12-M2- offset 0)  
No.02157 (2 pcs)  
No.02158 (12 pcs)
- ② **Small Diameter Horn C**  
(PCDΦ12-M2- offset 0)  
No.02159 (2 pcs)  
No.02160 (12 pcs)
- ③ **2.6-4 Flat Head Tapping Screw**  
No.02164 (100 pcs)
- ④ **M2-4 Low Head Screw**  
No.02086 (100 pcs)  
\*Flame t=1mm

# Communications Standard ICS 3.5

※Refer to the ICS 3.5 Manager/control board manual for further information.

## What is ICS (Interactive Communication System)?

ICS is our unique communications standard for communication between ICS compatible devices, our servos and your PC.

- Previous servo systems have used the PWM signal to control the servo angle. A new standard in signal was introduced to allow for greater fidelity of control. ICS 3.5 also allows for the use of a PWM signal.
- The ICS 3.5 Serial Manager connection software and either an ICS-USB Adapter HS (part number 02043) or a Dual USB Adapter HS (part number 02116) are needed to re-write servo parameters. The software and instruction manuals are available for free download from our website.
- Parameters that can be changed are listed below under the "Description of ICS Menu" heading.
  - ※Use of the old type ICS-USB Adapter (part number 01106) will limit you to a maximum signal speed of 115200bps.
  - ※Connection to an RCB-4HV will allow you to change the ID and the Baud Rate. Please refer to the RCB-4HV manual for further information.

## Description of ICS Menu

- **ID** : Nominate the servo IDs using numbers 0 through 31.  
( Range: 0 ~ 31.)
- **Baudrate** : Choose transmission speeds.  
( Range: 115200, 625000 and 1250000.)
- **MOVE** : Range of movement: Servos rotate output shaft in response to input of serial signal.  
( Range: 3500 (-135° ) to 7500 (0° ) to 11500 (+135° ) )
- **Stretch** : You are able to set the retention property for the servos. The higher the number, the more retention.  
( Range: 1 is the softest and 127 is the hardest. )
- **Stretch settings 1, 2 and 3** : Change between three preset stretch settings when working with a PWM signal. The set value above is always called immediately after turning the servo power on. Changing the stretch presets during operation will result in a change in the characteristics of the movement of the servos.
- **Speed** : Set the servo's maximum output (duty rate). The higher the number, the higher the output and consequently the higher the speed at which it will move.  
( Value range: 1 is the slowest. 127 is the fastest. )
- **Reverse** : Enabling reverse mode will reverse the servo's direction of movement in relation to the input signal.  
( Range: On/Off )
- **Serial signal** : This mode disables the use of PWM signal based movement, and enables the exclusive use of serial signal mode.  
( Range: On/Off )
- **Slave** : Slave mode enables multiple servos using the same ID to move in unison when tethered to a single serial signal.  
( Range: On/Off )
- **Rotation mode** : Rotation mode enables the servos to rotate continuously.  
( Range: On/Off )
- **Punch** : You can set the initial response level of the servo motors. The higher the number, the stronger the initial response to input.  
( Range: 0 is the lowest. 10 is the highest.)
- **Dead band** : You are able to set the dead bandwidth of the servo. The size of the neutral position is determined by this dead bandwidth. The higher the number, the larger the neutral position. The smaller the number, the narrower the neutral position becomes. Setting the dead bandwidth too small can result in slight vibrations (jitter).  
( Range: 0 is the narrowest. 10 is the widest. )
- **Response** : Set how fast the servos respond to input. The smaller the number, the slower the response. The higher the number, the faster the response.  
( Range: 1 is the slowest. 5 is the fastest.)

■ **Damping** : Changing the damping alters the level of braking applied to the servo. A small setting increases the level of braking applied to a rotating servo, slowing it down just before it reaches the position it was moving to. A larger setting reduces this braking effect, but increases the chance of the servo overshooting and rotating further than it meant to.

( Range: 1 is the weakest. 255 is the strongest. )

■ **Protection** : When the servos detect a locked out condition, they will go into protection mode and shut down to save the motors from burning out. This setting sets the amount of time before the servos go into protection mode. The bigger the number, the longer they will wait before going into protection mode.

( Value range: 10 is the shortest. 255 is the longest. )

■ **Limiter (normal rotation)** : You can set the maximum range of movement for normal rotation.

( Value range: Minimum 8000 Maximum 11500.)

■ **Limiter (reverse rotation)** : You can set the maximum range of movement for reverse rotation.

( Value range: Minimum 3500 Maximum 7000.)

■ **Temperature restriction** : This mode enables a limit to be placed on the electrical current. Setting a higher value raises the maximum electrical current threshold. If an electrical current greater than the set threshold is detected, the limiter will come into effect and restrict the current to the maximum set by the user.

( Range: The highest threshold is 1. The lowest threshold is 127.)

■ **Current restriction** : This mode enables a limit to be placed on the electrical current. Setting a higher value raises the maximum electrical current threshold. If an electrical current greater than the set threshold is detected, the limiter will come into effect and restrict the current to the maximum set by the user.

( Range: The lowest current is 1. The highest current is 63.)

■ **User offset** : This enables the user to trim the starting position of the servos.

( Range: From -127 of reverse rotation to 127 of normal rotation.)

■ **Firmware version** : Displays information about the servo firmware. Firmware cannot be updated by the user.

### Initial Parameters

	6003R	4034/3/2	4031	2572	2552R	2542	3204	3304
<b>ID</b>	0	0	0	0	0	0	0	0
<b>RATE</b>	115200	115200	115200	115200	115200	115200	115200	115200
<b>Stretch</b>	60	60	60	60	60	30	100 ※	127
<b>Stretch 1/2/3</b>	60/30/90	60/30/90	60/30/90	60/30/90	60/30/90	30/15/60	60/30/90	60/30/127
<b>Speed</b>	127	127	127	127	127	127	100 ※	127
<b>Reverse</b>	OFF	OFF	OFF	OFF	OFF	OFF	OFF	OFF
<b>Serial signal</b>	ON	ON	ON	ON	ON	ON	OFF	OFF
<b>Slave</b>	OFF	OFF	OFF	OFF	OFF	OFF	OFF	OFF
<b>Rotation mode</b>	OFF	OFF	OFF	OFF	OFF	OFF	OFF	OFF
<b>Punch</b>	1	0	0	0	0	0	0	0
<b>Dead band</b>	1	4	4	2	6	2	2	1
<b>Response</b>	3	3	3	3	3	3	1 ※	1
<b>Damping</b>	128	40	40	12	32	25	25	40
<b>Protection</b>	250	20	20	250	20	250	250	250
<b>Limiter(normal rotation)</b>	11500	11500	11500	11500	11500	11500	11500	11500
<b>Limiter(reverse rotation)</b>	3500	3500	3500	3500	3500	3500	3500	3500
<b>Temperature restriction</b>	30	75	10	10	80	10	40	75
<b>Current restriction</b>	63	40	40	63	20	13	40	40
<b>User offset</b>	0	0	0	0	0	0	0	0
<b>Firmeware version</b>	6	3	3	7	254	254	11	20

(Firmware cannot be updated by the user.)

※Please Use 3204 with below parameters.

Stretch/Speed : Less than 100 Response : Less than 1

# Operation and Connection of Servos

This product can be controlled using either a PWM or serial signal. Use the “Serial Signal” menu function in the ICS manager software to change between a PWM signal and a serial signal. Uncheck the “Serial Signal” box to operate servos using a PWM signal.

## Using a Serial Signal

Multiple servos can be connected to the output of a single control board using the serial signal. You can assign an ID to each servo in a range from 0 to 31 for a total of 32 servos. The signal is then transmitted to these servos based on their ID. The diagram to the right is a representation of this arrangement. Connecting multiple servos to a single line is known as a ‘multi-drop’ or ‘daisy-chain’ arrangement. You can technically assign IDs to up to 32 servos, but daisy-chaining a large number of servos may introduce power supply problems. This also depends on the compatibility of your control board.

**Diagram of a serial signal arrangement**  
(Connected in a daisy-chain arrangement)

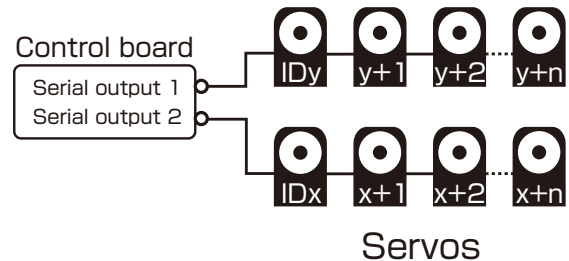

## Serial Signal Compatible Control Board

※The KRS 3000 series servos are designed to be used at a voltage of 6 to 7.4 volts. Please ensure your voltage input to the control board is within this range.

**RCB-4HV** : 2 x serial outputs. Suited for daisy-chaining up to 32 servos.

**RCB-3HV** : Not compatible with daisy-chain arrangements. 24 x serial output ports designed to each connect to one servo for a total of 24 servos.

**KCB-5** : 4 x serial outputs. Up to 10 servos can be controlled per output.

※Use C language for our KCB series servos to allow for greater flexibility of control.

**Dual USB Adapter HS** : This accessory allows you to send commands and control your servos directly from your computer.

## Movement of Servos Using a Serial Signal

■Please refer to the Command Reference for further information.

The command reference is available as a free download from the website below.

<http://kondo-robot.com/>

**Customer center** → **Information Support**

→ **ICS and KRS Servo Development Materials**

## Using a PWM Signal

When operating this product using a PWM signal, position commands can be made using general radio control signals. Functionality can also be expanded by using other specific signals.

PWM cycle compatibility : 3ms ~ 30ms  
 Pulse width: Normal operation 700 $\mu$ s to 2300 $\mu$ s.  
 Expanded function 50 $\mu$ s to 200 $\mu$ s.

### ■ Controlling Servos with a Control Board

Only one servo per output port may be connected when using a PWM signal. Uncheck the "Serial Signal" check box.

### ■ Control Using Programming

Please refer to "When using a PWM signal" in the ICS 3.5 Command Reference to control the servos in PWM mode.

Example of how servos are connected in PWM control mode.

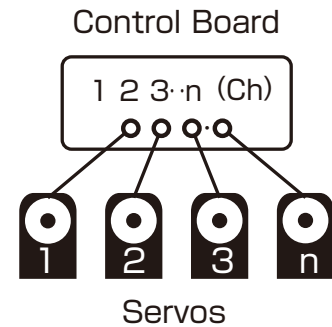

## PWM Compatible Control Boards

※The KRS 3000 series is designed to be operated between 6.0 and 7.4 volts. Ensure the input current is within that range.

**RCB-3HV** : RCB-3HV/RCB-3J: 24 x PWM outputs. Up to 24 servos can be connected. Suitable for teaching and changing characteristics.

**KCB-5** : 6 x PWM outputs. Teaching and characteristic change are possible depending on the programming. (Cannot be used in conjunction with serial terminal, so separate wiring is required.)

## Movement of Servos Using a PWM Signal

### ■ Position Command (MOVE)

The output shaft of the servo rotates in accordance with the PWM input signal.  
 700 $\mu$ s (-135°) to 1500 $\mu$ s (0°) to 2300 $\mu$ s (+135°)

was in directly before they were instructed to change position.

Preset parameters (SET1, SET2 and SET3) can be changed using the ICS menu. Setting 1 (SET1) will automatically be selected when turning the servo power on. .

Stretch 1 (SET1) 100 $\mu$ s +/-10 $\mu$ s  
 Stretch 2 (SET2) 150 $\mu$ s +/-10 $\mu$ s  
 Stretch 3 (SET3) 200 $\mu$ s +/-10 $\mu$ s

### ■ Power Limitation

Inputting a pulse width of 50 $\mu$ s will reduce the power output of the servos. This state of limited power output will be maintained until the servos receive the next position command with a pulse width between 700 $\mu$ s and 2300 $\mu$ s.

### ■ Characteristic Change (Stretch preset change)

Inputting a pulse width of 100 $\mu$ s, 150 $\mu$ s or 200 $\mu$ s will instruct the servos to change between three preset characteristics (SET1 ~ SET3 stretch settings) saved within the servo. The servos will maintain the state the output shaft

### ■ Position Capture (Teaching)

Inputting a pulse width of between 50 $\mu$ s and 200 $\mu$ s will instruct the servos to output a pulse width that indicates the current position of the servo output shaft. This pulse output from the servos is then read by the control board and the current position of the servos can be ascertained.

### ■ Diagram showing the timing of the signal and servo movement ■

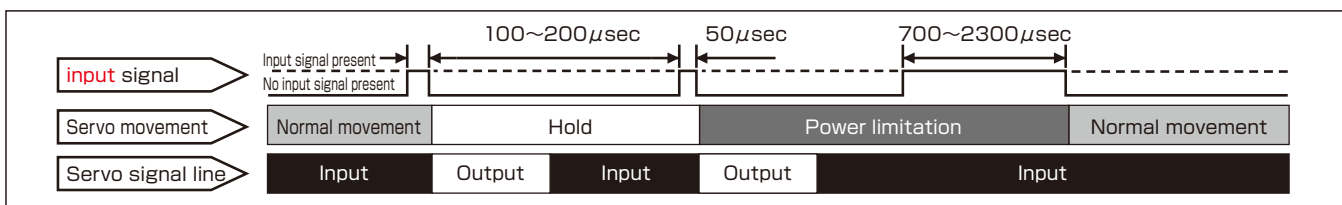

## Points of Caution When Using a PWM Signal

※Voltage drops and/or noise in the signal may cause unintentional movement during operation. Use this product with caution.

※Using the position capture (teaching) function in conjunction with a home-made control board requires "pull-up resistor" in the signal wire from the control board CPU. Furthermore, the CPU servo control board needs to be able to change between signal input and output. Kondo control boards are compatible with the position capture function.

# Optional Extras and Related Products

\*See our website for further information.

## Cases \*See our website for availability of cases and/or gears for repair/spares.

Change the bottom casing on the 6000 series servos to make it easy to adapt this servo to your project needs.

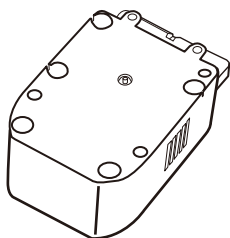

**Flat Bottom Case for KRS-6000HV series**  
No.02023  
No.02024(6 pcs)

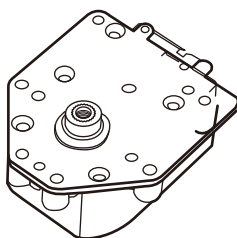

**Bottom Case with Flange and Axis for KRS-6000HV series**  
No.02025  
No.02026(6 pcs)

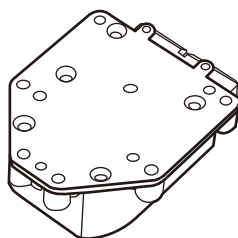

**Flange Flat Bottom Case for KRS-6000HV series**  
No.02027  
No.02028(6 pcs)

**Bottom Case for double Servo for KRS-6000HV series**  
No.02029  
No.02030(6 pcs)

You can easily join two servos in a back to back arrangement by using our "flat flange bottom case". These are available in a set known as the "double servo bottom case". Two flat flange bottom cases and the required screws are available as a set.

※Three M2.6 x 35 screws and one single M2.6 x 25 screw are used to secure the casing. When reinstalling the screws, please be sure to screw them in to the correct locations as they are different lengths.

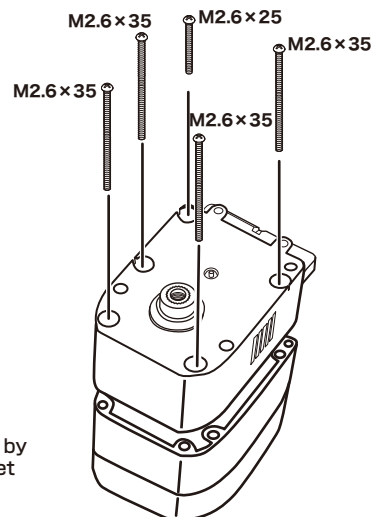

## Spacers and Arm Supporters

\*A more stable movement can be created through the use of a spacer or an arm supporter in between the horn and the frame.

**Spacer Horn A**  
for 4000 series  
No.01224 (4 pcs)

**Friction Spacer 4000A**  
for 4000 series  
No.01197 (4 pcs)

**Arm Supporter 4000A**  
for 4000 series  
No.01195 (2 pcs)

**Servo Spacer 4000A**  
for 4000 series  
No.01223 (4 pcs)

**Extension Adapter A**  
for 4000 series  
No.01204 (2 pcs)

**Arm Supporter 2500A**  
for 2500 series  
No.02052 (2 pcs)

## Electronics

\*A wide range of machines can be developed to meet various objectives by using a combination of our control boards, sensors and communication devices.

\*Also Help to prevent wires damage in between Frames and the horn.

### Control Board

**RCB-4HV only Board** with Heart To Heart 4  
No.03076 (1 pc)

**RCB-3HV only Board** with Heart To Heart 3  
No.03027 (1 pc)

**KCB-5**  
Programmable C  
No.03081 (1 pc)

**KCB-4WL**  
with WiFi  
No.03078 (1 pc)

### Sensor

**RAS-2C**  
G sensor (Accelerometer)  
No.03045 (1 pc)

**KRG-4**  
Gyro sensor  
No.03003 (1 pc)

### Communication

**Dual USB Adapter HS**  
for PC Link with USB  
No.02116 (1 pc)

**KBT-1**  
Bluetooth module  
No.03062 (1 pc)

**KRC-5FH**  
2.4GHz FHSS Tx/Rx set  
No.03099 (1 pc)

# Troubleshooting

---

## ■ Servos do not respond to a serial signal.

- The ID or the Baud Rate may be incorrect.  
Always set the ID as 0 and the RATE as 115200 when connecting an RCB-3HV control board.

## ■ Servos do not respond to a PWM signal.

- The PWM signal may be incompatible.  
This product is designed for use in robotics equipment, and may not be compatible with some radio controlled receivers.
- "Serial Signal" is checked.

## ■ Servos lose power during operation.

- The temperature limiter may have triggered to prevent overheating.  
Switch the power off and wait for the servos to cool down. Then re-start and check for full power. You can change the threshold at which servos go into temperature limitation mode through the ICS menu. However, lowering this value (and consequently raising the temperature threshold) increases the possibility of a servo failure.
- Servo movement mode may have been changed during serial operation.  
Sharp drops in voltage can cause the servos to change between serial and PWM modes. Switching the power off and then on again will return the servos to the correct mode. When operating servos in serial mode, please ensure you have selected "Serial Signal" as "on" in the ICS menu. This isn't really a problem when operating using PWM movement.

## ■ Servos move erratically.

- The serial movement baud rate may be unsupported.  
Servos may move erratically when they receive a signal baud rate that is not supported.
- Servos that were assigned the same ID may be connected in a daisy-chain.  
Daisy-chaining servos assigned the same ID on the same output line will result in problems with the signal and erratic servo movement. To control servos of the same ID on a single signal, set one as a master servo and the rest as slave servos through the ICS menu.
- The received signal may be incompatible with the movement mode.  
Inputting incompatible signals when using serial or PWM movement modes can result in erratic movement of servos.
- There may be a faulty connection or broken wire.  
Part of the wiring to the servos may be frayed or severed and coming in and out of contact.

## ■ Diminished servo power.

- Servos may have detected a locked out condition and have gone into protection mode.  
If the servos are indeed locked out, extricate them from that position and remove the load from the servos. You can set the time threshold the servos will wait before going into protection mode via the ICS menu.

## ■ A chemical-like smell is being emitted from the servos during operation.

- The motor coils may be starting to burn out.  
Immediately turn off the power and allow the servos to cool before operating again.