



application
INFO
available

UCC19411/2/3
UCC29411/2/3
UCC39411/2/3
PRELIMINARY

Low Power Synchronous Boost Converter

FEATURES

- 1V Input Voltage Operation Start-up Guaranteed under FULL Load on Main Output, and Operation Down to 0.5V
- 200mW Output Power at Battery Voltages as low as 0.8V
- Secondary 7V Supply from a Single Inductor
- Output Fully Disconnected in Shutdown
- Adaptive Current Mode Control for Optimum Efficiency
- High Efficiency over Wide Operating Range
- 6µA Shutdown Supply Current
- Output Reset Function with Programmable Reset Period

DESCRIPTION

The UCC39411 family of low input voltage, single inductor boost converters is optimized to operate from a single or dual alkaline cell, and steps up to a 3.3V, 5V, or adjustable output at 200mW. The UCC39411 family also provides an auxiliary 7V output, primarily for the gate drive supply, which can be used for applications requiring an auxiliary output, such as 5V, by linear regulating. The primary output will start up under full load at input voltages typically as low as 0.8V with a guaranteed max of 1V, and will operate down to 0.5V once the converter is operating, maximizing battery utilization.

The UCC39411 family is designed to accommodate demanding applications such as pagers and cell phones that require high efficiency over a wide operating range of several milli-watts to a couple of hundred milli-watts. High efficiency at low output current is achieved by optimizing switching and conduction losses with a low total quiescent current (50µA). At higher output current the 0.5Ω switch, and 1.2Ω synchronous rectifier along with continuous mode conduction provide high power efficiency. The wide input voltage range of the UCC39411 family can accommodate other power sources such as NiCd and NimH.

The 39411 family also provides shutdown control. Packages available are the 8 pin SOIC (D), 8 pin DIP (N or J), and 8 pin TSSOP (PW) to optimize board space.

SIMPIFIED BLOCK DIAGRAM AND APPLICATION CIRCUIT (UCC39412)

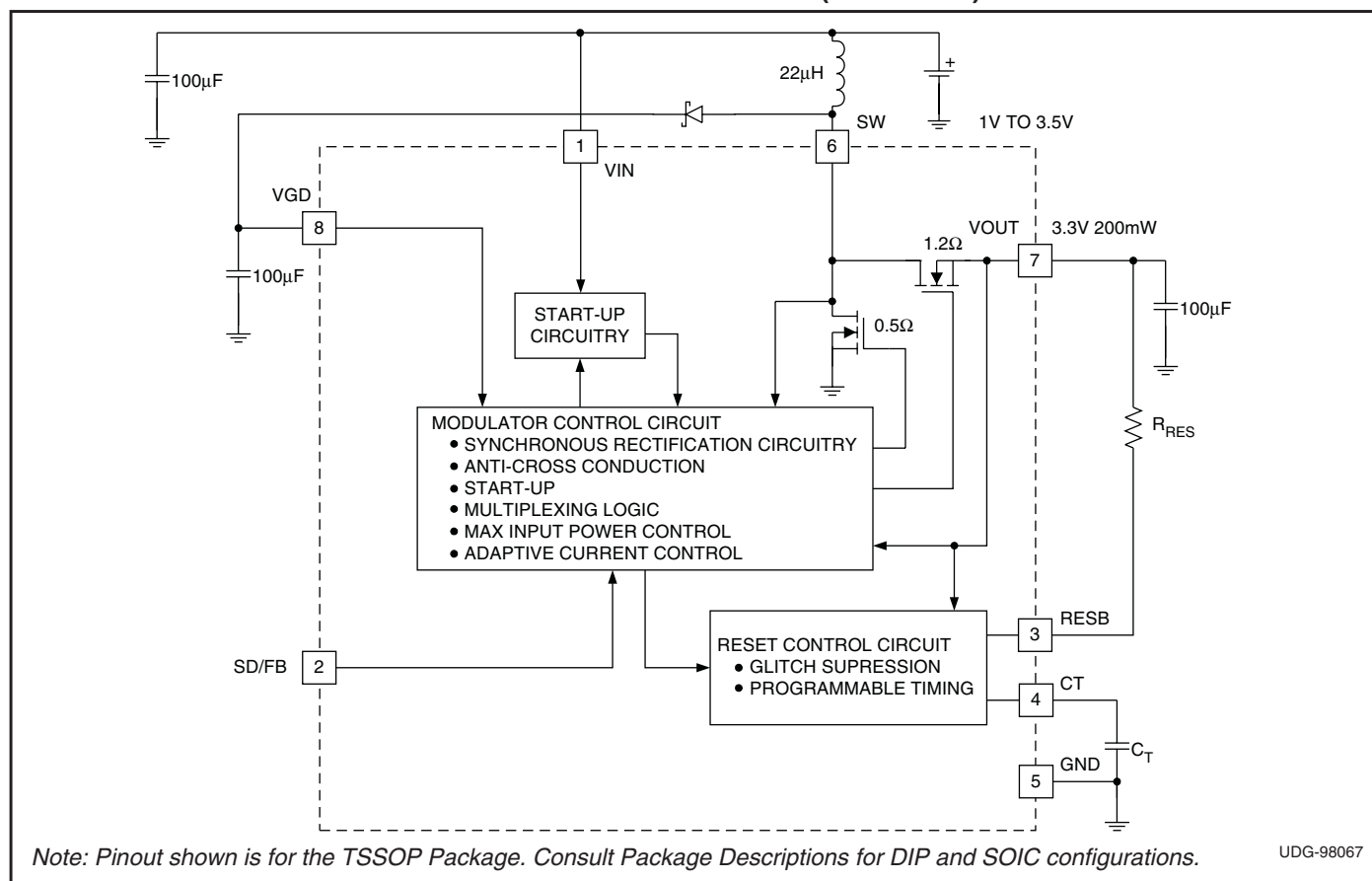

UDG-98067

ABSOLUTE MAXIMUM RATINGS

VIN Voltage	-0.3V to 10V
SD Voltage	-0.3V to VIN
VGD Voltage	-0.3V to 14V
SW Voltage	-0.3V to 15V

Currents are positive into, negative out of the specific terminal. Consult Packaging Section of the Databook for thermal limitations and considerations of packages.

CONNECTION DIAGRAMS

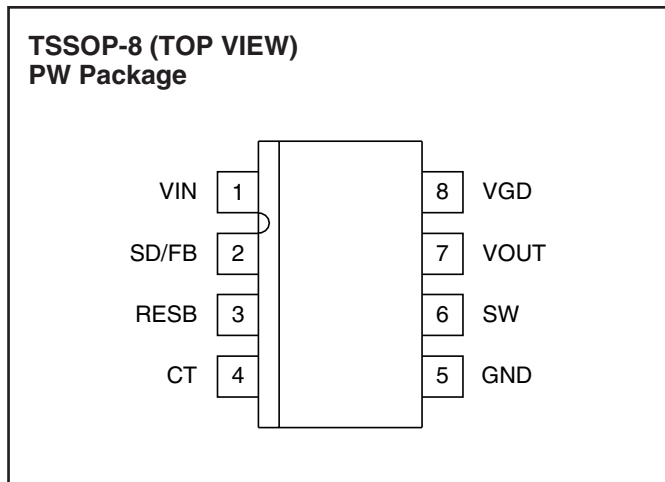
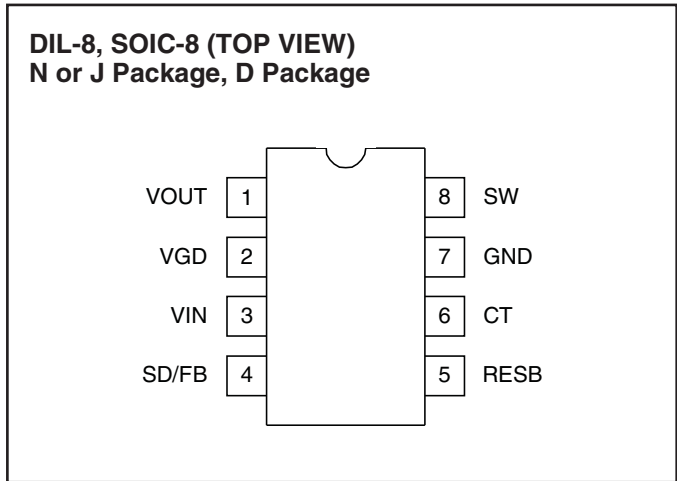

ELECTRICAL CHARACTERISTICS: T_J = 0°C to +70°C for the UCC39411/2/3, T_J = -40°C to +85°C for the UCC29411/2/3, T_J = -55°C to +125°C for the UCC19411/2/3, V_{IN} = 1.25V for UCC39411/2, V_{IN} = 2.5V for the UCC39413, T_A = T_J.

PARAMETER	TEST CONDITIONS	UCC39411 UCC39412 UCC39413			UCC19411/2/3 UCC29411/2/3			UNITS
		MIN	TYP	MAX	MIN	TYP	MAX	
VIN Section								
Minimum Start-up Voltage	No External VGD Load, T _J = 25°C, I _{OUT} = 60mA (Note 1)		0.8	1		.08	1	V
	No External VGD Load, I _{OUT} = 60mA (Note 1)		0.9	1.1		1.2	1.4	V
Minimum Dropout Voltage	No External VGD Load, I _{OUT} = 10mA (Note 1)			0.5			0.7	V
Input Voltage Range		1.1		3.2	1.3		3.2	V
Quiescent Supply Current	(Note 2)		6	12		8	16	μA
Supply Current at Shutdown	SD = GND		6	12		8	16	μA

ELECTRICAL CHARACTERISTICS: $T_J = 0^\circ\text{C}$ to $+70^\circ\text{C}$ for the UCC39411/2/3, $T_J = -40^\circ\text{C}$ to $+85^\circ\text{C}$ for the UCC29411/2/3, $T_J = -55^\circ\text{C}$ to $+125^\circ\text{C}$ for the UCC19411/2/3, $V_{IN} = 1.25\text{V}$ for UCC39411/2, $V_{IN} = 2.5\text{V}$ for the UCC39413, $T_A = T_J$.

PARAMETER	TEST CONDITIONS	UCC39411 UCC39412 UCC39413			UCC19411/2/3 UCC29411/2/3			UNITS
		MIN	TYP	MAX	MIN	TYP	MAX	
Output Section								
Quiescent Supply Current	(Note 2)		15	28		20	37	μA
Supply Current at Shutdown	SD = GND		3	6		5	10	μA
Regulation Voltage (UCC39412)	$1\text{V} < V_{IN} < 3\text{V}$	3.2	3.3	3.39	3.15	3.3	3.45	V
	$1\text{V} < V_{IN} < 3\text{V}$, $0\text{mA} < I_{OUT} < 60\text{mA}$ (Note 1)	3.17	3.3	3.43	3.11	3.3	3.5	V
Regulation Voltage (UCC39413)	$1\text{V} < V_{IN} < 5\text{V}$	4.85	5	5.15	4.78	5	5.23	V
	$1\text{V} < V_{IN} < 5\text{V}$, $0\text{mA} < I_{OUT} < 60\text{mA}$ (Note 1)	4.8	5	5.2	4.71	5	5.3	V
ADJ Voltage (UCC39411)	$1\text{V} < V_{IN} < 3\text{V}$	1.212	1.25	1.288	1.194	1.25	1.306	V
VGD Output Section								
Quiescent Supply Current	(Note 2)		20	40		27	55	μA
Supply Current at Shutdown	SD = GND		20	40		27	55	μA
Regulation Voltage (UCC39411/2)	$1\text{V} < V_{IN} < 3\text{V}$	6.3	7	7.7	6.3	7	7.7	V
	$1\text{V} < V_{IN} < 3\text{V}$, $0\text{mA} < I_{OUT} < 10\text{mA}$ (Note 1)	6.3	7	7.7	6.3	7	7.7	V
Regulation Voltage (UCC39413)	$1\text{V} < V_{IN} < 5\text{V}$	7.7	8.5	9.3	7.7	8.5	9.3	V
	$1\text{V} < V_{IN} < 5\text{V}$, $0\text{mA} < I_{OUT} < 10\text{mA}$ (Note 1)	7.7	8.5	9.3	7.7	8.5	9.3	V
Inductor Charging Section (L=22μH)								
Peak Discontinuous Current	Operating Range, L=22.1 μH	180	250	300	180	250	300	mA
Peak Continuous Current		385	550	715	385	550	715	mA
Charge Switch $R_{DS(ON)}$	D Package		0.5	0.75		0.6	0.85	Ω
Current Limit Delay	(Note 1)		50			50		ns
Synchronous Rectifier Section								
Rectifier $R_{DS(ON)}$	D Package		1.2	1.8		1.4	2.16	Ω
Shutdown Section								
Threshold		0.4	0.6	0.8	0.2	0.6	0.9	V
Input Bias Current	SD = GND	2	5	15	2	5	15	μA
	SD = 1.25V		5	20		20	100	nA
Reset Section								
Threshold (UCC39411)		1.08	1.125	1.17	1.07	1.125	1.18	V
Threshold (UCC39412)		2.85	2.97	3.09	2.83	2.97	3.11	V
Threshold (UCC39413)		4.32	4.5	4.68	4.3	4.5	4.7	V
Reset Period	$C_T = 0.15\mu\text{F}$	113	188	263	94	188	282	ms
V_{OUT} to Reset Delay	V_{OUT} Falling at $-1\text{mV}/\mu\text{s}$ (Note 1)		60			60		μs
Sink Current		1	20		1	20		mA
Output Low Voltage	$I_{OUT} = 500\mu\text{A}$			0.1			0.1	V
Output Leakage				0.5			0.5	μA

Note 1 : Guaranteed by design and alternate test methods. Not 100% tested in production.

Note 2: For the UCC39411 $V_{FB} = 1.306\text{V}$, $V_{GD} = 7.7\text{V}$, For the UCC39412 $V_{OUT} = 3.5\text{V}$ and $V_{GD} = 7.7\text{V}$, For the UCC39413 $V_{OUT} = 5.3\text{V}$, $V_{GD} = 9.3\text{V}$.

PIN DESCRIPTIONS

VIN: Input Voltage to supply the IC during start-up. After the output is running the IC draws power from VOUT or VGD.

SW: An inductor is connected between this node and VIN. The VGD (Gate Drive Supply) flyback diode is also connected to this pin. When servicing the main output supply this pin will pull low charging the inductor, then shut off dumping the energy through the synchronous rectifier to the output. When servicing the VGD supply the internal synchronous rectifier stays off and the energy is diverted to VGD through the flyback diode. During discontinuous portions of the inductor current, a MOSFET resistively connects VIN to SW damping excess circulating energy to eliminate undesired high frequency ringing.

VGD: The VGD pin which is coarsely regulated around 7V (8.5V for the UCC39413) is primarily used for the gate drive supply for the power switches in the IC. This pin can be loaded with up to 10mA as long as it does not present a load at voltages below 2V (this ensures proper start-up of the IC). The VGD supply can go as low as

6.3V without interfering with the servicing of the main output. Below 6.3V, VGD will have the highest priority.

VOUT: Main output voltage (3.3V, 5V, or adjustable) which has highest priority in the multiplexing scheme, as long as VGD is above the critical level of 6.3V. Startup at full load is achievable at input voltages down to 1V.

CT: This pin provides the timer for determining the reset period. The period is controlled by placing a capacitor to ground of value $C = (0.81e^{-6}) \cdot T$ where T is the desired reset period.

RESB: This pin provides an active low signal to alert the user when the main output voltage falls below 10% of its targeted value. The open drain output can be used to reset a microcontroller which may be powered off of the main output voltage.

SD/FB: For the UCC39411, this pin is used to adjust the output voltage via a resistive divider from VOUT. It also serves as the shutdown pin for all three versions. Pulling this pin low provides a shutdown signal to the IC.

GND: Ground of the IC.

APPLICATION INFORMATION

Operation

A detailed block diagram of the UCC39411 is shown in Figure 1. Unique control circuitry provides high efficiency power conversion for both light and heavy loads by transitioning between discontinuous and continuous conduction based on load conditions. Figure 2 depicts converter waveforms for the application circuit shown in Figure 3. A single 22μH inductor provides the energy pulses required for a highly efficient 3.3V converter at up to 200mW output power

At time t1 the 3.3V output voltage has dropped below its lower threshold, and the inductor is charged with an on time determined by: $T_{ON} = 5.5\mu s/VIN$. For a 1.25V input and a 22μH inductor, the resulting peak current is approximately 250mA. At time t2, the inductor begins to discharge with a minimum off time of approximately 1μs. Under lightly loaded conditions, the amount of energy delivered in this single pulse would satisfy the voltage control loop, and the converter would not command any more energy pulses until the output again drops below the lower voltage threshold

At time t3 the VGD supply drops below its lower threshold, but the output voltage is still above its threshold point. This results in an energy pulse to the gate drive supply at t4. In some cases, a single pulse supplied to

VGD is insufficient to raise the VGD voltage level enough to satisfy the voltage loop. Under this condition, multiple pulses will be supplied to VGD. Note: when the UCC39411/2/3 is servicing VGD only, the IC will maintain a discontinuous mode of operation. After time t4, the 3.3V output drops below its threshold and requests to be serviced once the VGD cycle has completed, which occurs at time t5.

Time t6 represents a transition between light load and heavy load. A single energy pulse is not sufficient to force the output voltage above its upper threshold before the minimum off time has expired and a second charge cycle is commanded. Since the inductor current does not reach zero in this case, the peak current is greater than 250mA at the end of the next charge on time. The result is a ratcheting of inductor current until either the output voltage is satisfied, or the converter reaches its set current limit. At time t7, the gate drive voltage has dropped below its 7V threshold but the converter continues to service the output because it has higher priority unless VGD drops below $\approx 6.3V$

Between time t7 and t8, the converter reaches its peak current limit.

Once the peak current is reached, the converter operates in continuous mode with approximately 60mA of in-

APPLICATION INFORMATION (continued)

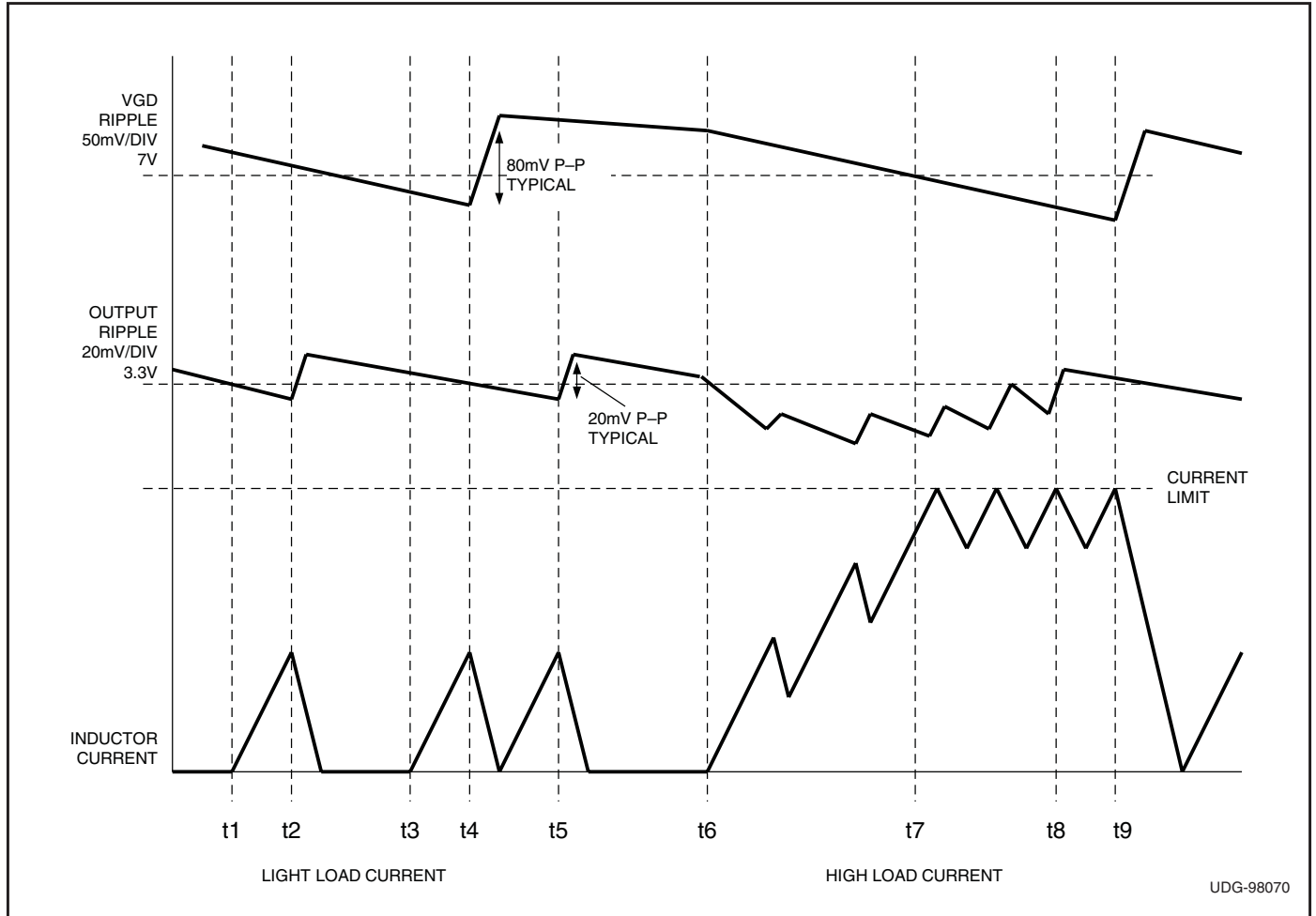
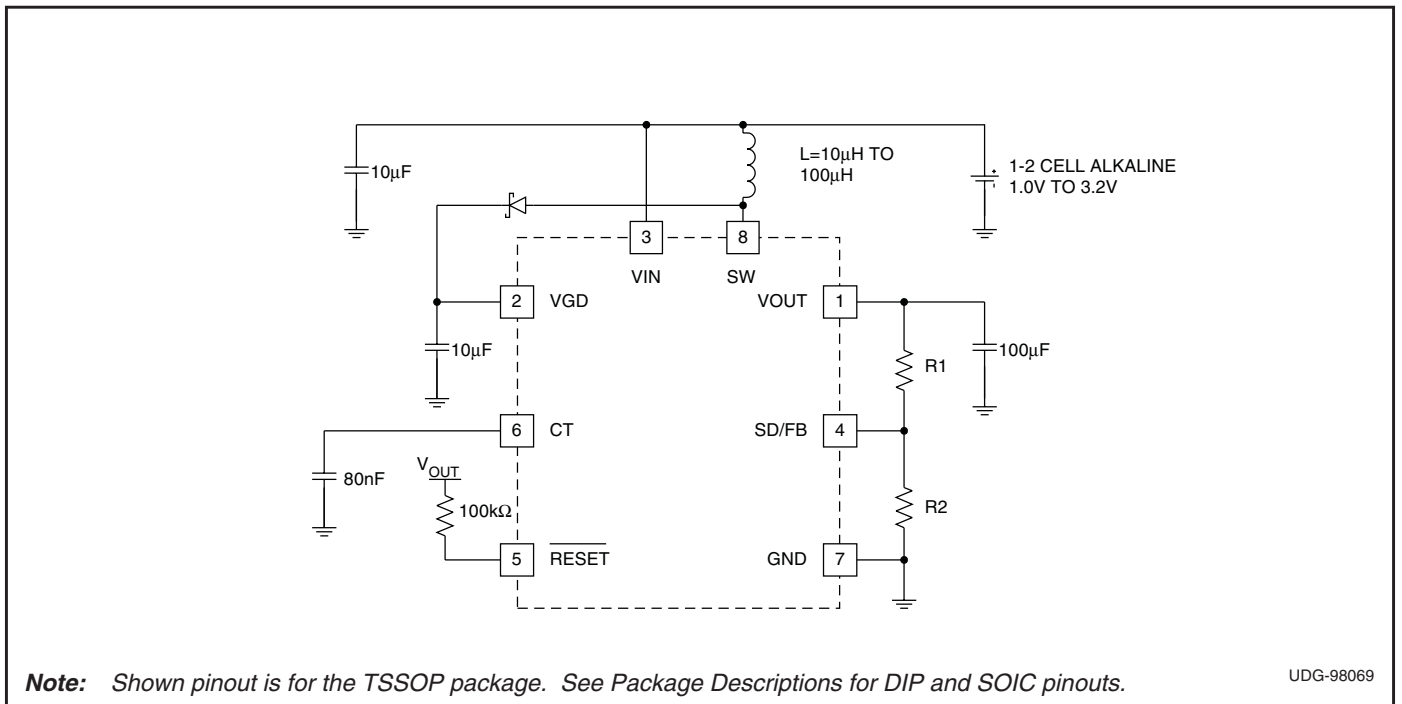

Figure 2. Inductor current and output ripple waveforms.



Note: Shown pinout is for the TSSOP package. See Package Descriptions for DIP and SOIC pinouts.

Figure 3. Low power synchronous boost converter ADJ version -200mW.

APPLICATION INFORMATION (continued)

ductor current ripple. At time t8, the 3.3V output is satisfied and the converter can service the gate drive voltage, VGD, which occurs at time t9

Shutdown Control

Shutdown of the UCC39411/2/3 is controlled via interface with the SD/FB pin. Pulling the SD/FB pin low, for all versions, causes the IC to go into shutdown. In the UCC39412/3, the SD/FB pin is used solely as a shutdown function. Therefore, the SD/FB pin for the UCC39412 and UCC39413 can be directly controlled using conventional CMOS or TTL technology. For the UCC39411, interface into the SD/FB is slightly more complicated due to the added feedback function. When feeding back the output voltage to the SD/FB pin on the UCC39411, the IC requires a thevenin impedance of at least 200kΩ (500kΩ for industrial/military applications) to ground. Then, to accomplish shutdown of the IC, an open drain device may be used.

Component Selection Inductor Selection

An inductor value of 22μH will work well in most applications, but values between 10μH to 100μH are also acceptable. Lower value inductors typically offer lower ESR and smaller physical size. Due to the nature of the “bang-bang” controllers, larger inductor values will typically result in larger overall voltage ripple, because once the output voltage level is satisfied the converter goes discontinuous, resulting in the residual energy of the inductor causing overshoot.

It is recommended to keep the ESR of the inductor below 0.15Ω for 200mW applications. A Coilcraft DT3316P-223 surface mount inductor is one choice since it has a current rating of 1.5A and an ESR of 84mΩ.

Other choices for surface mount inductors are shown in Table 1.

MANUFACTURER	PART NUMBERS
Coilcraft Cary, Illinois Tel: 708-639-2361 Fax: 708-639-1469	DT Series
Coiltronics Boca Raton, Florida Tel: 407-241-7876	CTX Series

Table 1. Inductor Suppliers

Output Capacitor Selection

Once the inductor value is selected the capacitor value will determine the ripple of the converter. The worst case peak to peak ripple of a cycle is determined by two components, one is due to the charge storage characteristic, and the other is the ESR of the capacitor. The worst case ripple occurs when the inductor is operating at max current and is expressed as follows:

$$\Delta V = \frac{(I_{CL})^2 L}{2C(V_O - V_I)} + I_{CL} C_{ESR}$$

- I_{CL} = the peak inductor current = 550mA
- ΔV = Output ripple
- V_O = Output Voltage
- V_I = Input Voltage
- C_{ESR} = ESR of the output capacitor.

A Sanyo OS-CON series surface mount capacitor (10SN100M) is one recommendation. This part has an ESR rating of 90mΩ at 100μF.

Other potential capacitor sources are shown in Table 2.

MANUFACTURER	PART NUMBER
Sanyo Video Components San Diego, California Tel: 619-661-6322 Fax: 619-661-1055	OS-CON Series
AVX Sanford, Maine Tel: 207-282-5111 Fax: 207-283-1941	TPS Series
Sprague Concord, New Hampshire Tel: 603-224-1961	695D Series

Table 2. Capacitor Suppliers

Input Capacitor Selection

Since the UCC39411 family does not require a large decoupling capacitor on the input voltage to operate properly, a 10μF cap is sufficient for most applications. Optimum efficiency will occur when the capacitor value is large enough to decouple the source impedance, this usually occurs for capacitor values in excess of 100μF.

TYPICAL CHARACTERISTICS

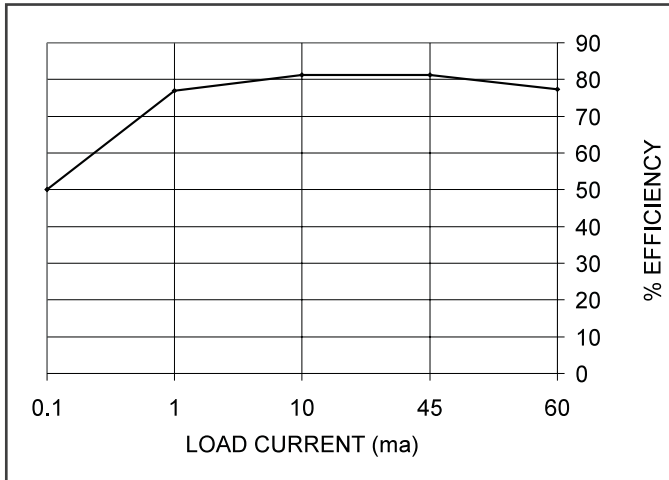

Figure 4. Percent Efficiency at $V_{IN} = 1.0$, $V_{OUT} = 3.3V$

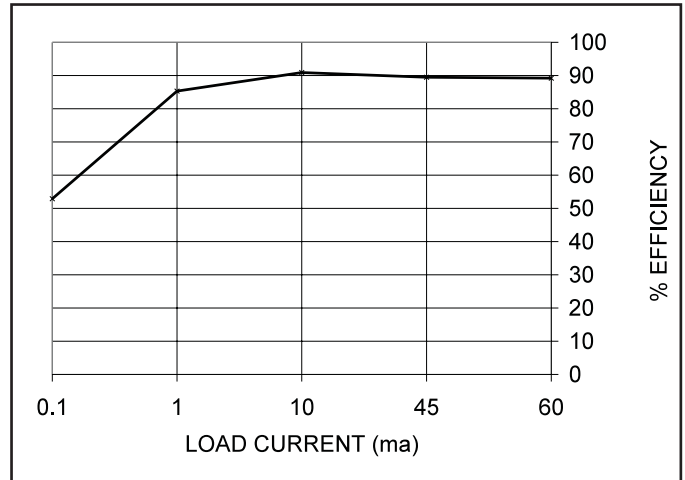

Figure 6. Percent Efficiency at $V_{IN} = 2.5$, $V_{OUT} = 3.3V$

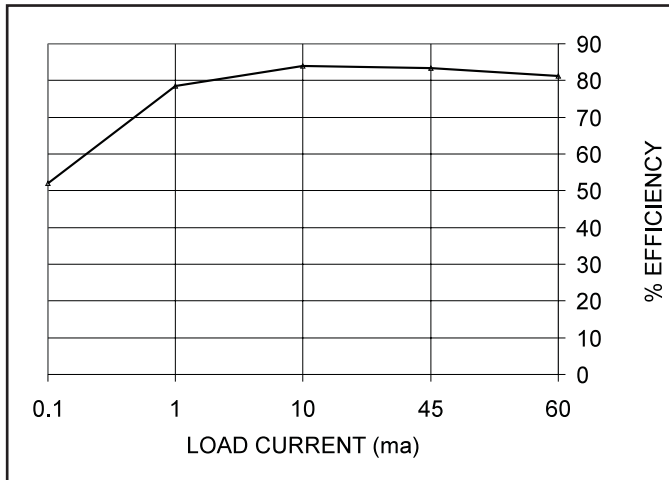

Figure 5. Percent Efficiency at $V_{IN} = 1.25$, $V_{OUT} = 3.3V$

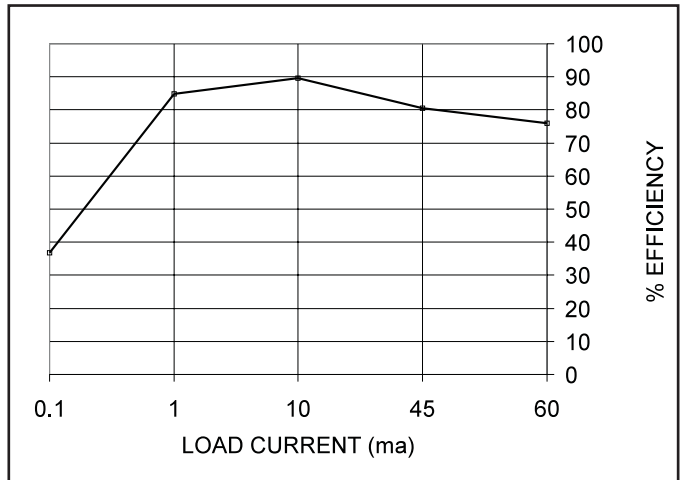

Figure 7. Percent Efficiency at $V_{IN} = 3.3$, $V_{OUT} = 3.3V$