

**ER-150**

**SAMSUNG**

---

**ELECTRONIC CASH REGISTER**

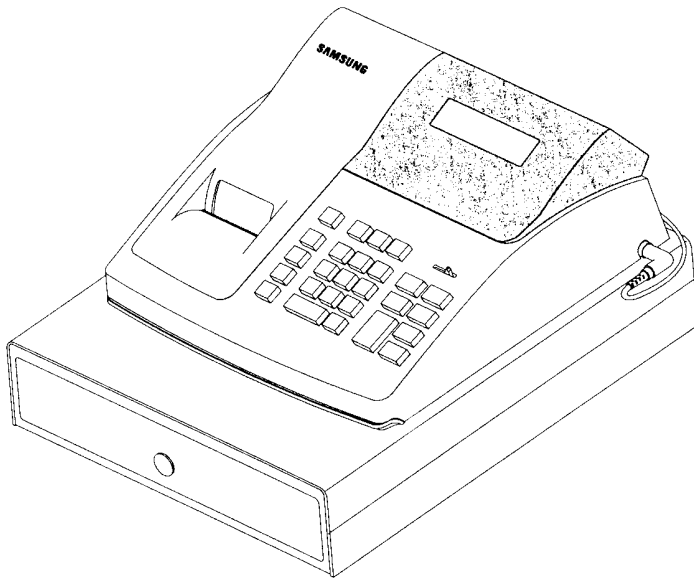

**OPERATION MANUAL**

All specifications are object to change without notice.



## **SAFETY NOTICE**

The socket-outlet shall be installed near the equipment and shall be easily accessible.

## **P/Z MODE SIGN ON CODE PROGRAMMING**

The ER-150 has the added feature of an extra security function to limit access to certain phases of operation.

Through optional programming, you may require a four digit code before allowing access to the **Z** and **P** Programming modes.

When the mode switch is changed to a protected mode, the buzzer sounds until the switch is returned to an unprotected mode. If no mode protection is required then you may disregard this section.

---

## TO ESTABLISH OR CHANGE THE SECRET CODE

1. Switch the mode lock to the "X" position, press No Sale(#/NS), enter the four digit code,
  - press the **RA** key for **Z** mode protection.
  - press the **PO** key for **P** mode protection.

### ESTABLISHES CODE FOR Z MODE

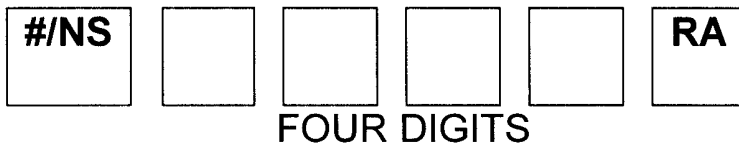

### ESTABLISHES CODE FOR P MODE

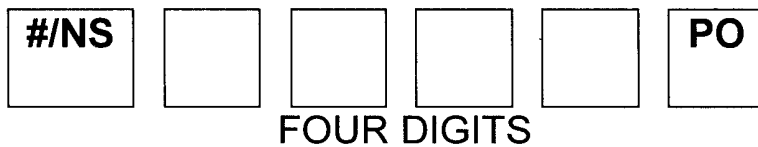

NOTE : THE FOUR DIGIT CODE PROTECTION  
CAN BE DISABLED BY ENTERING BEFORE  
ZERO'S AS THE CODE NUMBER USING THE  
SAME SEQUENCE AS ABOVE.

2. To enter the **Z** or **P** modes once protection is established, place the mode switch in the "X" position and press the (-) minus key, enter your four digit code and press the % discount key.
-

# TABLE OF CONTENTS

<b>INITIAL SET UP INSTRUCTIONS</b>	<b>1</b>
UNPACK THE CASH REGISTER .....	1
INSTALL AND REPLACE BATTERIES .....	1
CLEAR RANDOM ACCESS MEMORY (RAM) AND INITIALIZE CASH REGISTER .....	2
LOAD PAPER .....	2
HOW TO REPLACE THE INK ROLLER .....	3
<b>FEATURES</b>	<b>4</b>
MODE SWITCH .....	4
DISPLAY .....	4
KEYBOARD .....	5
KEY FUNCTIONS .....	5
<b>PROGRAMMING</b>	<b>7</b>
TAX, DECIMAL POINT INFORMATION .....	7
DEPARTMENT STATUS .....	7
TAX RATE.....	8
SETTING THE PERCENT (%) KEY .....	8
SETTING THE MACHINE NUMBER .....	8
RECEIPT PRINT / JOURNAL PRINT .....	9
ROUNDING OPTION .....	9
SYSTEM OPTIONS .....	10
OPTION 1 .....	10
OPTION 2 .....	10
<b>SETTING THE DATE</b>	<b>11</b>
<b>REGISTER MODE OPERATIONS</b>	<b>11</b>
NO SALE OPERATIONS .....	12
NON ADD NUMBER ENTRIES .....	12
DEPARTMENT OPERATION .....	13
MULTIPLE ITEM DEPARTMENT ENTRY .....	13

---

SINGLE ITEM DEPARTMENT SALES .....	13
MINUS (-) KEY OPERATION .....	14
MULTIPLE MINUS OPERATION .....	14
MINUS SINGLE OPERATION .....	14
PERCENT DISCOUNT OPERATION .....	15
PERCENT DISCOUNT ON ITEM .....	15
PERCENT DISCOUNT ON ENTIRE SALE .....	15
MERCHANDISE RETURN OPERATION .....	16
VOID OPERATION .....	16
LAST ITEM VOID / ERROR CORRECT .....	16
PREVIOUS ITEM VOID .....	17
TENDERING OPERATION .....	17
CASH TENDER .....	17
AMOUNT TENDERED ON CASH .....	17
CHARGE TENDER .....	18
SPLIT TENDER .....	18
RECEIVED ON ACCOUNT (RA) OPERATION .....	18
PAID OUT (PO) OPERATION .....	18
<b>MANAGEMENT REPORTS AND BALANCING</b> .....	<b>19</b>
CASH IN DRAWER DECLARATION .....	19
FINANCIAL DAILY REPORT .....	20
P-T-D GRAND TOTAL REPORT .....	20
SYSTEM BALANCING .....	21
<b>MAINTENANCE</b> .....	<b>21</b>
<b>SPECIFICATIONS</b> .....	<b>22</b>
DIMENSIONS .....	22
DRAWER .....	22
MODE KEY .....	22
KEYBOARD .....	22
PRINTER .....	22
DISPLAY .....	22
POWER .....	22

---

# INITIAL SET UP INSTRUCTIONS

The following instructions describe how to unpack and start up the cash register.

---

## UNPACK THE CASH REGISTER

1. Unpack and unwrap cash register.
2. Locate in the packing the following items.
  - \* 1 roll of paper
  - \* 1 rewind spindle (for journal tape)
  - \* 2 batteries
  - \* 1 battery cover

---

## INSTALL AND REPLACE BATTERIES

1. Open printer cover and position batteries make sure that the positive and negative poles are aligned correctly.
2. Stick a sheet of battery cover.

**NOTE :** This register comes with 2 "AAM" batteries for providing memory back-up in a power interruption. In order to assure continuous battery back-up protection, it is important that batteries be changed once a year.

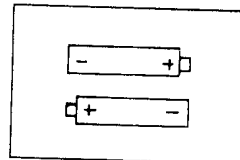

---

## CLEAR RANDOM ACCESS MEMORY (RAM) AND INITIALIZE CASH REGISTER

1. Place mode switch in **P** position.

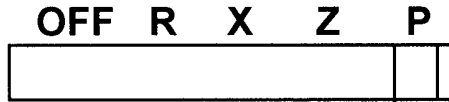

2. Connect the AC plug into a power outlet **while pressing the "C" and "00" keys.**
3. Then, RAM is cleared and cash register prints the symbol ".....".

NOTE : This is a one time only procedure to be performed after the battery is installed.  
DO NOT CLEAR RAM ONCE THE CASH REGISTER IS PROGRAMMED. TO DO SO WOULD CAUSE ALL PROGRAMS AND TOTALS TO BE LOST.

---

## LOAD PAPER

1. Cut or tear the end of a single paper tape evenly for proper feeding through the print head.
2. Place paper roll in the paper holder and insert the paper end straight into the paper inlet of the printer.
3. Depress the "**FEED**" key until the paper catches and advances through the printer.

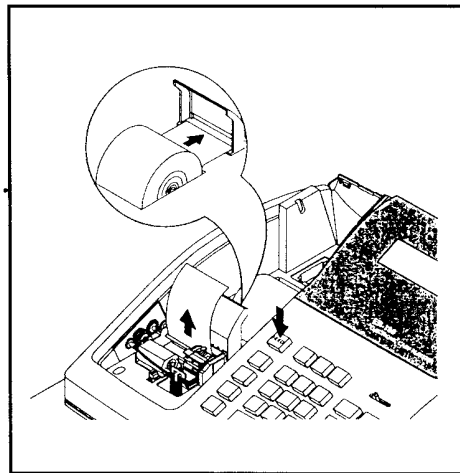

4. If the paper does not feed through the printer, make sure the paper was entered properly, insert end of paper tape.

FOR RECEIPT ONLY...

5. Pass the paper through the receipt window of the printer cover. Replace over printer compartment.

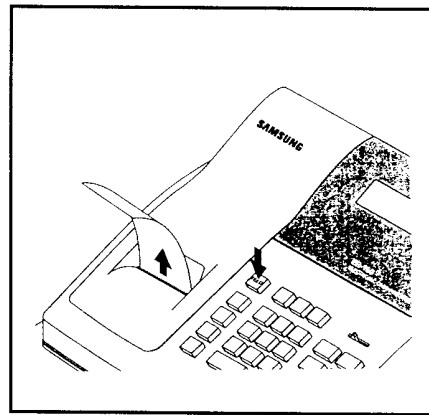

FOR JOURNAL ONLY...

6. Route paper over top of paper guide insert in the slot of the take-up spool.
7. Press "FEED" key to wind paper securely onto spindle.
8. Replace printer cover.

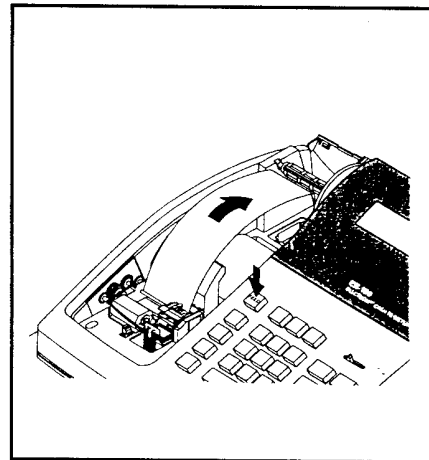

---

## HOW TO REPLACE THE INK ROLLER

The ink roller is a one-time article. Re-inking roller can cause damage to the printer and void warranty. Do not re-ink. When the print becomes faint, replace the ink roller as follows.

1. Remove the old roller by lifting of it.
2. Fit the new ink roller completely.

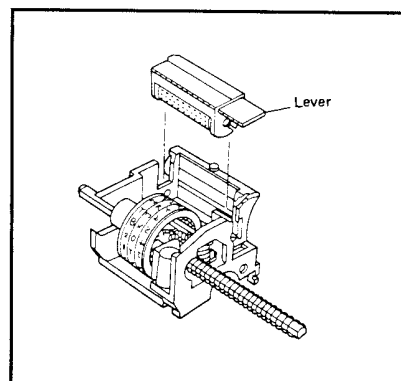



# FEATURES

---

## MODE SWITCH

- OFF** - Turns the cash register off. Any key can not be accessed.
- R** - To enter transaction.
- X** - To read financial report and C-I-D declaration.
- Z** - To read financial reports and reset totals to zero.
- P** - To program.

---

## DISPLAY

The display features fluorescent digits providing the customer with information about operation of the cash register. During operations, the display will show the following symbols. All these symbols appear in position 1 of the display.

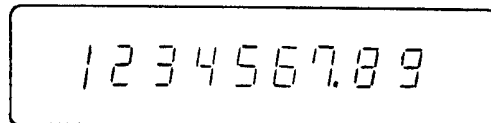

- C** : Indicates the amount displayed is due in change.
- =** : Indicates the amount displayed is the a total.
- : Indicates the amount displayed is a negative.
- E** : Indicates an error condition.  
Press the "C" key to clear error condition.
- S** : Indicates the amount displayed is a subtotal.

---

## KEYBOARD

FEED	RA	PO	X/RF	OFF R X Z P	
-	7	8	9	TAX	#/NS
%	4	5	6	DPT2	CH
VD	1	2	3	DPT1	SUB TOTAL
C	0	00			CASH TEND

---

## KEY FUNCTIONS

**FEED** Used to advance printer paper.

**0 - 9, 00** Used to enter the number.

**DPT1** These keys classify the items sold and  
**DPT2** memorize the quantities and amounts in their  
own memories.

**X/RF** Used for multiplication entry. (X)  
To allow for the return of merchandise by  
department. (RF)

**PO** To register any money paid out.

**RA** To register any money received on account.

<b>-</b>	To register an amount minus or coupon.
<b>%</b>	To register a percent discount (-%) or surcharge (+%) on an item or on a sale.
<b>VD</b>	To correct entries before a sale is finalized.
<b>C</b>	To clear incorrect entries made on the numeric keys. Also to clear error conditions and silence the error tone.
<b>TAX</b>	To program the tax rate in P mode. Also to enter the rate of tax in external straight tax method in R mode.
<b>#/NS</b>	To print the reference number or to open the cash drawer outside of a sale.
<b>CH</b>	To finalize the transaction in charge sales.
<b>SUB TOTAL</b>	To obtain the subtotal of a sale.
<b>CASH TEND</b>	To finalize cash sale and change calculation.

# PROGRAMMING

Read this entire section carefully to program the machine to the most preferable set-up according to your store system.

\* MODE SWITCH POSITION : P \*

---

## TAX, DECIMAL POINT INFORMATION

N1	N2	X/RF
----	----	------

	VALUE
N1	0 = 2 decimal 1 = non decimal 2 = 1 decimal 3 = 3 decimal
N2	0 = VAT 1 = add-on tax 2 = external straight tax

---

## DEPARTMENT STATUS

N1	DPT1	or	DPT2
----	------	----	------

N1	In case VAT, add-on tax	In case external straight tax
0	Non single, non tax	Non single
1	Non single, tax1	Single
2	Non single, tax2	
3	Single, non tax	
4	Single, tax1	
5	Single, tax2	

---

## TAX RATE

N1	N2	N3	N4	N5	N6	TAX
----	----	----	----	----	----	-----

	VALUE	COMMENTS
N1-N5	0.000 - 99.999	Tax rate
N6	0	External straight tax
	1	Tax1 (VAT or add-on)
	2	Tax2 (VAT or add-on)

---

## SETTING THE PERCENT(%) KEY

N1	N2	N3	N4	N5	N6	%
----	----	----	----	----	----	---

	VALUE	COMMENTS
N1-N5	0.000 - 99.999	Percent rate
N6	0	-%
	1	+%

---

## SETTING THE MACHINE NUMBER

N1	N2	#/NS
----	----	------

2 DIGITS

---

## RECEIPT PRINT / JOURNAL PRINT

N1	N2	<b>SUB TOTAL</b>
----	----	----------------------

	VALUE	COMMENTS
N1	0	Taxable, tax amount print
	1	Taxable, tax amount not print
N2	0	Receipt on
	1	Receipt off

---

## ROUNDING OPTION

N1	-
----	---

N1	COMMENTS
0	Not European, round up / down
1	Not European, round up
2	Not European, round down
3	European, round up / down
4	European, round up
5	European, round down

---

## SYSTEM OPTIONS

### OPTION 1

N1	N2	N3	N4	N5	RA
----	----	----	----	----	----

NO	OPTION	VALUE = 0	VALUE = 1
N1	CASH DECLARATION	NOT COMPULSORY	COMPULSORY
N2	ZERO SKIP IN REPORT	NOT SKIP	SKIP
N3	Z REPORT REPEAT	NOT REPEAT	REPEAT
N4	RF / VD / GROSS TOTAL PRINT IN REPORT	PRINT	NOT PRINT
N5	SUBTOTAL PRINT	PRINT	NOT PRINT

### OPTION 2

N1	N2	N3	N4	N5	PO
----	----	----	----	----	----

NO	OPTION	VALUE = 0	VALUE = 1
N1	GRAND TOTAL TO PRINT	PRINT	NOT PRINT
N2	GRAND TOTAL RESET AFTER Z REPORT	NOT RESET	RESET
N3	Z COUNTER RESET AFTER Z REPORT	NOT RESET	RESET
N4	CONSECUTIVE NUMBER AFTER Z REPORT	NOT RESET	RESET
N5	DATE PRINT	PRINT	NOT PRINT

---

## SETTING THE DATE

- SET MODE SWITCH TO THE "X" POSITION.

The date must be programmed daily and will be printed on all transaction receipts and on the totalizer printouts. To program the date, press the appropriate number keys, then press the "CH" key. Any single digit must be preceded by a zero.

M	M	D	D	Y	Y	CH
---	---	---	---	---	---	----

Ex) TO DATE TO BE PROGRAMMED IS OCTOBER 9, 1997

1	0	0	9	9	7	CH	10-09-97
	9	1	0	9	7	CH	09-10-97
9	7	1	0	0	9	CH	97-10-09

---

## REGISTER MODE OPERATION EXAMPLES

- MODE SWITCH SET TO "R" POSITION

This section provides examples of practice in the register mode. When an error occurs, the symbol "E" will appear on the display accompanied by an error tone. Clear this error condition by pressing the "C" key. The Error prompt may indicate an incorrect key has been entered, or a compulsory function has been performed.



## SAMPLE RECEIPT

VAT version	Add - on tax version
<b>10-09-97</b>	<b>10-09-97</b>
<b>1.00TX1</b>	<b>1.00TX1</b>
<b>2.00NT2</b>	<b>2.00NT2</b>
<b>3.00CA</b>	<b>1.00TX</b>
<b>1.00TX</b>	<b>0.05TX</b>
<b>0.04TX</b>	<b>2.00NT</b>
<b>2.00NT</b>	<b>0.12NT</b>
<b>0.11NT</b>	<b>3.00CA</b>
<b>001-77</b>	<b>001-77</b>

- Following example are based on VAT version.

---

### NO SALE OPERATION

A no sales operation opens the cash drawer outside of a sale. The financial report records the no sale activity counter.

<b>#/NS</b>	<b>..... NS</b>
	<b>002-77</b>

---

### NON ADD NUMBER ENTRIES

The **"#/NS"** key can be used to enter up 7 digits. The entry can be made prior to any operation in the register mode. This numeric entry will not add to any activity counts or totals.

<b>1</b>	<b>2</b>	<b>3</b>	<b>4</b>	<b>5</b>	<b>6</b>	<b>7</b>	<b>#/NS</b>
<b>12345.67 #</b>							

---

## DEPARTMENT OPERATION

### MULTIPLE ITEM DEPARTMENT ENTRY

	1	5	X/RF	15 X 2.00 30.00TX1 30.00CA 30.00TX 1.42TX
2	0	0	DPT1	
			CASH TEND	

### SINGLE ITEM DEPARTMENT SALES

NOTE : Even if a department is programmed as single item, the department is not processed as a single sale in case of another department had entered already.

	1	0	X/RF	10 X 1.00 10.00NT2 10.00CA 10.00NT 0.56NT
1	0	0	DPT2	

---

## MINUS (-) KEY OPERATION

### MULTIPLE MINUS OPERATION

5	0	0	DPT1
---	---	---	------

1	5	X/RF
---	---	------

5	0	-
---	---	---

CASH TEND
--------------

5.00TX1
15 X
-0.50 -
-7.50 -
-2.50CA
5.00TX
0.23TX

### MINUS SINGLE OPERATION

2	0	0	-
---	---	---	---

CASH TEND
--------------

-2.00 -
-2.00CA

---

**PERCENT OPERATION (%)**

**PERCENT DISCOUNT ON ITEM**

5	0	0	DPT1	5.00TX1 3.000 %- -0.15 4.85CA 5.00TX 0.23TX
			%	
			CASH TEND	

**PERCENT DISCOUNT ON ENTIRE SALE**

1	0	0	DPT1	1.00TX1 2.00NT2 3.00ST 3.000 %- -0.09 2.91CA 1.00TX 0.04TX 2.00NT 0.11NT
2	0	0	DPT2	
			SUB TOTAL	
			%	
			CASH TEND	

## MERCHANDISE RETURN OPERATION

2	0	0	DPT1
---	---	---	------

X/RF
------

2	0	0	DPT1
---	---	---	------

3	0	0	DPT2
---	---	---	------

CASH TEND
--------------

2.00TX1
.....RF
-2.00TX1
3.00NT2
3.00CA
3.00NT
0.16NT

## VOIDING ENTRIES (VD)

### LAST ITEM VOID / ERROR CORRECT

1	0	0	DPT1
---	---	---	------

2	0	0	DPT2
---	---	---	------

VD
----

CASH TEND
--------------

1.00TX1
2.00NT2
.....VD
-2.00NT2
1.00CA
1.00TX
0.04TX

**PREVIOUS ITEM VOID**

1	0	0	DPT1
2	0	0	DPT2
1	0	0	VD
			DPT2
			CASH TEND

1.00TX1  
 2.00NT2  
 .....VD  
 -1.00TX1  
 2.00CA  
 2.00NT  
 0.11NT

**TENDERING OPERATION**

**CASH TENDER**

1	0	0	DPT1
			CASH TEND

1.00TX1  
 1.00CA  
 1.00TX  
 0.04TX

**AMOUNT TENDERED ON CASH**

2	0	0	DPT1
3	0	0	CASH TEND

2.00TX1  
 2.00 TA  
 3.00AT  
 1.00CG  
 2.00TX  
 0.09TX

### CHARGE TENDER

- Amount tender operation is impossible on the charge tender.

3	0	0	DPT1	3.00TX1 3.00CH 3.00TX 0.14TX
			CH	

### SPLIT TENDER

The cash drawer should not open during split tender.

4	0	0	DPT1	4.00TX1 4.00 TA 2.00AT 2.00 TA 2.00CH 4.00TX 0.19TX
2	0	0	CASH TEND	
			CH	

---

### RECEIVED ON ACCOUNT (RA) OPERATION

7	0	0	RA	7.00RA
---	---	---	----	--------

---

### PAID OUT (PO) OPERATION

5	0	0	PO	5.00PO
---	---	---	----	--------

## MANAGEMENT REPORTS AND BALANCING

MODE	REPORT	KEY	COMMENTS
X	CASH IN DRAWER DECLARATION	AMOUNT - SUBTOTAL	AMOUNT = NUMERIC
X	FINANCIAL DAILY REPORT	CASH TEND	READ
Z			READ & RESET
X	P-T-D GRAND	CH	READ
Z	TOTAL		READ & RESET

---

### CASH IN DRAWER DECLARATION

In the system option 1 programming, cash-in-drawer declaration can be programmed compulsory. Cash-in-drawer declaration is performed by adding the total of each type of media in the drawer, and pressing the "SUBTOTAL" key. Depression of the "SUBTOTAL" key with numeric will enter the information that the cash-in-drawer declaration performed, and reports in X position and Z position will be allowed.

In this case, the difference of input amount and cash in drawer is displayed.

After this declaration, you can not take any registering operation, if not reporting in X mode or Z mode.

<b>10-09-97</b>	
<b>70.00CA</b>	TOTAL ENTERED BY KEY-INPUT
<b>70.26AT</b>	TOTAL IN CASH DRAWER
<b>-0.26</b>	DIFFERENCE
<b>021-77</b>	



---

## FINANCIAL DAILY REPORT

10-09-97	DATE
001 Z	Z COUNTER, MODE SWITCH POSITION
024 @	DEPARTMENT1 COUNTER
53.00TX1	DEPARTMENT1 TOTAL
025 @	DEPARTMENT2 COUNTER
30.00 2	DEPARTMENT2 TOTAL
53.00TX	TAXABLE1 TOTAL
2.47TX	TAX1 TOTAL
30.00NT	TAXABLE2 TOTAL
1.66NT	TAX2 TOTAL
-0.24 %-	PERCENT TOTAL
-9.50 -	(-) TOTAL
73.26 * 1	NET SALES TOTAL
-2.00RF	RETURN MERCHANDISE TOTAL
-3.00VD	VOID TOTAL
85.00 * 2	GROSS SALES TOTAL
016 #	CUSTOMER COUNTER
68.26CA	CASH TOTAL
5.00CH	CHARGE TOTAL
7.00RA	RECEIVED ON ACCOUNT
5.00PO	PAID OUT
70.26AT	CASH IN DRAWER
001 NS	NO SALE COUNTER
.....	
85.00 * 3	GRAND TOTAL
064-01	RECEIPT NUMBER, MACHINE NUMBER

---

## P-T-D GRAND TOTAL REPORT

001 *Z	
85.00 *4	P-T-D GRAND TOTAL

---

## SYSTEM BALANCING

NET SALES TOTAL = DEPARTMENT TOTALS  
(add positive, subtract negative)  
+ TAX TOTAL (add-on,  
external straight tax version  
only)  
+ % TOTAL  
+ (-) TOTAL

GROSS SALES TOTAL = NET SALES TOTAL  
- MERCHANDISE RETURN  
- (-) TOTAL  
- % TOTAL

ENDING GRAND TOTAL = GROSS SALES TOTAL  
+ PREVIOUS GRAND  
TOTAL

## MAINTENANCE

1. Avoid excess dust and extreme temperatures.
2. Be certain that AC cord is inserted firmly in the outlet, and that cord poses no danger of accidental tripping.
3. Use no chemicals or abrasives while cleaning cabinet or keyboard.
4. Do not pull or hold paper while the register is printing.

# SPECIFICATION

---

## DIMENSIONS

REG. SIZE	325 mmW × 420 mmL × 225 mmH
NET WEIGHT	5.0 kg

---

## DRAWER

SIZE	325 mmW × 420 mmL × 95 mmH
WEIGHT	3.3 kg

---

## MODE KEY

LOCK SWITCH	SLIDE SWITCH
POSITIONS	5 (OFF, R, X, Z, P)
RECEIPT ON / OFF	NONE (BY PROGRAM)

---

## KEYBOARD

TYPE	RUBBER CONTACT TYPE
NUMBER OF KEYS	26
KEYSTROKE BUFFER	8

---

## PRINTER

MODEL #	M-42V
STATIONS	1
PAPER	SINGLE PLY(57.5 mm OR 40 mm)
COPY	NONE
PRINT SPEED	2.2 LINE / SECOND

---

## DISPLAY

CAPACITY	9 DIGITS
SYMBOLS	5 (E, C, -, =, S)

---

## POWER

INPUT	AC LOCAL VOLTAGE $\pm 10\%$ , 50 / 60 Hz
CONSUMPTION	STANDBY : 2W, MAX : 8W
MEMORY BACK-UP	1 YEAR
BATTERY	AAM 1.5 Volt × 2, EQUIVALENT