

EX50 EXCIMER LASER MANUAL



GAM LASER, INC
6901 TPC DRIVE, #300
ORLANDO, FL 32822

Copyright

This operations manual has been copyrighted and is property of GAM LASER, INC. (Orlando, Florida).

It is intended for the private use of GAM LASER, INC. customers and may be used only for installing, operating, maintaining or servicing the equipment describe herein.

Without the expressed written consent of GAM LASER, INC, no part of this publication is to be reproduced or transmitted in any form; nor should the publication be disclosed to third parties.

Warranty Liability

No operation, service or maintenance of the equipment described in this manual may be performed unless under the supervision of GAM LASER, INC. personnel or persons authorized by GAM LASER, INC. All warranties on the laser system are negated if the procedures delineated in this manual are performed by unauthorized persons.

It is required that all persons involved in the operation, maintenance and/or service of this laser system, read, understand and observe the information and instructions given in this manual.

GAM LASER, INC. assumes no liability for any damage and/or malfunctioning of the equipment caused directly or indirectly from using or maintaining the laser in a manner that is not conforming to the contents of this manual.

1 INTRODUCTION	5
1.1 Quick Do's and Dont's of Laser Operation	5
1.2 HELPFUL HINTS	6
2 LASER OPERATION	7
2.1 Laser Specifications	8
2.2 Water Cooled Lasers	8
2.1. Vacuum UV Adapter	9
2.3 External Detector	10
2.4 Internal Detector	10
2.5 Manual Valve	10
2.6 Pressure Sensor	10
2.7 Refilling the Laser	10
2.8 Line Input	11
2.9 Fuses	11
2.10 Key Switch	12
2.11 Circuit Breaker	12
2.12 Gas Mixtures	12
2.13 Gas Cylinders	13
2.14 Thyatron Warm Up	13
2.15 Thyatron Reservoir Adjust	14
2.16 Triggering	14
2.17 External Triggering	14
2.18 Sync Out	15
2.19 Optics	15
2.20 Optics Cleaning and Exchange	15
2.21 Optics Mounts	17
2.22 Cleaning and Replacing Optics	17
2.2. Mirror Alignment	19
2.23 Command Charge	19
2.24 Thyatron Adjust	21
2.3. Measuring Thyatron Switching Jitter	21
2.25 Duty Cycle	21
2.26 Over Temperature Cut Out	22
2.27 Water Cooled Units	22
2.28 Cover	22
2.29 Interlock	22
2.30 Emission Indicator	23
2.31 Power Supply Faults	23
2.32 Vacuum Pumps	23
2.33 Thermal Calibration	23
3 GAS HANDLING	25

3.1	External Vacuum Pump	25
3.2	Internal Vacuum Pump and Filter	25
3.3	Adding a Cylinder of Premix Gas.....	26
3.4	Adding a Cylinder of helium Gas	27
3.5	Gas Cylinder Replacement with Internal Vacuum Pump.....	27
3.6	Changing the Excimer Operating Gas type.....	28
3.7	Fluorine Injection.....	29
3.8	Over Pressure Valve	29
4	CHAMBER EXCHANGE	29
4.1	Laser Operation From Software.....	29
5	LASER ELECTRONICS	31
5.1	Brief Description of Control Lines	32
5.2	Electronics.....	34
5.3	Command/Trigger Card.....	35
5.4	Pressure/Optical Card	35
5.5	Interface Card	36
6	TROUBLESHOOTING.....	37
6.1	Low Energy.....	37
6.2	Laser will not Laser and there is no Discharge	38
6.3	If there is a blue emission light and the laser still does not fire	38
6.4	There is noise when the blower motor starts	38

EX50 EXCIMER LASER MANUAL

JUNE 2006 EDITION

FOR MODELS EX50/250, EX50/500, EX50/750, EX50/1000

1 Introduction

The EX50 is a state of the art, high reliability, long life excimer laser utilizing total ceramic/metal construction. The laser is packaged in a compact single tabletop unit including a vacuum pump and halogen filter. The laser gas is supplied from a single premix gas cylinder.

1.1 *Quick Do's and Dont's of Laser Operation*

1. Do not operate the laser above the recommended fill pressure; this may result in permanent damage to the laser and thyatron or solid state switch.
2. Do not use gas mixture containing all Helium buffer gas, the laser is designed to operate with an Argon Fluoride gas fill which uses Neon as the majority buffer gas. Helium concentration in the buffer gas should be kept below 5%.
3. Do not under any circumstances allow the laser to "go to atmosphere", or partially go to atmosphere. This will cause permanent damage and the laser will require to be rebuilt.
4. Do not exceed a duty cycle of approximately 80% in laser operation over the long term for air cooled units, (1 hour) at the maximum repetition rate of 500Hz. For shorter periods of time the laser should be operated for no greater than 20 minutes at maximum repetition rate. Water cooled units can be operated at maximum duty cycle.
5. Do not exceed a maximum high voltage input of 16 kV. Note that the high voltage is controllable up to 20 kV by placing 5V on pin 25 of the main 25 pin connector, however hardware protection will prevent the high voltage exceeding 16.6kV. In constant energy mode the laser must be refilled once the high voltage reaches 16 kV. A hardware limit on the interface card limits the maximum high voltage, which can be applied to the laser head to 16.6kV. No matter what the voltage applied to pin 25.
6. Do always pump out the gas line and the laser manifold after a new tank of gas is added or any of the gas or vacuum lines are exposed to air. This can be done automatically from EXLASER software. The main valve on the gas cylinder must be closed during this procedure. **During this operation the main solenoid valve to the laser MUST remain closed.**
7. A halogen filter is connected to the gas vent inside the laser. The Halogen filter is rated for more than 500 complete laser refills. This number should exceed the cumulative shot lifetime of the laser. The halogen filter may be replaced during factory rebuild.
8. Whenever possible use the PARTIAL GAS REFILL method of refilling the laser. Four partial gas refills is equal to one total refill. The partial gas refill method

- prevents any air leaking into the laser from possible leaks in the premix tubing lines and regulator. Air leaks will particularly effect Argon Fluoride 193nm operation.
9. Do insure that there are no air leaks in the premix or Helium gas lines. Small quantities of air entering the laser will reduce energy output. Larger amounts of air will damage the laser to the point that a complete refurbishing is required.
 10. Do provide sufficient ventilation to allow the air from the laser air cooling fan exhausts to freely escape. The room temperature should be no greater than 21C (70F) for high duty cycle operation.
 11. Do clean the optics after the recommended 100 million pulses with ArF to obtain the best energy performance. The output coupler may require replacement at this interval, tests have shown that the Max. R will last longer.
 12. Do use only research grade gases to obtain the best gas lifetime, lower grade gases will result in reduced gas lifetime.
 13. The laser is fitted with a manual shut off valve. This valve is used when the laser vessel is exchanged or when it is necessary to isolate the laser vessel from the valve system. The valve may also be used to isolate the laser vessel during shipment. Inexperienced users experimenting with the solenoid valve system are advised to place the shut off valve in the closed position. The valve must be open for normal laser operation.
 14. If the laser is in regular operation, service should be scheduled after every 6 months of operation. At scheduled service the following should be carried out:-
 - a) Optics should be cleaned or replaced
 - b) The internal optical elements associated with the energy detector should be cleaned.
 - c) The thyatron filament voltage tested and reset if required.
 15. Do not block the cooling vent inlets or outlets; this will cause the laser to overheat.

1.2 HELPFUL HINTS

1. The laser should be filled with Neon or Helium or active premix gas to approximately 10PSI, (1200 torr) for shipment.
2. A cover interlock is located on the left hand side of the laser, looking from the front. The interlock must be engaged for the laser to operate. If the interlock is not engaged no high voltage will appear on the laser head. Remote interlock is located on the rear panel of the laser; this interlock must also be engaged in order to run the laser.
3. A cooling fan connection is located on the left hand side of the laser, looking from the front. The fans must be disconnected to remove the cover. The fans must be reconnected when the cover is replaced.
4. During optics cleaning or replacement the laser requires flowing inert gas, typically Helium, Neon or Dry Nitrogen. After exchange of optics or optics cleaning the laser shelf life may be reduced. The shelf life should return to specified levels after 1-2 gas fills.
5. Make certain that the laser setup in software matches the laser model number. To setup the software, go to the SETUP screen from the menu bar on the main screen.

2 Laser Operation



Before operating the system, Make sure the emergency offswitch is pulled out to allow AC power to be applied.

The laser can be switched on by bringing the circuit breaker located on the rear panel of the laser to the ON position after the unit is plugged into the line. This will cause the yellow indicator lamp on the rear panel to illuminate and a sonalert to sound for approximately 5 seconds. The yellow indicator light means that the 12V electronic power supply is operating correctly.

Lasers with thyatron should be allowed 5-8 minutes to warm up the thyatron. The HY10 thyatron requires a 5 min warm up, the F-130 requires an 8 minute warm up.

2.1 Laser Specifications

PARAMETER	F2	ARF	KRF	XECL	XEF
Wavelength nm	157	193	248	308	351
Energy Max. mJ	2.5	35	50	22	20
Average Power @ 250Hz	0.5	5	10	5	5
Average Power @ 500 Hz	1	10	20	10	9
Average Power @ 1K Hz	2	17	35	17	16
Average Power @ 2K Hz ^a	3	32	60	32	30
Dynamic gas lifetime Pulses to 50% energy	15E6	25E6	35E6	30E6	30E6
Industrial Version	40E6	100E6	500E6	100E6	400E6
Shelf life approx. to 50% energy	15 days	90 days	120 days	> 1 year	120 days
Window Service	300E6				
Repetition Rate	250/ 500/ 750/ 1000/ 2000 Hz				
Pulse Length	17-20 nS ^b				
Beam Size	9 X 4 mm ^c				
Stability	< 2% Standard Deviation ^d				
Divergence	0.8 X 1.6 mRad ^e				
Cooling	Air 250,500 Hz/ Water 1000Hz				
Tube Service	> 3 Billion Pulses				

2KHz Version sold only for scientific purposes - Industrial Version not available

b At Max. Voltage

c FW at 20cm from the laser.

d typical

e Full Width Half Max.

2.2 Water Cooled Lasers

The EX50/750 and the EX50/1000 are water cooled units. To insure proper operation water flow at approximately 25°C temperature or lower is required at a flow rate greater than 3 liters/minute. Water quick connections are located on the right hand side of the laser.

2.1. Vacuum UV Adapter

Optimized 157nm F2 lasers are supplied with a vacuum UV adapter. The adapter screws into the output coupler mirror mount and is terminated at the other end with a 3/4" Kwik Fit vacuum connection for mating the laser system to a purge or vacuum system.

NOTE: Care should be taken when unscrewing the VUV adapter that the mirror mount retaining ring does not move. Loosening the mirror mount retaining ring will result in laser gas leaking into the air.

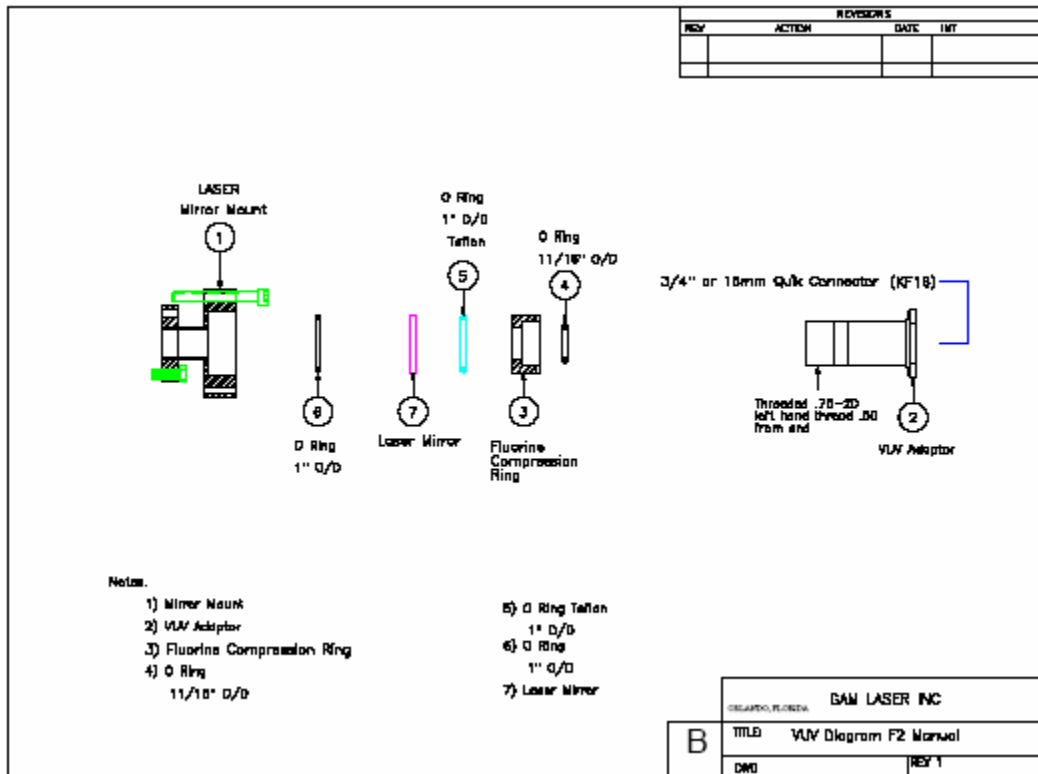

For 157nm operation, the region between the output coupler and the user system must be flushed with inert gas or nitrogen.

Note: VUV Adapter has a left hand thread



Parts List

Installation

VUV in Place

2.3 External Detector

An External detector should be used to calibrate the internal energy sensor using software factors. Or by adjusting the internal detector gain potentiometer on the optical card located in the electronics compartment of the laser. An optional external detector is available from Gam Laser, which interfaces with the laser and software package.

2.4 Internal Detector

The internal energy detector is a Silicon photodiode. The diode provides an uncalibrated output and calibration should be carried out with an external traceable energy detector. The calibration may be set in hardware by adjusting the potentiometer located on the optical card in the electronics compartment. An ultraviolet optical element is mounted at the input to the photodetector, this element and the 45 degree turning mirror should be carefully cleaned during service. Contamination on the optical surfaces will result in an apparent decrease in laser output energy. The internal detector does not function with the broadband maximum reflector option since the Aluminized coating does not transmit any laser energy

2.5 Manual Valve

The laser head is fitted with a manual shut off valve. The valve is located at the rear of the laser head inside the system, the laser system access cover must be removed to access the manual shut off valve. This valve is used when the laser vessel is exchanged or when it is necessary to isolate the laser vessel from the valve system. The valve should be turned fully clockwise to seal and counterclockwise to open for normal operation. This valve must be open to use refill the laser.

2.6 Pressure Sensor

The pressure sensor is designed to determine the fill pressure of the laser and is not accurate at the low pressure end of its range. The pressure sensor may be adjusted using the potentiometer on the pressure card located in the electronics compartment. The thermocouple gauge located at the top of the halogen filter should be used to measure low pressure and to obtain leak tight operation of the pump, fill and buffer/purge lines. The pressure sensor should be calibrated using the pressure gauge on the premix or Helium tank regulator if the reading is in doubt.

2.7 Refilling the Laser

The laser is designed for completely automatic gas refill, using the EXLASER control software. For this purpose 2 gas connections and 4 solenoid valves which can be controlled from the 25 pin connector are provided. An over pressure relief is also fitted to the laser. The laser vessel may also be sealed off with the internal manual valve. This valve is normally in the open position and is only closed for laser head replacement.

The 3 gas connections are, Gas vent, Premix and Buffer. The Premix connection is the lowest 1/4" swagelock connection, followed by the Buffer 1/4" swagelock connection and the gas vent 1/8" swagelock connection. A cylinder of premix laser gas should be connected to the premix connection to fill the laser. The buffer line should be attached to a tank of buffer gas, or to a tank of purge gas. The buffer gas and the purge gas may be used for window cleaning and replacement. Additionally the buffer gas may be used to adjust the gas mix.

2.8 Line Input

The standard EX50/250 and EX50/500 models are universal input devices designed to operate in the line input range of 100--132Vac 47/63 Hz and 180-240Vac 47/63Hz. The EX50/250 and the EX50/500 lasers are shipped for operation at the lower voltage range. For operation at the higher range with these units the input lines to the high voltage power supply must be switched. Consult GAM for the details of this change. The EX50/750 and the EX50/1000 operate at the 180-240Vac range only.

2.9 Fuses

The main fuse is located on the rear panel of the laser, the value of the fusing is shown in the table below. Fuses F2 through F6 are located inside the laser on a bracket located underneath the electronics box. The fuses are accessible from the side access panel on the laser cover. **MAKE CERTAIN TO UNPLUG THE UNIT FROM THE LINE BEFORE ACCESSING FUSES**

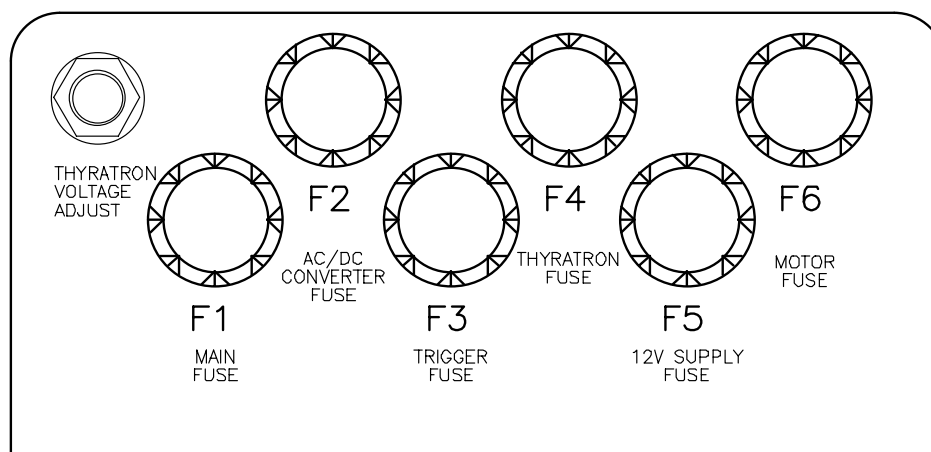

Fusing

		EX50/250	EX50/500	EX50/750	EX50/1000
AC Input		110/220	110/220	185-240	185-240
Main Fuse	F1	10A/5A	15A/8A	12A	15A
ARM	F2	5A	5A	5A	5A
Trigger Fuse	F3	1/4A	1/4A	1/4A	1/4A
6.5V Module	F4	.75A	.75A	.75A	.75A
12V Module	F5	.5A	.5A	.5A	.5A
24V Module	F6	.75A	1A	1.7A	1.5A

Make certain to change the fusing when moving from 110V to 220V operation.

2.10 Key Switch

The key switch must be in the ON position for laser operation. The laser can not be operated with the key removed. Do not lose the key, each key is unique to each laser system. The replacement of the key requires complete key switch replacement.

2.11 Circuit Breaker

The circuit breaker is a 10-20A circuit breaker depending upon the particular laser unit. The breaker is required to be in the ON position for laser operation.

2.12 Gas Mixtures**ArF**

0.17% F₂
 6.0% Argon
 1% Helium
 Add 10ppm Xe and 15ppm O₂
 Balance Neon to 2375 torr.
 Spectra Gases part # EXOGAMFAHN-3; 2000 liter size

KrF

0.18% F₂
 3.75% Kr
 1% Helium
 15 ppm Xe
 Balance Neon to 2375 torr.
 Spectra Gases Part # EXOGAMKFHXN-3; 2000 liter size

XeCl

0.85% Xenon

0.02% Hydrogen

0.1% HCl

Balance Neon

Spectra Gases Part #EXOGAMXECL-4; 1000 liter size

XeF0.25% F₂

0.78% Xenon

1.0% He

Balance Neon

Spectra Gas Part # EXOGAMXEFL-4; 1000 liter size

F2 157nm0.09% F₂

Balance Helium to 2800 torr.

NO OTHER ADDITIVES

Spectra Gases Part #EXOGAMF2HE-3; 2000 liter size

2.13 Gas Cylinders

For long term ArF operation the laser requires to be attached to two gas cylinders. One cylinder of premix laser gas and a purge/buffer gas cylinder, typically the purge/buffer cylinder is Helium. The regulator on the premix cylinder should be set to between 40 and 50 PSI gauge. The regulator **must not be set above 50 PSI gauge**. The purge/buffer regulator should be set to approximately 5 PSI gauge and must not be set above 10 PSI gauge. For shipment it is best to fill the laser with buffer gas to approximately 1000 torr. The gas cylinders must be connected to the gas ports on the EX50 laser with 1/4" stainless steel or Copper tubing, plastic or Teflon tubing is not suitable and can not be used.

2.14 Thyatron Warm Up

For lasers switched by thyratrons, the thyatron is a heated electron tube and requires at least an 8 minute warm up. The EX50 uses a 3" diameter thyatron, which requires a longer warm up time than the 2" thyratrons used on the EX10. Do not attempt to operate the laser before the 8 minute warm up time, damage to the thyatron will occur. Lasers with ASSE's require no warm up time.

2.15 Thyatron Reservoir Adjust

During the lifetime of the thyatron which is approximately 10,000 hours or 5 billion pulses, whichever comes first, the reservoir voltage may have to be increased. Poor pulse to pulse stability from the laser output may be due to a low reservoir voltage. The heater and reservoir voltages on the thyatron can be adjusted using the potentiometer located inside the laser on the left hand side, near the left had access panel. The thyatron filament voltages must not exceed 6.9V. The software THYRATRON FILEMENT VOLTAGE indicator will turn red if the voltage goes above this value. The filament voltage must be adjusted to be in the range 6.3-6.75V

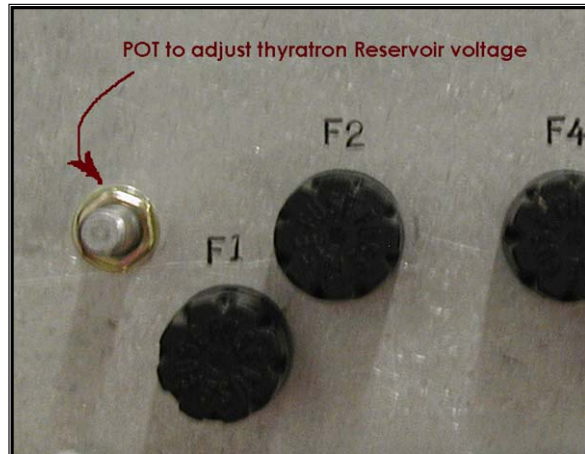

2.16 Triggering

The laser requires a 5V trigger pulse on pin 1 to fire the laser. In command charge mode the rising edge of the pulse causes command charge to begin and the laser will fire 2mS later. In DC charging mode the laser will fire immediately upon application of the trigger pulse rising edge. A 5V signal on pin 1 pulsed or DC causes the blue emission indicator LED on the laser front panel to illuminate.

2.17 External Triggering

External triggering can be accomplished by attaching a **5V** trigger source to the BNC connector located on the **right hand side** of the electronics panel, looking at the panel. The external trigger can operate in command charge mode or DC charging mode. Note: Units with the standard control package have no limitation on applied external triggering rate. Therefore care must be taken not to exceed the maximum repetition rate specified for the particular laser model. Systems with the enhanced control package automatically limit the maximum repetition rate. The trigger source pulse must be at least 2 microseconds long. External triggering for low jitter using the DC charge mode requires a fast rise time external trigger pulse <50nS. Note the external trigger BNC input should be terminated with a 50 ohm BNC impedance on a BNC tee at the rear panel of the laser.

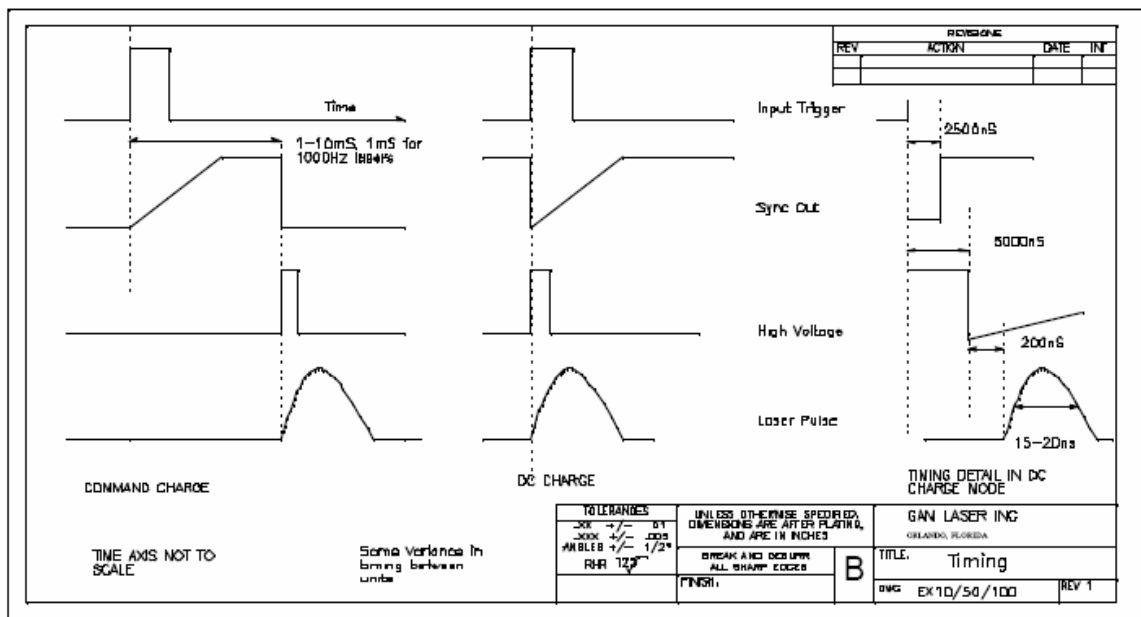

2.18 Sync Out

The BNC on the **left hand side** provides a sync out signal simultaneous with thyatron firing. The sync out signal is a positive going 5V pulse 140 microsecond long. Any positive going signal on the external trigger BNC causes the blue LED located on the front laser panel to illuminate.

2.19 Optics

The laser mirrors are made from the highest quality ultraviolet grade materials, however damage to the mirror coatings may be observed over time, particularly with ArF. The mirrors may need replacement with ArF after approximately 200 million pulses of operation, to restore the laser output energy to original values. After 200 million pulses a 50% reduction in laser output energy can be expected. Failure to replace the optics will result in low laser output energy. Cleaning the optics may increase the output energy without requiring replacement of the optics.

The laser is typically equipped with optimized dielectric coated optics for the chosen laser gas. However a broadband maximum reflector is available for operation on all excimer laser wavelengths without exchanging the laser optics. When the broadband maximum reflector is used the output energy of the laser is reduced by approximately 5% and internal energy monitoring is not available.

2.20 Optics Cleaning and Exchange

The recommended optics cleaning solvent is dichloromethane, this material can be obtained from Aesar chemicals in Massachusetts. All procedures involving the cleaning or replacement of optics must be carried out with **clean gloves** or finger cots. Optical polish such as fine grade Alumina Oxide, Cerium Oxide or optical Rouge is required to

polish the internal surfaces of the optics if the optics are to be reused. A new set of optics to replace the old optics can be purchased from GAM Laser, Inc.

The laser requires a cylinder of Helium or buffer gas such as Argon or Neon to be attached to the buffer gas port of the laser. The Helium/buffer port is the second gas port from the bottom. The Helium/buffer gas line must be pumped out for 10 minutes before opening the Helium/buffer gas tank in order to remove air from the Helium/buffer gas line and the line should be flushed a few times with buffer gas. The regulator on the tank of Helium/buffer gas should be set to approximately 3 PSI and all tank valves placed in the open position.

Once the Helium/buffer gas cylinder is attached and the gas line pumped out and pressurized the optics cleaning/exchange can begin.

- a) Pump out the active laser gas from the laser chamber. To do this manually, use the PUMP OUT control located on the ADVANCED screen of the software. Pump the laser out for at least 5 minutes.
- b) Shut down the pump using the CLOSE ALL VALVES control in the ADVANCED screen.
- c) Fill the laser with Helium/buffer gas using the HOLD HELIUM OPEN control. The laser pressure should rise to approximately 1200 torr.
- d) Close the Helium/Buffer line using the CLOSE ALL VALVE command.
- e) Pump out the laser again using the PUMP OUT command for at least 5 minutes.
- f) Shut the pump down using the CLOSE ANY VALVE command.
- g) Fill the laser with Helium/buffer again using the HOLD HELIUM OPEN command and leave the command active so that the Helium/buffer line remains open.

The laser optics can now be removed one at a time and cleaned or exchanged. During the cleaning process Helium/buffer gas will flow from the laser chamber when the optics are removed. This flow prevents air entering the laser.

The optics may be removed by unscrewing the optics retaining ring. If the optics is to be removed from the laser optics mounts for more than approximately one minute, the supplied plug should be used in the optics mount. This Aluminum plug seals the optics mount for long periods of time so that the optics may be thoroughly cleaned or inspected.

Once both optics are cleaned or exchanged the laser can be refilled with premix gas.

- a) Use the PUMP OUT command to pump out the Helium/buffer gas for at least 5 minutes.

- b) CLOSE ALL VALVES
- c) Use the FILL LASER command to fill the laser to approximately 2000 torr with PREMIX gas.
- d) CLOSE ALL VALVES
- e) PUMP OUT the laser again for at least 5 minutes.
- f) CLOSE ALL VALVES
- g) Use the FILL LASER command to fill the laser to 2000 torr
- h) CLOSE ALL VALVES.

The laser is now filled to 2000 torr with PREMIX gas. Go to the MAIN screen and then the REFILL Screen. Unlock the gas fill controls and use the PARTIAL GAS REPLACEMENT command to bring the laser up to operating pressure. The laser is now ready to run. The laser mirrors may require realignment. Consult the bench alignment section.

2.21 Optics Mounts

The laser mirror optics can be adjusted by tightening or loosening the four socket head screws located 90 degrees apart around each mirror mount. The optics are sealed in with Viton 'O' rings, make certain the 'O' ring is installed correctly when the optic is changes or cleaned. A fiber washer is located on the outside of the optic between the optic and the sealing ring, the fiber washer must be correctly inserted otherwise the optic may be damaged or cracked. A special tool provided with the laser is used to tighten and loosen the optics seal ring. Do not over tighten the seal ring, tighten till finger tight.

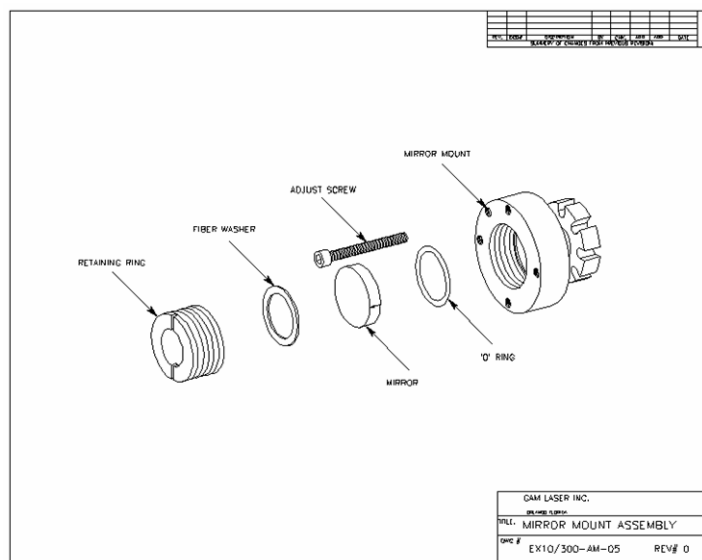

2.22 Cleaning and Replacing Optics

The mirrors terminating the laser cavity may require cleaning or replacement from time to time. To change or clean the optics a cylinder of Helium must be attached to the Helium gas port of the laser. The Helium gas port is the 1/4" swagelock port located

above the premix port. Neon gas or argon may also be used to purge the laser when cleaning or replacing optics. Make certain the optics 'O' ring and the fiber washer are reinserted after optics service.

BENCH ALIGNMENT OF THE LASER

The laser mirrors can be aligned using a Helium Neon (HeNe) laser or low divergence diode laser using the arrangement shown in Figure 1.

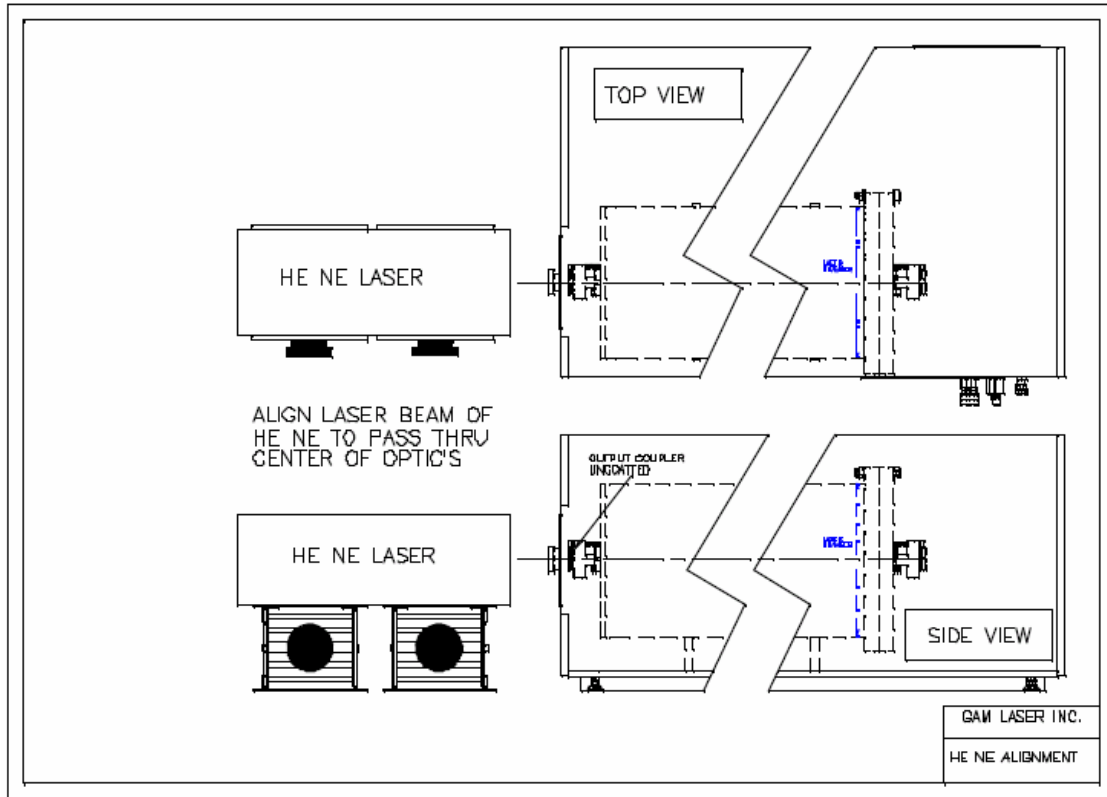

The excimer laser should be switched off for this procedure. The front and rear mirror panels must be removed for this procedure. A white card should be attached to the front of the HeNe laser. The card must have a central hole, which allows the exit of the HeNe beam. The HeNe laser should be mounted on laboratory jacks approximately 25 cm in front of the excimer laser. The HeNe laser is passed through the center of the output coupler optic and the center of the maximum reflector optic and exits through the rear mirror panel on the laser. The HeNe laboratory jacks should be adjusted until the beam passes through the center of both the optics. This can be achieved quickly with a little practice.

When the HeNe beam is set up to pass through the centers of both mirrors, two reflected beams should be observed on the white card, one from the front and one from the rear mirror. The rear reflected beam will have a larger diameter than the reflected beam from the front mirror. The beam positions can be adjusted using the mirror mount adjustment screws shown in figure 2. If the reflection from the rear mirror is not seen on

the white card some random adjustment of the rear mirror mount may be required to find the reflected beam, a darkened room makes the alignment procedure simpler.

When both the front and rear reflected beams are visible on the white card, the beams should be adjusted using the optics mount adjustment screws to be centered on the output of the HeNe laser. The beams are then reflecting back, upon the output of the HeNe and the two excimer laser optics are aligned roughly.

The excimer laser can now be switched on and allowed to warm up. After warm up run the laser and observe the laser output on a white card and an energy meter. The beam will likely not be perfectly aligned due to the wedges on the laser mirrors. To complete alignment adjust the front mirror to make the output beam a rectangle. This should also increase the output energy measured on the energy meter. Generally horizontal adjustments will give the greatest energy increase. Be sure that the optics adjustment screws are relatively tight after the alignment to insure long term alignment is maintained.

The laser is now almost perfectly aligned and can be used with this alignment. However, slightly better energy and alignment can be obtained by walking the mirrors.

2.2. Mirror Alignment

The mirrors are best aligned using a HeNe laser. Correct alignment is critical in achieving maximum laser performance. A HeNe laser should be fired down the axis of the optics at each end of the laser when the laser is filled to operating pressure. Adjusting the 4 screws on each mirror mount aligns the laser. After alignment with the HeNe laser it will typically be necessary to optimize the laser output by adjusting the output coupler of the EX50 to achieve maximum laser energy in a symmetrical rectangular beam.

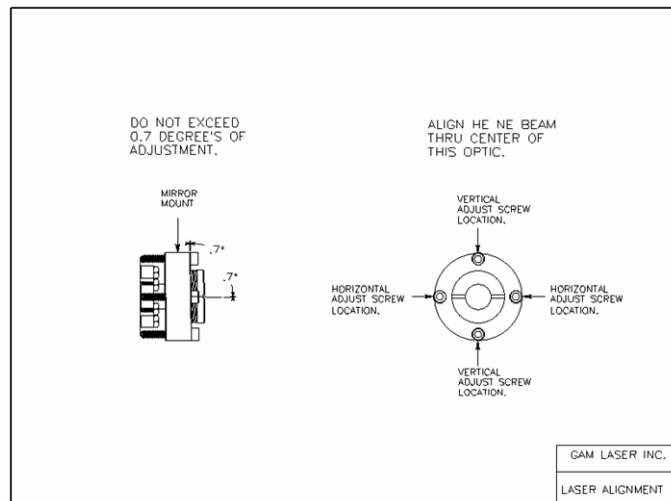

2.23 Command Charge

The laser operates in high voltage command charge mode. This means that high voltage is applied to the main capacitors a short time, typically 2mS for 500Hz operation, before the laser fires. The time between the trigger command being applied to pin number 1 on the external J25 connector and the time the laser fires will be approximately 2 mS. A sync out connection is provided on a BNC connector located on the rear electrical panel of the laser. The signal from the sync out is synchronous with the trigger signal applied to

the thyatron. The high voltage power supply is inhibited for a period of approximately 20 microseconds after the thyatron fires. This allows the thyatron or ASSE to return to a state of high voltage hold off before high voltage is again applied and avoids LATCH UP. The 20 microsecond inhibit results in a 2% decrease in power supply capacity when the unit is operated at 1000Hz.

2.24 Thyatron Adjust

For lasers using thyatron high voltage switches, the nominal operating conditions for the thyatron filament voltages are 6.4 V on the heater and the reservoir. Some thyatrons require a higher voltage than this for optimal laser performance.

The thyatron requires an occasional adjustment of the reservoir voltage. Generally as the thyatron accumulates pulses the voltage on the reservoir should be increased slightly. A condition where the thyatron fails to trigger occasionally may be caused by a low reservoir voltage and can be corrected by increasing the reservoir voltage. The reservoir adjust potentiometer is located inside the laser on the AC power box located at the back right hand side of the laser. The reservoir adjust potentiometer is sealed in position during final test, the seal must be broken to adjust the reservoir voltage. Using a DC voltmeter slightly increases the reservoir voltage if the thyatron is showing any preflaring. After adjustment the potentiometer should be resealed to prevent any change in the reservoir voltage due to vibration.

2.3. Measuring Thyatron Switching Jitter

Tools: Fast Photodiode detector, digital oscilloscope, 5V external trigger generator, BNC TEE connector and BNC cables.

1. Set the Photodiode detector to measure the optical pulse. Use a reflection off a card and make certain not to saturate the detector. Optical pulse length should be approximately 12ns at 12kV.
2. Use the laser in external trigger mode, provide an external trigger.
3. Very important: Set the laser to operate in DC charge mode.
4. Trigger the scope EXT TRIG and the laser EXT TRIG from the same pulse; use a BNC TEE connector.
5. Connect the photodiode output to a scope channel and use the scope with external trigger mode.
6. Observe the laser optical pulse on a 25ns/div scale.
7. Use the scopes ACQUIRE function to store 32 pulses and obtain the jitter over 32 pulses.
8. The jitter in EX50 laser which have not had special jitter testing will be in the 10-30nS range.
9. Laser set up for critical timing applications which have had special jitter testing will be in the 2nS range.

2.25 Duty Cycle

Air cooled models of the laser should be operated at a reduced duty cycle depending upon ambient temperature. In general a maximum long term duty cycle at maximum repetition rate of 80% is recommended. For example 10 minute on 2 minutes off, with the internal blower motor also switched off. The duty cycle is affected by room temperature and may be higher or lower than 80% at maximum repetition rate depending upon

ambient conditions. Typically 80% duty cycle can be achieved at below 21C-(70F) room temperature. The thermistor located on the laser head should be utilized to determine duty cycle in particular situations

2.26 Over Temperature Cut Out

A thermistor temperature sensor is attached to the laser vessel. It is recommended that the laser vessel not exceed a temperature of 50 degrees centigrade. In general the laser should not operate above 45 centigrade. 45 centigrade should be used as a software over temperature warning and 50 centigrade should be used as an over temperature shut down. A temperature sensor is also included inside the high voltage power supply. If the high voltage power supply exceeds it's operating temperature, a fault is shown at the summary fault line. If an air cooled laser model is placed within an enclosed box, the air flow through the enclosure must exceed 600 cfm to obtain sufficient air flow to cool the laser to obtain maximum duty cycle. Water cooled lasers can be set in software to cut out above some temperature, the default cut out temperature of water cooled lasers is 50C.

2.27 Water Cooled Units

The EX50/750 and the EX50/1000 are water cooled lasers. The EX50 may be used water cooled and air cooled. The cooling water connections are quick connect style located near the gas ports. There is no preferred cooling water flow direction, water flow of approximately 3 liters per minute is recommended. If GAM LASER with the laser system does not supply a water chiller a water cooler with a capacity of 1000W is required for the EX50/500, 1500W for the EX50/750 and 2000W for the EX50/1000. The water temperature should generally be set to 28C except when running ArF (193nm), in which case the water temperature should be set to approximately 38C.

2.28 Cover

The laser cover is an important component in the EMI shielding of the device. The cover should be secured with all screws during operation to minimize radiated electrical noise.

2.29 Interlock

The laser cover is interlocked to the high voltage, removing the cover or breaking the interlock will switch the laser off. Pin 22 of the 25 pin connector on the rear panel provides an output signal to monitor the interlock condition. Enable input is available on pin 5 of the J25 connector; this input may be used as remote interlock. The laser is enabled when pin 5 is raised to 5V. A 9 pin remote interlock is located on the laser rear panel. Pins 1 and 2 must be shorted to allow the laser to operate.

2.30 Emission Indicator

The emission indicator is a blue LED located on the front panel and comes on when the laser triggers and remains on continuously until the laser has stopped firing. Any trigger input on pin #1 of the J25 connector will cause the emission indicator to be on. A blue LED light on the front panel of the laser indicates that the trigger signal input, to pin 1 on the 25 pin connector is present. This is a useful indicator in troubleshooting. The emission indicator will illuminate when an external trigger source is connected to the right hand BNC on the rear panel of the laser.

2.31 Power Supply Faults

The 25 pin connector J25 pin 23 is the summary fault output. When this output goes low the power supply has a fault condition. The fault is either occurs when any of three conditions occurs, line voltage is low, that is below approximately 100V ac, over temperature, the power supply temperature is too high or the high voltage output is shorted to ground. Power supply faults are shown in software.

2.32 Vacuum Pumps

If an external vacuum pump is used, a pump with a capacity of at least 2 CFM is recommended. The pump should be connected to the "vacuum pump" connection on the rear laser panel through a halogen filter. The vacuum pump connection is only available on lasers with the external vacuum pump option.

2.33 Thermal Calibration

Tools required:

- a. Temperature measurement device
 - b. Styrofoam cup full of ice and water
 - c. Mini screw driver
1. Remove the rear panel of the electronics box on the laser.
 2. Remove the main cover from the laser.
 3. Make certain the laser is unplugged and switched off.
 4. Remove the thermistor from the rear right (looking from the rear of the laser) foot mount of the laser chamber.
 5. Switch on the laser and set the software to the ADVANCED screen to view the laser temperature.
 6. Immerse the thermistor in the ice water.
 7. Adjust the thermal OFFSET using the mini screwdriver, this is the central potentiometer mounted on the back of the interface card. Consult the manual photograph to see the position of the pot.
 8. The thermal OFFSET should be set to the minimum, normally the temperature will read 2-4C at the minimum value. Adjust only the thermal OFFSET.

9. Remove the thermistor from the ice water and dry it off. The temperature will increase, adjust the SLOPE to bring the temperature on the thermistor equal to the temperature on the independent temperature measurement device. The SLOPE potentiometer is located on the left side of the OFFSET. The SLOPE is nearest the 25 pin connector on the rear of the interface card.
10. Once the temperature reads the same as the standard redo steps 6-9. This is because the OFFSET changes slightly with slope, especially if the temperature is far out of calibration.
11. Reattach the thermistor and replace the cover and electronics panel.

3 GAS HANDLING

THIS SECTION IS VERY IMPORTANT AND SHOULD BE FOLLOWED TO INSURE CORRECT LASER INSTALLATION.

3.1 External Vacuum Pump

THIS SECTION IS APPLICABLE ONLY TO LASER SYSTEMS WHICH USE AN EXTERNAL VACUUM PUMP. FOR LASERS WITH INTERNAL VACUUM PUMPS GO TO SECTION 3.2.

3.2 Internal Vacuum Pump and Filter

THE FOLLOWING INSTRUCTIONS SHOULD BE READ FOR LASER SYSTEMS USING THE INTERNAL VACUUM PUMP AND HALOGEN FILTER

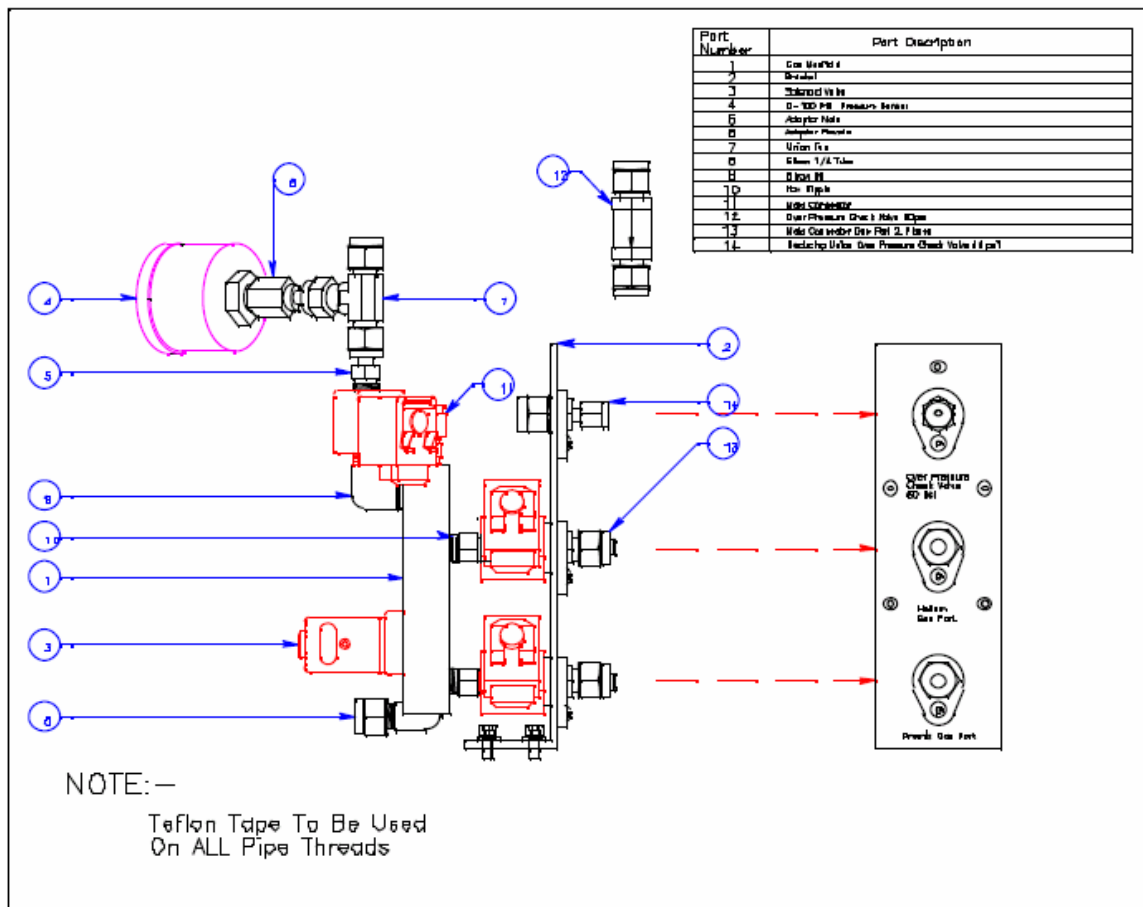

The vacuum pump and halogen filters are housed inside the laser package. An additional solenoid valve not included in systems, which use external vacuum pumps, is added to the gas handling system. The additional solenoid is located between the vacuum

pump and the halogen filter. The valve automatically opens each time the vacuum pump is switched on. Units with the internal vacuum pump and filter require no baking of the halogen filter unit.

Lasers that do not use the GAM software package will require to make changes adjustments to software control to operate the laser with the internal vacuum pump. This is because the internal vacuum pump has somewhat different properties than the external vacuum pump. **The internal vacuum pump can only start when the pressure within the pump is at atmospheric pressure**, if the pump is under vacuum it will not start. Therefore the pump should be raised to atmospheric pressure by opening the pump and main solenoid valves for approximately 1.5 to 2 seconds simultaneously while the pump is switched on, the pump and solenoid valves may then be shut. This action allows gas from the laser chamber to flow to the pump and insure that the pump is at atmospheric pressure when it starts. This is not an issue for pumping out the laser since the pump and main valves are opened in any case. However for pumping out the premix or Helium lines, the pump and main valves should be opened for 1.5-2 seconds to insure that the vacuum pump starts. The valves can then be closed and the appropriate valves opened.

3.3 Adding a Cylinder of Premix Gas

The premix tank should be vacuum connected to the swagelock premix port on the laser. Copper or Stainless steel 1/4" tubing must be used to connect the gas regulator to the laser gas port. Using plastic or Teflon tubing will result in reduced laser output energy and gas lifetime. This is the **lower** port when looking from the side of the laser. The swagelock nuts must be tightened securely to avoid vacuum leaks. The internal pump should be switched on using a 1.5-2 second gas pulse from inside the laser to insure pump start. The premix and pump valves should then be opened. This action allows the premix line and the regulator to be pumped out. Pump the line out for 20 minutes. The line should then be flushed. Leaving the pump running, close the valve between the gas regulator and the vacuum line and open the premix cylinder valve, this should bring gas pressure to the high side of the regulator. Next adjust the regulator to bring the low side pressure up to 45 PSI. The cylinder valve must then be closed. Now open the gas valve between the regulator and the vacuum line and allow the gas to be pumped out of the regulator. Repeat this procedure a twice more for a total of 3 gas flushes, waiting approximately 3 minutes between flushes.

After the final flush open the cylinder valve and bring the regulator up to pressure, then switch of the vacuum pump and close the premix and pump valves. The regulator valve between the regulator and the vacuum pump must now be opened. There should be no gas flow and the pressure in the line should be 45PSI. The premix cylinder attachment is now complete.

STEP BY STEP INSTRUCTIONS FOR ATTACHMENT OF NEW GAS CYLINDER.

1. Attach regulator to gas cylinder, do not forget the lead washer.
2. Attach swagelock tube to gas regulator
3. Attach swagelock tubing to laser premix gas port, the lower port or the furthest left depending upon laser model

4. All gas connections must be tight
5. Power up the laser and the software
6. Go to the ADVANCED screen on the software
7. Locate the PUMP PREMIX LINE control
8. Make certain the premix gas cylinder is shut off at the cylinder, and that the regulator valve is open
9. Click the PUMP PREMIX LINE control button
10. Pump the premix line for 10 minutes.
11. After 10 minutes leave the line pumping, do not touch the software, and close the regulator valve
12. Open the cylinder valve slowly, this will pressurize the gas regulator, CLOSE THE CYLINDER VALVE.
13. The gas regulator is now filled with premix gas and the cylinder valve is closed, OPEN THE REGULATOR VALVE.
14. The laser internal vacuum pump should change tone, the gas line is now being flushed.
15. Wait 1 minute
16. Repeat the flush procedure, CLOSE REGULATOR VALVE and briefly OPEN CYLINDER VALVE, CLOSE CYLINDER VALVE and flush the line.
17. Repeat again
18. The premix line is now pumped out and flushed.
19. On the software click the CLOSE ALL VALVES button
20. Open the CYLINDER VALVE on the gas cylinder.
21. Adjust the gas pressure to 40-43 PSI.
22. The line is now pressurized and ready to use.
23. Go to the REFILL screen.
24. Click the PARTIAL GAS REPLACEMENT button
25. Repeat for a total of 4 times
26. The laser is now refilled and ready for operation.

3.4 Adding a Cylinder of helium Gas

Repeat the above procedure with the Helium cylinder on the center port. Copper or Stainless steel 1/4" tubing must be used to connect the gas regulator to the laser gas port. Using plastic or Teflon tubing will result in reduced laser output energy and gas lifetime. In this case the Helium and pump valve must be opened to pump the Helium line.

3.5 Gas Cylinder Replacement with Internal Vacuum Pump

Once a premix gas tank is attached to the laser the laser gas can be exchanged. It is recommended that the gas always be replaced using the partial gas replacement technique, this prevents most of the laser gas handling system ever dropping below atmospheric pressure, this stops any leaks that may exist letting air into the laser. To accomplish partial gas replacement, the pump must be switched on simultaneously with the pump solenoid valve and the main solenoid valve. The chamber pressure will then be observed to decrease, after approximately 15 seconds the pressure reaches 1500 torr and the valves should be closed and the pump switched off. The premix and main valves must now be opened to bring the chamber pressure back to 2300--2350 torr. This takes 10-15 seconds. When the pressure is in the correct range the premix and main valves may be closed. This completes a single partial gas replacement, 4 partial gas replacements are approximately equal to one complete gas replacement. Depending upon when the laser

was last used one or two partial gas replacements should be sufficient to return the laser to high energy output.



3.6 Changing the Excimer Operating Gas type

It may be necessary at times to change the operating wavelength of the laser for example from ArF to KrF. To do this the excimer laser gas premix cylinder must be changed from an ArF premix cylinder to a KrF premix cylinder. (Optics exchanges may also be required.) The old cylinder must first be shut off at the main cylinder valve, and then the gas line pumped out using the PREMIX LINE PUMP command in the advanced screen of the software. This removes all Fluorine traces from the gas line. The gas regulator valve should then be closed and the regulator disconnected from the premix gas cylinder. The new gas cylinder is then connected to the regulator. Again use the PREMIX LINE PUMP command in software to pump the gas line with the regulator valve open for approximately 10-15 minutes and flush the line by filling the regulator with premix gas with the regulator valve closed. Slightly opening the regulator valve for a few seconds will flush the premix line with premix gas. The PREMIX LINE PUMP command can now be switched off and the regulator valve and cylinder valve opened. The regulator should be set to 40 PSI gauge pressure. The premix line is now pressurized.

The laser should now be pumped out and refilled using the AUTOFILL command. This takes approximately 6 minutes. This removes most of the old gas mixture. Once this is done use the PARTIAL GAS REPLACEMENT command 3 times to flush the chamber. After the third partial refill the laser is ready to use.

NOTE: Changing excimer gas type between Fluorine species can be done routinely, however changing from Fluorine's to Chlorine's and vice versa will require several gas fill and several days of normal operation to obtain maximum power from the laser.

3.7 Fluorine Injection

Some versions of the EX50 laser offer Fluorine injection in order to extend the single fill gas lifetime and to reduce operating costs. The Fluorine injector port is located on the gas port panel and is the topmost 1/4" (6mm) gas port. A special cylinder (mixture shown previously) of 5% must be attached to the injector port and the gas line pumped out as described earlier using the appropriate software controls. Fluorine injection can be toggled ON an OFF from software. The F2 Injector manifold layout is shown above.

3.8 Over Pressure Valve

The laser is fitted with an over pressure check valve. The over pressure valve prevents an over pressure situation occurring in the laser chamber. The over pressure valve will vent if the manifold section is pressured above 60 PSI gauge.

It is recommended that a Halogen filter be connected to the exhaust outlet to prevent low concentration Fluorine escaping to the surrounding area in the case of a premix over pressure.

4 Chamber Exchange

The laser chamber may be exchanged in the field. To carry this out the top cover must be removed from the laser and the manual valve on the laser chamber rotated fully clockwise and tightened to seal the laser chamber. The gas manifold should then be evacuated. After manifold evacuation the laser chamber is ready for removal from the system.

All of the electrical connections to the laser head must be disconnected. These are the temperature sensor, the motor power, the thyatron filament supply and ground connections, the high voltage connection and the thyatron trigger lines. Note: the front panel of the laser must be removed in order to disconnect the thyatron connections.

After all of the electrical connections are removed the laser head can be removed from the system by unscrewing the 4 X 8-32 socket head mounting screws. These screws are located on the underside of the baseplate.

Once the old laser chamber is removed the new chamber can be installed by repeating the above steps in the reverse order.

4.1 Laser Operation From Software

The laser may be operated from the EXLASER Windows 9x or Windows NT software available from GAM LASER INC. The laser may also be operated from a custom interface to the J25 connector located on the rear panel of the laser.

The laser is specified to produce a maximum of 50mJ output energy with KrF. In general this output will be produced at approximately 15kV high voltage setting. The high voltage operating range is from 12.0kV to 16kV. Voltages above 16.4kV are not available since there is a hardware high voltage limit incorporated into the interface card. EXLASER software limits the maximum high voltage to 16kV and limits the operating range.

The maximum repetition rate of the laser depends upon the model. Generally both hardware and software adjustments are set to limit repetition. Consult GAM LASER INC. if this hardware limit requires change.

The EX50/250 and EX50/500 are air cooled lasers and therefore the duty cycle depends upon the ambient temperature conditions. The laser can only operate at maximum repetition rate continuously if room temperature is below 21C (70F). The maximum recommended duty cycle for the long term, several hours, is typically 80% and again depends upon the room temperature. An excess duty cycle will cause a temperature rise at the thermistor located on the laser head. A temperature above 45 degrees C is considered undesirable and the laser must be shut down, with the cooling fans remaining on, if the temperature reaches 50 degrees C or more the laser will automatically **shut down during laser operation.**

5 LASER ELECTRONICS

EX50 CONTROL LINES

J25

PIN		FUNCTION
1	Trigger	Input: Normal Low to high(0-5V) to trigger
2	Immed/Command Charge	Input: Low logic (0V)-Command,High logic (5V)=Immed
3	Solenoid #1 Pump out valve:	Input: Low logic (0V)=Closed, High Logic (5V)=Open
4	Solenoid # 3 Main Valve:	Input: Low logic (0V)=Closed, High Logic (5V)=Open
5	Enable/Reset	Input: 0V to 5V to 0V to reset
6	Motor 1	Input: 0V off 5V on
7		
8	Gas Pressure	Output: 0-5V Out=0-3345 Torr
9	Energy Sensor	Output: 0-5V Out = 0-to max mJ software calibrated 50mJ EX50
10	HV peak	Output: 0-5V Out= 0-20kV
11	+12V	Input: 0-5V = 0-15V
12		
13	Gnd	
14		
15	Solenoid #4 Buffer/Purge valve	
16	Solenoid 2 Fill Valve	Input: Low logic (0V)=Closed, High Logic (5V)=Open
17	Cooling Fan Control	Input Low Logic (0V)=Fans ON, High Logic(5V)=Off
18	Motor 2	Input 0V off 5V on
19		
20		
21	Vacuum pump on/off	Input: Low logic (0V) pump off, High Logic (5V) Pump on
22	Interlock	Output (0) Cover open 5V Closed
23	Status/Summary Fault	Output: Low logic (0V)Ok, 5V=Fault
24	Laser Temperature	Output: 0-5V Out=0-50 Centigrade
25	High Voltage set	Input: 0-5V In=0-20kV HV applied

J15

PIN	PARAMETER	
1		
2	Ext Trig	BNC Input: same as pin 1.
6		
8	Ext. Sync BNC Output:	Input: Low to high(0-5V) Charge, High to low(5V-0) Trigger
9		
10	Ext. trig rtn	
13		
15	Ext Sync out RTN	
3,4,5,7,11,12,14	NC	

5.1 **Brief Description of Control Lines**

Pin1 The line is the laser trigger: - Signals to this pin trigger the laser output. A square wave positive going 5V (logic level high) pulse should be applied to this pin. In command charge operation (Default condition) the rising edge of the pulse triggers command charge of the main storage capacitors, laser firing occurs 2mS later. This line requires a COUNTER OUTPUT from a DIO card.

Pin2 This line selects the power supply mode of operation, command charge or DC charging. Command charge is the default condition with no voltage applied to the input. Application of 5V means that the power supply is always charging the main capacitors as soon as the enable is engaged and the charging voltage level is set. Command charge mode is recommended. This line requires a DIGITAL OUTPUT from a DIO card.

Pin3 This line is one of 4 pins, which control gas handing. A 5V (high logic level) opens the solenoid valve, 0V closes the valve. The valve is normally closed. This particular solenoid valve is the PUMP out valve and must be opened to allow gas to flow from the gas manifold to the vacuum pump. This line requires a DIGITAL OUTPUT from a DIO card.

Pin4 This control line is the MAIN valve and is located between the manifold and the laser chamber, the valve must be open to access the laser chamber for pump out or refill. DIGITAL OUTPUT

Pin5 This control line is the enable/reset control. To enable laser operation this line must have 5V (logic level high) applied to it. Manual interlock is included in the laser head, if the interlock is not engaged then even applying 5V to this line will not enable the laser. This line requires a DIGITAL OUTPUT from a DIO card.

Pin6 This line is called MOTOR 1 and is used in combination with pin 18 MOTOR 2 to control the speed of the internal laser blower. 5V applied to pin 6 switches the blower on at 1/3 speed, 0V the default condition is off. The motor begins to ramp up immediately 5V is applied to this line, the motor takes approximately 4 seconds to come up to speed. Application of 5V to pin 18 rotates the blower at 2/3 speed. Application of 5V to both pin 6 and pin 18 rotates the blower at full speed. The motor should be switched off or to low speed when the laser is not in use to increase bearing lifetime. This line requires a DIGITAL OUTPUT from a DIO card.

Pin7 This line monitors the thyatron filament voltage. 5V out on this is equivalent to 10V filament voltage. The filament voltage is normally in the range 6.0-7.5 V.

Pin8 This line gives the gas pressure in the gas manifold, it is separated from the laser head by the MAIN solenoid valve, however under most conditions this sensor reads the laser chamber pressure. The sensor is calibrated to give approximately 3345 torr at 5V output. The sensor is only accurate at the high end and can not be used to determine vacuum during laser pump out. The sensor can be calibrated by adjusting the preset

resistor on the rear of pressure card in the electronics box. This line requires to be connected to an ANALOG INPUT from a DIO card.

Pin9 This line gives the value of the laser energy, the output is not calibrated and must be calibrated through software and by adjusting the hardware optical output adjust on the rear of the optical card. Typically with GAM software the output is adjusted to give 100mJ at 5V output. This line requires to be connected to an ANALOG INPUT from a DIO card.

Pin10 This line gives the peak of the high voltage charge to the main capacitors. 0 to 5V is 0 to 20kV. The maximum value of 20kV can not be reached with the EX50 unit, a hardware lockout prevents the maximum applied voltage being greater than 16.4kV. Software should be used to set the maximum EX50 applied voltage to 16kV. This line requires an ANALOG INPUT from a DIO card.

Pin11 This pin provides +12V of output 100mA for use in creating a stand alone manual control for the laser.

Pin12

Pin13 This is the Gnd pin to the electronics.

Pin14 External trigger, this pin functions identically to pin 1 and provides an extra trigger line primarily for use as an external trigger.

Pin15 This line is the Solenoid #4 control line, the buffer/purge gas line. The buffer/purge line has an external gas port on the rear of the laser and is generally connected to a tank of Helium for use during optics replacement. This line requires a DIGITAL OUTPUT from a DIO card.

Pin16 This line is solenoid #2 the PREMIX valve. The Premix gas line has an external gas port on the rear of the laser, typically a cylinder of premix gas is connected to this port. This line requires a DIGITAL OUTPUT from a DIO card.

Pin17 This line controls the cooling fans, the default condition, 0V is the fans operating. Logic level high 5V stops cooling fan operation. This line is used to thermally control the laser. A simple software routine can be used in conjunction with the laser temperature to maintain the laser chamber temperature to +/- .1 degree centigrade. The recommended range is +/- .2 since this reduces cooling fan cycling. This line requires a DIGITAL OUTPUT from a DIO card.

Pin18 This line is Motor 2 and in conjunction with the Motor 1 line controls the motor speed. Motor 1 alone gives 1/3 motor speed, Motor 2 alone 2/3 motor speed, Motor 1 and Motor 2 together full motor speed.

Pin19

Pin20 This line controls the vacuum pump, 5V (logic level high) switches the vacuum pump on, 0V switches the vacuum pump off. The internal vacuum pump will not start under vacuum, therefore when using the pump for certain operations, the pump must be prepulsed with gas for 1-2 seconds from the laser chamber. This line requires a DIGITAL OUTPUT from a DIO card.

For example: -

OPERATION	GAS PREPULSE REQUIRED	COMMENTS
Chamber pump out pressure	No	Chamber must be above atmospheric pressure. If it is not, gas must be added till this is so.
Initial Premix line pump out	Yes	
Initial Helium line pump out	Yes	

Pin21 This line indicates whether the cover interlock is engaged, 5V means the cover is engaged, 0V means that the interlock is open. The laser will not allow the high voltage power supply to come on when the interlock is open. This line requires to be connected to an DIGITAL INPUT from a DIO card.

Pin22 This line is used to indicate a power supply fault, 5V on this line indicates that there is a power supply problem, the problem is either, High temperature, or Excessive High voltage. This line requires to be connected to DIGITAL INPUT from a DIO card.

Pin23 This line indicates laser temperature. The temperature is calibrated using the two adjustable resistors on the rear of the interface electronics card in the electronics box. The range 0-5V indicates a temperature range of 0-50 degrees C. The thermistor used to determine the laser temperature is mounted directly on to the laser chamber. This line requires to be connected to an ANALOG INPUT from a DIO card.

Pin24 This line controls the power supply charging voltage. 0-5V output on this line gives 0-20kV charging voltage from the power supply. However the EX50 is hardware locked out to a maximum voltage of 16.4kV, and should be software controlled not to exceed 16kV. This line requires to be connected to an ANALOG OUTPUT from a DIO card.

5.2 Electronics

The EX50 electronics are located in the electronics compartment. Access to the electronics compartment is through the electronics panel on the rear of the laser. The J25 connector is located on the electronics panel. Removal of the 6 button head screws allows access to the electronics. The electronics package consists of 4 function cards, which insert into a motherboard. The 4 cards are; the trigger/command charge card, the pressure card, the optical card and the interface card.



5.3 Command/Trigger Card

The trigger/Command charge card provides the trigger pulse for the thyatron and the timing signals for the high voltage power supply. This pulse is approximately 300V and is connected from the rear of the electronics box to the thyatron by the yellow and black wire pair. The inhibit time of the power supply may be adjusted using the adjustable potentiometer located on the rear of the card. For 500Hz operation this value is set to 2mS for the non inhibit time. The inhibit should be set to the appropriate time depending upon the maximum repetition rate of the laser; 1mS for a 1000Hz laser, 1.33mS for 750Hz, 2mS for 500Hz and 4mS for 250Hz.

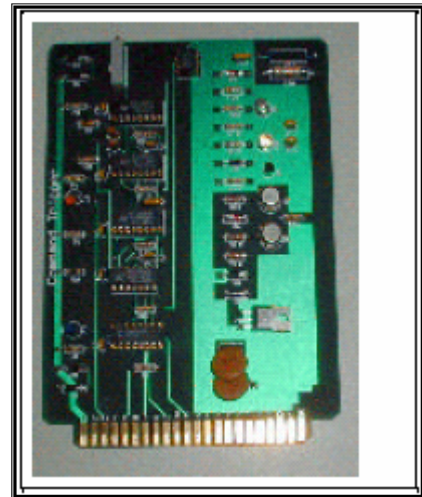

5.4 Pressure/Optical Card

The pressure card controls the solenoid valves and measures the pressure from the pressure sensor located on the laser head. The gain calibration of the pressure sensor can be adjusted by the potentiometer on the pressure card. The optical card measures the signal from the internal detector located at the rear of the laser. The gain of the internal detector can be adjusted and the detector calibrated by adjusting the potentiometer on the optical card. Moving the position of the internal detector, or rotating the 45 degree mirror attached to the rear panel will also result in changes in the detector signal.

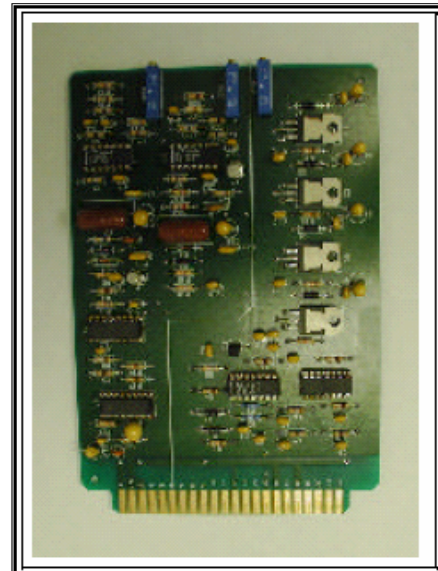

5.5 Interface Card

The interface card handles the signals to and from the computer cards or control box, which operate the laser. Problems with several signals simultaneously may indicate a problem with the interface card. Consult the backplane connection chart to fault find the various signals coming off the interface card. The temperature calibration potentiometers and the blower motor speed control are located on the rear of this card. The two adjustable potentiometer located nearest the 25 pin connector on the interface are used to calibrate the thermistor on the laser chamber. The adjustable potentiometer furthest from the 25 pin connector is used to adjust the maximum motor rotation speed. This potentiometer should be adjusted to **the minimum** motor speed, which allows the specified maximum repetition rate operation on the selected gas, or the maximum required repetition rate for the application. Note that the fan rotates at three speed settings, 1/3, 2/3 and full, the speed adjustment affects the maximum speed in each of the settings.

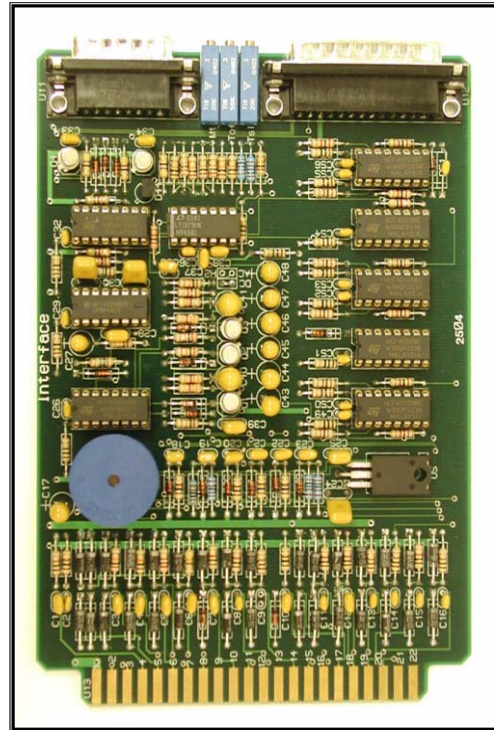

The blower speed may be adjusted by the potentiometer on the interface. An optical tachometer should be used to measure the rotation speed of the external magnetic coupling. The external magnetic coupling has a single reflective portion of tape attached to it for the purpose of rotational speed measurement by an optical tachometer. Use the software motor controls in the ADVANCED screen to operate the motor. The access panel in the top cover must be removed to allow the optical tachometer to reach the external magnetic coupling. Adjust the interface motor potentiometer while observing the external magnetic coupling speed.

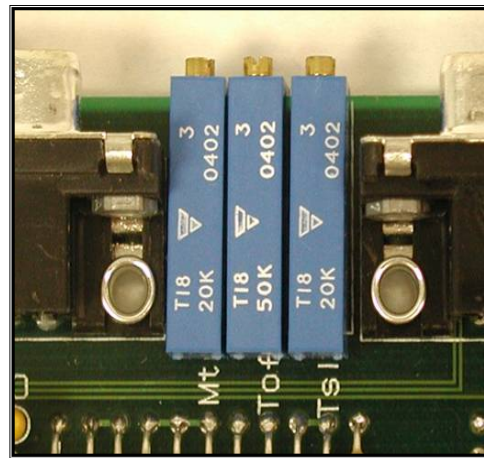

6 TROUBLESHOOTING

WARNING: Connecting a laser to the incorrect line voltage will cause permanent damage to the laser electrical system. Damage can occur when a unit set up or selected for 110V ac operation is connected to a 220V ac line. Connecting a unit set for 220V ac to a 110V ac line will likely cause no permanent damage but may blow fuses.

Problems may occur with the laser from time to time. This section is designed assist in determining the cause of problems and in correcting any problems.

6.1 *Low Energy*

Low energy can be caused by several factors:-

1. Optics misalignment

In the case of optics misalignment the output beam will look asymmetrical. When correctly aligned the beam should have a rectangular appearance. The dimensions should be approx. 12mm X 6mm on a sheet of paper at a distance of 1 meter from the output of the laser.

2. Bad gas or pump out and refill problems.

A major cause of poor laser performance (low output energy and a split laser beam particularly with ArF) is contamination in the laser which occurs during pump out and gas refill. Additionally any small leaks in the premix gas lines will reduce the laser energy. All of the vacuum fittings in the premix line swagelock connection should be tightened until it is **very tight**.

3. Optics contamination or damage.

If the laser has been in use for a large number of pulses, typically more than 100 million with ArF, or hundreds of millions with other gases, then the optics may be contaminated or damaged. In general only the output coupler (front) optics shows damage. If the alignment of the laser is good and the laser has shown a progressive slow decrease in energy over time, then in may be that optics cleaning or replacement is necessary. Clean the optics as described earlier in the manual. Replacement optics can be obtained from GAM LASER INC.

As of January 1999 new optics are used in all new lasers, the new optics provide much increased lifetime, up to 100 million pulses between replacements with ArF. Lasers with old optics should be retrofitted with the new optics when replacement is required. Even with the new optics, cleaning may be required before the 100 million optic lifetime.

4. Bad premix gas.

A bad tank of gas does occur very occasionally, Arf and F2 are most susceptible to bad premix cylinders an indicator of bad gas is that the energy may start off OK and fall very quickly after a refill, typically in a few thousand pulses.

6.2 Laser will not Laser and there is no Discharge

If the laser will not lase and no gas discharge is produced there may be a number of possible problems.

First check that the cover and remote interlocks are enabled. Is there a blue emission indicator light when the unit is commanded to run from software?

The emission indicator light is located on the front panel of the laser. When a trigger signal is applied to pin 1 of the 25 pin connector, or to the external trigger BNC on the rear panel of the laser, the blue light comes on. Failure of the blue light to come on when the laser is controlled to operate means that there is no trigger signal applied to pin 1.

6.3 If there is a blue emission light and the laser still does not fire

Check the high voltage indication V_{peak} , this value will be displayed in software as the high voltage value, this is pin #10 on the main 25 pin connector located on the rear panel of the laser. When the laser is commanded to run, V_{peak} displays the voltage applied to the laser head. If this voltage shows less than 10kV there is a high voltage problem. In software high voltage is displayed in percent terms, the high voltage value must be greater than 60%.

Check the power supply enable line. An enable signal must be supplied on pin 5 of the 25 pin connector on the rear of the laser. Failure to supply an enable signal will cause the high voltage power supply to remain inactive. Also check the power supply inhibit line. This line requires 10V to allow power supply operation. In command charge mode this line pulses to 10V for 2mS and then returns to 0V.

6.4 There is noise when the blower motor starts

Noise from the blower motor may be associated with the external belt, which drives the external magnetic coupling from the motor. If this belt is loose the rotational assembly can become noisy. The belt can be tightened by adjusting the position of the motor, which is mounted by 4 bolts to a motor mount attached to the laser chamber.

ALWAYS SWITCH OFF THE LASER AND DISCONNECT THE LINE CORD WHEN CONDUCTING SERVICE INSIDE THE LASER.

This manual is updated frequently, call GAM LASER INC. for the latest version of this document.

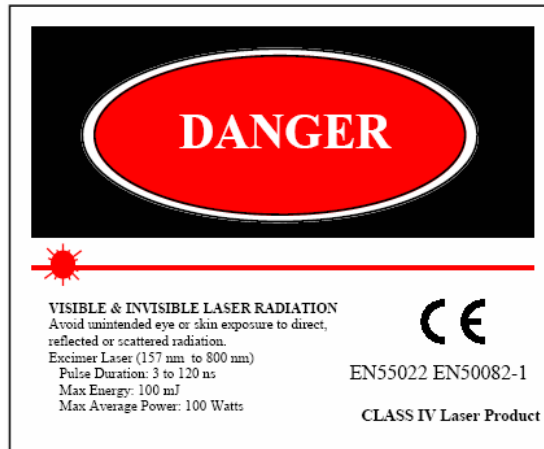

Located on outside cover, left side

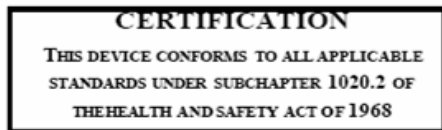

Located on rear panel



Located on front panel aperture

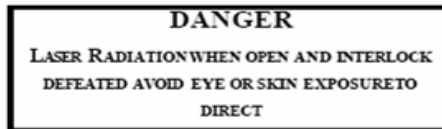

Located on outside, left side

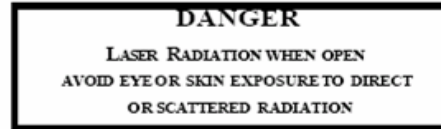

Located on main capacitor bank, internal



Located on rear panel OEM only

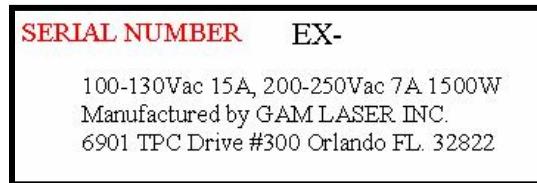

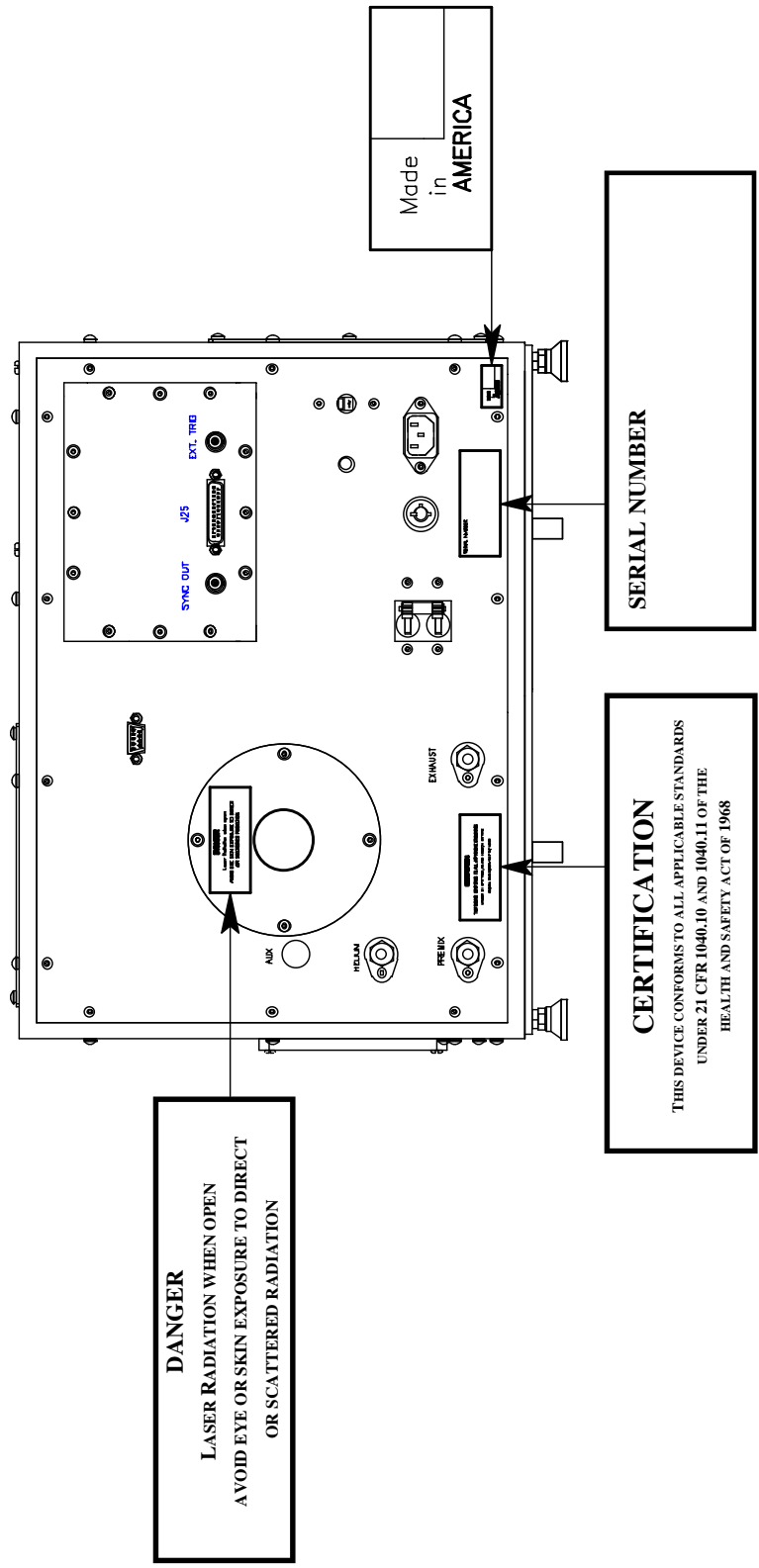

AVOID EXPOSURE
VISIBLE and/or INVISIBLE
LASER RADIATION
EMITTED FROM THIS APERTURE

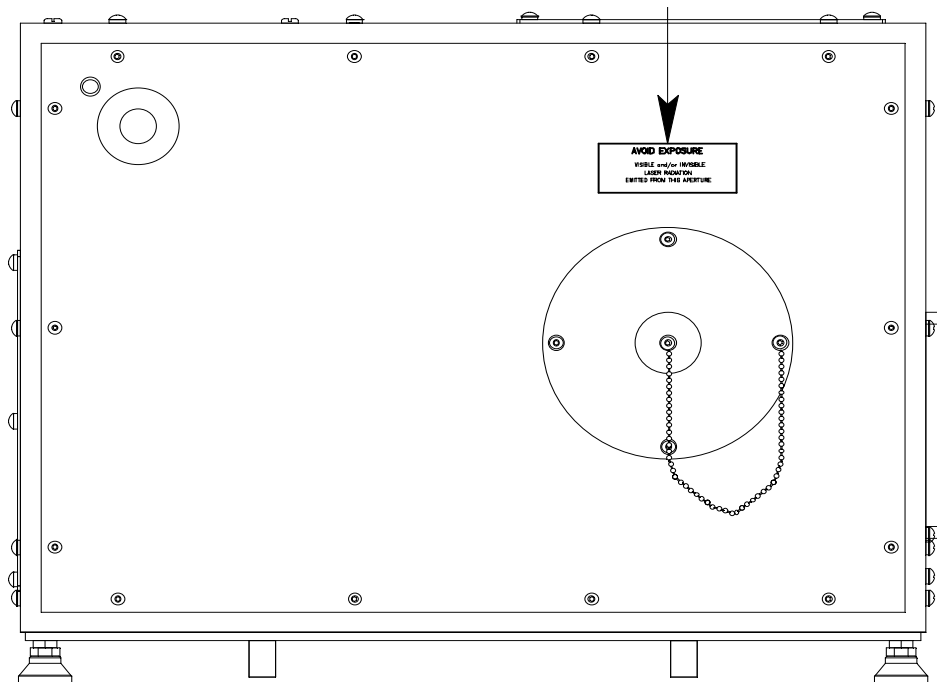

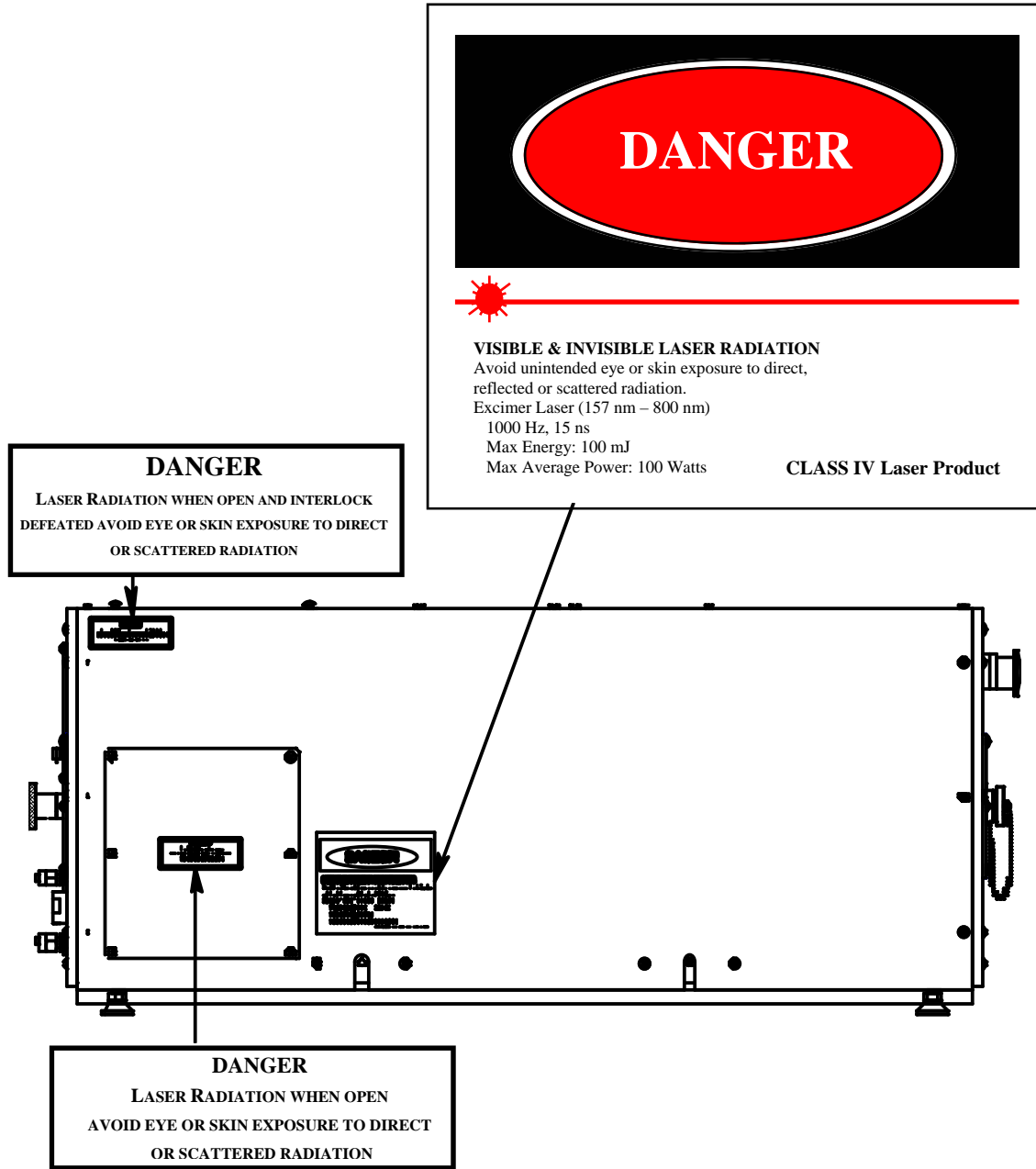

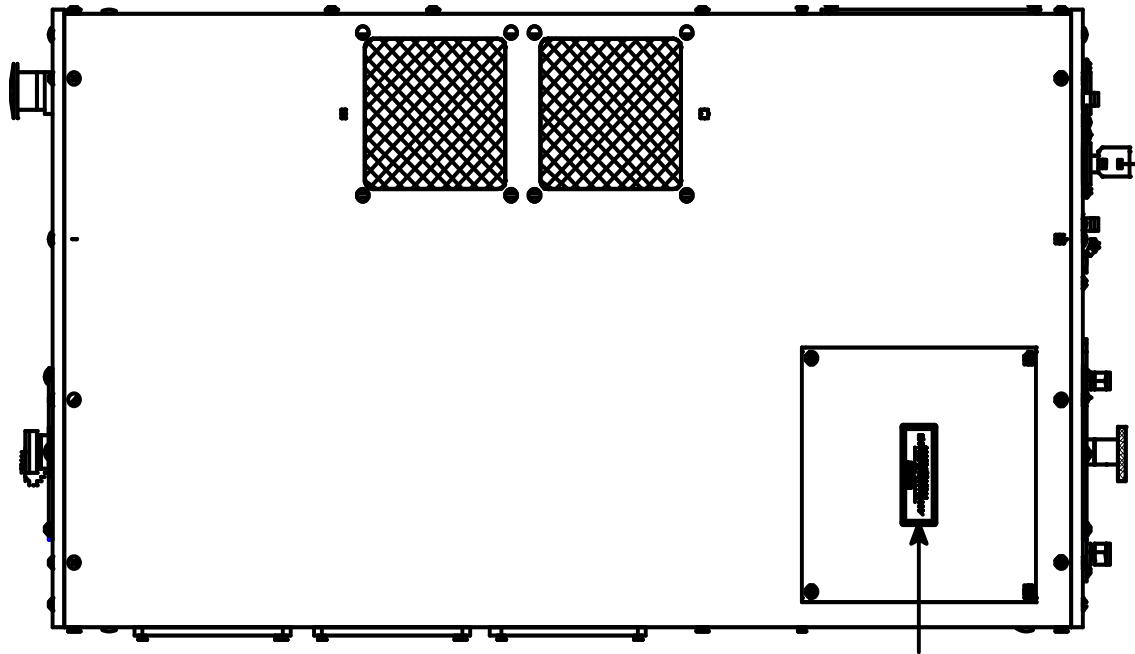

DANGER
LASER RADIATION WHEN OPEN
AVOID EYE OR SKIN EXPOSURE TO DIRECT
OR SCATTERED RADIATION

