

DATA SHEET

PEMH1; PUMH1
NPN/NPN resistor-equipped
transistors; R1 = 22 k Ω , R2 = 22 k Ω

Product specification
Supersedes data of 2001 Oct 22

2003 Oct 08

**NPN/NPN resistor-equipped transistors;
R1 = 22 kΩ, R2 = 22 kΩ**

PEMH1; PUMH1

FEATURES

- Built-in bias resistors
- Simplified circuit design
- Reduction of component count
- Reduced pick and place costs.

APPLICATIONS

- Low current peripheral driver
- Replacement of general purpose transistors in digital applications
- Control of IC inputs.

QUICK REFERENCE DATA

SYMBOL	PARAMETER	TYP.	MAX.	UNIT
V _{CEO}	collector-emitter voltage	–	50	V
I _O	output current (DC)	–	100	mA
TR1	NPN	–	–	–
TR2	NPN	–	–	–
R1	bias resistor	22	–	kΩ
R2	bias resistor	22	–	kΩ

DESCRIPTION

NPN/NPN resistor-equipped transistors (see “Simplified outline, symbol and pinning” for package details).

PRODUCT OVERVIEW

TYPE NUMBER	PACKAGE		MARKING CODE	NPN/PNP COMPLEMENT	PNP/PNP COMPLEMENT
	PHILIPS	EIAJ			
PEMH1	SOT666		H2	PEMD2	PEMB1
PUMH1	SOT363	SC-88	H*2 ⁽¹⁾	PUMD2	PUMB1

Note

- * = p: Made in Hong Kong.
 * = t: Made in Malaysia.
 * = W: Made in China.

SIMPLIFIED OUTLINE, SYMBOL AND PINNING

TYPE NUMBER	SIMPLIFIED OUTLINE AND SYMBOL	PINNING	
		PIN	DESCRIPTION
PEMH1 PUMH1	<p>Top view MHC650</p>	1	emitter TR1
		2	base TR1
		3	collector TR2
		4	emitter TR2
		5	base TR2
		6	collector TR1

NPN/NPN resistor-equipped transistors;
 $R1 = 22\text{ k}\Omega$, $R2 = 22\text{ k}\Omega$

PEMH1; PUMH1

ORDERING INFORMATION

TYPE NUMBER	PACKAGE		
	NAME	DESCRIPTION	VERSION
PEMH1	–	plastic surface mounted package; 6 leads	SOT666
PUMH1	–	plastic surface mounted package; 6 leads	SOT363

LIMITING VALUES

In accordance with the Absolute Maximum Rating System (IEC 60134).

SYMBOL	PARAMETER	CONDITIONS	MIN.	MAX.	UNIT
V_{CBO}	collector-base voltage	open emitter	–	50	V
V_{CEO}	collector-emitter voltage	open base	–	50	V
V_{EBO}	emitter-base voltage	open collector	–	10	V
V_I	input voltage positive negative		–	+40	V
			–	–10	V
I_O	output current (DC)		–	100	mA
I_{CM}	peak collector current		–	100	mA
P_{tot}	total power dissipation SOT363 SOT666	$T_{amb} \leq 25\text{ }^\circ\text{C}$ note 1	–	200	mW
		notes 1 and 2	–	200	mW
T_{stg}	storage temperature		–65	+150	$^\circ\text{C}$
T_j	junction temperature		–	150	$^\circ\text{C}$
T_{amb}	operating ambient temperature		–65	+150	$^\circ\text{C}$
Per device					
P_{tot}	total power dissipation SOT363 SOT666	$T_{amb} \leq 25\text{ }^\circ\text{C}$ note 1	–	300	mW
		notes 1 and 2	–	300	mW

Notes

1. Device mounted on an FR4 printed-circuit board, single-sided copper, standard footprint.
2. Reflow soldering is the only recommended soldering method.

NPN/NPN resistor-equipped transistors;
 $R1 = 22 \text{ k}\Omega$, $R2 = 22 \text{ k}\Omega$

PEMH1; PUMH1

THERMAL CHARACTERISTICS

SYMBOL	PARAMETER	CONDITIONS	VALUE	UNIT
Per transistor				
$R_{th \text{ j-a}}$	thermal resistance from junction to ambient	$T_{amb} \leq 25 \text{ }^\circ\text{C}$		
	SOT363	note 1	625	K/W
	SOT666	notes 1 and 2	625	K/W
Per device				
$R_{th \text{ j-a}}$	thermal resistance from junction to ambient	$T_{amb} \leq 25 \text{ }^\circ\text{C}$		
	SOT363	note 1	416	K/W
	SOT666	notes 1 and 2	416	K/W

Notes

1. Device mounted on an FR4 printed-circuit board, single-sided copper, standard footprint.
2. Reflow soldering is the only recommended soldering method.

CHARACTERISTICS

$T_{amb} = 25 \text{ }^\circ\text{C}$ unless otherwise specified.

SYMBOL	PARAMETER	CONDITIONS	MIN.	TYP.	MAX.	UNIT
I_{CBO}	collector-base cut-off current	$V_{CB} = 50 \text{ V}$; $I_E = 0$	–	–	100	nA
I_{CEO}	collector-emitter cut-off current	$V_{CE} = 30 \text{ V}$; $I_B = 0$	–	–	1	μA
		$V_{CE} = 30 \text{ V}$; $I_B = 0$; $T_j = 150 \text{ }^\circ\text{C}$	–	–	50	μA
I_{EBO}	emitter-base cut-off current	$V_{EB} = 5 \text{ V}$; $I_C = 0$	–	–	180	μA
h_{FE}	DC current gain	$V_{CE} = 5 \text{ V}$; $I_C = 5 \text{ mA}$	60	–	–	
V_{CEsat}	collector-emitter saturation voltage	$I_C = 10 \text{ mA}$; $I_B = 0.5 \text{ mA}$	–	–	150	mV
$V_{i(off)}$	input-off voltage	$I_C = 100 \text{ } \mu\text{A}$; $V_{CE} = 5 \text{ V}$	–	1.1	0.8	V
$V_{i(on)}$	input-on voltage	$I_C = 5 \text{ mA}$; $V_{CE} = 0.3 \text{ V}$	2.5	1.7	–	V
R1	input resistor		15.4	22	28.6	$\text{k}\Omega$
$\frac{R2}{R1}$	resistor ratio		0.8	1	1.2	
C_c	collector capacitance	$I_E = I_e = 0$; $V_{CB} = 10 \text{ V}$; $f = 1 \text{ MHz}$			2.5	pF

NPN/NPN resistor-equipped transistors;
 R1 = 22 kΩ, R2 = 22 kΩ

PEMH1; PUMH1

PACKAGE OUTLINES

Plastic surface mounted package; 6 leads

SOT666

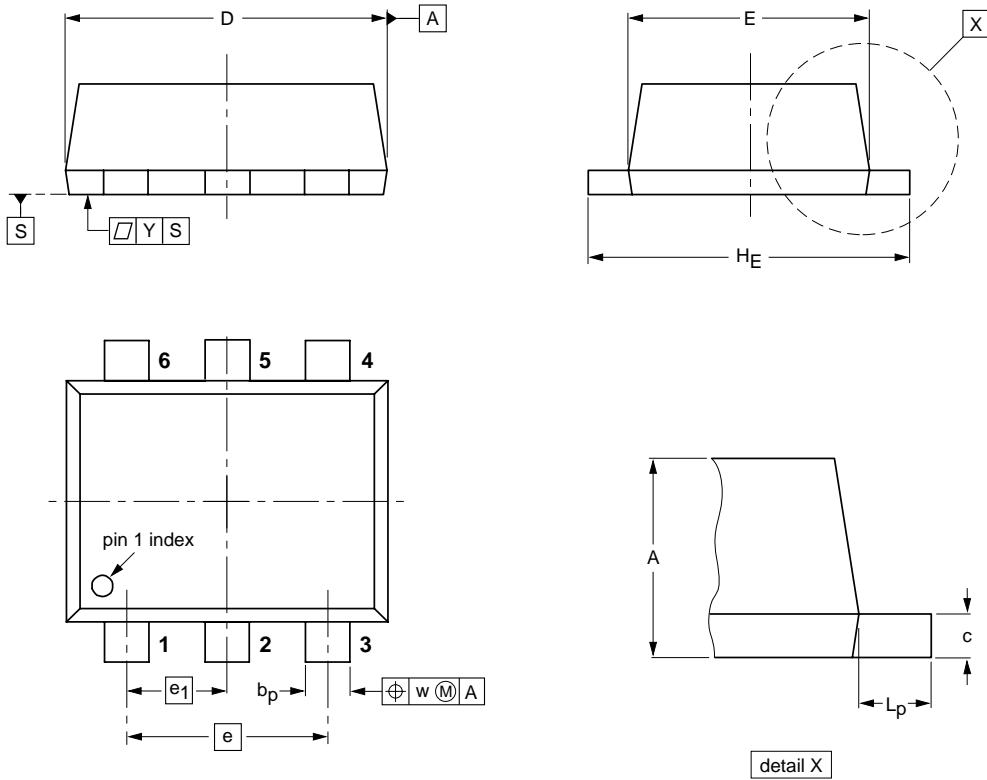

DIMENSIONS (mm are the original dimensions)

UNIT	A	b_p	c	D	E	e	e_1	H_E	L_p	w	y
mm	0.6 0.5	0.27 0.17	0.18 0.08	1.7 1.5	1.3 1.1	1.0	0.5	1.7 1.5	0.3 0.1	0.1	0.1

OUTLINE VERSION	REFERENCES			EUROPEAN PROJECTION	ISSUE DATE
	IEC	JEDEC	EIAJ		
SOT666					01-01-04 01-08-27

NPN/NPN resistor-equipped transistors;
R1 = 22 kΩ, R2 = 22 kΩ

PEMH1; PUMH1

Plastic surface mounted package; 6 leads

SOT363

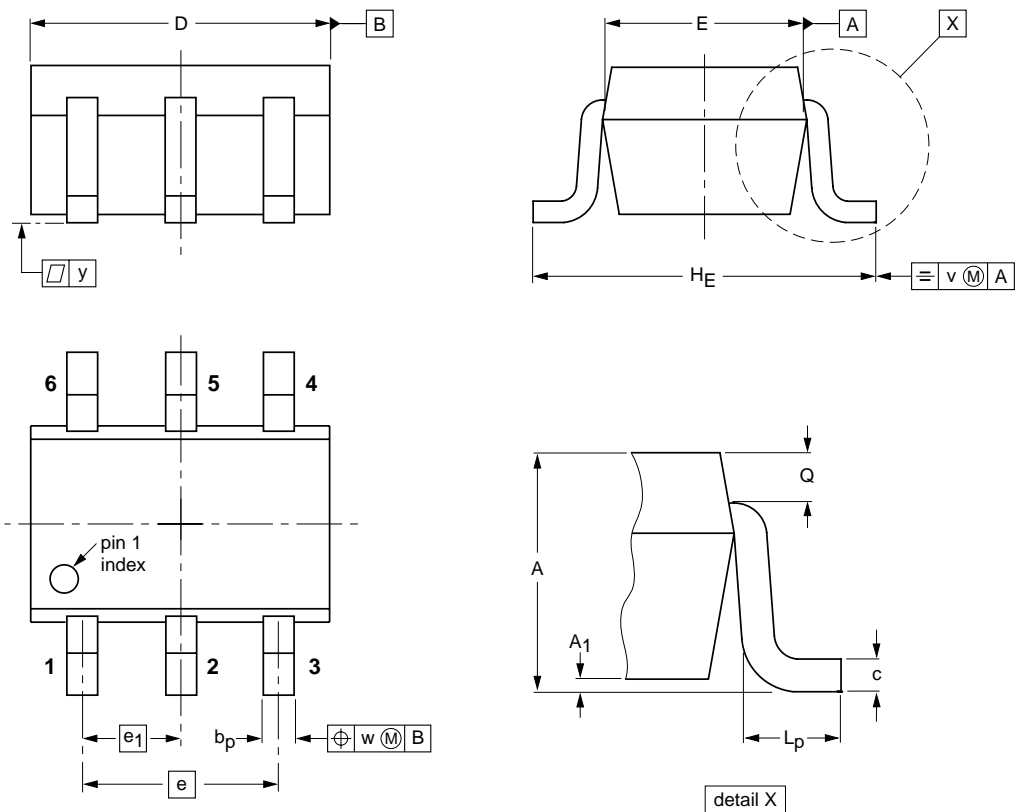

DIMENSIONS (mm are the original dimensions)

UNIT	A	A1 max	bp	c	D	E	e	e1	HE	Lp	Q	v	w	y
mm	1.1 0.8	0.1	0.30 0.20	0.25 0.10	2.2 1.8	1.35 1.15	1.3	0.65	2.2 2.0	0.45 0.15	0.25 0.15	0.2	0.2	0.1

OUTLINE VERSION	REFERENCES				EUROPEAN PROJECTION	ISSUE DATE
	IEC	JEDEC	EIAJ			
SOT363			SC-88			97-02-28

NPN/NPN resistor-equipped transistors;
R1 = 22 k Ω , R2 = 22 k Ω

PEMH1; PUMH1

DATA SHEET STATUS

LEVEL	DATA SHEET STATUS ⁽¹⁾	PRODUCT STATUS ⁽²⁾⁽³⁾	DEFINITION
I	Objective data	Development	This data sheet contains data from the objective specification for product development. Philips Semiconductors reserves the right to change the specification in any manner without notice.
II	Preliminary data	Qualification	This data sheet contains data from the preliminary specification. Supplementary data will be published at a later date. Philips Semiconductors reserves the right to change the specification without notice, in order to improve the design and supply the best possible product.
III	Product data	Production	This data sheet contains data from the product specification. Philips Semiconductors reserves the right to make changes at any time in order to improve the design, manufacturing and supply. Relevant changes will be communicated via a Customer Product/Process Change Notification (CPCN).

Notes

1. Please consult the most recently issued data sheet before initiating or completing a design.
2. The product status of the device(s) described in this data sheet may have changed since this data sheet was published. The latest information is available on the Internet at URL <http://www.semiconductors.philips.com>.
3. For data sheets describing multiple type numbers, the highest-level product status determines the data sheet status.

DEFINITIONS

Short-form specification — The data in a short-form specification is extracted from a full data sheet with the same type number and title. For detailed information see the relevant data sheet or data handbook.

Limiting values definition — Limiting values given are in accordance with the Absolute Maximum Rating System (IEC 60134). Stress above one or more of the limiting values may cause permanent damage to the device. These are stress ratings only and operation of the device at these or at any other conditions above those given in the Characteristics sections of the specification is not implied. Exposure to limiting values for extended periods may affect device reliability.

Application information — Applications that are described herein for any of these products are for illustrative purposes only. Philips Semiconductors make no representation or warranty that such applications will be suitable for the specified use without further testing or modification.

DISCLAIMERS

Life support applications — These products are not designed for use in life support appliances, devices, or systems where malfunction of these products can reasonably be expected to result in personal injury. Philips Semiconductors customers using or selling these products for use in such applications do so at their own risk and agree to fully indemnify Philips Semiconductors for any damages resulting from such application.

Right to make changes — Philips Semiconductors reserves the right to make changes in the products - including circuits, standard cells, and/or software - described or contained herein in order to improve design and/or performance. When the product is in full production (status 'Production'), relevant changes will be communicated via a Customer Product/Process Change Notification (CPCN). Philips Semiconductors assumes no responsibility or liability for the use of any of these products, conveys no licence or title under any patent, copyright, or mask work right to these products, and makes no representations or warranties that these products are free from patent, copyright, or mask work right infringement, unless otherwise specified.

Philips Semiconductors – a worldwide company

Contact information

For additional information please visit <http://www.semiconductors.philips.com>. Fax: +31 40 27 24825

For sales offices addresses send e-mail to: sales.addresses@www.semiconductors.philips.com.

© Koninklijke Philips Electronics N.V. 2003

SCA75

All rights are reserved. Reproduction in whole or in part is prohibited without the prior written consent of the copyright owner.

The information presented in this document does not form part of any quotation or contract, is believed to be accurate and reliable and may be changed without notice. No liability will be accepted by the publisher for any consequence of its use. Publication thereof does not convey nor imply any license under patent- or other industrial or intellectual property rights.

Printed in The Netherlands

R75/04/pp8

Date of release: 2003 Oct 08

Document order number: 9397 750 11869

Let's make things better.

**Philips
Semiconductors**



PHILIPS