

MS type Lower Profile Plug

H/MS Series

Circular connector conforming to MIL-C-5015

PAT.P



Connector Height Comparison

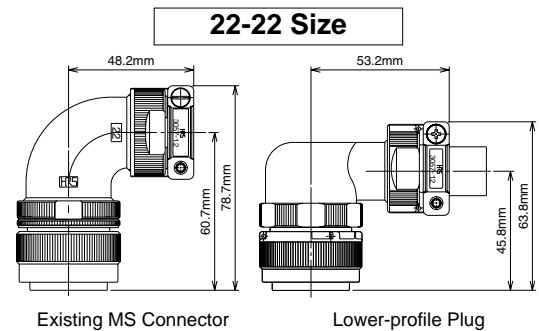
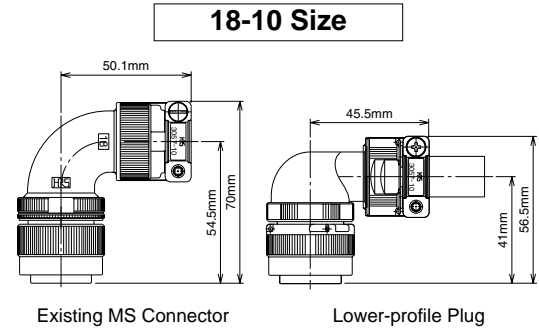

Features

1. 20% Height Reduction

When compared with existing H/MS Series connectors the overall height of plug assemblies is lower, allowing it to be used in space constrained applications.

2. Cable Exit in 360° Directions

The cable can exit in any of the 8 fixed direction, in 45° increments.

3. Simple Assembly

The 2-piece design consisting of the contact/insulator assembly and the back-shell assembly allows termination without the use of any specialized tools.

4. Water and Dust Protection

IP 67 rating when fully terminated and mated with corresponding part.

5. TUV Certification

Provided with a protective circuit function for TUV certification. The (D) pin is directly connected to the outside metal case.

Applications

Factory automation equipment, robotic equipment, servo motors, and a wide variety of industrial and measuring instruments.

Cable Exit Direction of 360°

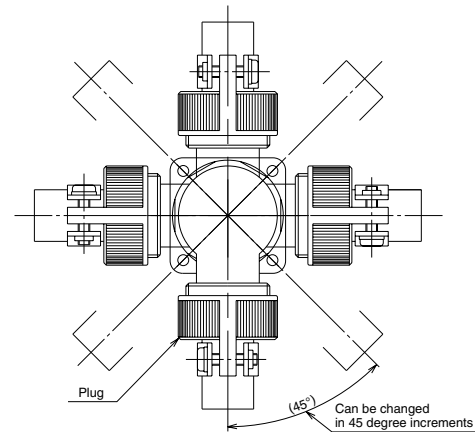

■Product Specifications

Rating	Voltage rating	250VAC, 250V DC (pollution degree: 3, overvoltage category: III) 500V AC, 500V DC (pollution degree: 2, overvoltage category: II)	Operating temperature range -25°C to +125°C
	Current rating	23A Max. (18-10 size) 46A Max. (22-22 size)	Storage temperature range -25°C to +125°C

Item	Specification		Conditions
	18-10 size	22-22 size	
1. Contact resistance	3 m ohms max.	1 m ohms max.	1A DC
2. Insulation resistance	5000 M ohms min.		500 V DC
3. Withstanding voltage	No flashover or insulation breakdown.		2250V AC/one minute.
4. Vibration	No electrical discontinuity for 10 ms max.		Frequency: 10 to 500 Hz, single amplitude of 0.75 mm, acceleration of 98 m/s ² for 3 hours in 3 axis.
5. Shock			Acceleration of 490 m/s ² , 11ms duration, sine half-wave waveform, 3 cycles in each of the 3 axis.
6. Durability (insertion/ withdrawal)	Contact resistance: 4.5 m ohms max.	Contact resistance: 1.5 m ohms max.	500 cycles
7. Temperature cycle	Insulation resistance: 5000 M ohms min.		Temperature: -55°C → Room temperature to +125°C → Room temperature Time: 30 → 10 to 15 → 30 → 10 to 15 (Minutes) 5 cycles.
8. Humidity	Insulation resistance: 50 M ohms min. (Humidity state) 500 M ohms min. (Dry state)		96 hours at temperature of 71°C and humidity of 95% .
9. Water/dust protection	When mated with corresponding connector.		No dust penetration. No water penetration when submerged for 0.5 hour at the depth of 1 meter.

■Materials

Item	Material	Finish	Remarks
Body	Aluminum alloy	Black chromate	—————
Insulator	PPS	Color: Black	UL94V-0
Socket Contacts	Copper alloy	Silver plating	—————
Gasket	Silicone Rubber	Color: Black	—————
Bushing	Chloroprene rubber	Color: Black	—————

■Additional Product Information

1. Product number suffixes

- (10) Supplied with a wire hole in the locking ring (to prevent loosening of the ring).
- (11) Supplied without the wire hole in the locking ring.

2. Corresponding receptacles.

- 18-10 Size: Part number H/MS3102A18-10P-D-T1(10)
- 22-22 Size: Part number H/MS3102A22-22P-D-T(10)

■ Plug

H/MS08A18-10S-DT10D(10)

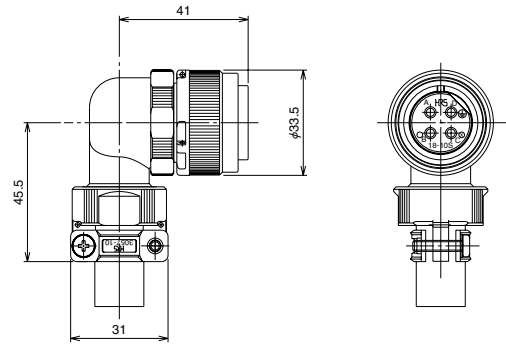

Shown one type.

Part Number	CL No.	Number of Contacts	Weight	Applicable Cable Diameter	Contact solder pot inner diameter
H/MS08A18-10S-DT10D(10)	120-0476-3-10	4	89g	φ12~φ14.3mm	2.5mm
H/MS08A18-10S-DT10D(11)	120-0476-3-11				
H/MS08A18-10S-DT10D1(10)	120-0481-3-10			φ10~φ12.5mm	
H/MS08A18-10S-DT10D1(11)	120-0481-3-10				

H/MS08A18-10S-DT10C(10)

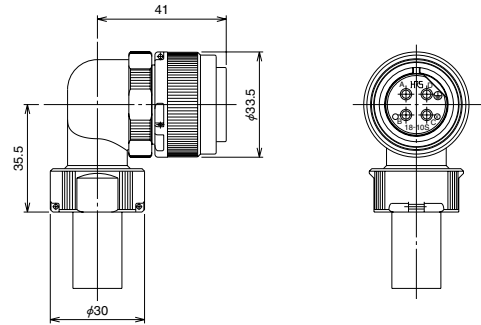

Shown one type.

Part Number	CL No.	Number of Contacts	Weight	Applicable Cable Diameter	Contact solder pot inner diameter
H/MS08A18-10S-DT10C(10)	120-0480-0-10	4	77.6g	φ13~φ14.3mm	2.5mm
H/MS08A18-10S-DT10C(11)	120-0480-0-11				

H/MS08A22-22S-DT12D(10)

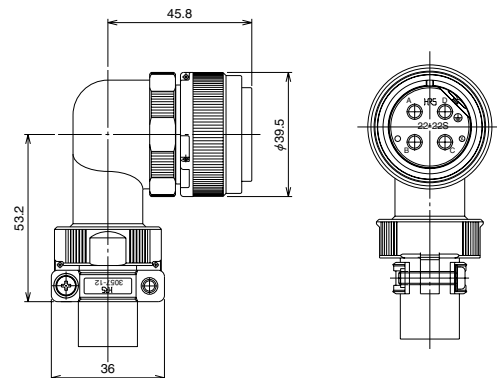

Shown one type.

Part Number	CL No.	Number of Contacts	Weight	Applicable Cable Diameter	Contact solder pot inner diameter
H/MS08A22-22S-DT12D(10)	120-0477-6-10	4	127g	φ13~φ15.9mm	4.5mm
H/MS08A22-22S-DT12D(11)	120-0477-6-11				
H/MS08A22-22S-DT12D1(10)	120-0482-6-10			φ10~φ13.5mm	
H/MS08A22-22S-DT12D1(11)	120-0482-6-11				

◆ Assembly Procedures

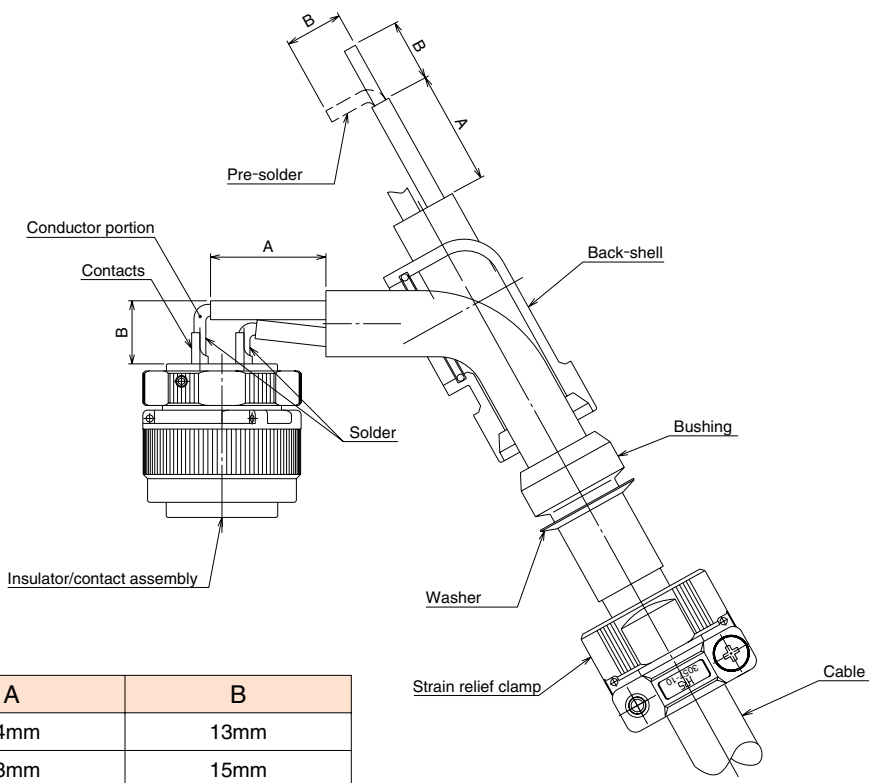
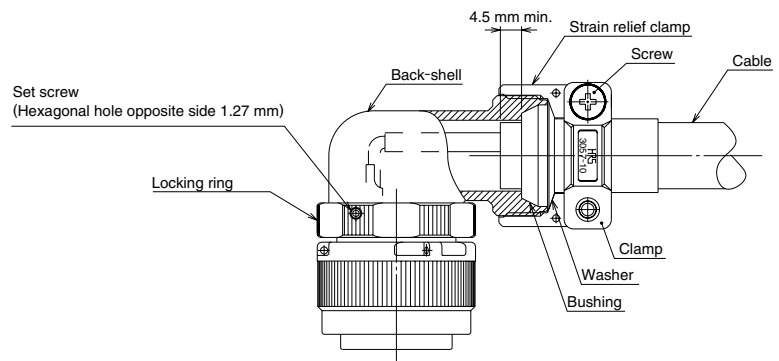
Process	Outline of assembly										
1	 <p>Table 1</p> <table border="1" style="margin-left: auto; margin-right: auto;"> <thead> <tr style="background-color: #f2f2f2;"> <th></th> <th>A</th> <th>B</th> </tr> </thead> <tbody> <tr> <td>18-10 Size</td> <td>24mm</td> <td>13mm</td> </tr> <tr> <td>22-22 Size</td> <td>33mm</td> <td>15mm</td> </tr> </tbody> </table> <p>a. Pass the strain relief clamp, washer, bushing, and hood over the cable, in this order. b. Prepare the cable and conductors per the dimensions in Table 1. c. Bend the exposed conductor to the B dimension as indicated in Table 1. d. Pre-solder the exposed conductor and solder it as shown to the exposed contact. Note: Use care not to damage the conductor's insulation.</p>			A	B	18-10 Size	24mm	13mm	22-22 Size	33mm	15mm
	A	B									
18-10 Size	24mm	13mm									
22-22 Size	33mm	15mm									
2	 <p>Table 2</p> <table border="1" style="margin-left: auto; margin-right: auto;"> <thead> <tr style="background-color: #f2f2f2;"> <th>Locking Ring</th> <th>Cable Clamp</th> </tr> </thead> <tbody> <tr> <td>3 to 3.5N · m</td> <td>5 to 6N · m</td> </tr> </tbody> </table> <p>a. Place over the contact/insulator assembly (in the following order: Back shell, bushing, washer, strain relief clamp). b. Tighten the Locking ring and Cable clamp to the torque values per Table 2. c. Tighten the set screw to a torque value of 0.3-0.4 N·m HRS recommended tool: PB205/1.27 (CL150-0066-3) or equivalent. d. Using screwdriver tighten the two strain relief clamp screws until both sides of the moveable part are in contact with the cable clamp.</p>		Locking Ring	Cable Clamp	3 to 3.5N · m	5 to 6N · m					
Locking Ring	Cable Clamp										
3 to 3.5N · m	5 to 6N · m										



HRS

HIROSE ELECTRIC CO.,LTD.

5-23, OSAKI 5-CHOME, SHINAGAWA-KU, TOKYO 141-8587, JAPAN
 PHONE: 81-3-3491-9741, FAX: 81-3-3493-2933
<http://www.hirose.com>

H/MS SERIES CIRCULAR CONNECTORS COMPLYING WITH JIS B 6015 & MIL GENERAL

■ Scope

The H/MS Series are circular multi-contact connectors meeting the MIL-C-5015 requirements, developed by HIROSE over long years of experience. Connectors complying with TÜV (DIN VDE 0627) and JIS B 6015 (Electric Equipment (electric Equipment for Machine Tools) are not only equipped with protective circuits (grounding terminals), but also compatible with the MS connectors. Thus, the H/MS Series can replace conventional MS connectors easily without any modification on the set side, thus meeting the increasing requirements for safety world-wide.



■ Features

1. Waterproof plugs available
Waterproof plugs are available in L-shaped and straight types. The L-shaped type ensures waterproof mating with the sectioned receptacles. Its waterproof performance satisfies IP67F or more.
2. Waterproof separate receptacle
Receptacles are available in models complying with JIS or not complying with JIS, preventing water from entering. Their waterproof performance exceeds IP67F.
3. Models complying with TÜV and JIS B 6015 are equipped with protective circuits (grounding) During insertion or extraction, the connector is grounded before the other circuits are connected, and disconnected after all other circuits are disconnected. The protective circuit is designed such that it is connected directly to the outer metal case of the connector.
4. Available in a variety of models
Plugs are available in Right Angle or straight types, waterproof or non-waterproof, and complying or not complying with JIS and TÜV.

Material Finish

Part No.	Material	Finish
Shell	Aluminum alloy or zinc alloy	Zinc - plated + OD - colored + Black
Insulator	PPS RESIN, PBT, SIR, NBR	(Black)
Male terminal	Copper alloy	Silver-plated
Female terminal	Copper alloy	Silver-plated

Ordering Information

● Plug & receptacle

H/MSA 3102 A 18 - 10 P X - D - T (01)

-
- (1) Model
 - (2) Form
 - (3) Construction
 - (4) Shell size
 - (5) Terminal arrangement
 - (6) Terminal shape
 - (7) Changes in inserting position against standard model
 - (8) Grounding-terminal number
 - (9) Parts approved by TÜV
 - (11) Other specifications

● Clamp

H/MSA 3057 - 4A (01)

-
- (1) Model
 - (2) Form
 - (10) Clamp size
 - (11) Other specifications

- (1) Model:
H/MS Series
H/MS: Waterproof
H/MSA: Non-waterproof
- (2) Form:
Connector forms are classified as follows:
3102: Receptacle
3106: Straight plug
3108: Right angle plug
3057: Cord clamp
- (3) Construction:
Stands for connector construction
A: Integrated shell
B: Sectioned shell
- (4) Shell size:
Represented by the nominal diameter (in inches) of thread at mating portion multiplied by 16.
Example: A shell with the nominal thread diameter of 1-1/8 inches in called "18" in size. 1-1/8 x 16 = 18 (size 18)
- (5) Terminal arrangement:
See page 184.
- (6) Terminal shape:
Represented as follows.
P: Solder male terminal
S: Solder female terminal
PC: Crimp male terminal
- (7) Changes in inserting position against standard model:
Represented by W, X, Y, or Z. For details, see the Table on page 181.
- (8) Grounding-terminal number:
Represented by C, D, G, and N standing for the numbers of grounding terminals of the connectors complying with JIS. The terminal numbers vary depending on shell size. Product numbers without symbols have no grounding terminal.
- (9) Parts approved by TÜV:
Inhibits parts approved by TÜV corresponding to DIN VDE 0627.
- (10) Clamp size:
Stands for the size and construction of clamps.
- (11) Other specifications:
Any change to the above specifications will be shown by a two-digit numeric suffix (01), (02),

■ Straight Plug

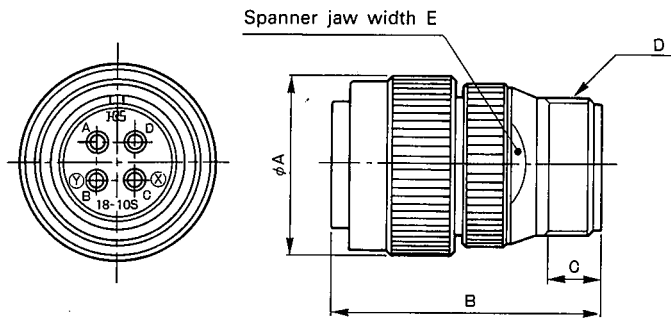
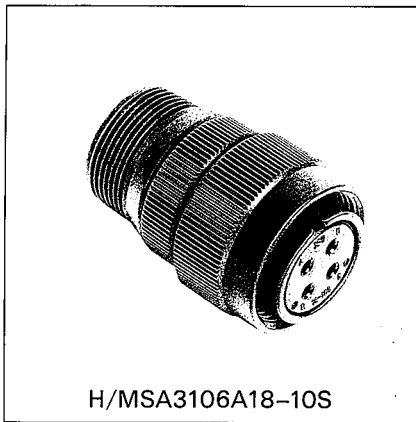

(An example in shape)

HRS No.	Part No.	No. of pins	ϕA	B	C	D	E	Remarks
120-0651-1	H/MSA3106A10SL-4S	2	22	36.8	10	5/8-24UNEF-2A	—	
120-0653-7	H/MSA3106A10SL-3S	3	22	36.8	10	5/8-24UNEF-2A	—	
120-0653-7-10	H/MSA3106A10SL-3S(10)	3	22	36.8	10	5/8-24UNEF-2A	—	Black
120-0655-2	H/MSA3106A18-10S	4	33.5	50	10	1-20UNEF-2A	27	
120-0655-2-10	H/MSA3106A18-10S(10)	4	33.5	50	10	1-20UNEF-2A	27	Black
120-0657-8	H/MSA3106A18-12S	6	33.5	50	10	1-20UNEF-2A	27	
120-0659-3	H/MSA3106A20-15S	7	37	54.5	10	1 3/16-18UNEF-2A	32	
120-0661-5	H/MSA3106A20-29S	17	37	54.5	10	1 3/16-18UNEF-2A	32	
120-0661-5-01	H/MSA3106A20-29SW(01)	17	37	54.5	10	1 3/16-18UNEF-2A	32	
120-0661-5-11	H/MSA3106A20-29SW(11)	17	37	54.5	10	1 3/16-18UNEF-2A	32	Black
120-0663-0	H/MSA3106A22-14S	19	39.5	54.5	10	1 3/16-18UNEF-2A	32	
120-0665-6	H/MSA3106A22-22S	4	39.5	54.5	10	1 3/16-18UNEF-2A	32	
120-0665-6-10	H/MSA3106A22-22S(10)	4	39.5	54.5	10	1 3/16-18UNEF-2A	32	Black
120-0667-1	H/MSA3106A22-23S	8	39.5	54.5	10	1 3/16-18UNEF-2A	32	
120-0669-7	H/MSA3106A24-10S	7	43	57.7	10	1 7/16-18UNEF-2A	37	
120-0669-7-10	H/MSA3106A24-10S(10)	7	43	57.7	10	1 7/16-18UNEF-2A	37	Black

■ Straight Plug

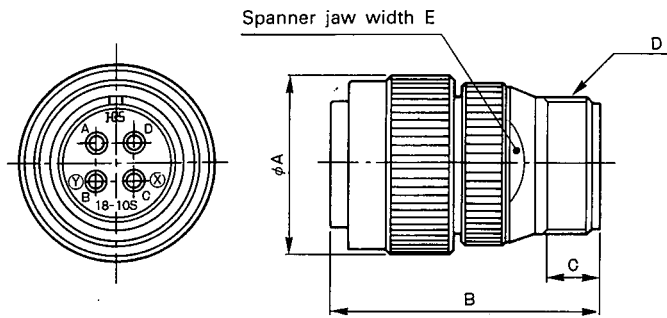
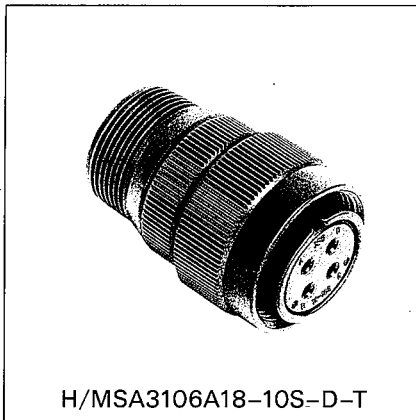

(An example in shape)

[Parts approved by TÜV]

HRS No.	Part No.	No. of pins	ϕ A	B	C	D	E	Remarks
120-0370-2	H/MSA3106A10SL-3S-C-T	3	22	36.8	10	5/8-24UNEF-2A	—	
120-0370-2-10	H/MSA3106A10SL-3S-C-T(10)	3	22	36.8	10	5/8-24UNEF-2A	—	Black
120-0371-5	H/MSA3106A18-10S-D-T	4	33.5	50	10	1-20UNEF-2A	27	
120-0371-5-10	H/MSA3106A18-10S-D-T(10)	4	33.5	50	10	1-20UNEF-2A	27	Black
120-0372-8	H/MSA3106A22-22S-D-T	4	39.5	54.5	10	1 3/16-18UNEF-2A	32	
120-0372-8-10	H/MSA3106A22-22S-D-T(10)	4	39.5	54.5	10	1 3/16-18UNEF-2A	32	Black

■ Straight Plug (Waterproof Type)

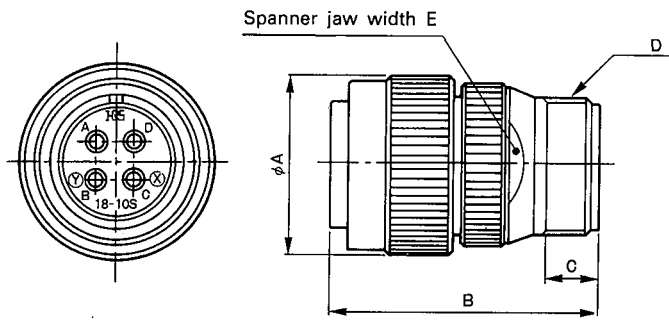
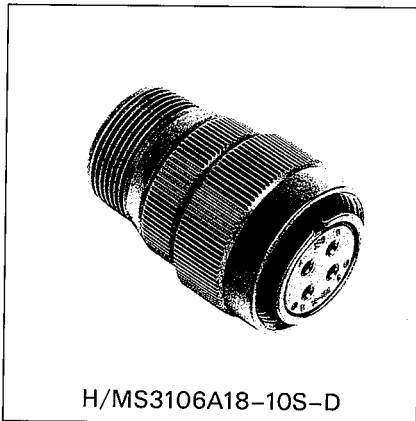

(An example in shape)

HRS No.	Part No.	No. of pins	ϕA	B	C	D	E	Remarks
120-0601-3	H/MS3106A10SL-4S	2	22	36.8	10	5/8-24UNEF-2A	—	
120-0603-9	H/MS3106A10SL-3S	3	22	36.8	10	5/8-24UNEF-2A	—	
120-0603-9-10	H/MS3106A10SL-3S(10)	3	22	36.8	10	5/8-24UNEF-2A	—	Black
120-0605-4	H/MS3106A18-10S	4	33.5	50	10	1-20UNEF-2A	27	
120-0605-4-10	H/MS3106A18-10S(10)	4	33.5	50	10	1-20UNEF-2A	27	Black
120-0607-0	H/MS3106A18-12S	6	33.5	50	10	1-20UNEF-2A	27	
120-0609-5	H/MS3106A20-15S	7	37	54.5	10	1 3/16-18UNEF-2A	32	
120-0611-7	H/MS3106A20-29S	17	37	54.5	10	1 3/16-18UNEF-2A	32	
120-0611-7-01	H/MS3106A20-29SW(01)	17	37	54.5	10	1 3/16-18UNEF-2A	32	
120-0611-7-11	H/MS3106A20-29SW(11)	17	37	54.5	10	1 3/16-18UNEF-2A	32	Black
120-0613-2	H/MS3106A22-14S	19	39.5	54.5	10	1 3/16-18UNEF-2A	32	
120-0615-8	H/MS3106A22-22S	4	39.5	54.5	10	1 3/16-18UNEF-2A	32	
120-0615-8-10	H/MS3106A22-22S(10)	4	39.5	54.5	10	1 3/16-18UNEF-2A	32	Black
120-0617-3	H/MS3106A22-23S	8	39.5	54.5	10	1 3/16-18UNEF-2A	32	
120-0619-9	H/MS3106A24-10S	7	43	57.7	10	1 7/16-18UNEF-2A	37	
120-0619-9-10	H/MS3106A24-10S(10)	7	43	57.7	10	1 7/16-18UNEF-2A	37	Black

■ Straight Plug (Waterproof Type)

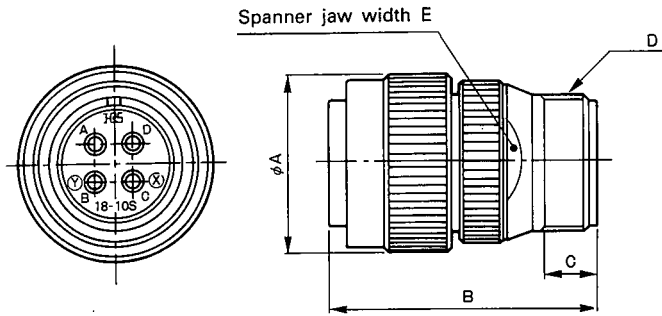
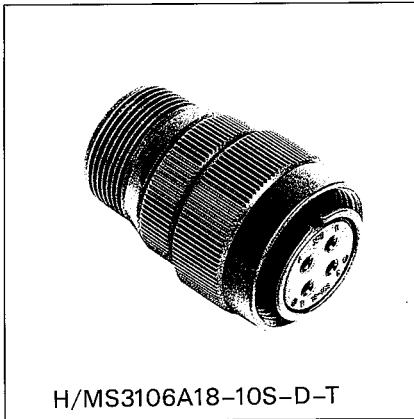

(An example in shape)

[Parts approved by TÜV]

HRS No.	Part No.	No. of pins	ϕA	B	C	D	E	Remarks
120-0326-0	H/MS3106A10SL-3S-C-T	3	22	36.8	10	5/8-24UNEF-2A	—	
120-0326-0-10	H/MS3106A10SL-3S-C-T(10)	3	22	36.8	10	5/8-24UNEF-2A	—	Black
120-0323-2	H/MS3106A18-10S-D-T	4	33.5	50	10	1-20UNEF-2A	27	
120-0323-2-10	H/MS3106A18-10S-D-T(10)	4	33.5	50	10	1-20UNEF-2A	27	Black
120-0324-5	H/MS3106A22-22S-D-T	4	39.5	54.5	10	1 3/16-18UNEF-2A	32	
120-0324-5-10	H/MS3106A22-22S-D-T(10)	4	39.5	54.5	10	1 3/16-18UNEF-2A	32	Black
120-0325-8	H/MS3106A24-10S-G-T	7	43	57.7	10	1 7/16-18UNEF-2A	37	
120-0325-8-10	H/MS3106A24-10S-G-T(10)	7	43	57.7	10	1 7/16-18UNEF-2A	37	Black

■ Right-Angle Plug

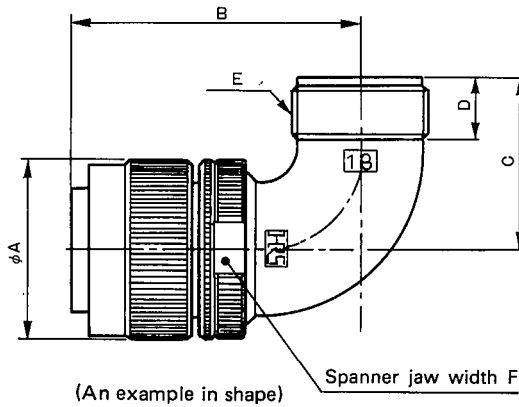
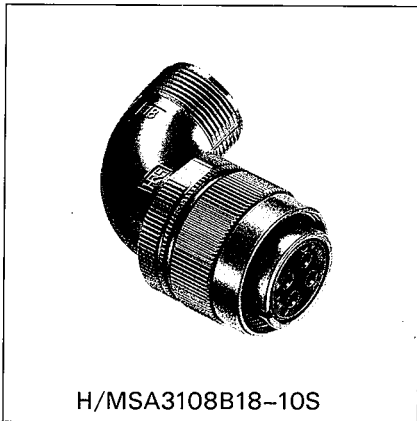

HRS No.	Part No.	No. of pins	φA	B	C	D	E	F	Remarks
120-0751-6	H/MSA3108B10SL-4S	2	22	37.3	24.5	11.6	5/8-24UNEF-2A	20	
120-0753-1	H/MSA3108B10SL-3S	3	22	37.3	24.5	11.6	5/8-24UNEF-2A	20	
120-0753-1-10	H/MSA3108B10SL-3S(10)	3	22	37.3	24.5	11.6	5/8-24UNEF-2A	20	Black
120-0755-7	H/MSA3108B18-10S	4	33.5	54.5	32	11.6	1-20UNEF-2A	32	
120-0755-7-10	H/MSA3108B18-10S(10)	4	33.5	54.5	32	11.6	1-20UNEF-2A	32	Black
120-0757-2	H/MSA3108B18-12S	6	33.5	54.5	32	11.6	1-20UNEF-2A	32	
120-0761-0	H/MSA3108B20-29S	17	37	60.7	34	11.6	1 3/16-18UNEF-2A	35	
120-0761-0-01	H/MSA3108B20-29SW(01)	17	37	60.7	34	11.6	1 3/16-18UNEF-2A	35	
120-0761-0-11	H/MSA3108B20-29SW(11)	17	37	60.7	34	11.6	1 3/16-18UNEF-2A	35	Black
120-0763-5	H/MSA3108B22-14S	19	39.5	60.7	34	11.6	1 3/16-18UNEF-2A	38	
120-0765-0	H/MSA3108B22-22S	4	39.5	60.7	34	11.6	1 3/16-18UNEF-2A	38	
120-0765-0-10	H/MSA3108B22-22S(10)	4	39.5	60.7	34	11.6	1 3/16-18UNEF-2A	38	Black
120-0767-6	H/MSA3108B22-23S	8	39.5	60.7	34	11.6	1 3/16-18UNEF-2A	38	
120-0769-1	H/MSA3108B24-10S	7	43	67.1	39.6	11.6	1 7/16-18UNEF-2A	41	
120-0769-1-10	H/MSA3108B24-10S(10)	7	43	67.1	39.6	11.6	1 7/16-18UNEF-2A	41	Black

■ Right-Angle Plug

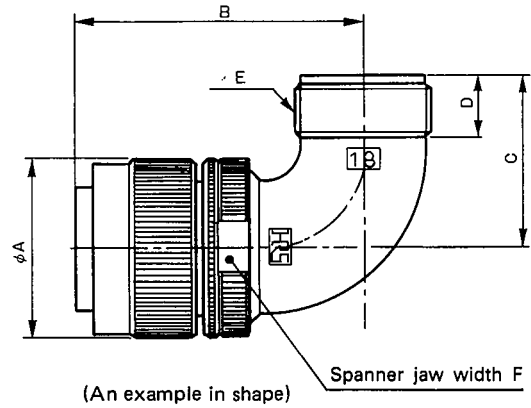
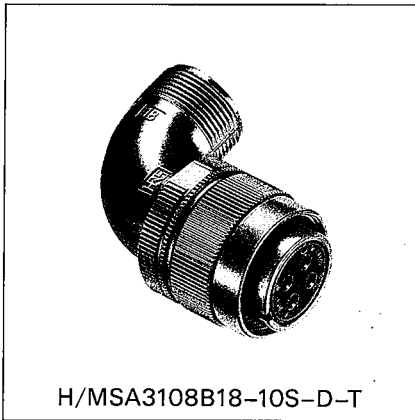

[Parts approved by TÜV]

HRS No.	Part No.	No. of pins	ϕA	B	C	D	E	F	Remarks
120-0471-0	H/MSA3108B18-10S-D-T	4	33.5	54.5	32	11.6	1-20UNEF-2A	32	
120-0471-0-10	H/MSA3108B18-10S-D-T(10)	4	33.5	54.5	32	11.6	1-20UNEF-2A	32	Black

■ Right-Angle Plug (Waterproof Type)

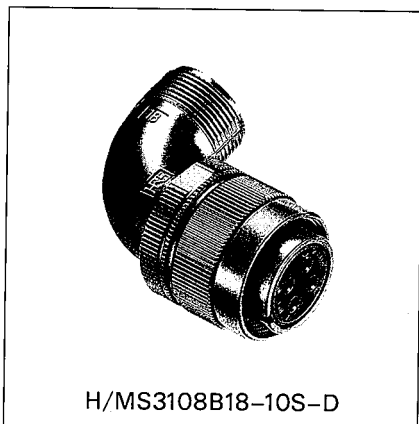

H/MS3108B18-10S-D

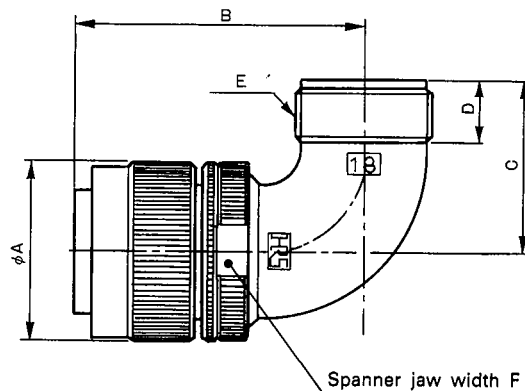

(An example in shape)

HRS No.	Part No.	No. of pins	φA	B	C	D	E	F	Remarks
120-0701-8	H/MS3108B10SL-4S	2	22	37.3	24.5	11.6	5/8-24UNEF-2A	20	
120-0703-3	H/MS3108B10SL-3S	3	22	37.3	24.5	11.6	5/8-24UNEF-2A	20	
120-0703-3-10	H/MS3108B10SL-3S(10)	3	22	37.3	24.5	11.6	5/8-24UNEF-2A	20	Black
120-0705-9	H/MS3108B18-10S	4	33.5	54.5	32	11.6	1-20UNEF-2A	32	
120-0705-9-10	H/MS3108B18-10S(10)	4	33.5	54.5	32	11.6	1-20UNEF-2A	32	Black
120-0707-4	H/MS3108B18-12S	6	33.5	54.5	32	11.6	1-20UNEF-2A	32	
120-0709-0	H/MS3108B20-15S	7	37	60.7	34	11.6	1 3/16-18UNEF-2A	35	
120-0711-1	H/MS3108B20-29S	17	37	60.7	34	11.6	1 3/16-18UNEF-2A	35	
120-0711-1-01	H/MS3108B20-29SW(01)	17	37	60.7	34	11.6	1 3/16-18UNEF-2A	35	
120-0711-1-11	H/MS3108B20-29SW(11)	17	37	60.7	34	11.6	1 3/16-18UNEF-2A	35	Black
120-0713-7	H/MS3108B22-14S	19	39.5	60.7	34	11.6	1 3/16-18UNEF-2A	38	
120-0715-2	H/MS3108B22-22S	4	39.5	60.7	34	11.6	1 3/16-18UNEF-2A	38	
120-0715-2-10	H/MS3108B22-22S(10)	4	39.5	60.7	34	11.6	1 3/16-18UNEF-2A	38	Black
120-0717-8	H/MS3108B22-23S	8	39.5	60.7	34	11.6	1 3/16-18UNEF-2A	38	
120-0719-3	H/MS3108B24-10S	7	43	67.1	39.6	11.6	1 7/16-18UNEF-2A	41	
120-0719-3-10	H/MS3108B24-10S(10)	7	43	67.1	39.6	11.6	1 7/16-18UNEF-2A	41	Black

■ Right-Angle Plug (Waterproof Type)

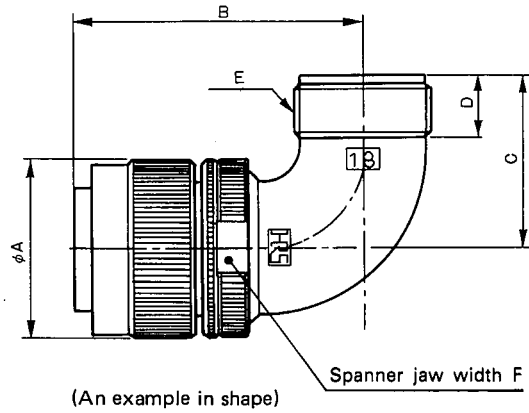
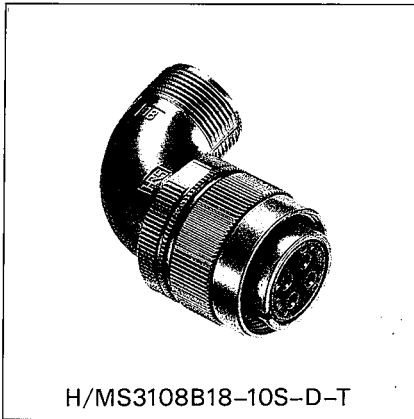

[Parts approved by TÜV]

HRS No.	Part No.	No. of pins	φA	B	C	D	E	F	Remarks
120-0421-1	H/MS3108B10SL-3S-C-T	3	22	37.3	24.5	11.6	5/8-24UNEF-2A	20	
120-0421-1-10	H/MS3108B10SL-3S-C-T(10)	3	22	37.3	24.5	11.6	5/8-24UNEF-2A	20	Black
120-0422-4	H/MS3108B18-10S-D-T	4	33.5	54.5	32	11.6	1-20UNEF-2A	32	
120-0422-4-10	H/MS3108B18-10S-D-T(10)	4	33.5	54.5	32	11.6	1-20UNEF-2A	32	Black
120-0423-7	H/MS3108B22-22S-D-T	4	39.5	60.7	34	11.6	1 3/16-18UNEF-2A	38	
120-0423-7-10	H/MS3108B22-22S-D-T(10)	4	39.5	60.7	34	11.6	1 3/16-18UNEF-2A	38	Black
120-0424-0	H/MS3108B24-10S-G-T	7	43	67.1	39.6	11.6	1 7/16-18UNEF-2A	41	
120-0424-0-10	H/MS3108B24-10S-G-T(10)	7	43	67.1	39.6	11.6	1 7/16-18UNEF-2A	41	Black

■ Separate Unit

Use this unit in combination with connectors for flexible conduit tubes or tough-rubber sheathed cables.

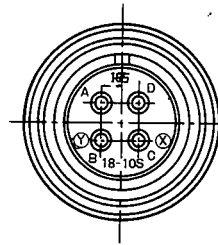

(An example in shape)

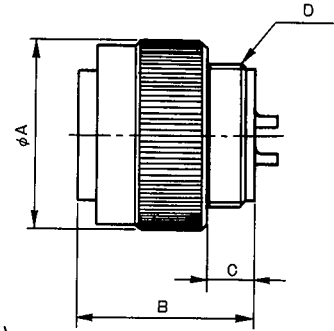

HRS No.	Part No.	No. of pins	ϕ A	B	C	D	Remarks
120-0651-1-03	H/MSA3106A10SL-4S(03)	2	22	24	6.5	9/16-24UNEF-2A	
120-0653-7-03	H/MSA3106A10SL-3S(03)	3	22	24	6.5	9/16-24UNEF-2A	
120-0655-2-03	H/MSA3106A18-10S(03)	4	33.5	31.2	8	1-20UNEF-2A	
120-0659-3-03	H/MSA3106A20-15S(03)	7	37	33.2	10	1 1/8-18UNEF-2A	
120-0661-5-03	H/MSA3106A20-29S(03)	17	37	33.2	10	1 1/8-18UNEF-2A	
120-0663-0-03	H/MSA3106A22-14S(03)	19	39.5	33.2	10	1 1/4-18UNEF-2A	
120-0665-6-03	H/MSA3106A22-22S(03)	4	39.5	33.2	10	1 1/4-18UNEF-2A	
120-0669-7-03	H/MSA3106A24-10S(03)	7	43	34.7	10	1 3/8-18UNEF-2A	

■ Separate Unit

Use this unit in combination with connectors for flexible conduit tubes or tough-rubber sheathed cables.

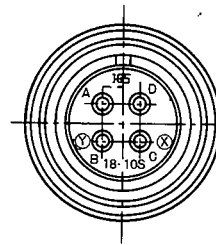

(An example in shape)

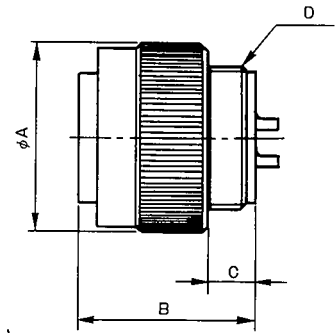

[Parts approved by TÜV]

HRS No.	Part No.	No. of pins	ϕ A	B	C	D	Remarks
120-0370-2-03	H/MSA3106A10SL-3S-C-T(03)	3	22	24	6.5	9/16-24UNEF-2A	
120-0370-2-13	H/MSA3106A10SL-3S-C-T(13)	3	22	24	6.5	9/16-24UNEF-2A	Black
120-0371-5-03	H/MSA3106A18-10S-D-T(03)	4	33.5	31.2	8	1-20UNEF-2A	
120-0371-5-13	H/MSA3106A18-10S-D-T(13)	4	33.5	31.2	8	1-20UNEF-2A	Black
120-0372-8-03	H/MSA3106A22-22S-D-T(03)	4	39.5	33.2	10	1-1/4-18UNEF-2A	
120-0372-8-13	H/MSA3106A22-22S-D-T(13)	4	39.5	33.2	10	1-1/4-18UNEF-2A	Black

■ Separate Unit (Waterproof Type)

Use this unit in combination with connectors for flexible conduit tubes or tough-rubber sheathed cables.

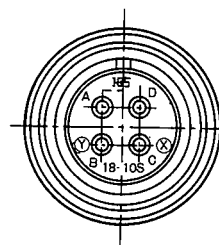

(An example in shape)

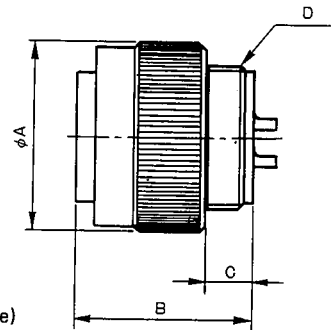

HRS No:	Part No.	No. of pins	ϕA	B	C	D	Remarks
120-0601-3-03	H/MS3106A10SL-4S(03)	2	22	24	6.5	9/16-24UNEF-2A	
120-0603-9-03	H/MS3106A10SL-3S(03)	3	22	24	6.5	9/16-24UNEF-2A	
120-0603-9-13	H/MS3106A10SL-3S(13)	3	22	24	6.5	9/16-24UNEF-2A	Black
120-0605-4-03	H/MS3106A18-10S(03)	4	33.5	31.2	8	1-20UNEF-2A	
120-0605-4-13	H/MS3106A18-10S(13)	4	33.5	31.2	8	1-20UNEF-2A	Black
120-0609-5-03	H/MS3106A20-15S(03)	7	37	33.2	10	1 1/8-18UNEF-2A	
120-0611-7-03	H/MS3106A20-29S(03)	17	37	33.2	10	1 1/8-18UNEF-2A	
120-0611-7-04	H/MS3106A20-29SW(04)	17	37	33.2	10	1 1/8-18UNEF-2A	
120-0611-7-14	H/MS3106A20-29SW(14)	17	37	33.2	10	1 1/8-18UNEF-2A	Black
120-0613-2-03	H/MS3106A22-14S(03)	19	39.5	33.2	10	1 1/4-18UNEF-2A	
120-0615-8-03	H/MS3106A22-22S(03)	4	39.5	33.2	10	1 1/4-18UNEF-2A	
120-0615-8-13	H/MS3106A22-22S(13)	4	39.5	33.2	10	1 1/4-18UNEF-2A	Black
120-0617-3-03	H/MS3106A22-23S(03)	8	39.5	33.2	10	1 1/4-18UNEF-2A	
120-0619-9-03	H/MS3106A24-10S(03)	7	43	34.7	10	1 3/8-18UNEF-2A	
120-0619-9-13	H/MS3106A24-10S(13)	7	43	34.7	10	1 3/8-18UNEF-2A	Black

Separate Unit (Waterproof Type)

Use this unit in combination with connectors for flexible conduit tubes or tough-rubber sheathed cables.

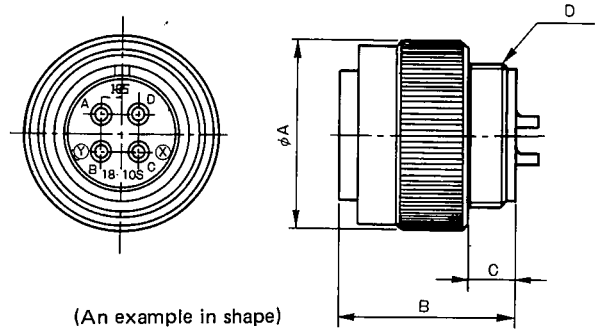

[Parts approved by TÜV]

HRS No.	Part No.	No. of pins	ϕA	B	C	D	Remarks
120-0326-0-03	H/MS3106A10SL-3S-C-T(03)	3	22	24	6.5	9/16-24UNEF-2A	
120-0326-0-13	H/MS3106A10SL-3S-C-T(13)	3	22	24	6.5	9/16-24UNEF-2A	Black
120-0323-2-03	H/MS3106A18-10S-D-T(03)	4	33.5	31.2	8	1-20UNEF-2A	
120-0323-2-13	H/MS3106A18-10S-D-T(13)	4	33.5	31.2	8	1-20UNEF-2A	Black
120-0324-5-03	H/MS3106A22-22S-D-T(03)	4	39.5	33.2	10	1 1/4-18UNEF-2A	
120-0324-5-13	H/MS3106A22-22S-D-T(13)	4	39.5	33.2	10	1 1/4-18UNEF-2A	Black
120-0325-8-03	H/MS3106A24-10S-G-T(03)	7	43	34.7	10	1 3/8-18UNEF-2A	
120-0325-8-13	H/MS3106A24-10S-G-T(13)	7	43	34.7	10	1 3/8-18UNEF-2A	Black

Receptacle

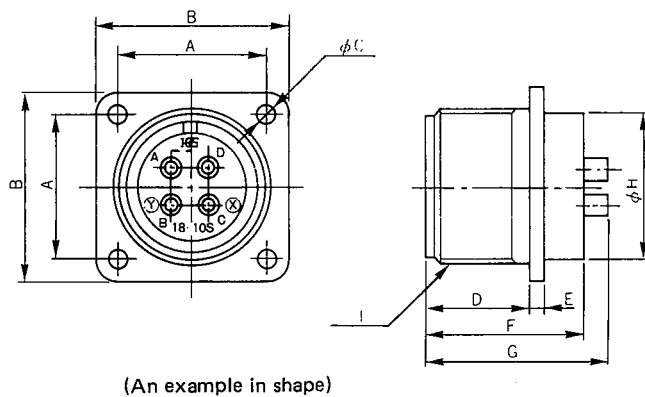
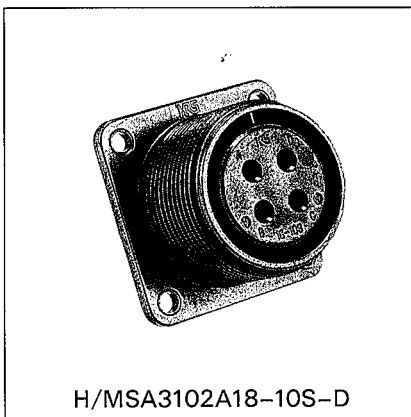

HRS No.	Part No.	No. of pins	A	B	ϕC	D	E	F	G	ϕH	I	Remarks
120-0254-1	H/MSA3102A18-10S-D	4	26.97	34.92	3.3	19.3	2.8	30.7	35.5	26.8	1 1/8-18UNEF-2A	
120-0258-2	H/MSA3102A20-15S-G	7	29.36	38.1	3.3	19.3	2.8	30.7	37.7	29.6	1 1/4-18UNEF-2A	

■ Receptacle (Waterproof Type)

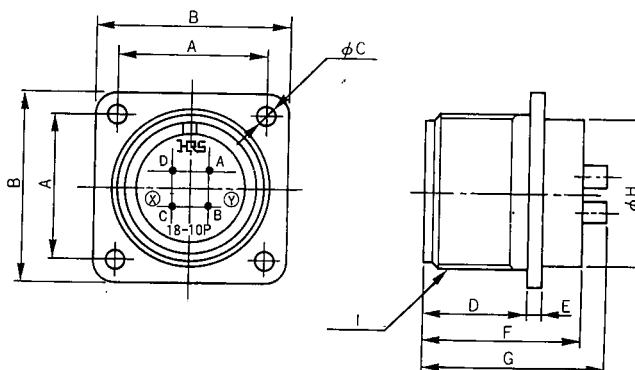
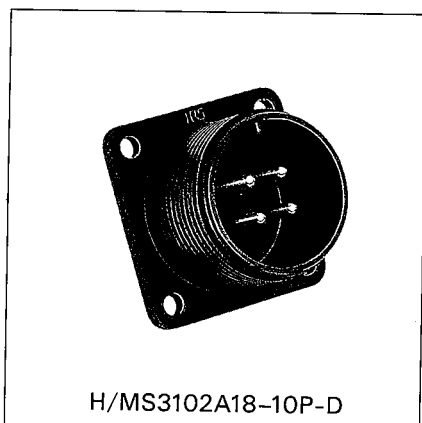

(An example in shape)

HRS No.	Part No.	No. of pins	A	B	φC	D	E	F	G	φH	I	Remarks
* 120-0111-4	H/MS3102A10SL-4P	2	18.26	25.4	3.3	14.5	2.2	23.6	28.3	15.6	5/8-24UNEF-2A	
120-0113-0	H/MS3102A10SL-3P	3	18.26	25.4	3.3	1.45	2.2	23.6	28.3	15.6	5/8-24UNEF-2A	
120-0113-0-10	H/MS3102A10SL-3P(10)	3	18.26	25.4	3.3	14.5	2.2	23.6	28.3	15.6	5/8-24UNEF-2A	Black
120-0101-0	H/MS3102A18-10P	4	26.97	34.92	3.3	19.3	2.8	30	35	26.6	1 1/8-18UNEF-2A	
120-0101-0-10	H/MS3102A18-10P(10)	4	26.97	34.92	3.3	19.3	2.8	30	35	26.6	1 1/8-18UNEF-2A	Black
* 120-0117-0	H/MS3102A18-12P	6	26.97	34.92	3.3	19.3	2.8	30	35	26.6	1 1/8-18UNEF-2A	
120-0115-5	H/MS3102A20-15P	7	29.36	38.1	3.3	19.3	2.8	29.4	35	29.6	1 1/4-18UNEF-2A	
* 120-0103-6	H/MS3102A20-29P	17	29.36	38.1	3.3	19.3	2.8	29.4	33	29.6	1 1/4-18UNEF-2A	
120-0103-6-11	H/MS3102A20-29PW(11)	17	29.36	38.1	3.3	19.3	2.8	29.4	33	29.6	1 1/4-18UNEF-2A	Black
* 120-0105-1	H/MS3102A22-14P	19	31.75	41.28	3.3	19.3	2.8	29.4	33	32.6	1 3/8-18UNEF-2A	
120-0107-7	H/MS3102A22-22P	4	31.75	41.28	3.3	19.3	2.8	29.4	38	32.6	1 3/8-18UNEF-2A	
120-0107-7-10	H/MS3102A22-22P(10)	4	31.75	41.28	3.3	19.3	2.8	29.4	38	32.6	1 3/8-18UNEF-2A	Black
* 120-0119-6	H/MS3102A22-23P	8	31.75	41.28	3.3	19.3	2.8	29.4	35	32.6	1 3/8-18UNEF-2A	
120-0109-2	H/MS3102A24-10P	7	34.92	44.45	3.75	21	2.8	31.6	41	36	1 1/2-18UNEF-2A	
120-0109-2-10	H/MS3102A24-10P(10)	7	34.92	44.45	3.75	21	2.8	31.6	41	36	1 1/2-18UNEF-2A	Black

Note: Models marked with * are available in NBR (acrylonitrile-rubber). Others are available in SIR.

■ Receptacle (Waterproof Type)

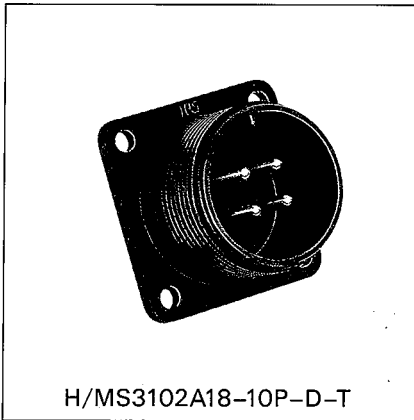

H/MS3102A18-10P-D-T

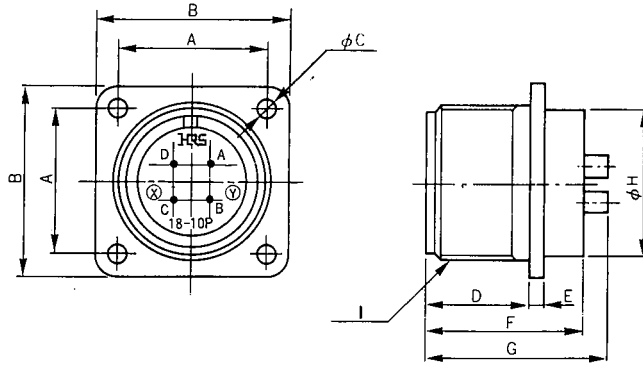

(An example in shape)

[Parts approved by TÜV]

HRS No.	Part No.	No. of pins	A	B	φC	D	E	F	G	φH	I	Remarks
120-0231-6	H/MS3102A10SL-3P-C-T	3	18.26	25.4	3.3	14.5	2.2	23.6	28.3	15.6	5/8-24UNEF-2A	
120-0231-6-10	H/MS3102A10SL-3P-C-T(10)	3	18.26	25.4	3.3	14.5	2.2	23.6	28.3	15.6	5/8-24UNEF-2A	Black
120-0226-6	H/MS3102A18-10P-D-T	4	26.97	34.92	3.3	19.3	2.8	30	35	26.6	1 1/8-18UNEF-2A	
120-0226-6-10	H/MS3102A18-10P-D-T(10)	4	26.97	34.92	3.3	19.3	2.8	30	35	26.6	1 1/8-18UNEF-2A	Black
120-0227-9	H/MS3102A22-22P-D-T	4	31.75	41.28	3.3	19.3	2.8	29.4	38	32.6	1 3/8-18UNEF-2A	
120-0227-9-10	H/MS3102A22-22P-D-T(10)	4	31.75	41.28	3.3	19.3	2.8	29.4	38	32.6	1 3/8-18UNEF-2A	Black
120-0228-1	H/MS3102A24-10P-G-T	7	34.92	44.45	3.75	21	2.8	31.6	41	36	1 1/2-18UNEF-2A	
120-0228-1-10	H/MS3102A24-10P-G-T(10)	7	34.92	44.45	3.75	21	2.8	31.6	41	36	1 1/2-18UNEF-2A	Black

■ Straight Plug

(Crimp Type)

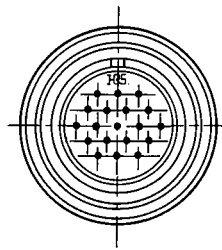

(An example in shape)

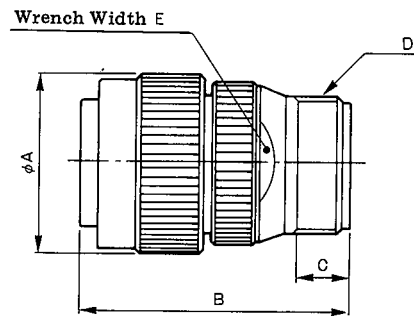

HRS No.	Part No.	No. of pins	ϕA	B	C	D	E	Remarks
120-1661-0	H/MSA3106A20-29SC	17	37	54.5	10	1 3/16-18UNEF-2A	32	
120-1663-6	H/MSA3106A22-14SC	19	39.5	54.5	10	1 3/16-18UNEF-2A	32	

■ Straight Plug (Waterproof Type)

(Crimp Type)

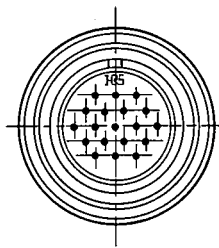

(An example in shape)

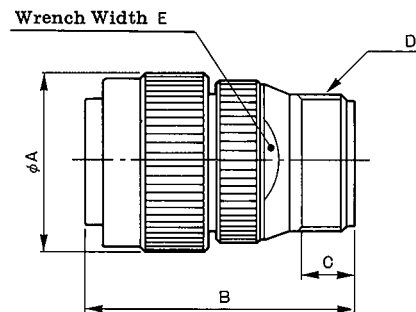

HRS No.	Part No.	No. of pins	ϕA	B	C	D	E	Remarks
120-1611-2	H/MS3106A20-29SC	17	37	54.5	10	1 3/16-18UNEF-2A	32	
120-1613-8	H/MS3106A22-14SC	19	39.5	54.5	10	1 3/16-18UNEF-2A	32	

■ Right-Angle Plug

(Crimp Type)

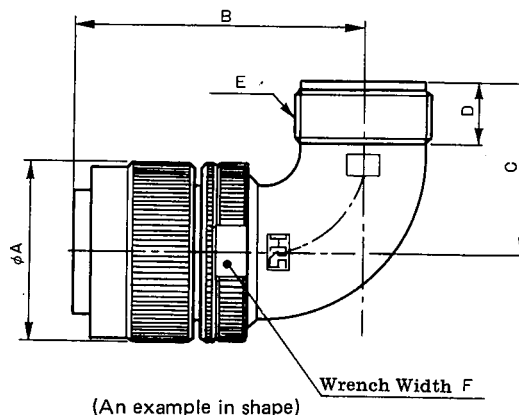
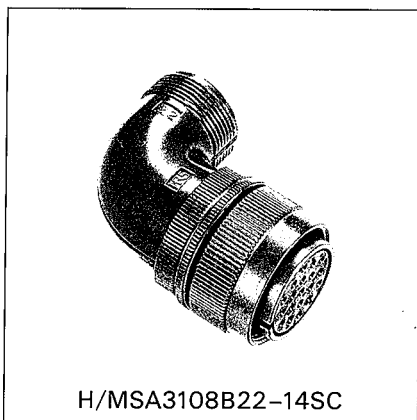

HRS No.	Part No.	No. of pins	ϕA	B	C	D	E	F	Remarks
120-1761-5	H/MSA3108B20-29SC	17	37	60.7	34	11.6	1 3/16-18UNEF-2A	35	

■ Right-Angle Plug (Waterproof Type)

(Crimp Type)

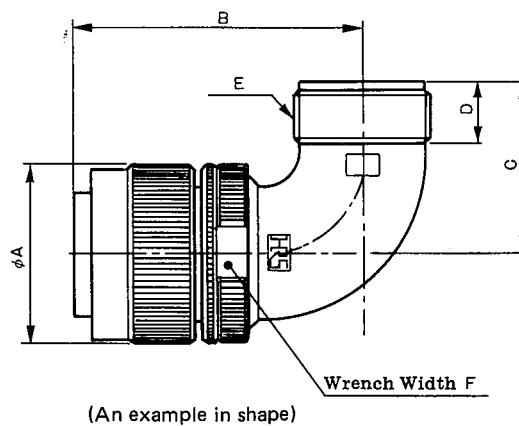
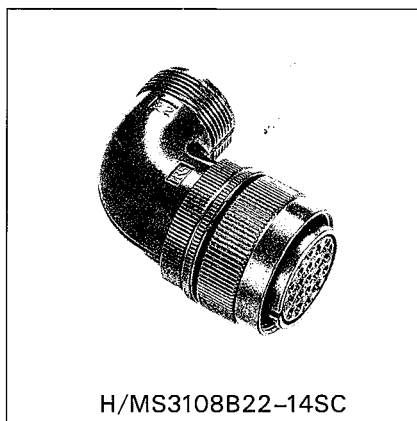

HRS No.	Part No.	No. of pins	ϕA	B	C	D	E	F	Remarks
120-1711-7	H/MSA3108B20-29SC	17	37	60.7	34	11.6	1 3/16-18UNEF-2A	35	
120-1713-2	H/MSA3108B22-14SC	19	39.5	60.7	34	11.6	1 3/16-18UNEF-2A	38	

■ Receptacle (Waterproof Type)

(Crimp Type)

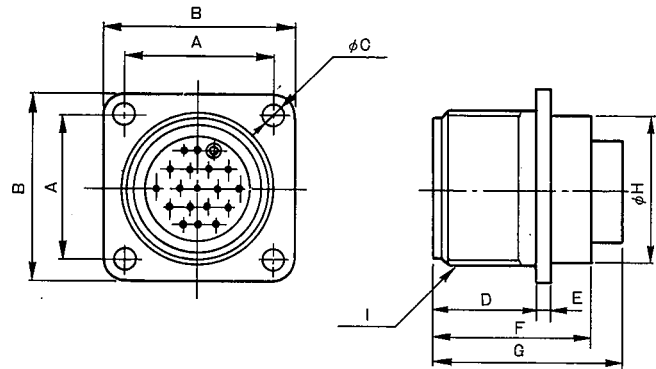
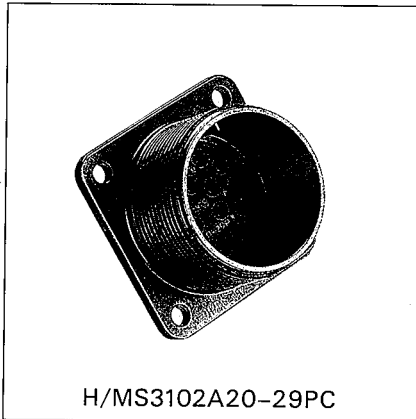

HRS No.	Part No.	No. of pins	A	B	φC	D	E	F	G	φH	I
120-0501-9	H/MS3102A20-29PC	17	29.36	38.1	3.3	19.3	2.8	29.4	37	29.6	1 1/4-18UNEF-2A
120-0502-1	H/MS3102A22-14PC	19	31.75	41.28	3.3	19.3	2.8	29.4	37	32.6	1 3/8-18UNEF-2A

■ Contact

(Male Pin)

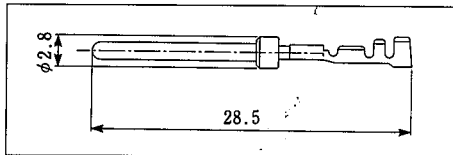

(Female Pin)

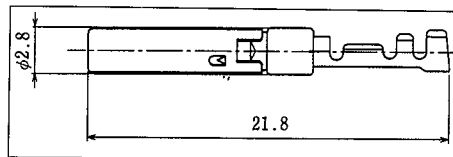

Type	HRS No.	Part No.	Applicable cable
Strip terminal	120-0533-5	H/MS-PC1-212	AWG#24~28
Loose piece terminal	120-0534-8	H/MS-PC1-112	AWG#24~28

Note: Strip terminals are available in a reel of 7,000 units, and loose piece terminals in a pack of 100 units.

Type	HRS No.	Part No.	Applicable cable
Strip terminal	120-1531-5	H/MS-SC-212	AWG#24~28

Note: Strip terminals are available in a reel of 7,000 units.

■ Dummy Pin

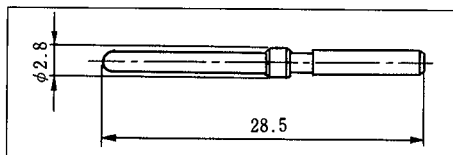

HRS No.	Part No.
120-0532-2	H/MS-PDC

Note: This is designed to be used for waterproof receptacles (crimp type). Do not fail to plug unused wiring holes using it.

◆ Installing receptacles

Use an O ring or similar material when installing a waterproof receptacle as shown in the Fig. on the right. Recommendable dimensions of O rings are shown in the Table below.

Part No.	φA	O-ring inside dia. (φ)	O-ring size (φ)
H/MS3102A10SL-□□	17.5	17.5	1.5
H/MS3102A18-□□	28.5	28.5	2
H/MS3102A20-□□	31.5	31.5	2
H/MS3102A22-□□	34.5	34.5	2
H/MS3102A24-□□	37.8	37.5	2

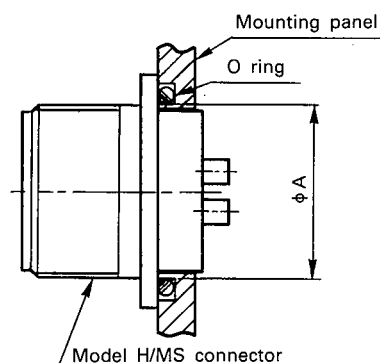

■ Cord Clamp

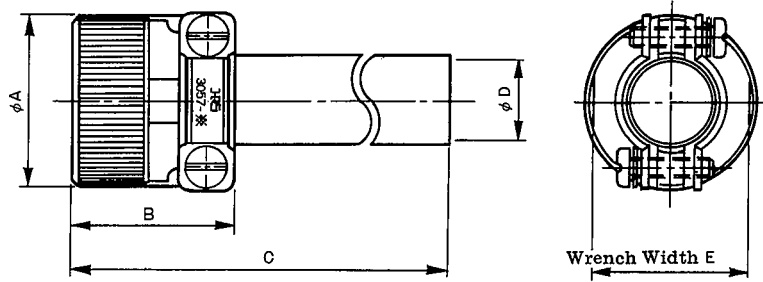
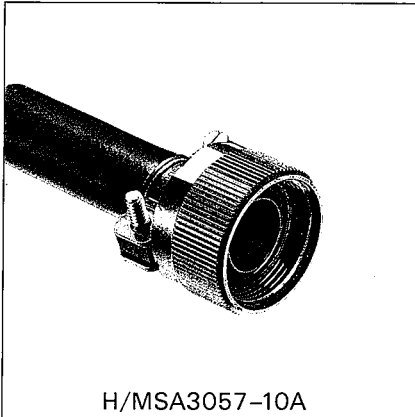

HRS No.	Part No.	φA	B	C	φD	E	Applicable cable dia. range (reference)	Applicable shell size	Remarks
120-0851-0	H/MSA3057-4A	20	26.8	85.3	5.6	17	φ 3.1 ~ φ 5.6	10SL	
120-0851-0-10	H/MSA3057-4A(10)	20	26.8	85.3	5.6	17	φ 3.1 ~ φ 5.6	10SL	Black
120-0852-3	H/MSA3057-10A	30	28.8	74.3	14.3	27	φ10.3 ~ φ14.3	18	
120-0852-3-10	H/MSA3057-10A(10)	30	28.8	74.3	14.3	27	φ10.3 ~ φ14.3	18	Black
120-0853-6	H/MSA3057-12A	34	29.8	72.8	15.9	30	φ11.4 ~ φ15.9	20, 22	
120-0853-6-10	H/MSA3057-12A(10)	34	29.8	72.8	15.9	30	φ11.4 ~ φ15.9	20, 22	Black
120-0855-1	H/MSA3057-12A1	34	29.8	72.8	11.6	30	φ 8 ~ φ11.6	20, 22	
120-0855-1-10	H/MSA3057-12A1(10)	34	29.8	72.8	11.6	30	φ 8 ~ φ11.6	20, 22	Black
120-0854-9	H/MSA3057-16A	40	33.8	71.3	19	36	φ14 ~ φ19	24	
120-0854-9-10	H/MSA3057-16A(10)	40	33.8	71.3	19	36	φ14 ~ φ19	24	Black
120-0856-4	H/MSA3057-16A1	40	33.8	71.3	14.2	36	φ10 ~ φ14.2	24	
120-0856-4-10	H/MSA3057-16A1(10)	40	33.8	71.3	14.2	36	φ10 ~ φ14.2	24	Black

[Waterproof type]

HRS No.	Part No.	φA	B	C	φD	E	Applicable cable dia. range (reference)	Applicable shell size	Remarks
120-0801-2	H/MS3057-4A	20	26.8	83.8	5.6	17	φ 3.1 ~ φ 5.6	10SL	
120-0801-2-10	H/MS3057-4A(10)	20	26.8	83.8	5.6	17	φ 3.1 ~ φ 5.6	10SL	Black
120-0802-5	H/MS3057-10A	30	28.8	72.8	14.3	27	φ10.3 ~ φ14.3	18	
120-0802-5-10	H/MS3057-10A(10)	30	28.8	72.8	14.3	27	φ10.3 ~ φ14.3	18	Black
120-0803-8	H/MS3057-12A	34	29.8	70.8	15.9	30	φ11.4 ~ φ15.9	20, 22	
120-0803-8-10	H/MS3057-12A(10)	34	29.8	70.8	15.9	30	φ11.4 ~ φ15.9	20, 22	Black
120-0805-3	H/MS3057-12A1	34	29.8	70.8	11.6	30	φ 8 ~ φ11.6	20, 22	
120-0805-3-10	H/MS3057-12A1(10)	34	29.8	70.8	11.6	30	φ 8 ~ φ11.6	20, 22	Black
120-0804-0	H/MS3057-16A	40	33.8	69.3	19	36	φ14 ~ φ19	24	
120-0804-0-10	H/MS3057-16A(10)	40	33.8	69.3	19	36	φ14 ~ φ19	24	Black
120-0806-6	H/MS3057-16A1	40	33.8	69.3	14.2	36	φ10 ~ φ14.2	24	
120-0806-6-10	H/MS3057-16A1(10)	40	33.8	69.3	14.2	36	φ10 ~ φ14.2	24	Black

Remarks: Check cable dia. carefully before using cables because clamping force and waterproofness vary depending on their types.

◆ Applicable tools

Type	Item	HRS No.	Part No.	Applicable terminal	Applicable wire
Manual	Manual crimping tool	150-0206-0	H/MS/CC-HT	H/MS-PC1-112	AWG # 24~ # 28
Automatic	Automatic crimping machine body	901-0005-4	CM-105	—	—
	Applicator	901-2027-8	AP105-H/MS-PC1-1	H/MS-PC-212	AWG # 24~ # 28
901-2032-8		AP105-H/MS-SC-212	H/MS-SC-212	AWG # 24~ # 28	
	Extractor	150-0076-7	H/MS-TP	H/MS-PC1-112 H/MS-PC1-212 H/MS-SC-212	—

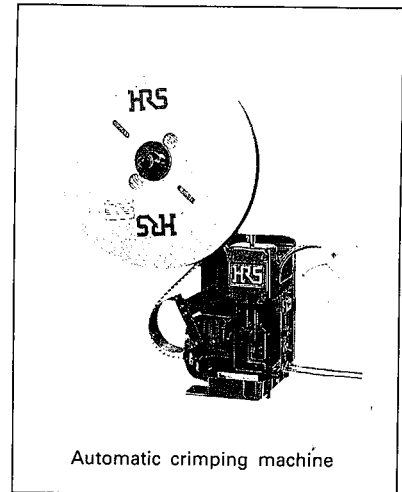
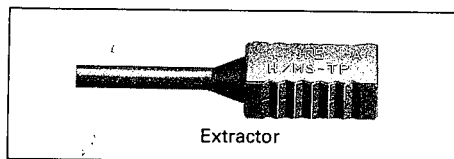
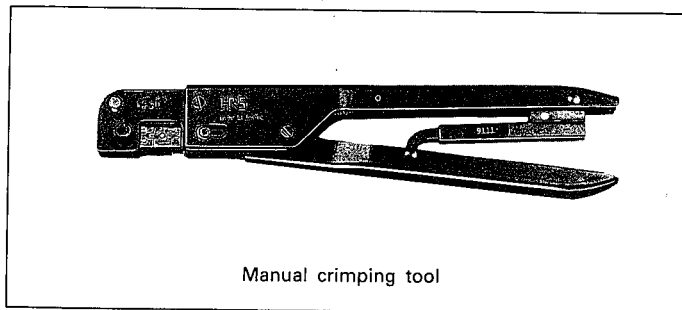

◆ Changes in insert position

Changes in insert position are shown as viewed from the mating side with the receptacle pin inserted. For details, see the Table and Figure below.

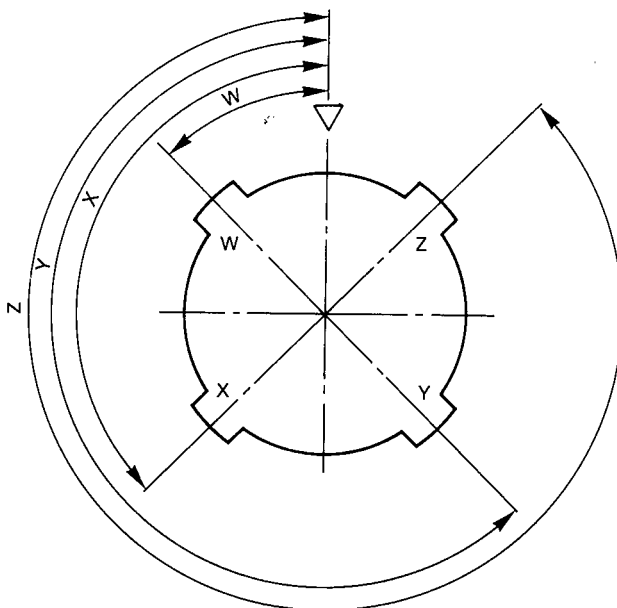

Product No.	Sign of position			
	W	X	Y	Z
H/MS※※18-10※	—	120°	240°	—
H/MS※※18-12※	80°	—	—	280°
H/MS※※20-15※	80°	—	—	280°
H/MS※※20-29※	80°	—	—	280°
H/MS※※22-14※	80°	—	—	280°
H/MS※※22-22※	—	110°	250°	—
H/MS※※22-23※	35°	—	250°	—
H/MS※※24-10※	80°	—	—	280°

Remarks: The numbers of products that require changes in insert position are given as follows:

Example: H/MS3102A18-10PX-D

— Add the sign of the insert position you desire to the product number.

◆ Connector combinations

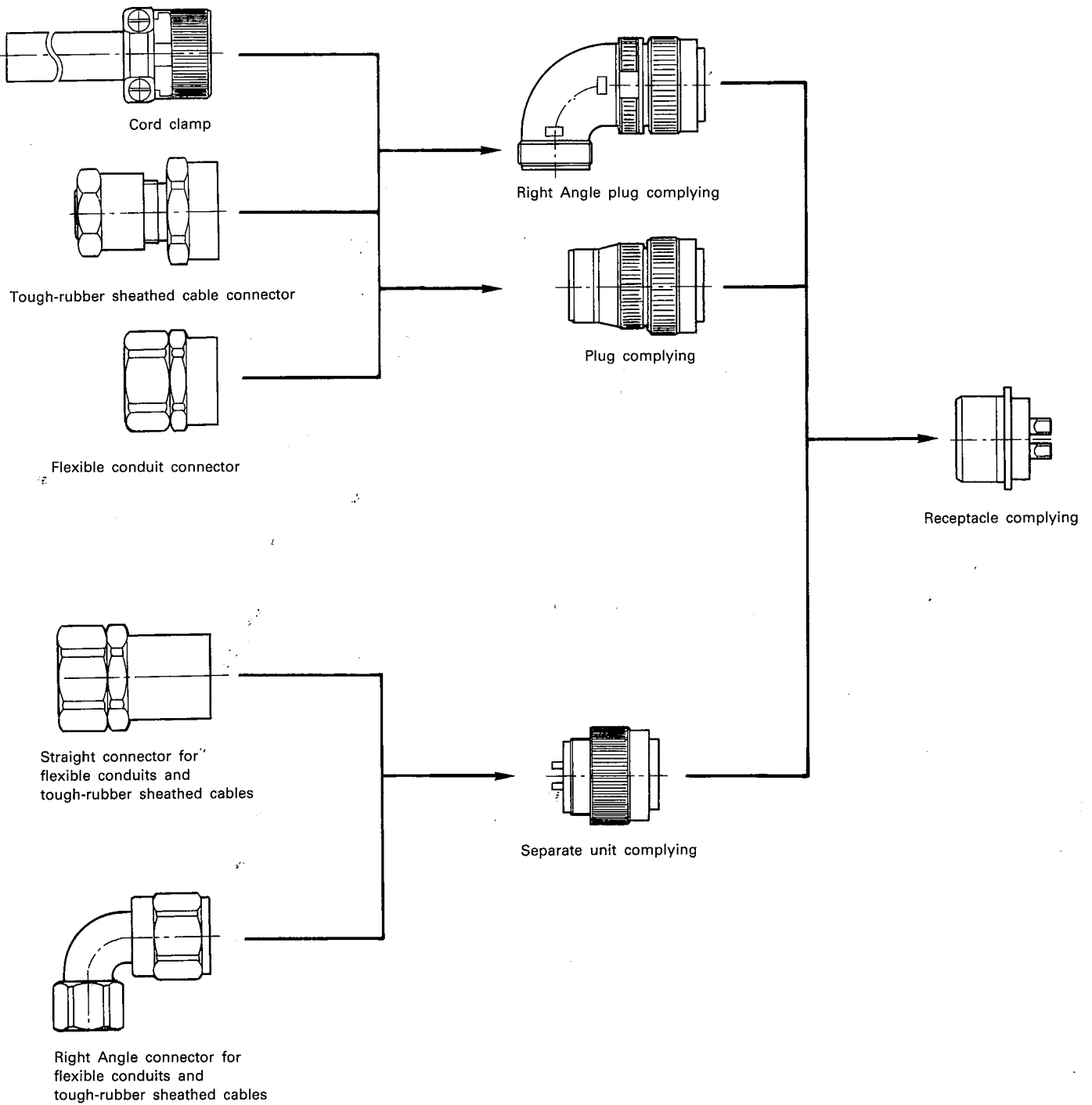

Remarks: The shapes of connectors for flexible conduit tubes and tough-rubber sheathed cables are just examples.

◆ Application List of H/MS Connectors and Connectors for Conduit Tubes and Tough-rubber sheathed cables

● Connectors for flexible conduit tubes

H/MS connector product No.	Nippon Flex (product No.)		Daiwa Dengyo (size)	
	Straight	Right Angle	Straight	Right Angle
H/MS3106A10SL-□□	RCC-10※CA12 (with O ring)	—	NBDC 12S-※※ (with O ring)	—
H/MS3108B10SL-□□	RCC-10※CA12		NBDC 12S-※※	
H/MS3106A10SL-□□(03)	RCC-10※RL-MS10F	RCC-30※RL-MS10F	BOS 10-※	BOL 10-※
H/MS3106A18-□□	RCC-10※CA18 (with O ring)	—	NBDC 18-※※ (with O ring)	—
H/MS3108B18-□□	RCC-10※CA18		NBDC 18-※※	
H/MS3106A18-□□(03)	RCC-10※RL-MS18F	RCC-30※RL-MS18F	BOS 18-※※	BOL 18-※※
H/MS3106A20-□□	RCC-10※CA2022 (with O ring)	—	NBDC 20(22)-※※ (with O ring)	—
H/MS3108B20-□□	RCC-10※CA2022		NBDC 20(22)-※※	
H/MS3106A20-□□(03)	RCC-10※RL-MS20F	RCC-30※RL-MS20F	BOS 20-※※	BOL 20-※※
H/MS3106A22-□□	RCC-10※CA2022 (with O ring)	—	NBDC 20(22)-※※ (with O ring)	—
H/MS3108B22-□□	RCC-10※CA2022		NBDC 20(22)-※※	
H/MS3106A22-□□(03)	RCC-10※RL-MS22F	RCC-30※RL-MS22F	BOS 22-※※	BOL 22-※※
H/MS3106A24-□□	RCC-10※CA2428 (with O ring)	—	NBDC 24-※※ (with O ring)	—
H/MS3108B24-□□	RCC-10※CA2428		NBDC 24-※※	
H/MS3106A24-□□(03)	RCC-10※RL-MS24F	RCC-30※RL-MS24F	BOS 24-※※	BOL-24-※※

● Connectors for Tough-rubber sheathed cables

H/MS connector product No.	Nippon Flex (product No.)		Daiwa Dengyo (size)	
	Straight	Right Angle	Straight	Right Angle
H/MS3106A10SL-□□	—	—	YDC 12S-※ (with O ring)	—
H/MS3108B10SL-□□			YDC 12S-※	
H/MS3106A10SL-□□(03)	ACS-※※RL-MS10F	ACA-※※RL-MS10F	YSO 10-※	YLO 10-※
H/MS3106A18-□□	ACS-※※CA18	—	YDC 18-※※ (with O ring)	—
H/MS3108B18-□□			YDC 18-※※	
H/MS3106A18-□□(03)	ACS-※※RL-MS18F	ACA-※※RL-MS18F	YSO 18-※※	YLO 18-※※
H/MS3106A20-□□	ACS-※※CA2022	—	YDC 20(22)-※※ (with O ring)	—
H/MS3108B20-□□			YDC 20(22)-※※	
H/MS3106A20-□□(03)	ACS-※※RL-MS20F	ACA-※※RL-MS20F	YSO 20-※※	YLO 20-※※
H/MS3106A22-□□	ACS-※※CA2022	—	YDC 20(22)-※※ (with O ring)	—
H/MS3108B22-□□			YDC 20(22)-※※	
H/MS3106A22-□□(03)	ACS-※※RL-MS22F	ACA-※※RL-MS22F	YSO 22-※※	YLO 20-※※
H/MS3106A24-□□	ACS-※※CA2428	—	YDC 24-※※ (with O ring)	—
H/MS3108B24-□□			YDC 24-※※	
H/MS3106A24-□□(03)	ACS-※※RL-MS24F	ACA-※※RL-MS24F	YSO 24-※※	YLO 24-※※

Remarks

- : Terminal arrangement sign
- ※※ : Different depending on cables used

◆ Terminal arrangement and main performance

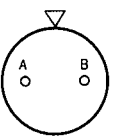
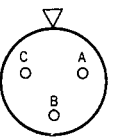
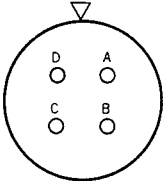
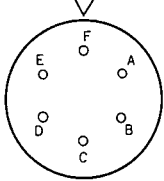
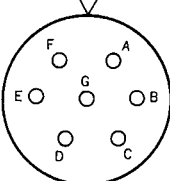
Shell size	10SL		18		20
	4	3	10	12	15
Terminal arrangement					
No. of contacts	2	3	4	6	7
Withstanding voltage	1000 VAC for 1 min.	1000 VAC for 1 min.	2000 VAC for 1 min.	2000 VAC for 1 min.	2000 VAC for 1 min.
Rated current	13A (24.5A)	13A (34.5A)	23A (76.2A)	13A (55.6A)	23A (105.7A)
Insulation resistance	DC500V 5000MΩ MIN.	DC500V 5000MΩ MIN.	DC500V 5000MΩ MIN.	DC500V 5000MΩ MIN.	DC500V 5000MΩ MIN.
Contact resistance	5mΩ MAX	5mΩ MAX	3mΩ MAX	5mΩ MAX	3mΩ MAX
Solder pot inside dia.	φ 1.8	φ 1.8	φ 2.9	φ 1.8	φ 2.9
Spare solder	Not provided	Not provided	Provided	Not provided	Provided

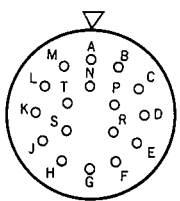
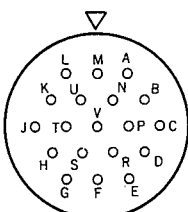
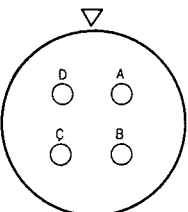
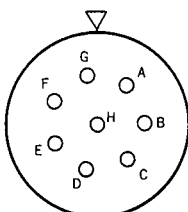
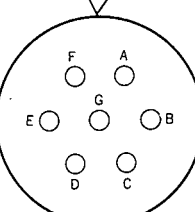
Shell size	20	22	22	23	24
	29	14	22	23	10
Terminal arrangement					
No. of contacts	17	19	4	8	7
Withstanding voltage	2000 VAC for 1 min.	2000 VAC for 1 min.	2000 VAC for 1 min.	2000 VAC for 1 min.	2000 VAC for 1 min.
Rated current	13A (44.2A)	13A (49.4A)	46A (152.5A)	23A (100.4A)	46A (211.5A)
Insulation resistance	DC500V 5000MΩ MIN.	DC500V 5000MΩ MIN.	DC500V 5000MΩ MIN.	DC500V 5000MΩ MIN.	DC500V 5000MΩ MIN.
Contact resistance	5mΩ MAX	5mΩ MAX	1mΩ MAX	3mΩ MAX	1mΩ MAX
Solder pot inside dia.	φ 1.8	φ 1.8	φ 5.3	φ 2.9	φ 5.3
Spare solder	Not provided	Not provided	Provided	Provided	Provided

Remarks:

- The above figures show the receptacle pin inserts as viewed from the mating side (socket insert termination side of the plugs).
- Withstand voltage shows the testing voltage.
- Rate current shows the capacity per terminal.
Figure in () shows the total current capacity of a connector.
- Contact resistance is as measured at 1 ADC.
- For details, please contact us.

◆ (CONTACT) Approved by German specification DIN, VDE 0627

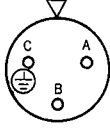
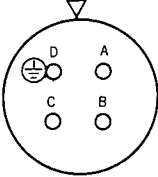
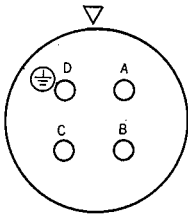
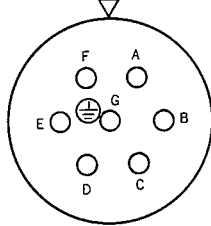
Shell size	10SL			18		22			24	
	3			10		22			10	
Contact arrangement										
No. of pins	3			4		4			7	
Grounding terminal No.	C			D		D			G	
AC, DC rated voltage (V)	200			500		500			250	
Current rating (A)	7	10	13	17	23	23	35	46	23	35
Wire size (mm ²)	0.5	0.75	1.25	2	3.5	3.5	5.5	8	3.5	5.5
Pollution degree	3			2		2			2	
Over current range	III			II		II			II	

Remarks:

1. The figure shows the contact arrangements viewed from the fitting side of socket insert (connecting side of pin inserts).
2. Current rating is the capacity per terminal.
3. In case of size 24-10 receptacles are non-conducted between grounding terminal and shell of connectors, other size and size 24-10 plug are conducted between earth and shell of connectors.
4. The pollution degree and over current range is mean DIN VDE 0110 (coordination of insulation for low voltage equipment of an electrical appliance) classified for using of an electrical appliances of environment condition and classified for over voltage of an electrical appliances.
5. Performances excluding above tables are in accordance with general H/MS.

Copyright © Each Manufacturing Company.

All Datasheets cannot be modified without permission.

This datasheet has been download from :

www.AllDataSheet.com

100% Free DataSheet Search Site.

Free Download.

No Register.

Fast Search System.

www.AllDataSheet.com