

# International IR Rectifier

## IR2122(S)

### CURRENT SENSING SINGLE CHANNEL DRIVER

#### Features

- Floating channel designed for bootstrap operation  
Fully operational to +600V  
Tolerant to negative transient voltage  
dV/dt immune
- Gate drive supply range from 10 to 20V
- Undervoltage lockout
- 3.3V, 5V and 15V input logic compatible
- FAULT lead indicates shutdown has occurred
- Output out of phase with input

#### Description

The IR2122(S) is a high voltage, high speed power MOSFET and IGBT driver. Proprietary HVIC and latch immune CMOS technologies enable ruggedized monolithic construction. The logic input is compatible with standard CMOS or LSTTL outputs, down to 3.3V. The protection circuitry detects over-current in the driven power transistor and terminates the gate drive voltage. An open drain FAULT signal is provided to indicate that an over-current shutdown has occurred. The output driver features a high pulse current buffer stage designed for minimum cross-conduction. The floating channel can be used to drive an N-channel power MOSFET or IGBT in the high side or low side configuration which operates up to 600 volts.

#### Product Summary

$V_{\text{OFFSET}}$	600V max.
$I_{\text{O+/-}}$	110 mA / 110 mA
$V_{\text{OUT}}$	10 - 20V
$V_{\text{Csth}}$	500 mV
$t_{\text{on/off (typ.)}}$	250 & 200 ns

#### Packages

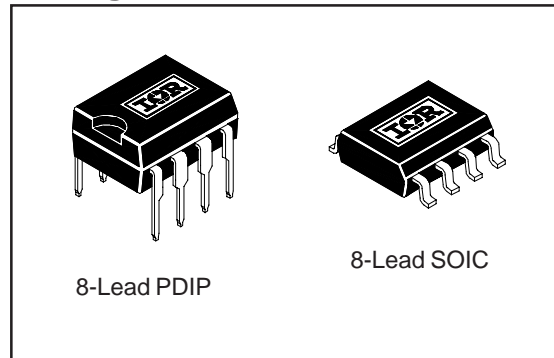

#### Typical Connection

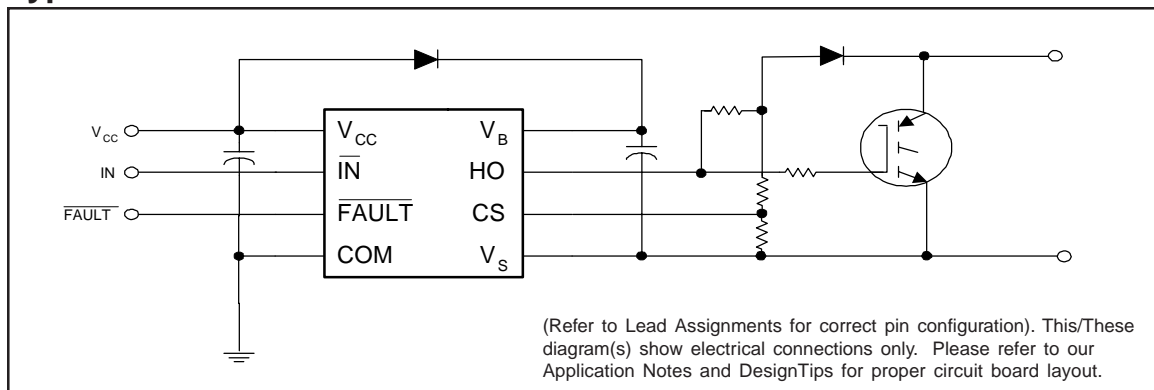

## Absolute Maximum Ratings

Absolute Maximum Ratings indicate sustained limits beyond which damage to the device may occur. All voltage parameters are absolute voltages referenced to COM. The Thermal Resistance and Power Dissipation ratings are measured under board mounted and still air conditions.

Symbol	Definition	Min.	Max.	Units	
V <sub>B</sub>	High Side Floating Supply Voltage	-0.3	625	V	
V <sub>S</sub>	High Side Floating Offset Voltage	V <sub>B</sub> - 25	V <sub>B</sub> + 0.3		
V <sub>HO</sub>	High Side Floating Output Voltage	V <sub>S</sub> - 0.3	V <sub>B</sub> + 0.3		
V <sub>CC</sub>	Logic Supply Voltage	-0.3	25		
V <sub>IN</sub>	Logic Input Voltage	-0.3	V <sub>CC</sub> + 0.3		
V <sub>FLT</sub>	FAULT Output Voltage	-0.3	V <sub>CC</sub> + 0.3		
V <sub>CS</sub>	Current Sense Voltage	V <sub>S</sub> - 0.3	V <sub>B</sub> + 0.3		
dV <sub>S</sub> /dt	Allowable Offset Supply Voltage Transient	—	50	V/ns	
P <sub>D</sub>	Package Power Dissipation @ T <sub>A</sub> ≤ +25°C	(8 Lead DIP)	—	1.0	W
		(8 Lead SOIC)	—	0.625	
R <sub>THJA</sub>	Thermal Resistance, Junction to Ambient	(8 Lead DIP)	—	125	°C/W
		(8 Lead SOIC)	—	200	
T <sub>J</sub>	Junction Temperature	—	150	°C	
T <sub>S</sub>	Storage Temperature	-55	150		
T <sub>L</sub>	Lead Temperature (Soldering, 10 seconds)	—	300		

## Recommended Operating Conditions

The Input/Output logic timing diagram is shown in Figure 1. For proper operation the device should be used within the recommended conditions. The V<sub>S</sub> offset rating is tested with all supplies biased at 15V differential.

Symbol	Definition	Min.	Max.	Units
V <sub>B</sub>	High Side Floating Supply Voltage	V <sub>S</sub> + 13	V <sub>S</sub> + 20	V
V <sub>S</sub>	High Side Floating Offset Voltage	Note 1	600	
V <sub>HO</sub>	High Side Floating Output Voltage	V <sub>S</sub>	V <sub>B</sub>	
V <sub>CC</sub>	Logic Supply Voltage	13	20	
V <sub>IN</sub>	Logic Input Voltage	0	V <sub>CC</sub>	
V <sub>FLT</sub>	FAULT Output Voltage	0	V <sub>CC</sub>	
V <sub>CS</sub>	Current Sense Signal Voltage	V <sub>S</sub>	V <sub>S</sub> + 5	°C
T <sub>A</sub>	Ambient Temperature	-40	150	

Note 1: Logic operational for V<sub>S</sub> of -5 to +600V. Logic state held for V<sub>S</sub> of -5V to -V<sub>BS</sub>. (Please refer to the Design Tip DT97-3 for more details).

### Dynamic Electrical Characteristics

$V_{BIAS}$  ( $V_{CC}$ ,  $V_{BS}$ ) = 15V,  $C_L$  = 1000 pF and  $T_A$  = 25°C unless otherwise specified. The dynamic electrical characteristics are measured using the test circuit shown in Figure 3.

Symbol	Definition	Min.	Typ.	Max.	Units	Test Conditions
$t_{on}$	Turn-On Propagation Delay	—	250	—	ns	$V_S = 0V$
$t_{off}$	Turn-Off Propagation Delay	—	200	—		$V_S = 600V$
$t_r$	Turn-On Rise Time	—	250	—		$C_L = 1000$ pF
$t_f$	Turn-Off Fall Time	—	250	—		$C_L = 1000$ pF
$t_{bl}$	Start-Up Blanking Time	500	900	—		
$t_{cs}$	CS Shutdown Propagation Delay	—	350	—		
$t_{fit}$	CS to $\overline{FAULT}$ Pull-Up Propagation Delay	—	450	—		

### Static Electrical Characteristics

$V_{BIAS}$  ( $V_{CC}$ ,  $V_{BS}$ ) = 15V and  $T_A$  = 25°C unless otherwise specified. The  $V_{IN}$ ,  $V_{TH}$  and  $I_{IN}$  parameters are referenced to COM. The  $V_O$  and  $I_O$  parameters are referenced to  $V_S$ .

Symbol	Definition	Min.	Typ.	Max.	Units	Test Conditions
$V_{IH}$	Logic "0" Input Voltage (OUT = LO)	3.0	—	—	V	$V_{CC} = 10V$ to 20V
$V_{IL}$	Logic "1" Input Voltage (OUT = HI)	—	—	0.8		$V_{CC} = 10V$ to 20V
$V_{CSTH+}$	CS Input Positive Going Threshold	350	500	650		$V_{CC} = 10V$ to 20V
$V_{OH}$	High Level Output Voltage, $V_{BIAS} - V_O$	—	—	100	mV	$I_O = 0A$
$V_{OL}$	Low Level Output Voltage, $V_O$	—	—	100		$I_O = 0A$
$I_{LK}$	Offset Supply Leakage Current	—	—	50		$V_B = V_S = 600V$
$I_{QBS}$	Quiescent $V_{BS}$ Supply Current	—	150	350	$\mu A$	$V_{IN} = 0V$ or 5V
$I_{QCC}$	Quiescent $V_{CC}$ Supply Current	—	60	120		$V_{IN} = 0V$ or 5V
$I_{IN+}$	Logic "1" Input Bias Current	—	7.0	15		$V_{IN} = 0V$
$I_{IN-}$	Logic "0" Input Bias Current	—	—	1.0		$V_{IN} = 5V$
$I_{CS+}$	"High" CS Bias Current	—	—	1.0		$V_{CS} = 3V$
$I_{CS-}$	"High" CS Bias Current	—	—	1.0		$V_{CS} = 0V$
$V_{BSUV+}$	$V_{BS}$ Supply Undervoltage Positive Going Threshold	10.0	11.4	13.0	V	
$V_{BSUV-}$	$V_{BS}$ Supply Undervoltage Negative Going Threshold	9.5	10.4	12.5		
$I_{O+}$	Output High Short Circuit Pulsed Current	110	130	—	mA	$V_O = 0V$ , $V_{IN} = 0V$ $PW \leq 10 \mu s$
$I_{O-}$	Output Low Short Circuit Pulsed Current	110	130	—		$V_O = 15V$ , $V_{IN} = 5V$ $PW \leq 10 \mu s$

# IR2122(S)



## Functional Block Diagram

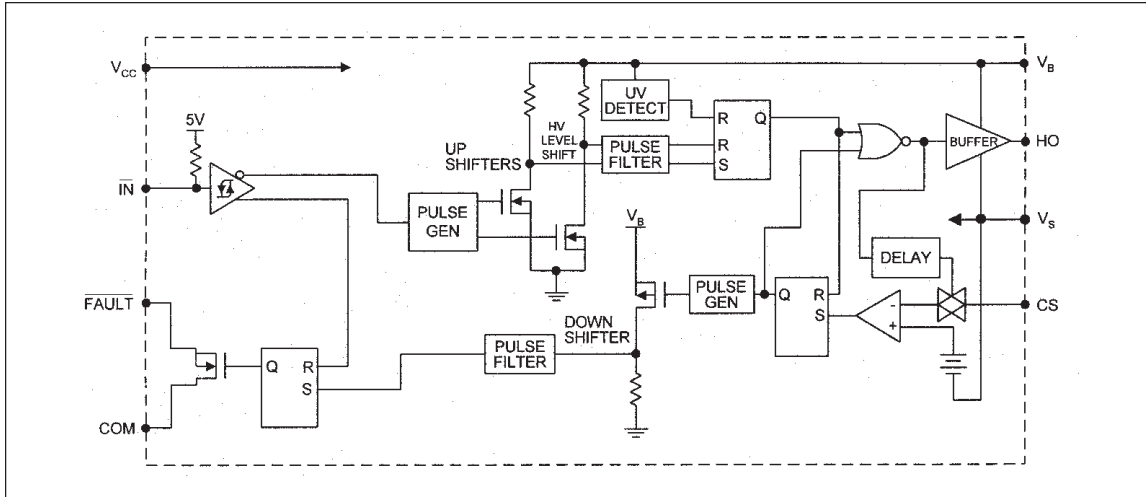

## Lead Definitions

Symbol	Description
$V_{CC}$	Logic and gate drive supply
$\overline{IN}$	Logic input for gate driver output (HO), out of phase with HO
$\overline{FAULT}$	Indicates over-current shutdown has occurred, negative logic
COM	Logic ground
$V_B$	High side floating supply
HO	High side gate drive output
$V_S$	High side floating supply return
CS	Current sense input to current sense comparator

## Lead Assignments

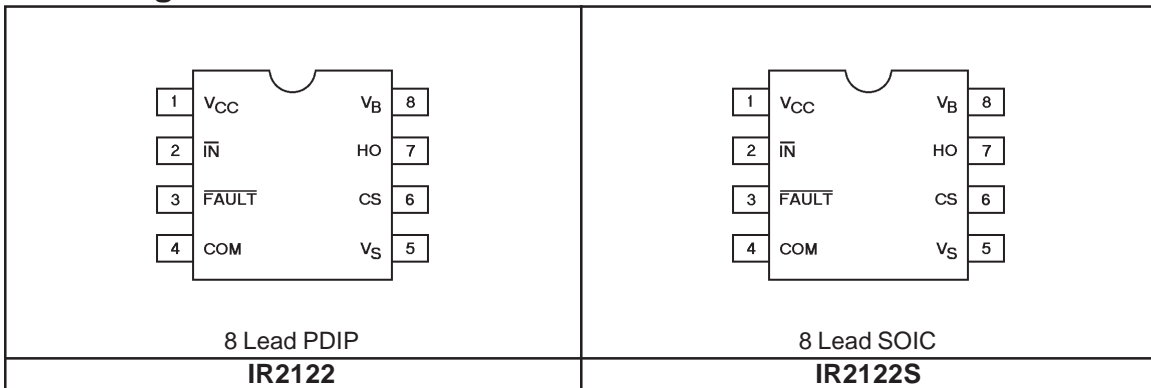

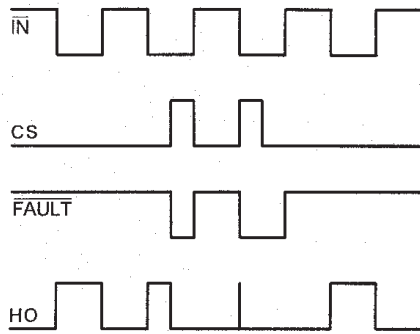

Figure 1. Input/Output Timing Diagram

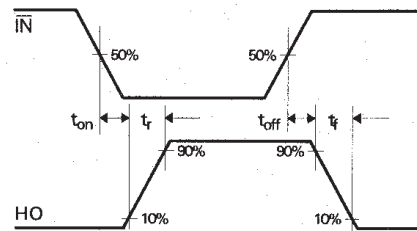

Figure 2. Switching Time Waveform Definition

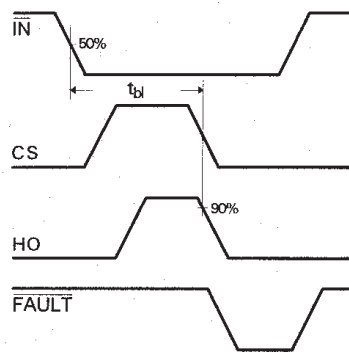

Figure 3. Start-up Blanking Time Waveform Definitions

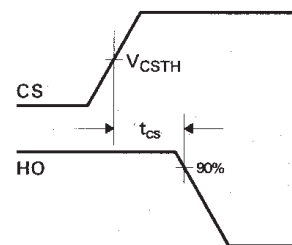

Figure 4. CS Shutdown Waveform Definitions

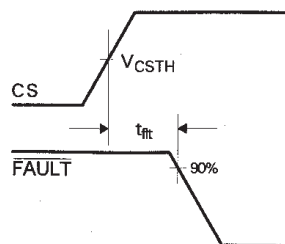
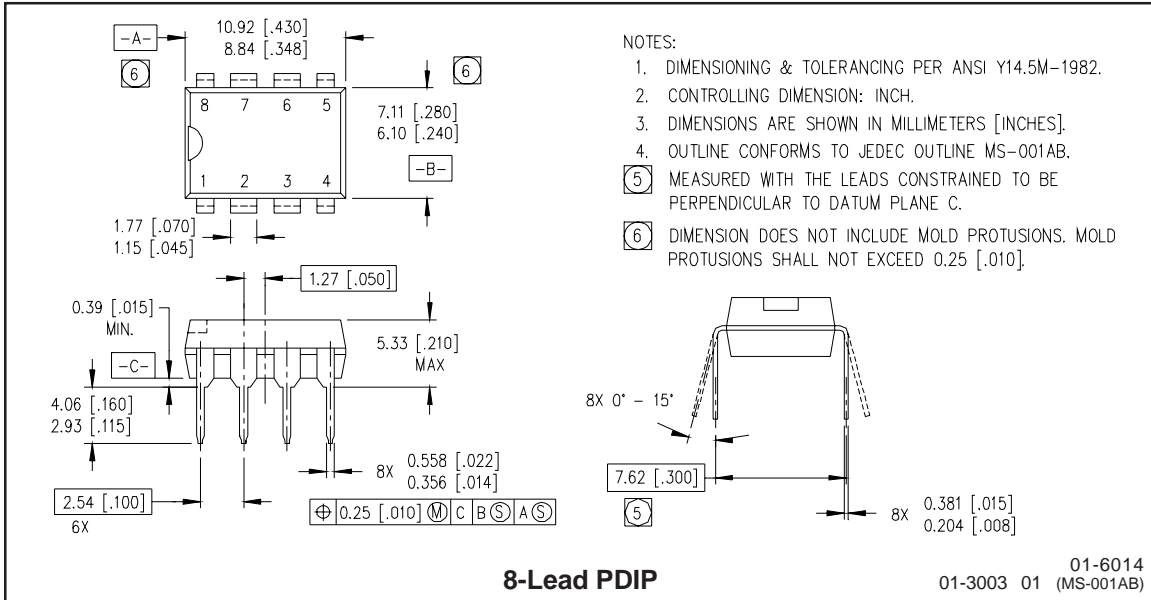

Figure 5. CS to  $\overline{\text{FAULT}}$  Waveform Definitions

# IR2122(S)

## Case outlines



**8-Lead PDIP**

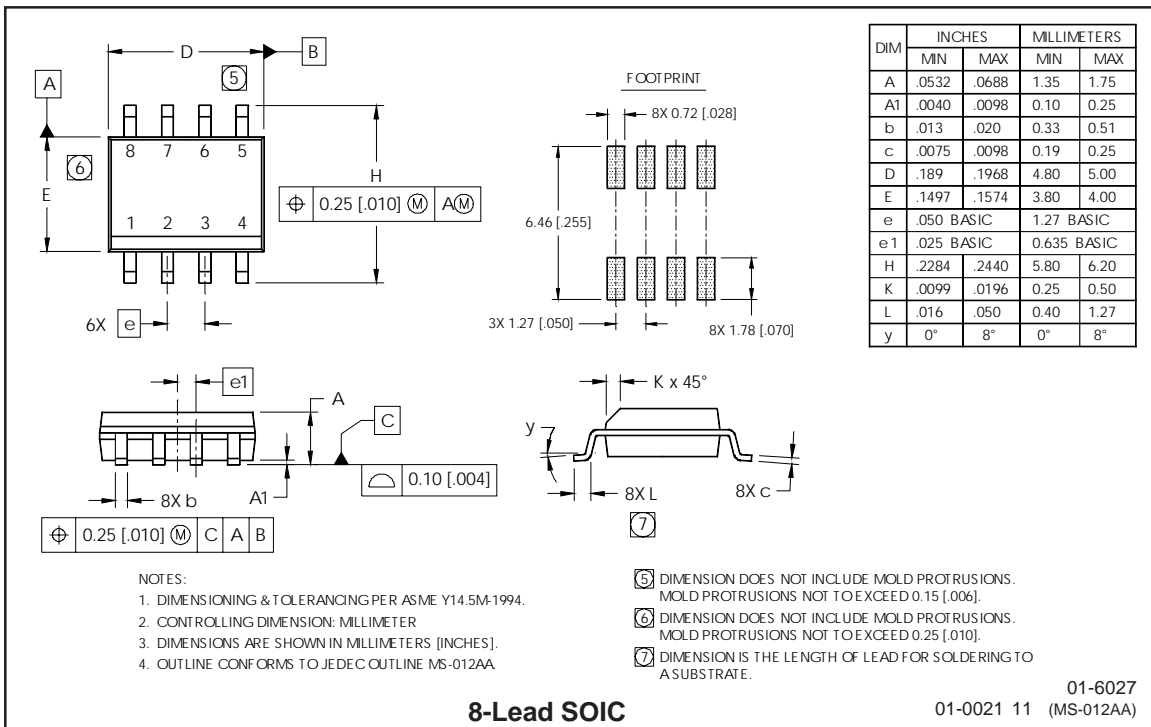

**8-Lead SOIC**

IR WORLD HEADQUARTERS: 233 Kansas St., El Segundo, California 90245 Tel: (310) 252-7105  
Data and specifications subject to change without notice. 5/15/2001