

DATA SHEET

74F112

Dual J-K negative edge-triggered flip-flop

Product specification

1990 Feb 09

IC15 Data Handbook

Dual J-K negative edge-triggered flip-flop

74F112

FEATURE

- Industrial temperature range available (−40°C to +85°C)

DESCRIPTION

The 74F112, Dual Negative Edge-Triggered JK-Type Flip-Flop, feature individual J, K, Clock (\overline{CP}_n), Set (\overline{SD}) and Reset (\overline{RD}) inputs, true (Q_n) and complementary (\overline{Q}_n) outputs.

The \overline{SD} and \overline{RD} inputs, when Low, set or reset the outputs as shown in the Function Table, regardless of the level at the other inputs.

A High level on the clock (\overline{CP}_n) input enables the J and K inputs and data will be accepted. The logic levels at the J and K inputs may be allowed to change while the \overline{CP}_n is High and flip-flop will perform according to the Function Table as long as minimum setup and hold times are observed. Output changes are initiated by the High-to-Low transition of the \overline{CP}_n .

PIN CONFIGURATION

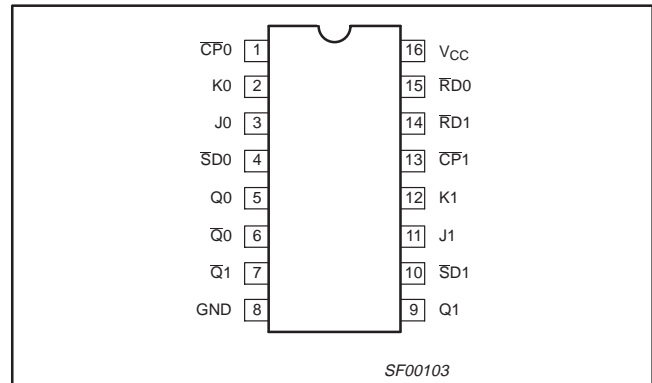

TYPE	TYPICAL PROPAGATION DELAY	TYPICAL SUPPLY CURRENT (TOTAL)
74F112	100MHz	15mA

ORDERING INFORMATION

DESCRIPTION	ORDER CODE		PKG DWG #
	COMMERCIAL RANGE $V_{CC} = 5V \pm 10\%$, $T_{amb} = 0^\circ C$ to $+70^\circ C$	INDUSTRIAL RANGE $V_{CC} = 5V \pm 10\%$, $T_{amb} = -40^\circ C$ to $+85^\circ C$	
16-pin plastic DIP	N74F112N	I74F112N	SOT38-4
16-pin plastic SO	N74F112D	I74F112D	SOT109-1

INPUT AND OUTPUT LOADING AND FAN-OUT TABLE

PINS	DESCRIPTION	74F (U.L.) HIGH/LOW	LOAD VALUE HIGH/LOW
J0, J1	J inputs	1.0/1.0	20µA/0.6mA
K0, K1	K inputs	1.0/1.0	20µA/0.6mA
$\overline{SD}_0, \overline{SD}_1$	Set inputs (active Low)	1.0/5.0	20µA/3.0mA
$\overline{RD}_0, \overline{RD}_1$	Reset inputs (active Low)	1.0/5.0	20µA/3.0mA
$\overline{CP}_0, \overline{CP}_1$	Clock Pulse input (active falling edge)	1.0/4.0	20µA/2.4mA
Q0, \overline{Q}_0 ; Q1, \overline{Q}_1	Data outputs	50/33	1.0mA/20mA

NOTE:

One (1.0) FAST unit load is defined as: 20µA in the High state and 0.6mA in the Low state.

Dual J-K negative edge-triggered flip-flop

74F112

LOGIC SYMBOL

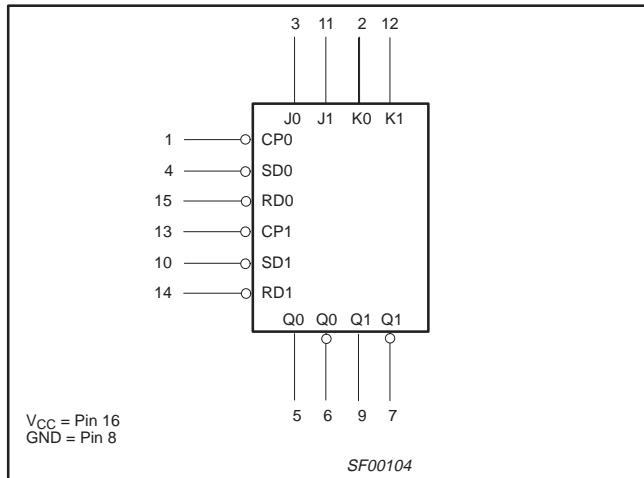

IEC/IEEE SYMBOL

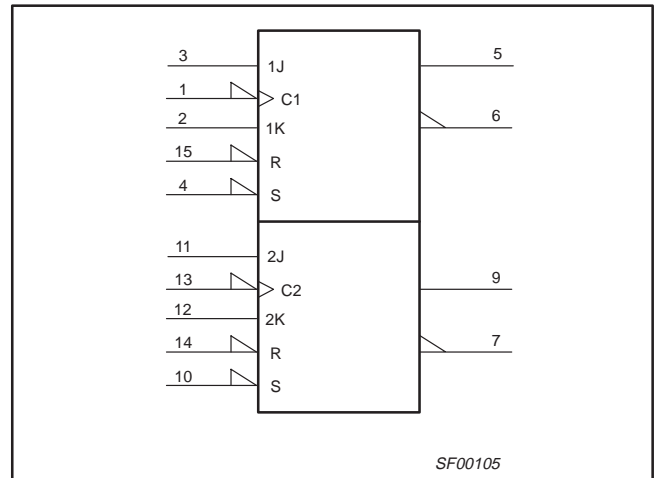

LOGIC DIAGRAM

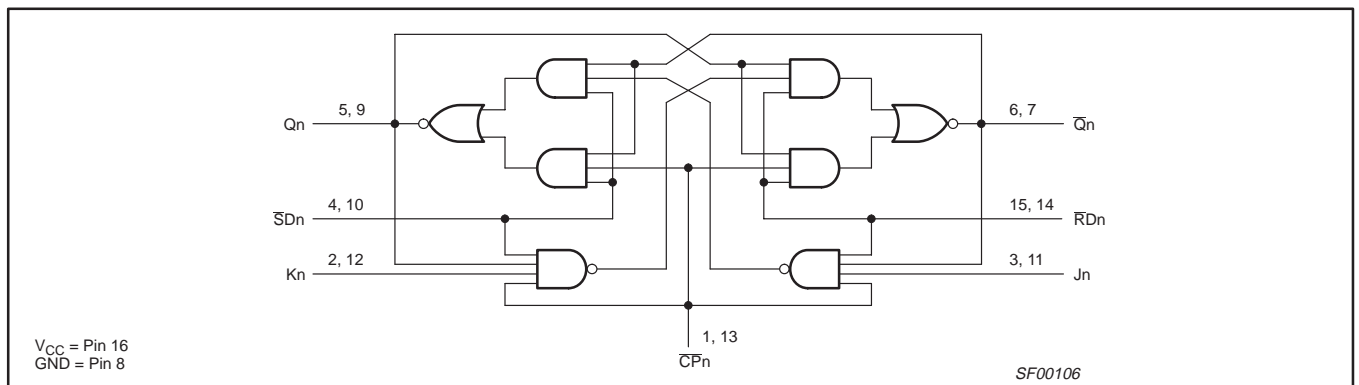

FUNCTION TABLE

INPUTS					OUTPUTS		OPERATING MODE
SD	RD	CP	J	K	Q	Q̄	
L	H	X	X	X	H	L	Asynchronous Set
H	L	X	X	X	L	H	Asynchronous Reset
L	L	X	X	X	H*	H*	Undetermined *
H	H	↓	h	h	q̄	q	Toggle
H	H	↓	l	h	L	H	Load "0" (Reset)
H	H	↓	h	l	H	L	Load "1" (Set)
H	H	↓	l	l	q	q̄	Hold "no change"
H	H	H	X	X	Q	Q̄	Hold "no change"

H = High voltage level

h = High voltage level one setup time prior to High-to-Low clock transition

L = Low voltage level

l = Low voltage level one setup time prior to High-to-Low clock transition

q = Lower case letters indicate the state of the reference output prior to the High-to-Low clock transition

X = Don't care

↓ = High-to-Low clock transition

* = Both outputs will be High while both SD and RD are Low, but the output states are unpredictable if SD and RD go High simultaneously.

Dual J-K negative edge-triggered flip-flop

74F112

ABSOLUTE MAXIMUM RATINGS

(Operation beyond the limits set forth in this table may impair the useful life of the device.
Unless otherwise noted these limits are over the operating free-air temperature range.)

SYMBOL	PARAMETER		RATING	UNIT	
V_{CC}	Supply voltage		-0.5 to +7.0	V	
V_{IN}	Input voltage		-0.5 to +7.0	V	
I_{IN}	Input current		-30 to +5	mA	
V_{OUT}	Voltage applied to output in High output state		-0.5 to V_{CC}	V	
I_{OUT}	Current applied to output in Low output state		40	mA	
T_{amb}	Operating free-air temperature range		Commercial range	0 to +70	°C
			Industrial range	-40 to +85	°C
T_{stg}	Storage temperature range		-65 to +150	°C	

RECOMMENDED OPERATING CONDITIONS

SYMBOL	PARAMETER	LIMITS			UNIT	
		MIN	NOM	MAX		
V_{CC}	Supply voltage	4.5	5.0	5.5	V	
V_{IH}	High-level input voltage	2.0			V	
V_{IL}	Low-level input voltage			0.8	V	
I_{IK}	Input clamp current			-18	mA	
I_{OH}	High-level output current			-1	mA	
I_{OL}	Low-level output current			20	mA	
T_{amb}	Operating free-air temperature range		Commercial range	0	+70	°C
			Industrial range	-40	+85	°C

DC ELECTRICAL CHARACTERISTICS

(Over recommended operating free-air temperature range unless otherwise noted.)

SYMBOL	PARAMETER	TEST CONDITIONS ¹	LIMITS			UNIT	
			MIN	TYP ²	MAX		
V_{OH}	High-level output voltage	$V_{CC} = \text{MIN}, V_{IL} = \text{MAX}$	$\pm 10\%V_{CC}$	2.5		V	
		$V_{IH} = \text{MIN}, I_{OH} = \text{MAX}$	$\pm 5\%V_{CC}$	2.7	3.4		
V_{OL}	Low-level output voltage	$V_{CC} = \text{MIN}, V_{IL} = \text{MAX}$	$\pm 10\%V_{CC}$		0.35	V	
		$V_{IH} = \text{MIN}, I_{OL} = \text{MAX}$	$\pm 5\%V_{CC}$		0.35		
V_{IK}	Input clamp voltage	$V_{CC} = \text{MIN}, I_I = I_{IK}$		-0.73	-1.2	V	
I_I	Input current at maximum input voltage	$V_{CC} = \text{MAX}, V_I = 7.0V$			100	μA	
I_{IH}	High-level input current	$V_{CC} = \text{MAX}, V_I = 2.7V$			20	μA	
I_{IL}	Low-level input current	Jn, Kn			-0.6	mA	
		$\overline{\text{CPn}}$	$V_{CC} = \text{MAX}, V_I = 0.5V$			-2.4	mA
		$\overline{\text{SDn}}, \text{RDn}$				-3.0	mA
I_{OS}	Short-circuit output current ³	$V_{CC} = \text{MAX}$		-60	-150	mA	
I_{CC}	Supply current (total) ⁴	$V_{CC} = \text{MAX}$		15	21	mA	

NOTES:

- For conditions shown as MIN or MAX, use the appropriate value specified under recommended operating conditions for the applicable type.
- All typical values are at $V_{CC} = 5V, T_{amb} = 25^\circ\text{C}$.
- Not more than one output should be shorted at a time. For testing I_{OS} , the use of high-speed test apparatus and/or sample-and-hold techniques are preferable in order to minimize internal heating and more accurately reflect operational values. Otherwise, prolonged shorting of a High output may raise the chip temperature well above normal and thereby cause invalid readings in other parameter tests. In any sequence of parameter tests, I_{OS} tests should be performed last.
- Measure I_{CC} with the clock input grounded and all outputs open, with the Q and \overline{Q} outputs High in turn.

Dual J-K negative edge-triggered flip-flop

74F112

AC ELECTRICAL CHARACTERISTICS

SYMBOL	PARAMETER	TEST CONDITION	LIMITS						UNIT	
			$V_{CC} = +5.0V$ $T_{amb} = +25^{\circ}C$ $C_L = 50pF$ $R_L = 500\Omega$			$V_{CC} = +5.0V \pm 10\%$ $T_{amb} = 0^{\circ}C \text{ to } +70^{\circ}C$ $C_L = 50pF$ $R_L = 500\Omega$		$V_{CC} = +5.0V \pm 10\%$ $T_{amb} = -40^{\circ}C \text{ to } +85^{\circ}C$ $C_L = 50pF$ $R_L = 500\Omega$		
			MIN	TYP	MAX	MIN	MAX	MIN		MAX
f_{MAX}	Maximum clock frequency	Waveform 1	85	100		80		80		MHz
t_{PLH} t_{PHL}	Propagation delay CP to Qn or $\bar{Q}n$	Waveform 1	2.0 2.0	5.0 5.0	6.5 6.5	2.0 2.0	7.5 7.5	2.0 2.0	7.5 7.5	ns
t_{PLH} t_{PHL}	Propagation delay $\bar{S}Dn, \bar{R}D$ to Qn or $\bar{Q}n$	Waveform 2,3	2.0 2.0	4.5 4.5	6.5 6.5	2.0 2.0	7.5 7.5	1.5 1.5	7.5 7.5	ns

AC SETUP REQUIREMENTS

SYMBOL	PARAMETER	TEST CONDITION	LIMITS						UNIT	
			$V_{CC} = +5.0V$ $T_{amb} = +25^{\circ}C$ $C_L = 50pF$ $R_L = 500\Omega$			$V_{CC} = +5.0V \pm 10\%$ $T_{amb} = 0^{\circ}C \text{ to } +70^{\circ}C$ $C_L = 50pF$ $R_L = 500\Omega$		$V_{CC} = +5.0V \pm 10\%$ $T_{amb} = -40^{\circ}C \text{ to } +85^{\circ}C$ $C_L = 50pF$ $R_L = 500\Omega$		
			MIN	TYP	MAX	MIN	MAX	MIN		MAX
$t_{S(H)}$ $t_{S(L)}$	Setup time, High or Low Jn, Kn to $\bar{C}P$	Waveform 1	4.0 3.5			5.0 4.0			5.0 4.0	ns
$t_{H(H)}$ $t_{H(L)}$	Hold time, High or Low Jn, Kn to $\bar{C}P$	Waveform 1	0.0 0.0			0.0 0.0			0.0 0.0	ns
$t_{W(H)}$ $t_{W(L)}$	$\bar{C}P$ Pulse width High or Low	Waveform 1	4.5 4.5			5.0 5.0			5.0 5.0	ns
$t_{W(L)}$	$\bar{S}Dn, \bar{R}D$ Pulse width Low	Waveform 2,3	4.5			5.0			5.0	ns
t_{REC}	Recovery time $\bar{S}Dn, \bar{R}D$ to $\bar{C}P$	Waveform 2,3	4.5			5.0			5.0	ns

AC WAVEFORMS

For all waveforms, $V_M = 1.5V$.

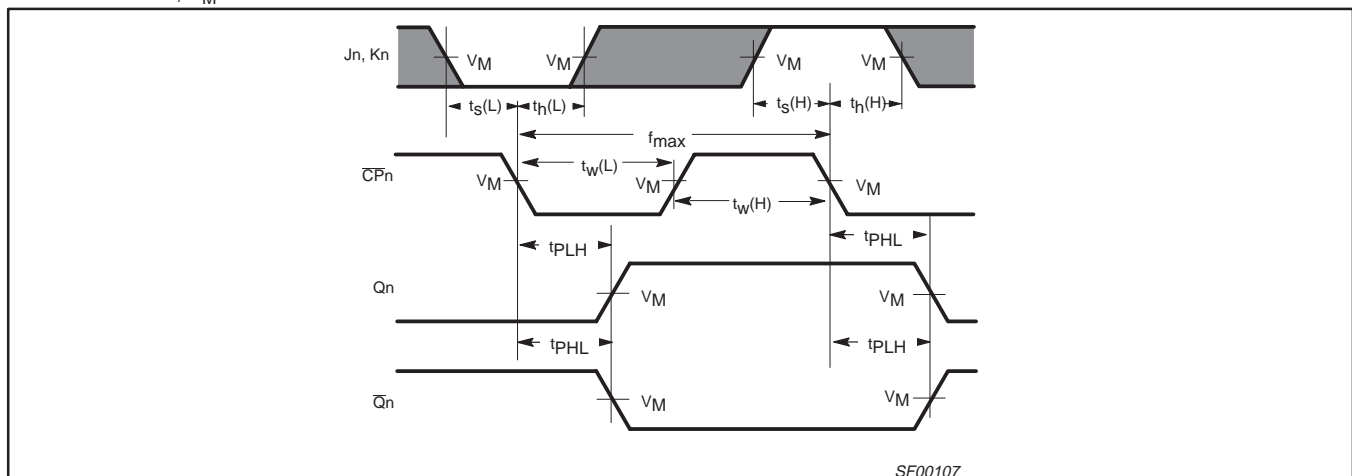

The shaded areas indicate when the input is permitted to change for predictable output performance.

Waveform 1. Propagation Delay for Data to Output, Data Setup Time and Hold Times, and Clock Pulse Width

Dual J-K negative edge-triggered flip-flop

74F112

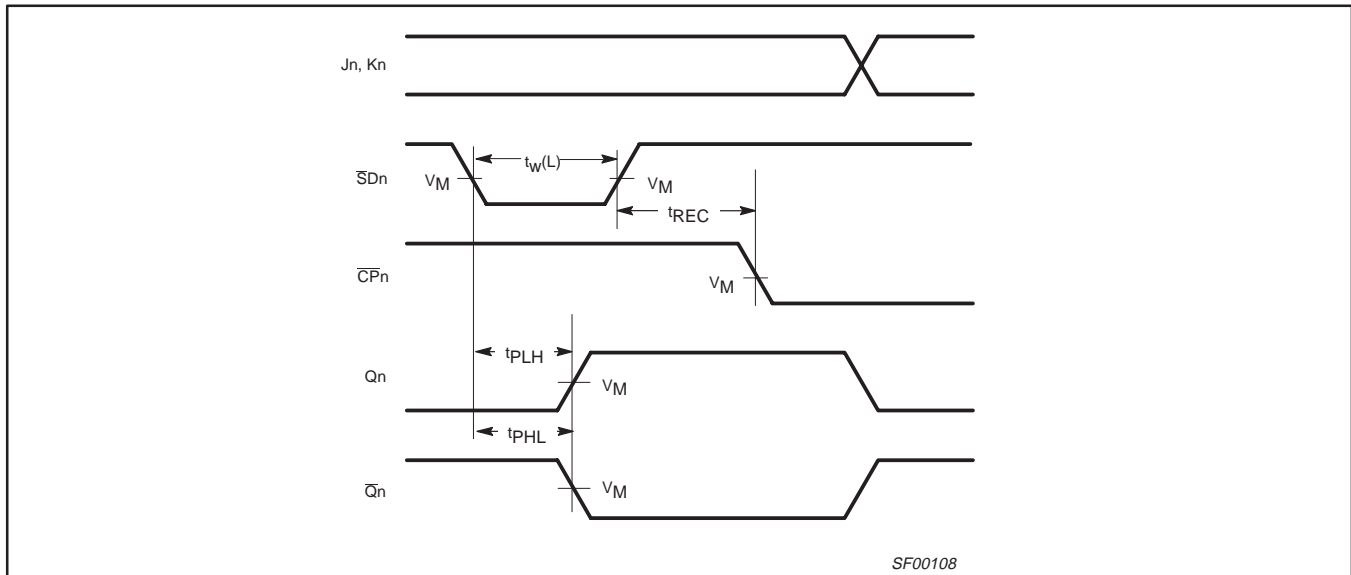

Waveform 2. Propagation Delay for Set to Output, Set Pulse Width, and Recovery Time for Set to Clock

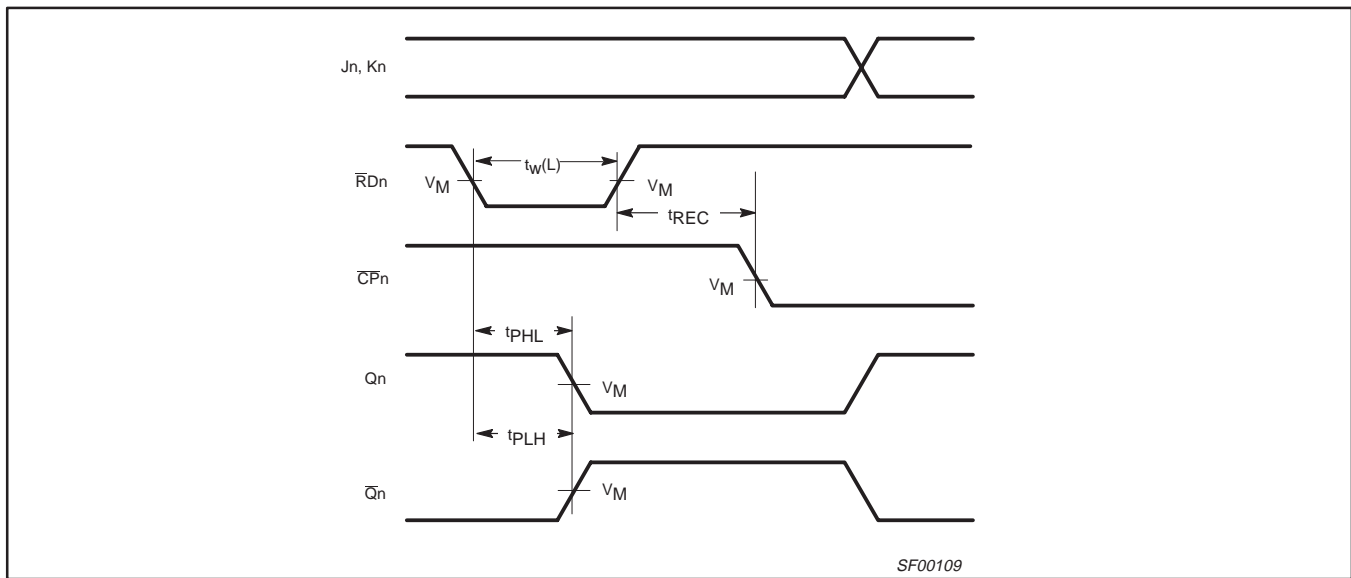

Waveform 3. Propagation Delay for Reset to Output, Reset Pulse Width, and Recovery Time for Reset to Clock

Dual J-K negative edge-triggered flip-flop

74F112

TEST CIRCUIT AND WAVEFORMS

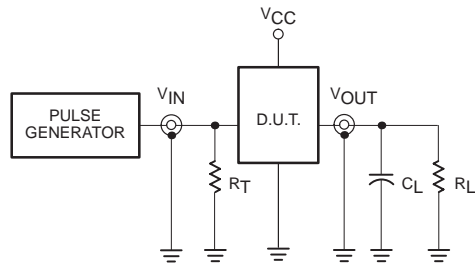

Test Circuit for Totem-Pole Outputs

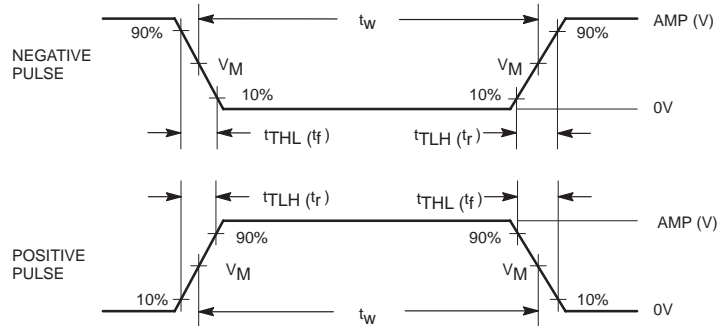

Input Pulse Definition

DEFINITIONS:

- R_L = Load resistor; see AC ELECTRICAL CHARACTERISTICS for value.
- C_L = Load capacitance includes jig and probe capacitance; see AC ELECTRICAL CHARACTERISTICS for value.
- R_T = Termination resistance should be equal to Z_{OUT} of pulse generators.

family	INPUT PULSE REQUIREMENTS					
	amplitude	V_M	rep. rate	t_w	t_{TLH}	t_{THL}
74F	3.0V	1.5V	1MHz	500ns	2.5ns	2.5ns

SF00006

Dual J-K negative edge-triggered flip-flop

74F112

DIP16: plastic dual in-line package; 16 leads (300 mil)

SOT38-4

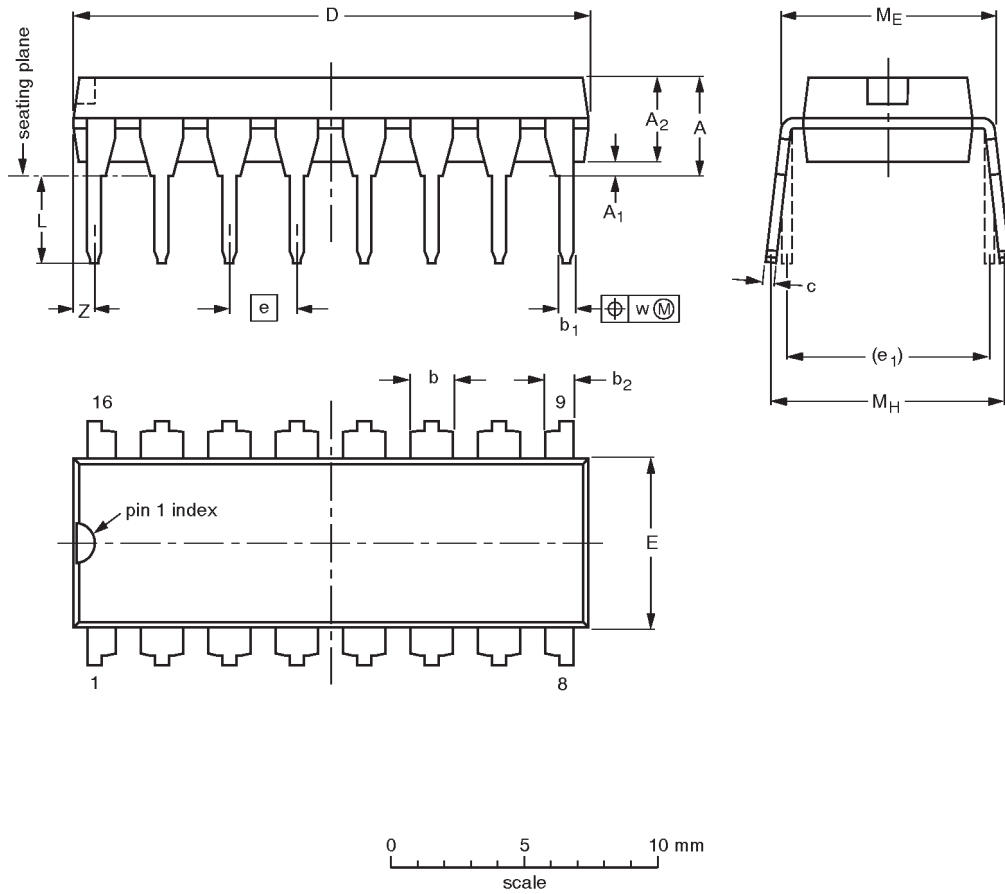

DIMENSIONS (inch dimensions are derived from the original mm dimensions)

UNIT	A max.	A ₁ min.	A ₂ max.	b	b ₁	b ₂	c	D ⁽¹⁾	E ⁽¹⁾	e	e ₁	L	M _E	M _H	w	Z ⁽¹⁾ max.
mm	4.2	0.51	3.2	1.73 1.30	0.53 0.38	1.25 0.85	0.36 0.23	19.50 18.55	6.48 6.20	2.54	7.62	3.60 3.05	8.25 7.80	10.0 8.3	0.254	0.76
inches	0.17	0.020	0.13	0.068 0.051	0.021 0.015	0.049 0.033	0.014 0.009	0.77 0.73	0.26 0.24	0.10	0.30	0.14 0.12	0.32 0.31	0.39 0.33	0.01	0.030

Note

1. Plastic or metal protrusions of 0.25 mm maximum per side are not included.

OUTLINE VERSION	REFERENCES				EUROPEAN PROJECTION	ISSUE DATE
	IEC	JEDEC	EIAJ			
SOT38-4						92-11-17 95-01-14

Dual J-K negative edge-triggered flip-flop

74F112

SO16: plastic small outline package; 16 leads; body width 3.9 mm

SOT109-1

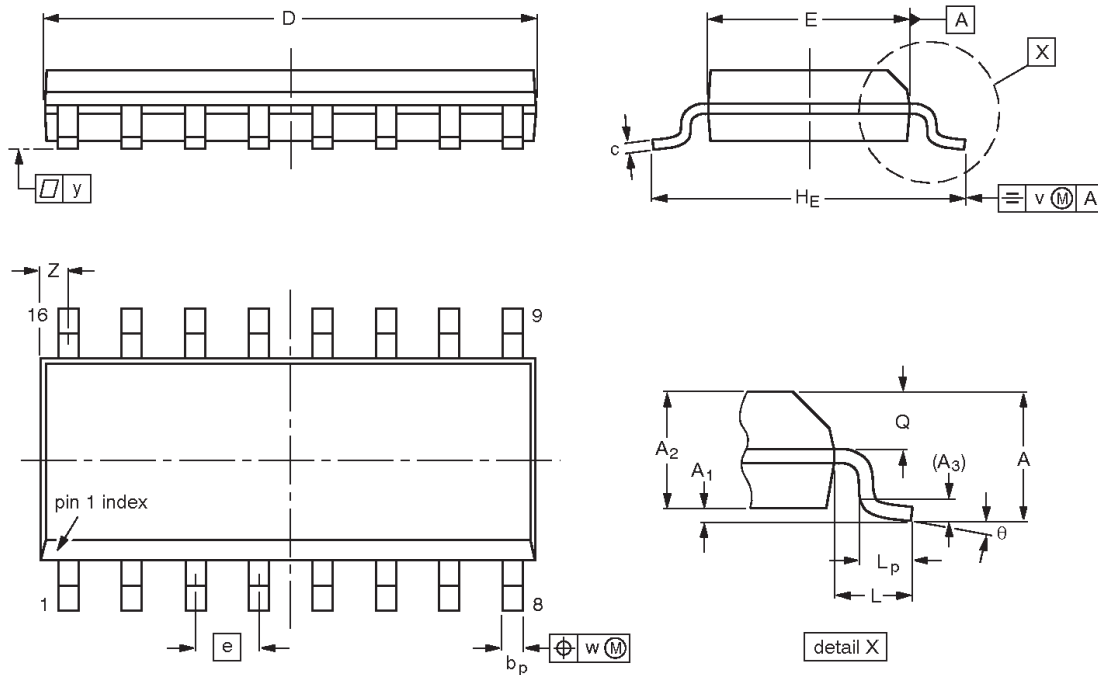

DIMENSIONS (inch dimensions are derived from the original mm dimensions)

UNIT	A max.	A ₁	A ₂	A ₃	b _p	c	D ⁽¹⁾	E ⁽¹⁾	e	H _E	L	L _p	Q	v	w	y	Z ⁽¹⁾	θ
mm	1.75 0.10	0.25 1.25	1.45 1.25	0.25	0.49 0.36	0.25 0.19	10.0 9.8	4.0 3.8	1.27	6.2 5.8	1.05	1.0 0.4	0.7 0.6	0.25	0.25	0.1	0.7 0.3	8° 0°
inches	0.069 0.004	0.010 0.049	0.057 0.049	0.01	0.019 0.014	0.0100 0.0075	0.39 0.38	0.16 0.15	0.050	0.244 0.228	0.041	0.039 0.016	0.028 0.020	0.01	0.01	0.004	0.028 0.012	

Note

1. Plastic or metal protrusions of 0.15 mm maximum per side are not included.

OUTLINE VERSION	REFERENCES				EUROPEAN PROJECTION	ISSUE DATE
	IEC	JEDEC	EIAJ			
SOT109-1	076E07S	MS-012AC				95-01-23 97-05-22

Dual J-K negative edge-triggered flip-flop

74F112

Data sheet status

Data sheet status	Product status	Definition [1]
Objective specification	Development	This data sheet contains the design target or goal specifications for product development. Specification may change in any manner without notice.
Preliminary specification	Qualification	This data sheet contains preliminary data, and supplementary data will be published at a later date. Philips Semiconductors reserves the right to make changes at any time without notice in order to improve design and supply the best possible product.
Product specification	Production	This data sheet contains final specifications. Philips Semiconductors reserves the right to make changes at any time without notice in order to improve design and supply the best possible product.

[1] Please consult the most recently issued datasheet before initiating or completing a design.

Definitions

Short-form specification — The data in a short-form specification is extracted from a full data sheet with the same type number and title. For detailed information see the relevant data sheet or data handbook.

Limiting values definition — Limiting values given are in accordance with the Absolute Maximum Rating System (IEC 134). Stress above one or more of the limiting values may cause permanent damage to the device. These are stress ratings only and operation of the device at these or at any other conditions above those given in the Characteristics sections of the specification is not implied. Exposure to limiting values for extended periods may affect device reliability.

Application information — Applications that are described herein for any of these products are for illustrative purposes only. Philips Semiconductors make no representation or warranty that such applications will be suitable for the specified use without further testing or modification.

Disclaimers

Life support — These products are not designed for use in life support appliances, devices or systems where malfunction of these products can reasonably be expected to result in personal injury. Philips Semiconductors customers using or selling these products for use in such applications do so at their own risk and agree to fully indemnify Philips Semiconductors for any damages resulting from such application.

Right to make changes — Philips Semiconductors reserves the right to make changes, without notice, in the products, including circuits, standard cells, and/or software, described or contained herein in order to improve design and/or performance. Philips Semiconductors assumes no responsibility or liability for the use of any of these products, conveys no license or title under any patent, copyright, or mask work right to these products, and makes no representations or warranties that these products are free from patent, copyright, or mask work right infringement, unless otherwise specified.

Philips Semiconductors
811 East Arques Avenue
P.O. Box 3409
Sunnyvale, California 94088-3409
Telephone 800-234-7381

© Copyright Philips Electronics North America Corporation 1998
All rights reserved. Printed in U.S.A.

print code

Date of release: 10-98

Document order number:

9397-750-05071

Let's make things better.